

PRODUCT INTRODUCTION

CONTENTS

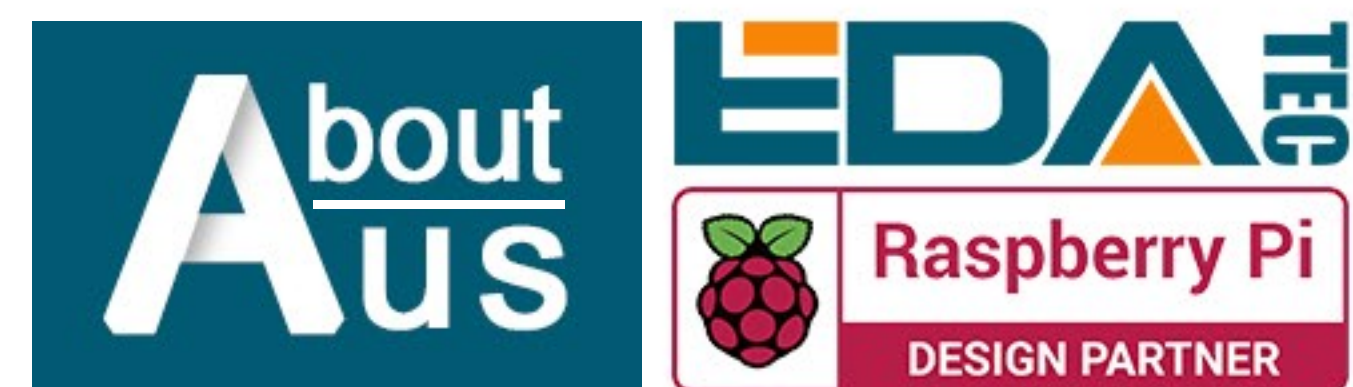

03	About us
04	ED-IPC2010
05	REIMEI1
06	CM4 AI Camera
07	CM4 Sensing
10	CM4 Nano
13	CM4 Industrial
16	CM4 Media
19	ED-IPC2120
22	ED-MVB2010
25	IoT Gateway
28	ED-IoTHotspot-M1
30	ED-IoTHotspot-Pi02
32	ED-IoTHotspot-Pi4
34	CM4 IO Computer
36	CM4 IO Smart Case
37	ED-GW1302S/1303S LoRaWAN Gateway Module
38	CM4 Cooler
39	CM4 Mass Programming Service
40	Contact Information



EDA Technology Co., LTD is located in Shanghai, it is one of Raspberry Pi's Global Design Partners.

Our vision is to offer the hardware solutions for IoT, Industrial Control, Automation, Green Energy & Artificial Intelligence based on Raspberry Pi technology platform.

We provide the standard hardware solutions, custom design & manufacturing services that accelerate the electronic product development and time to market.

We have R&D centers in Shanghai, Wuhan & Shenzhen, production facility in Dongguan, China, and sales representatives in China and United States.

ED-IPC2010

ED-IPC2010 is a computer based on Raspberry Pi CM4 for industrial application scenarios.

ED-IPC2010 is compatible with the hardware and software of Raspberry Pi, and its overall size is slightly larger than that of Pi4. It has made a lot of enhancements to industrial applications, adding an aluminum alloy shell outside to greatly improve the heat dissipation performance, and adding additional encryption chips and RTC and other common modules on the board. Multiple functions enable the IPC2010 to be applied in multimedia entertainment, AI, smart meters, panoramic display, smart living and other applications.



REIMEI1

REIMEI1 is a compact SBC (Single Board Computer) with low cost and high performance. Suitable for a wide range of fields such as IOT, industrial applications and creators.

Highlight

- ◆ 14nm, 4-core, Cortex-A55 SoC, up to 2.0GHz
- ◆ GPU, support Open GL ES
- ◆ VPU, support H.264, H.265 codec, H.265 decode 4Kp75,H.265 encode up to 2Kp60
- ◆ eMMC + micro SD dual storage, dual boot, SD card priority high
- ◆ Onboard dual-band WiFi + BT 5.0, external antennas.
- ◆ 1x USB 3.0, 1x USB 2.0, 1x 10/100M Ethernet.
- ◆ 40-Pin GPIO, compatible with Raspberry Pi HAT
- ◆ Certified by FCC, CE
- ◆ Compatible with Raspberry Pi OS,Linux Kernel 5.4, bullseye, 64-bit, Support Lite, Desktop, Device Tree Overlay, GPU hard decoding, VPU hard codec.

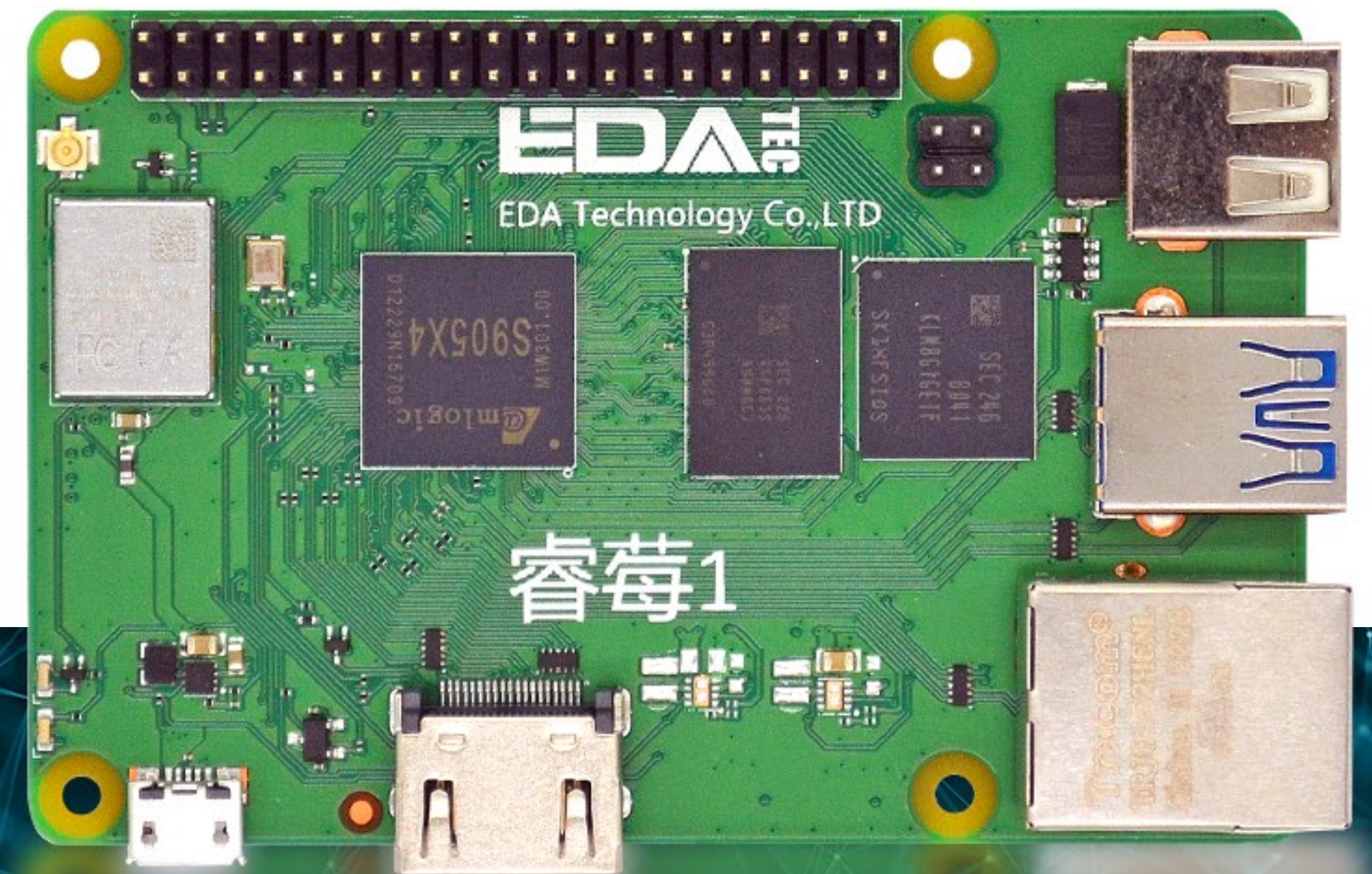

CM4 AI Camera

ED-AIC2000 is a highly integrated Industrial AI Camera equipped with a fixed or liquid lens, LED illumination, Industrial grade image sensor and a Raspberry Pi Computer Module 4 (CM4). Equipped with varifocal lens and LED illumination, ED-AIC2000 reduces installation and maintenance effort significantly.

Highlight

- ◆ **Designed based on Raspberry Pi Computer Module 4**
1GB/2GB/4GB/8GB DDR and 8GB/16GB/32GB eMMC optional
2MP Global Shutter, 5MP Rolling Shutter CMOS Image Sensors optional
fixed or liquid Lens optional
Built-in LED illumination ; support external light sources
1x 10/100/1000M Ethernet with M12 Connector
1x PWR / IO M12 Connector with 4 isolated GPIO and 1x RS232
OpenCV 4.5.4, Python 3.7 and QT pre-installed
Support YOLO V5 and V8, 3rd Machine Vision Libraries like Halcon, AVS and etc.
- ◆ **Alumiumal case by CNC IP67 Water proof**
- ◆ **Shock Resistance** : EN 60068-2-27
- ◆ **Vibration Resistance**: EN 60068-2-6



CM4 Sensing

CM4 Sensing is an industrial computer, specially designed for IoT, Data Acquisition and Smart Agriculture application, the solution is based on Raspberry Pi Compute Module 4 (CM4 for short). It provides 4 channels of RS485, 1 channel of RS232 and 1 channel of CAN interface, the system can access the cloud by 4G, WiFi or Giga-bit ethernet, another special design is the storage, when eMMC on CM4 stores the code, SD card can store the user data.

Highlight

- ◆ Powered by **Raspberry Pi CM4** with mature software ecosystem
- ◆ Dual Storage with eMMC and SD Card for data storage
- ◆ Full Coverage Network with Gig-Ethernet, Dual-band WiFi and 4G LTE
- ◆ Rich Industrial Interface with RS232, CAN and up to 4 RS485
- ◆ Small, Beautiful with excellent cooling system, Support DIN-rail mounting



Sensing IoT World by Raspberry Pi Powered Industrial Computer

<https://www.edatec.cn/en/elpc/cm4-sen.html>

SPECIFICATIONS

Category	Feature
Processor	Broadcom BCM2711 quad-core Cortex-A72 (ARM v8) 64-bit SoC @ 1.5GHz H.265 (HEVC) (up to 4Kp60 decode), H.264 (up to 1080p60 decode, 1080p30 encode) OpenGL ES 3.1, Vulkan 1.0
RAM	1GB / 2GB / 4GB / 8GB LPDDR4-3200 SDRAM
Storage	Onboard 8GB / 16GB / 32GB eMMC for system boot 1x microSD Card for Data Storage, can work with eMMC together at the same time
Display	1x standard HDMI Out (Type A) 1x FPC HDMI Touch Display 1x FPC DSI Touch Display
Wired Interface	1x Gig-Ethernet (10/100/1000M) 2x USB 2.0 Type-A 1x USB micro-B for eMMC Flashing (Inside the case)
Wireless	Optional 2.4 GHz, 5.0 GHz IEEE 802.11 b/g/n/ac wireless and Bluetooth 5.0, BLE with external antenna Optional 4G LTE with optional GPS support, 1x Nano-SIM card slot, external antenna
Industrial Interface	4x RS485, 3-pin Terminal Block 1x RS232, 3-pin Terminal Block 1x CAN, 3-pin Terminal Block 1x RTC with CR1220 backup 1x Buzzer
Expansion Interface	1x mini-PCIe slot with 1-lane PCIe and 1x USB 2.0, Support 4G Module 1x 5V@1A DC Power output, 2-pin WTB connector, Could supply Raspberry Pi official 7" Touch Display
Power In	8 ~ 28V DC DC Jack or optional 2-pin Terminal Block
Indicator	1x Power Indicator with Red LED 1x Status Indicator with Green LED 1x 4G network indicator with Blue LED (Inside the case)
Operating Temperature Range	-25 ~ 60°C
Operating Humidity	10% - 60%
Case	Metal Case with a whole side Aluminum Alloy Heat Sink, 2 Antenna Holes
Dimension	103(L) x 73(W) x 32(H) mm
Mounting Options	DIN-mount with DIN kit installed Wall-mount
OS	Pre-installed with 32-bit Raspberry Pi OS with Desktop in eMMC Compatible with Origin Raspberry Pi OS, support 32-bit and 64-bit OS, support Lite and Desktop versions Support BSP online install / upgrade with APT tool

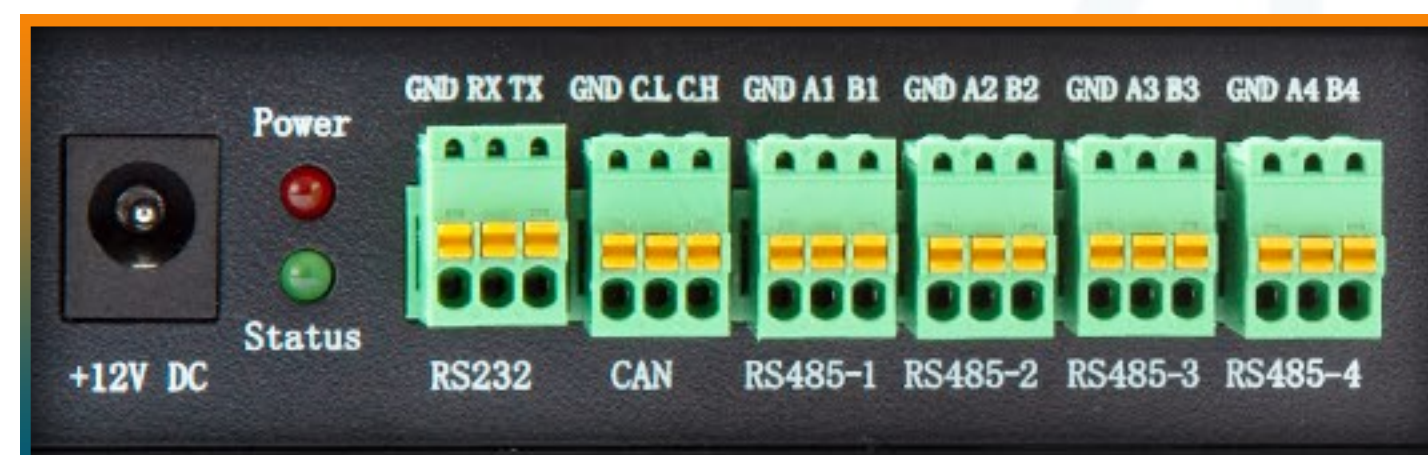

Order Information

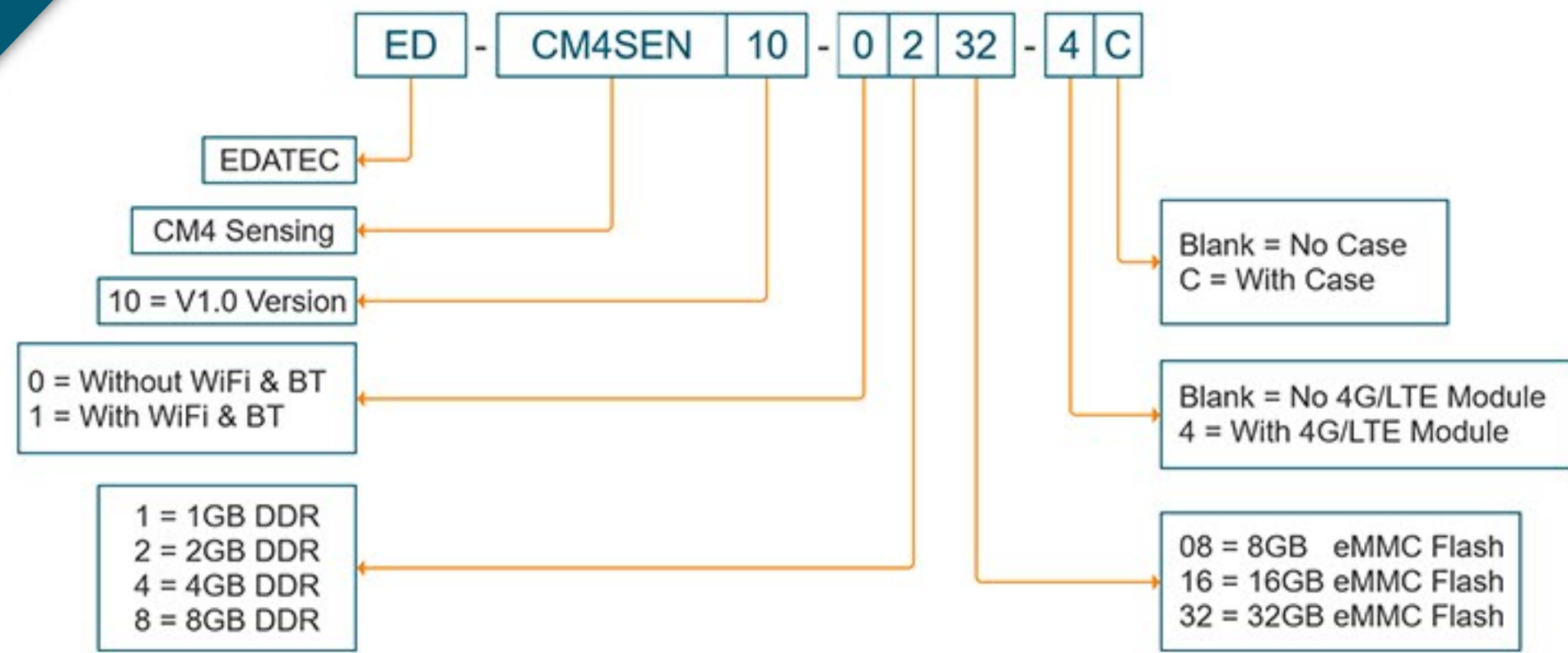

Interface Diagram

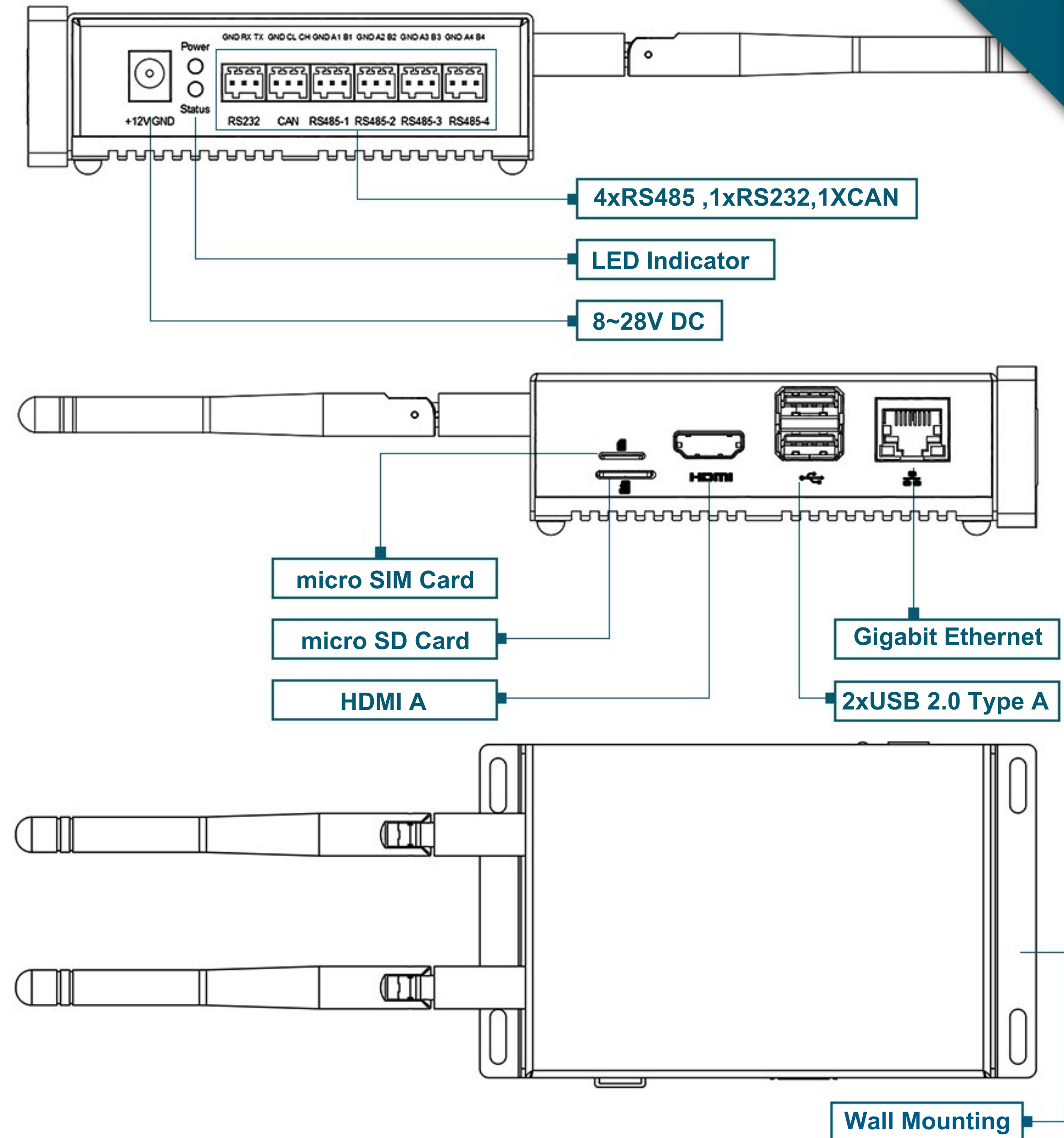

Dimension

Unit:mm

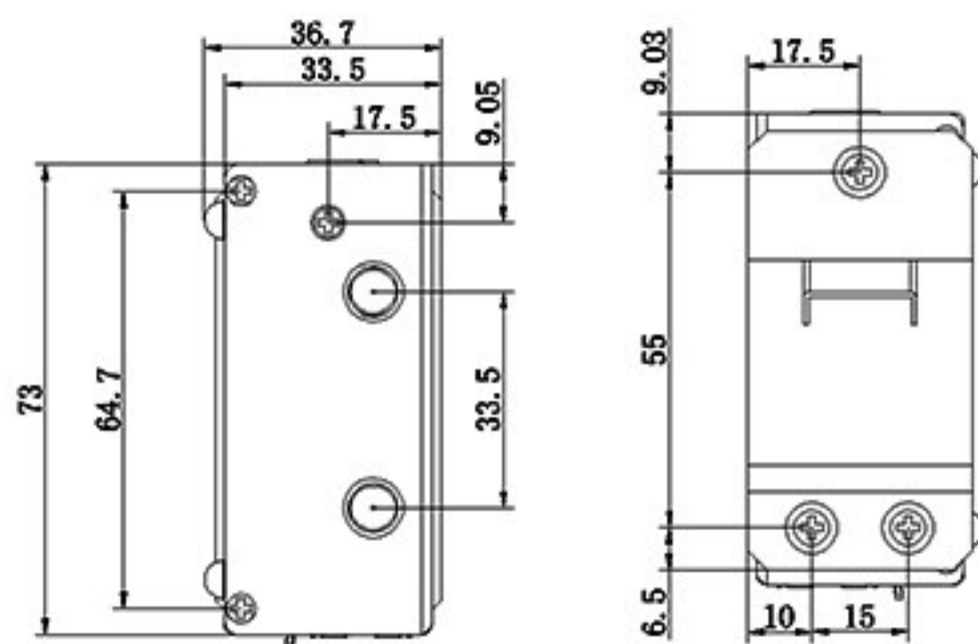
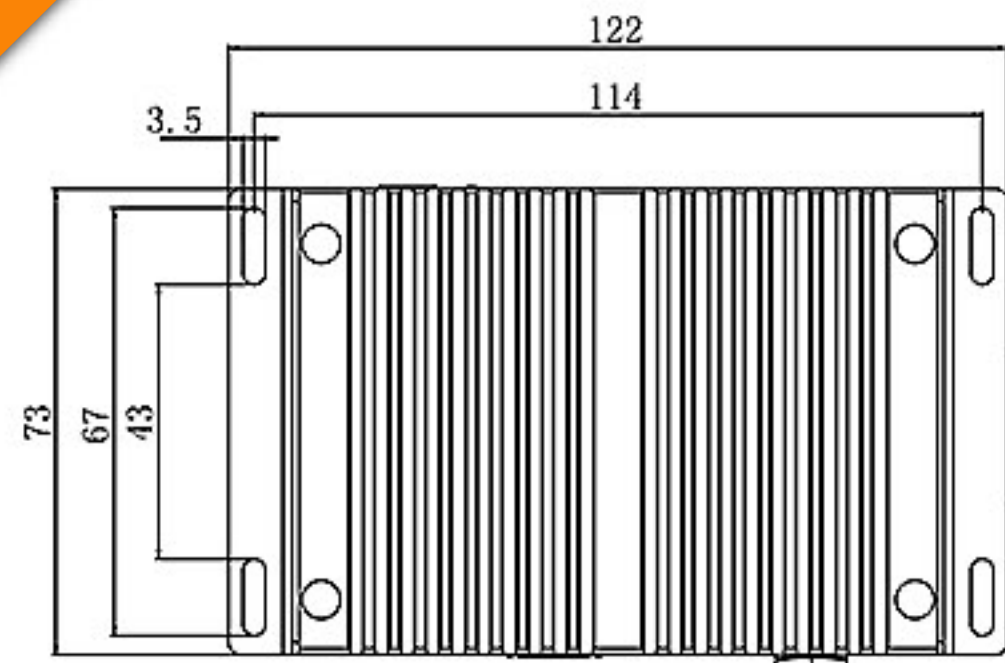

CM4 NANO

CM4 NANO is an Industrial Computer based on Raspberry Pi Compute Module 4, which provides full 40pins expansion capability like standard Raspberry Pi 4, but specially consider about the requirement of system reliability, the system can work at $-25^{\circ}\sim 60^{\circ}$ reliably thanks to CNC cut aluminum heatsink at the bottom case. Same as CM4 Sensing, when OS is stored on eMMC, the user data can be stored on SD card which provides both low cost and reliable storage solution.

Highlight

- ◆ Powered by **Raspberry Pi CM4** with mature software ecosystem
- ◆ Dual Storage with eMMC and SD Card for data storage
- ◆ Rich Interface with 1x Standard HDMI, 2x USB 3.0, 1x USB 2.0 and 40-PIN GPIO Expansion Interface
- ◆ Industrial Application Enhanced with 8 ~ 18V DC Input, External WiFi Antenna, RTC and Buzzer
- ◆ Compact, full meta case with excellent cooling system, Support DIN-rail mounting



The Industrial Raspberry Pi that You Expect

<https://www.edatec.cn/en/elpc/cm4-nano.html>

SPECIFICATIONS



Category	Feature
Processor	Broadcom BCM2711 quad-core Cortex-A72 (ARM v8) 64-bit SoC @ 1.5GHz H.265 (HEVC) (up to 4Kp60 decode), H.264 (up to 1080p60 decode, 1080p30 encode) OpenGL ES 3.1, Vulkan 1.0
RAM	1GB / 2GB / 4GB / 8GB LPDDR4-3200 SDRAM
Storage	Onboard 8GB / 16GB / 32GB eMMC for system boot 1x microSD Card for Data Storage, can work with eMMC together at the same time
Display	1x standard HDMI Out (Type A) 1x FPC HDMI Touch Display 1x FPC DSI Touch Display
Wired Interface	1x Gig-Ethernet (10/100/1000M), Support PoE (with Raspberry Pi PoE HAT) 2x USB 3.0 Type-A 1x USB 2.0 Type-A 1x USB 3.0 Type-C (Inside the case)
Wireless	Optional 2.4 GHz, 5.0 GHz IEEE 802.11 b/g/n/ac wireless and Bluetooth 5.0, BLE with external antenna
Industrial Interface	1x RTC with CR1220 backup 1x Buzzer
Expansion Interface	1x standard Raspberry Pi 40-PIN GPIO 1x 5V@1A DC Power output, 2-pin WTB connector, Could supply Raspberry Pi official 7" Touch Display 1x System Reset, 3-pin DIP connector 1x Boot Configuration, 2-pin DIP connector
Power In	8 ~ 18V DC DC Jack
Indicator	1x Power Indicator with Red LED 1x Status Indicator with Green LED
Operating Temperature Range	-25 ~ 60°C
Operating Humidity	10% - 60%
Case	Metal Case with a whole side Aluminum Alloy Heat Sink, 1 Antenna Holes
Dimension	103(L) x 62(W) x 22(H) mm
Mounting Options	DIN-mount Wall-mount
OS	Pre-installed with 32-bit Raspberry Pi OS with Desktop in eMMC Compatible with Origin Raspberry Pi OS, support 32-bit and 64-bit OS, support Lite and Desktop versions Support BSP online install / upgrade with APT tool

Interface Diagram

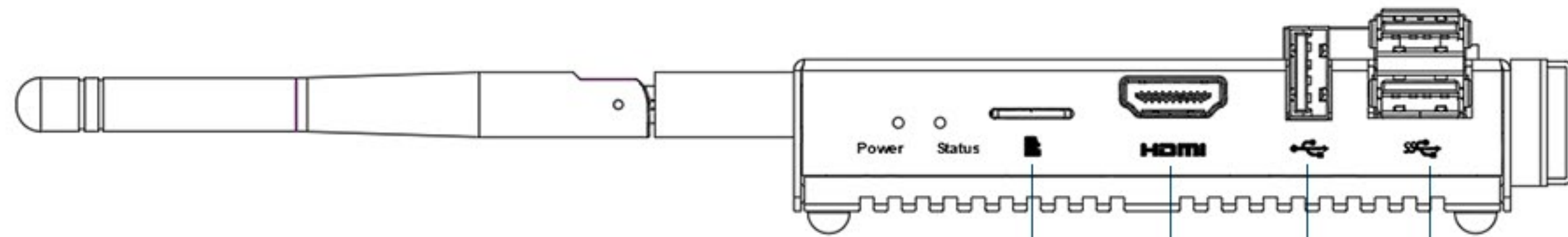

Micro SD for Data Storage

Standard HDMI

1xUSB 2.0 Type A

2xUSB 3.0 Type A

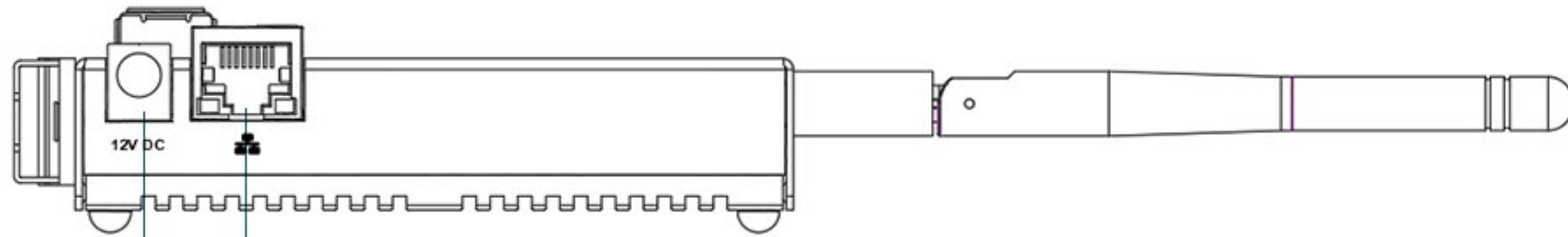

Gigabit Ethernet

8 ~ 18V DC IN

Wall Mounting

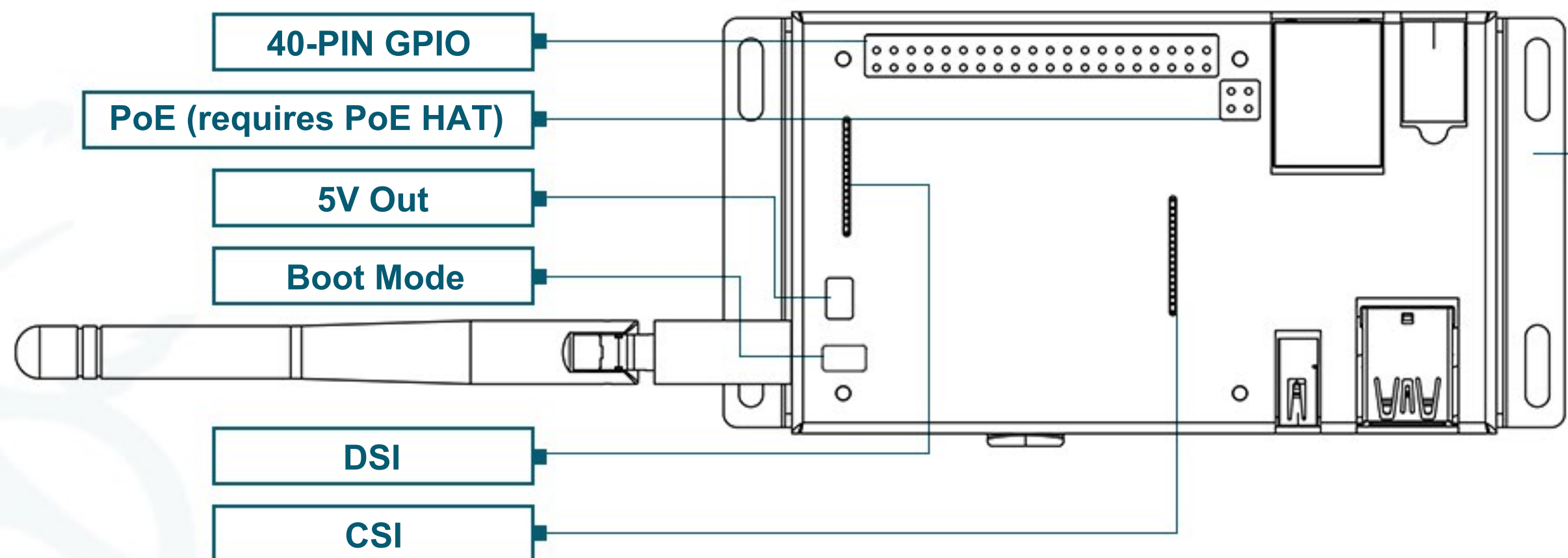

40-PIN GPIO

PoE (requires PoE HAT)

5V Out

Boot Mode

DSI

CSI

Order Information

ED - CM4NANO 10 - 0 2 32 - C

EDATEC

CM4 Nano

10 = V1.0 Version

0 = Without WiFi & BT
1 = With WiFi & BT

1 = 1GB DDR
2 = 2GB DDR
4 = 4GB DDR
8 = 8GB DDR

Blank = No Case
C = With Case

08 = 8GB eMMC Flash
16 = 16GB eMMC Flash
32 = 32GB eMMC Flash

Dimension

Unit:mm

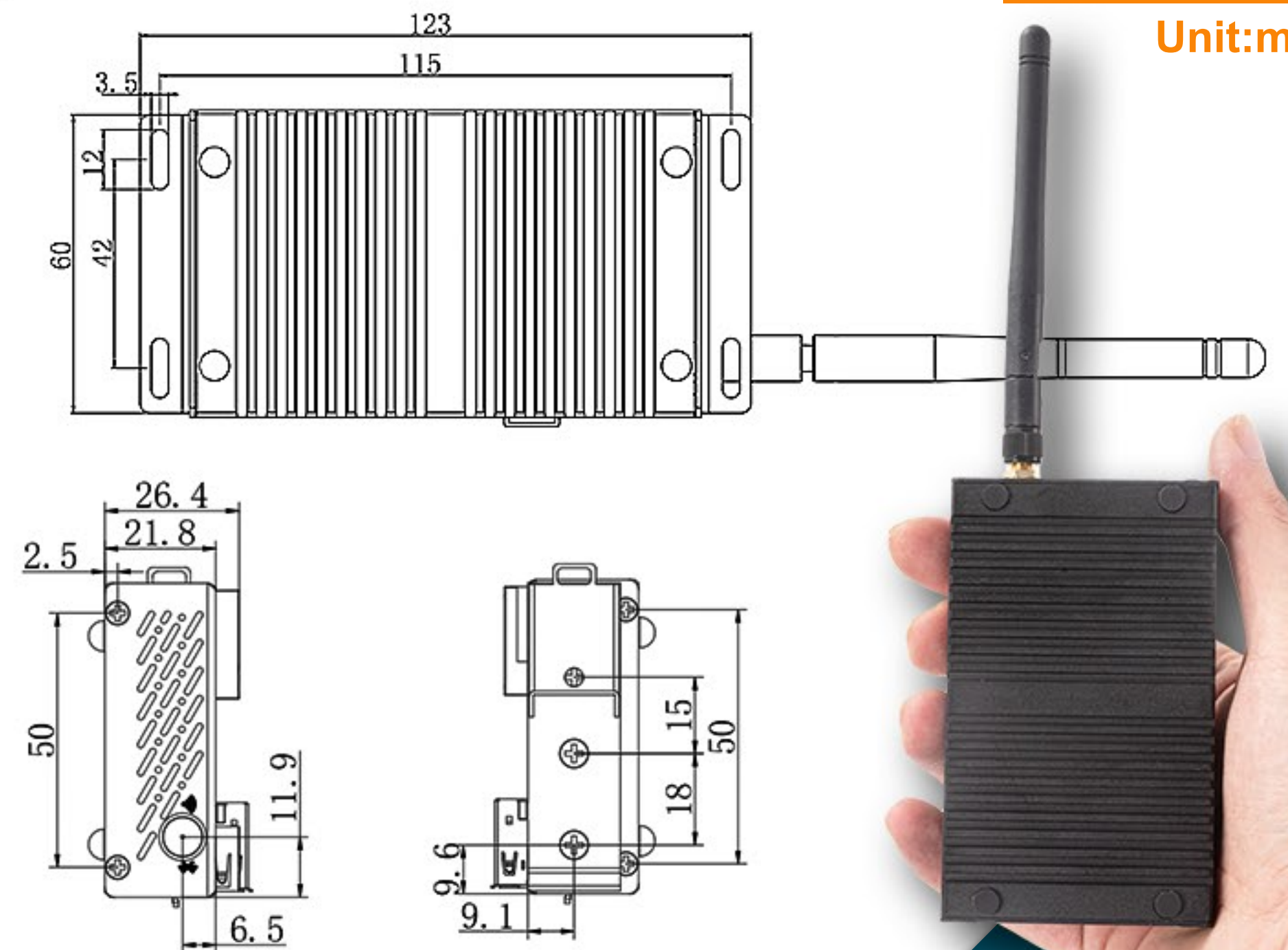

CM4 Industrial

CM4 Industrial is a computer specially designed for Industrial Control application based on Raspberry Pi Compute Module 4. It provides all of popular industrial interfaces or features, such as dual ethernets, RS485, RS232, ADC, Isolated GPIO, Relay, RTC, Buzzer, the system can access the cloud by 4G, WiFi or ethernet.

Highlight

- ◆ Powerful performance with Quad-core CPU, up to 8GB RAM and up to 32GB eMMC
- ◆ Dual LAN support with 1x Gig-Ethernet and 1x Fast Ethernet
- ◆ Support a wide range of wireless including Dual-band WiFi, Bluetooth and 4G LTE with Optional GPS
- ◆ Rich Industrial Interface with 8 ~ 36V DC Power Input, RTC, SPI Flash, 1x RS232, 2x RS485, 3x ADC Channels, 2x isolated DI and 1x SPDT Relay
- ◆ Full meta case with Fan support, Support DIN-rail mounting



Industrial Computer for IoT, Industrial Control and Automation

<https://www.edatec.cn/en/elpc/cm4-ind.html>

SPECIFICATIONS

Category	Feature
Processor	Broadcom BCM2711 quad-core Cortex-A72 (ARM v8) 64-bit SoC @ 1.5GHz H.265 (HEVC) (up to 4Kp60 decode), H.264 (up to 1080p60 decode, 1080p30 encode) OpenGL ES 3.1, Vulkan 1.0
RAM	1GB / 2GB / 4GB / 8GB LPDDR4-3200 SDRAM
Storage	Onboard 0GB / 8GB / 16GB / 32GB eMMC 1x microSD Card Slot for system boot when choosing 0GB(CM4 Lite) eMMC Onboard 32Mbits SPI Flash
Display	1x standard HDMI Out (Type A) 1x FPC HDMI Touch Display 1x FPC DSI Touch Display
Camera	1x FPC CSI, Support Raspberry Pi Official 5M & 8M Cameras
Wired Interface	1x Gig-Ethernet (10/100/1000M), Support PoE (with Raspberry Pi PoE HAT) 1x Fast-Ethernet (10/100M) 2x USB 2.0 Type-A 1x USB micro-B for eMMC Flashing (Inside the case)
Wireless	Optional 2.4 GHz, 5.0 GHz IEEE 802.11 b/g/n/ac wireless and Bluetooth 5.0, BLE with external antenna Optional 4G LTE with optional GPS support, 1x Standard-SIM card slot, external antenna
Industrial Interface	2x RS485, 6-pin Terminal Block 1x RS232, 3-pin Terminal Block 3x 12-bits ADC Channels, 4-pin Terminal Block 2x isolated DI, Support Dry / Wet Contact 1x DPDT Relay, 6-pin Terminal Block 1x RTC with CR1220 backup 1x adjustable speed fan control, 3-pin wafer connector 1x Buzzer
Expansion Interface	1x mini-PCIe slot with 1-lane PCIe and 1x USB 2.0, Support 4G Module 1x standard Raspberry Pi 40-PIN GPIO 1x Serial(TTL), 4-pin DIP connector 2x USB 2.0, 4-pin DIP connector 1x non-isolated IO, 2-pin DIP connector
Power In	8 ~ 36V DC DC Jack or optional 2-pin Terminal Block
Indicator	1x Power Indicator with Red LED 1x Status Indicator with Green LED 1x 4G network indicator with Blue LED (Inside the case)
Buttons	1x System Reset Button 1x User Button
Operating Temperature Range	-25 ~ 50°C
Operating Humidity	10% - 60%
Case	Metal Case, 2 Antenna Holes
Dimension	147(L) x 119(W) x 28(H) mm
Mounting Options	DIN-mount Wall-mount
OS	Pre-installed with 32-bit Raspberry Pi OS with Desktop in eMMC(if choosing eMMC variants) Compatible with Origin Raspberry Pi OS, support 32-bit and 64-bit OS, support Lite and Desktop versions Support BSP online install / upgrade with APT tool

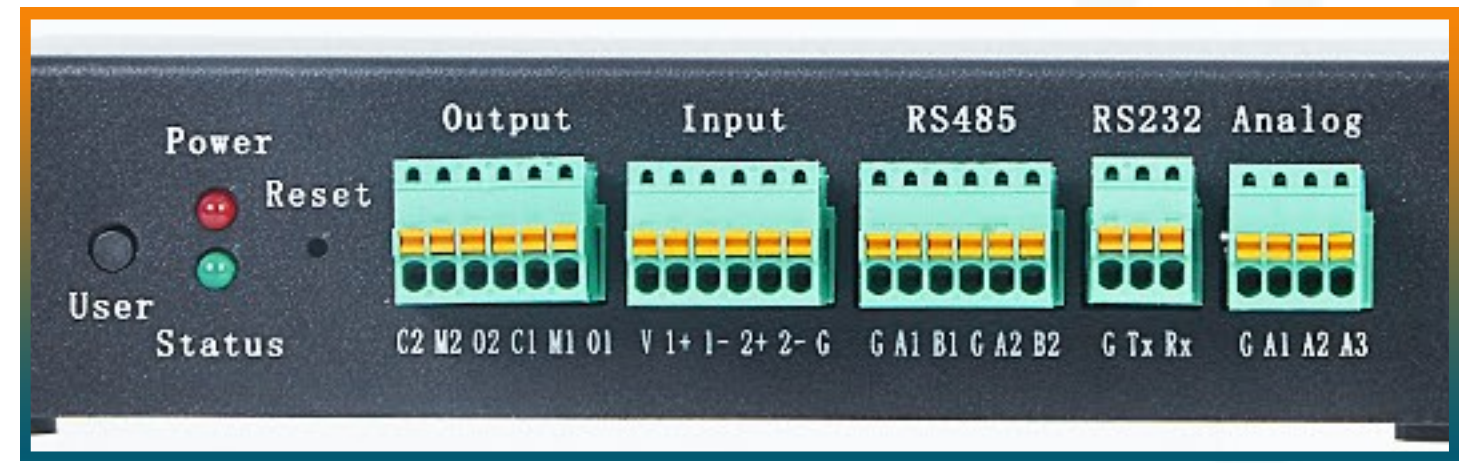

Order Information

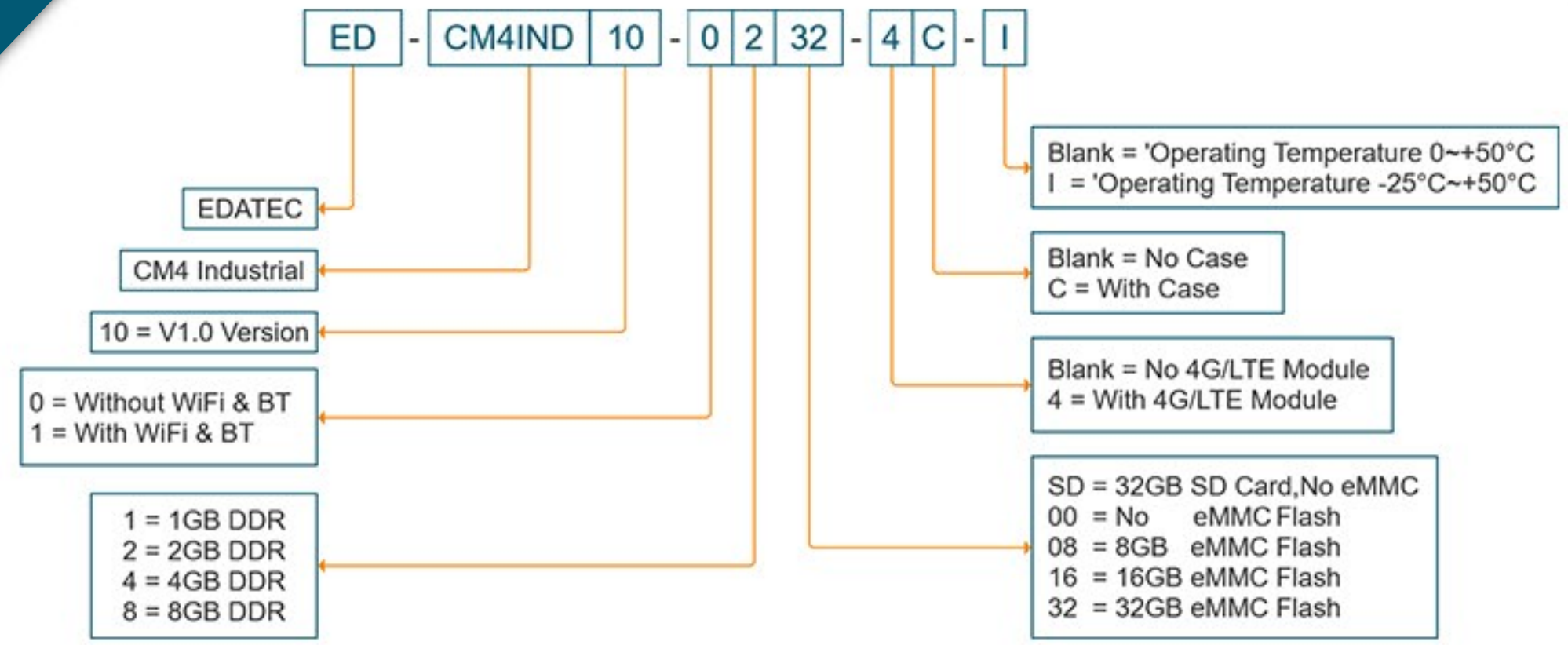

Interface Diagram

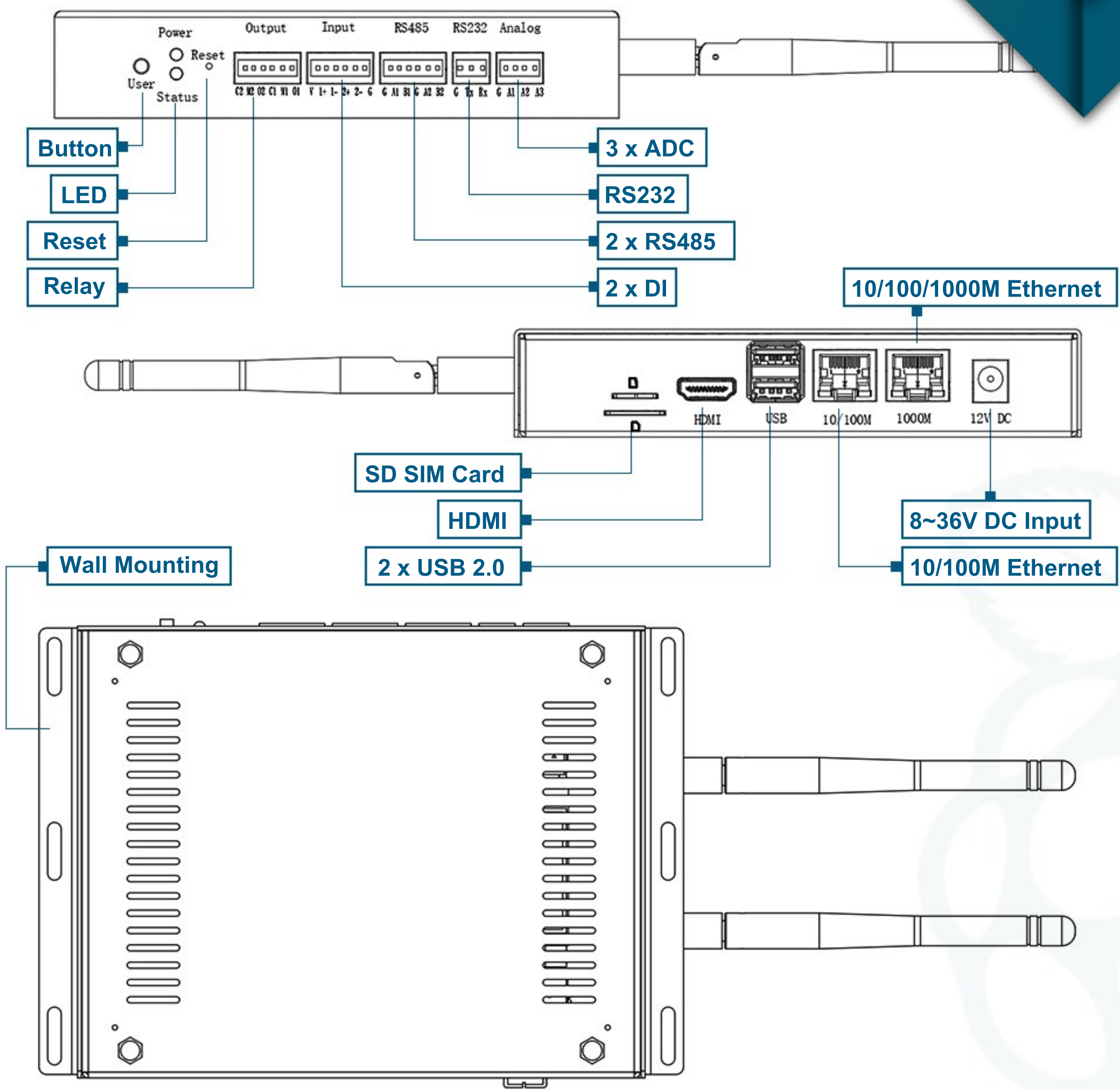

Dimension Unit:mm

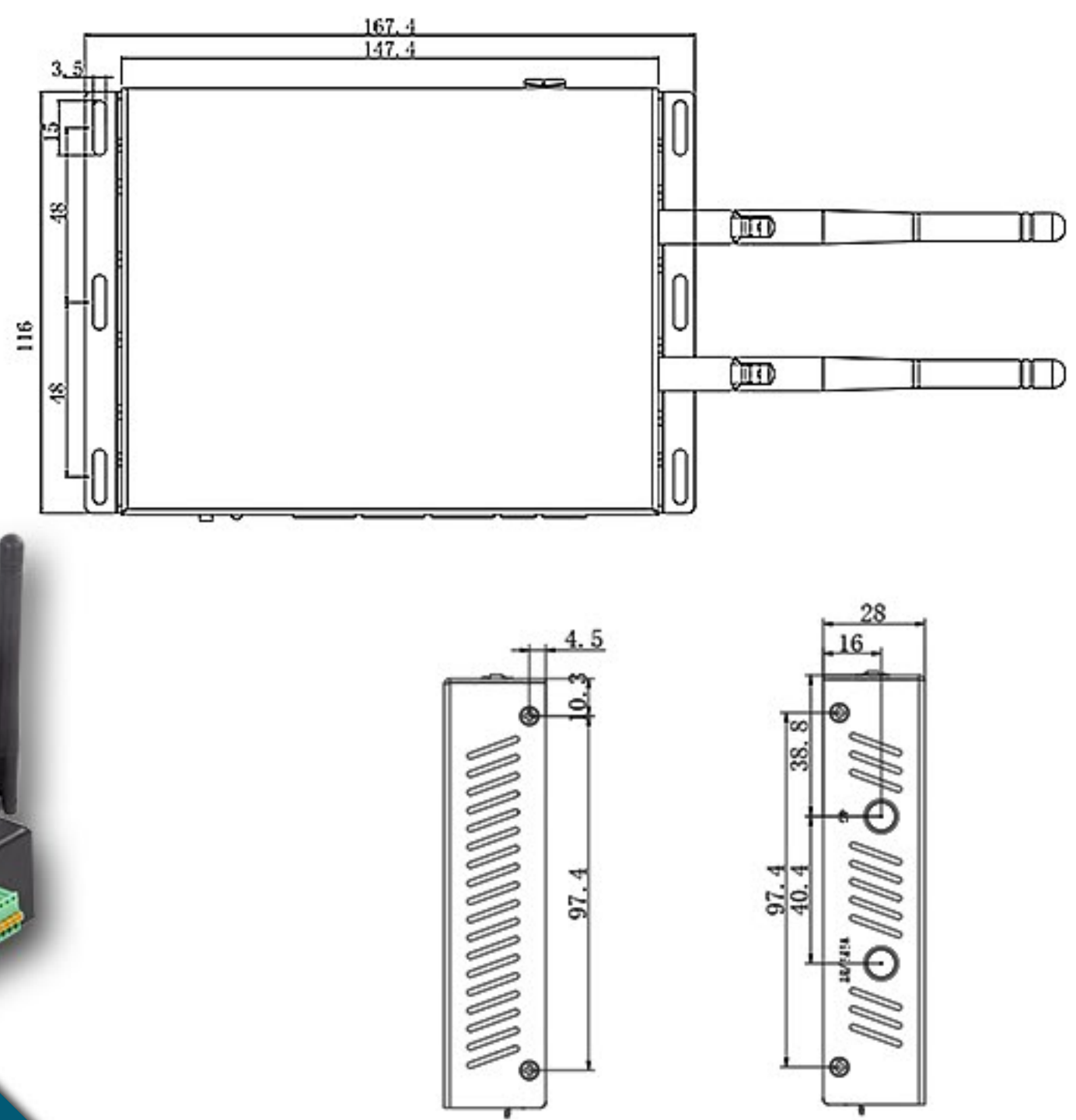

CM4 Media

CM4 Media is a multimedia computer based on Raspberry Pi Computer Module 4, which provides 8M pixel Camera, MEMS Microphone, Stereo Speakers and SSD hard disk. The case is made by aluminum CNC cut process, which provides excellent cooling performance, make sure the computer is always working at the full speed.

Highlight

- ◆ Powerful performance with Quad-core CPU, up to 8GB RAM and SSD support
- ◆ Dual Displays with 4K output
- ◆ Premium audio with stereo speakers, MEMS microphone integrated and Headphone Jack support
- ◆ Fast networking with Gig-Ethernet, Dual-band WiFi, Bluetooth and optional 4G LTE
- ◆ Compact, beautiful, silent and energy-efficient



A Very Think 4K Ultra HD Streaming Media Computer

<https://www.edatec.cn/en/elpc/cm4-media.html>

SPECIFICATIONS



Category	Feature
Processor	Broadcom BCM2711 quad-core Cortex-A72 (ARM v8) 64-bit H.265 (HEVC) (up to 4Kp60 decode), H.264 (up to 1080p60 encode) OpenGL ES 3.1, Vulkan 1.0
RAM	1GB / 2GB / 4GB / 8GB LPDDR4-3200 SDRAM
Storage	Onboard 0GB / 8GB / 16GB / 32GB eMMC 1x microSD Card Slot for system boot when choosing 0GB(CM4 Lite) eMMC Optional SSD Hard Disk Drive, support system boot (Capacity can be from 120GB ~ 1TB)
Display	1x standard HDMI Out (Type A) 1x micro HDMI Out (Type D)
Camera	Optional Onboard SONY IMX219 8-megapixel Camera
Audio	Built-in WM8960 Low power, High Quality Stereo CODEC Onboard 2 channel 1W Stereo Speakers Onboard 1 channel MEMS microphone Support headphone jack and external microphone
Wired Interface	1x Gig-Ethernet (10/100/1000M) 2x USB 3.0 Type-A 1x USB 2.0 Type-A
Wireless	Optional 2.4 GHz, 5.0 GHz IEEE 802.11 b/g/n/ac wireless and Bluetooth 5.0, BLE with external antenna Optional 4G LTE (non-SSD Hard Disk version), 1x micro-SIM card slot
System	1x RTC with CR1220 backup
Expansion Interface	1x mini PCIe with 5Gb/s SATA and USB 2.0, compatible with 4G LTE Module and mSATA SSD Drive
Power In	5V/3A DC USB Type-C
Buttons	1x Power button with Blue indicator
Indicator	1x Power Indicator integrated in Power button 1x Status Indicator with Green LED
Operating Temperature Range	0~ 60°C
Operating Humidity	10% - 60%
Case	Aluminum Alloy Case, 1 Antenna Holes
Dimension	100(L) x 100(W) x 19(H) mm
Mounting Options	Desktop
OS	Pre-installed with 32-bit Raspberry Pi OS with Desktop in eMMC or SSD Compatible with Origin Raspberry Pi OS, support 32-bit and 64-bit OS, support Lite and Desktop versions Support BSP online install / upgrade with APT tool

Interface Diagram

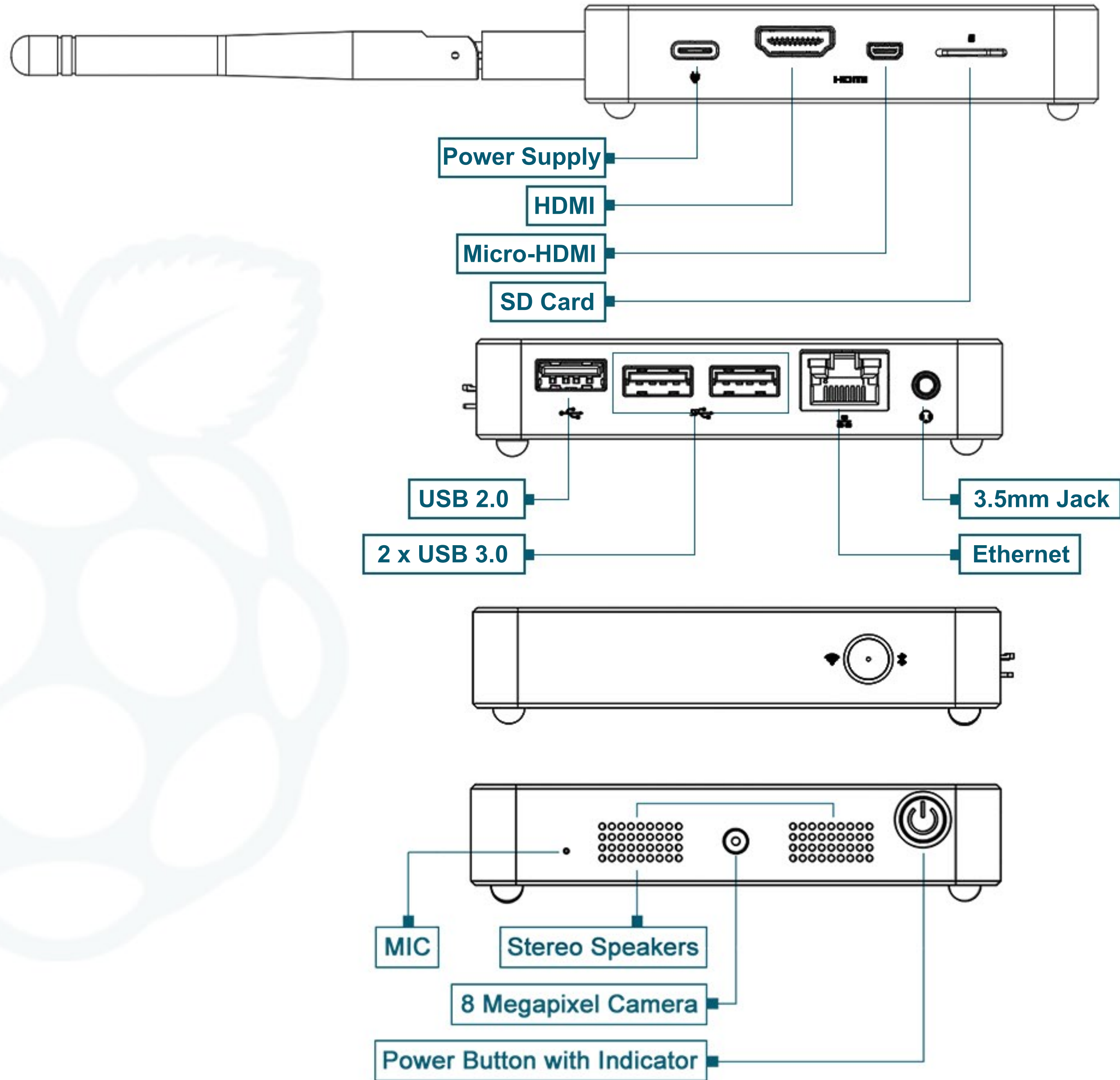

Order Information

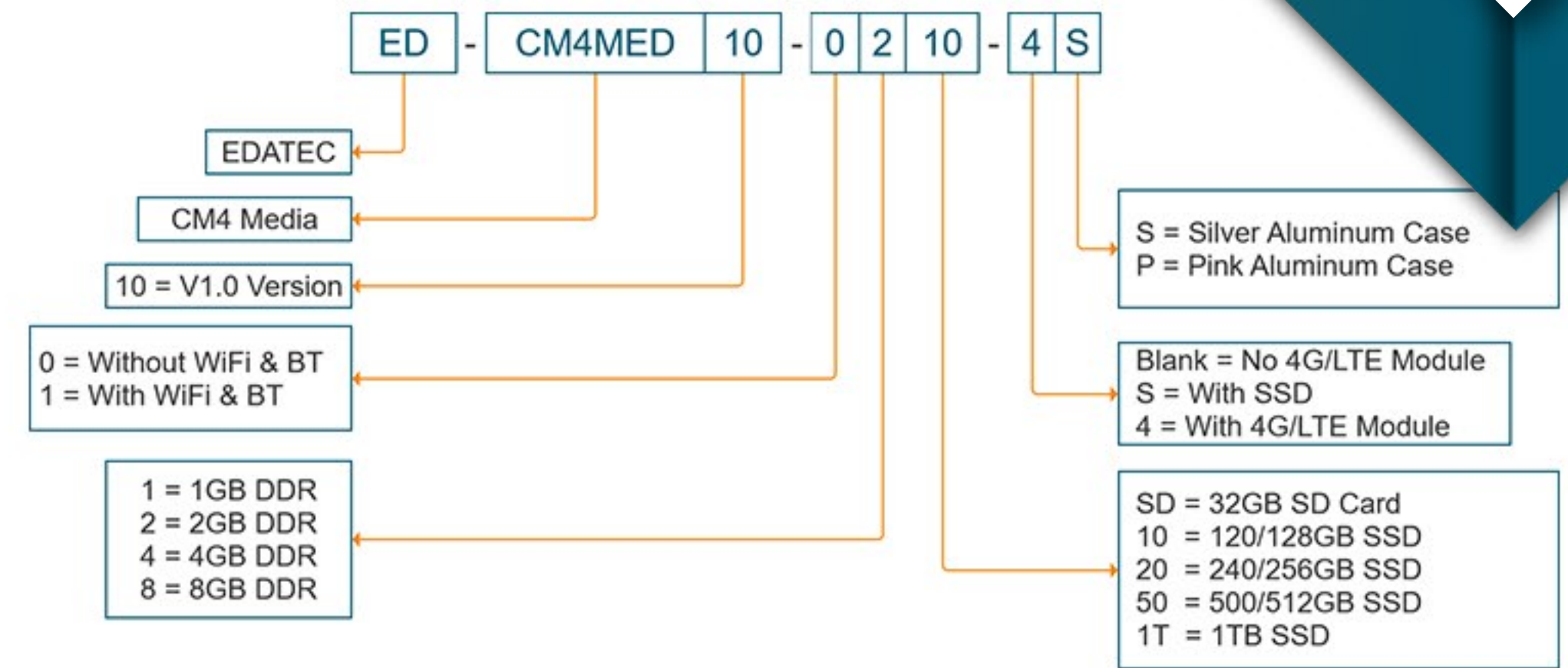

Dimension

Unit:mm

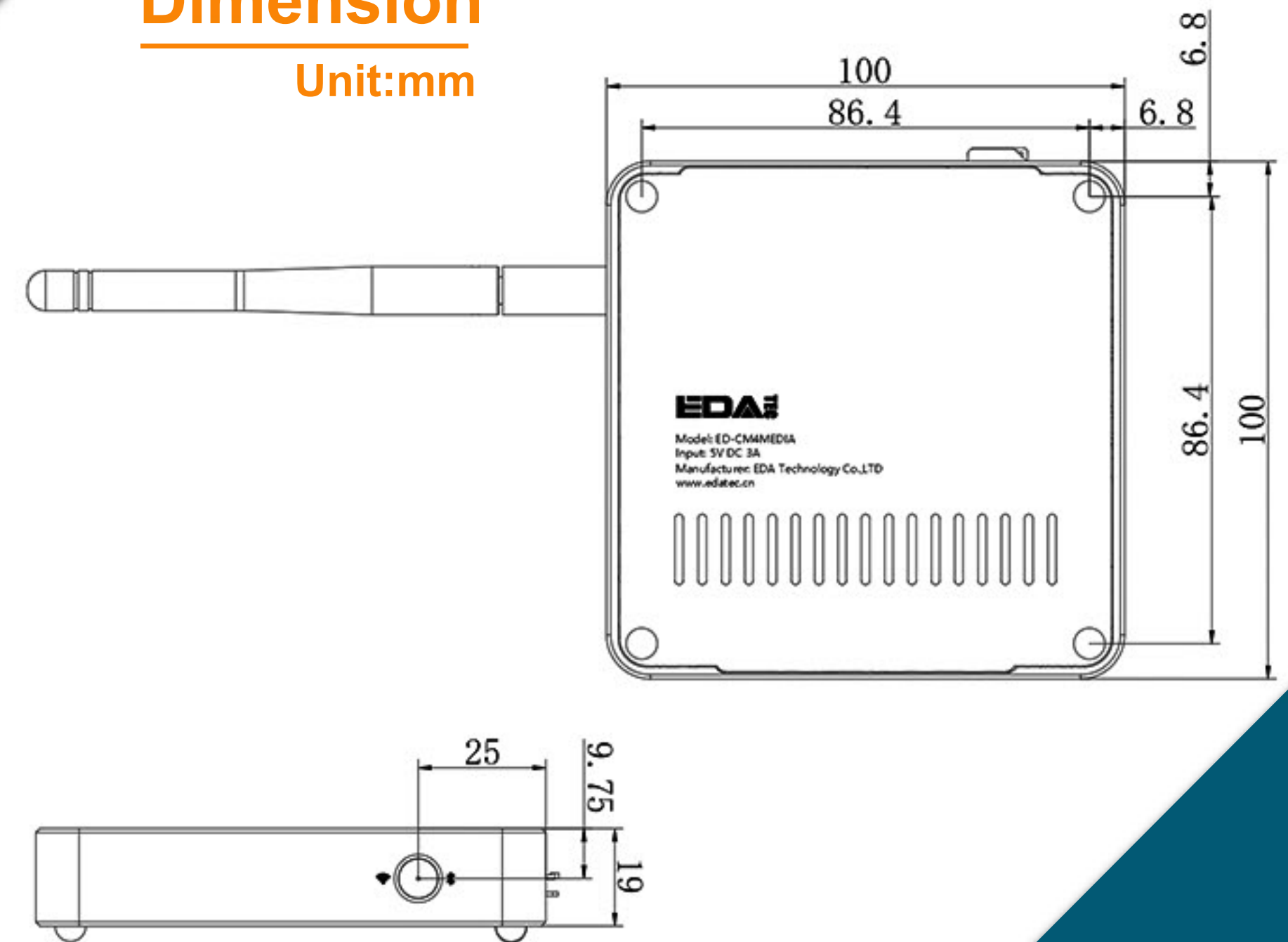

A Highly Configurable Fanless Computer for Industrial Internet of Things.

ED-IPC2120 is a highly configurable, Raspberry Pi CM4 powered computer, specifically designed for Industrial Internet of Things. It features a quad-core ARM Cortex-A72 processor with 1GB / 2GB / 4GB / 8GB RAM and 8GB /16GB /32GB eMMC Flash.

It supports a wide range of networking including 2 channels of Ethernet (1x Gig-Ethernet and 1x 100M Ethernet), optional Dual-band WiFi and Bluetooth with external antenna, and optional 4G LTE with GPS support.

For storage, besides the on-board eMMC Flash, it also supports micro-SD card and M.2 Slot for NVMe SSD. User can use eMMC to install the operating system and store the application data, at the same time, user can use SD card to store large user data, compare to the built-in eMMC memory, SD card can offer larger capacity and its cost is more effective. If your application needs high performance storage, NVMe storage is, on average, 12x faster for normal file operations (copies, random read/write).

It has a rich set of industrial bus, up to 5 channels of isolated RS485, up to 2 channels of RS232 and 1 channel of CAN.

ED-IPC2120 also has some additional features that can make it always stable and reliable. It has a built in battery-powered real-time clock, watchdog time and a super capacitor based UPS, which can support safe shutdown when power failure occurs.

ED-IPC2120 is also extensible. Thanks to the 40-PIN GPIO and USB 2.0 B2W connector, we can get some extra hardware features for some special applications, for example: digital isolated input or output, Analog input or output. The expansion board can be stacked into the main board and can be built into one box. We have already built several expansion boards for read-to-use.

The system supports +9~28V DC power input from terminal block with screw lock support. The whole side aluminum alloy heat sink can provide excellent cooling performance for CPU, wireless module and PMU, the whole system can work reliably in a high temperature environment.

The dimension of ED-IPC2120 is about 130*73*32mm. It comes with four M2.5 screw holes for equipment installing, it also supports DIN rail mounting.

Highlight

- ◆ Powerful performance with a quad-core ARM CPU, up to 8GB RAM, up to 32GB eMMC, SD card for data storage, M.2 NVMe SSD support and 4K HDMI output
- ◆ Fast networking with 2 channels of Ethernet, optional dual-band WiFi and Bluetooth and optional 4G LTE with GPS support
- ◆ A rich set of Industrial IoT bus including up to 5x isolated RS485, up to 2x RS232 and 1x isolated CAN
- ◆ On-board SuperCAP based UPS, watchdog and RTC can make it stable and reliable.
- ◆ Expansionable with several ready-to-use modular I/O modules
- ◆ Compact metal case with excellent cooling performance, support DIN rail mounting

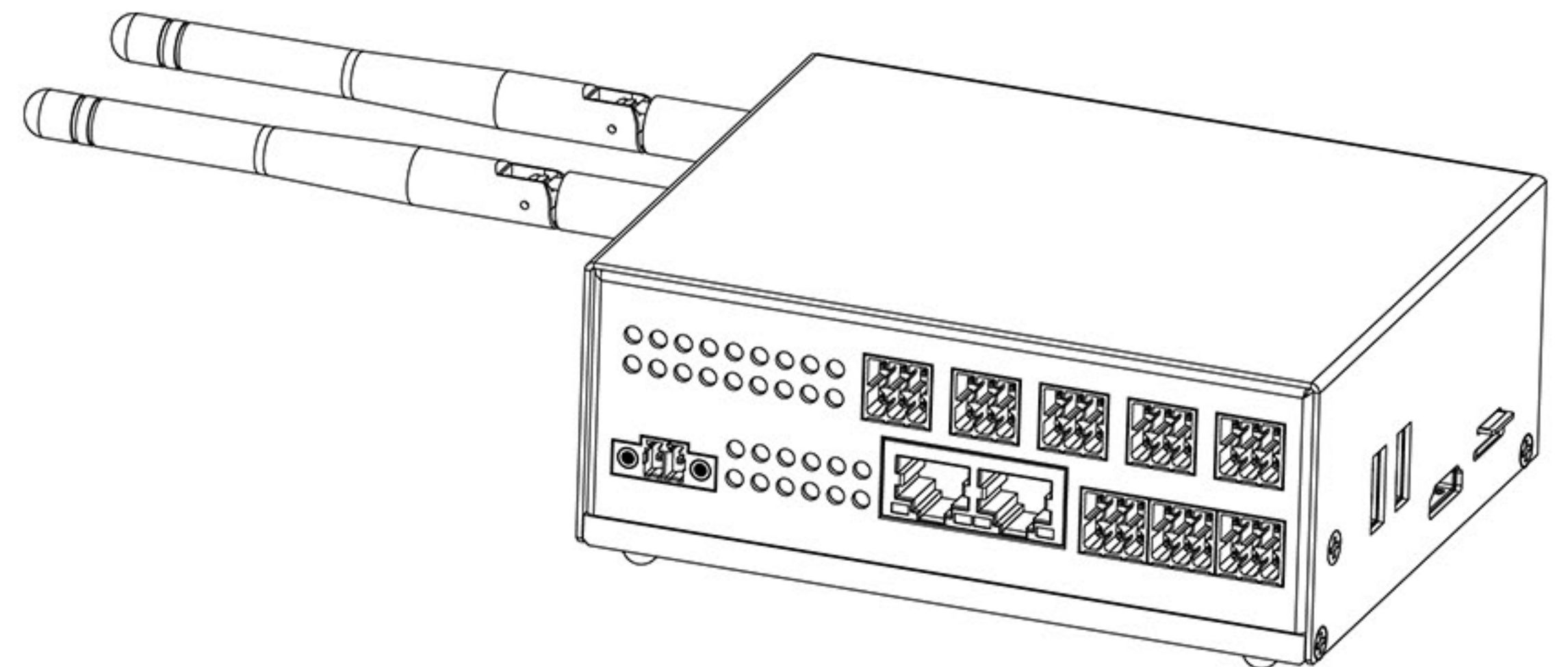

SPECIFICATIONS

Item	Feature
Processing capability	Broadcom BCM2711 quad-core Cortex-A72 (ARM v8) 64-bit SoC @ 1.5GHz H.265 (HEVC) (up to 4Kp60 decode), H.264 (up to 1080p60 decode, 1080p30 encode) OpenGL ES 3.1, Vulkan 1.0 1GB / 2GB / 4GB / 8GB LPDDR4
Interface	2x USB 2.0 Type-A 1x M.2/NGFF slot with 1-lane PCIe for Nvme SSD and WiFi6 module support 1x mini-PCIe with 1x USB 2.0 for 4G Module supporting 3x isolated RS-485, Phoenix Terminal, 3 Pos 2x RS232 / RS485. It can be configurated to RS485 (isolated) or RS232 by an on-board switch 1x isolated CAN
Connectivity	1x Gig-Ethernet(10/100/1000M) from CM4 1x Fast-Ethernet(10/100M) from USB 2.0
Wireless	Optional 2.4 GHz, 5.0 GHz IEEE 802.11 b/g/n/ac wireless and Bluetooth 5.0, BLE with external antenna Optional 4G LTE with GPS support, 1x Nano-SIM card slot

Item	Feature
Storage	8GB / 16GB / 32GB eMMC for system boot 1x microSD Card for Data Storage, can work with eMMC together at the same time Optional Nvme SSD from M.2 slot
Expansion Interface	40-Pin GPIO compatible with Raspberry Pi HAT, 2x20 2.54mm Pin Header 1x USB Pin Header with 2x USB 2.0
Camera and Display	1x FPC CSI Camera, 2-lane CSI, can support Raspberry Pi official Camera Module 1x standard HDMI Out (Type A) 1x FPC HDMI Touch Display, can support a wide range panels from EDATEC 1x FPC DSI Touch Display, can support a wide range panels from EDATEC
System	1x RTC with CR2232 backup 1x Watchdog Time Low Voltage Detect 1x Buzzer
Security	ATECC608 crypto-auth chip
Indicator	1x Power Indicator with Red LED 1x Status Indicator with Green LED 1x 4G network indicator Industrial bus indicators for RS485, RS232 and CAN
Power	9 ~ 28V DC In from terminal block with screw lock support Super Capacitor for system power backup to do a safe shutdown when power failure
Dimension	130(L) x 80(W) x 40(H) mm
Case	Support DIN Rail, Support Mounting
Antenna	WiFi, 4G Antanna, GPS
Software Environment	Raspberry Pi OS (Debian based)
Modular IO Module#1	8x isolated DI with indicator support 8x isolated DO with indicator support 1x isolated CAN with indicator support

Dimension Unit:mm

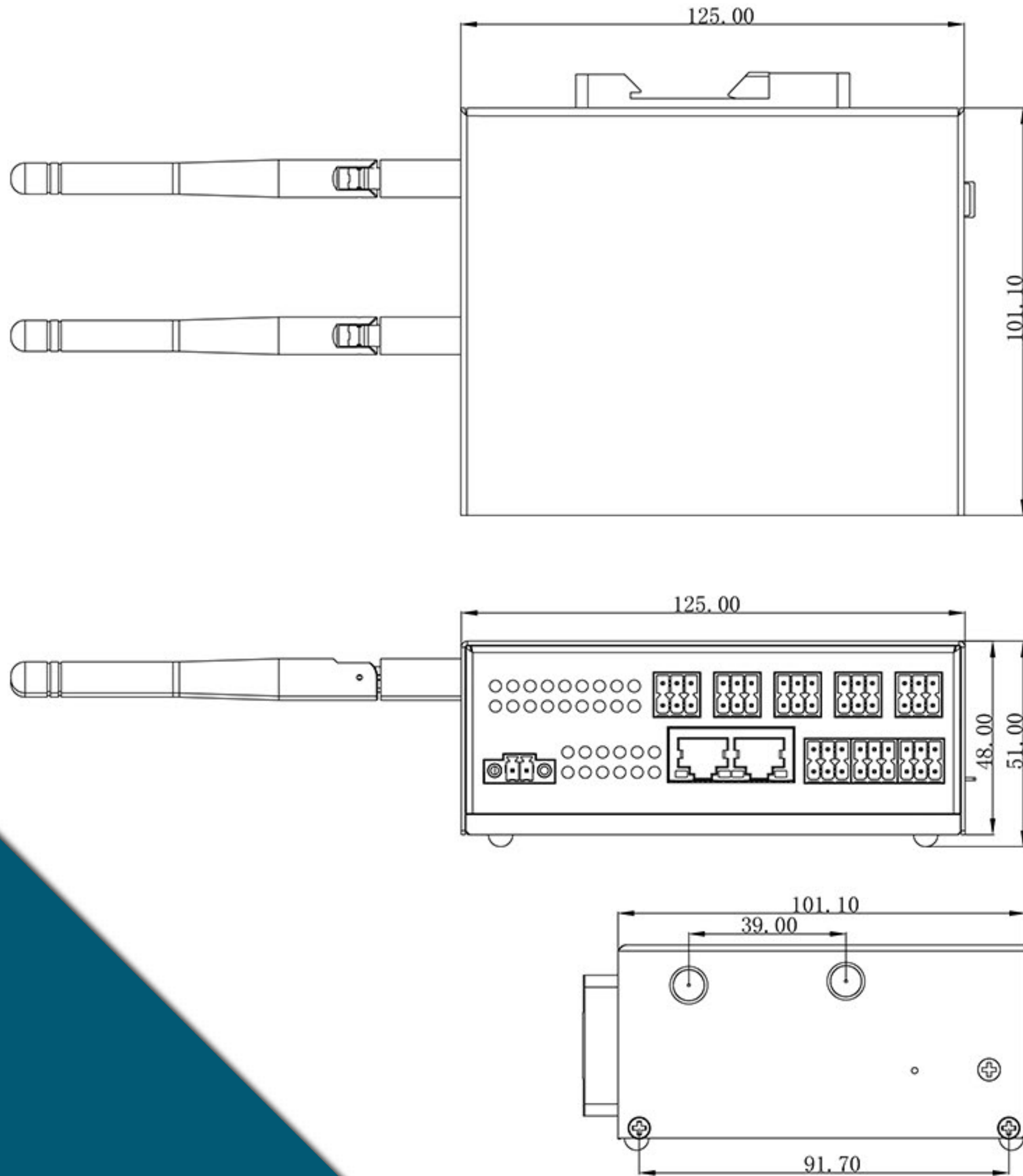

Dimension Unit:mm

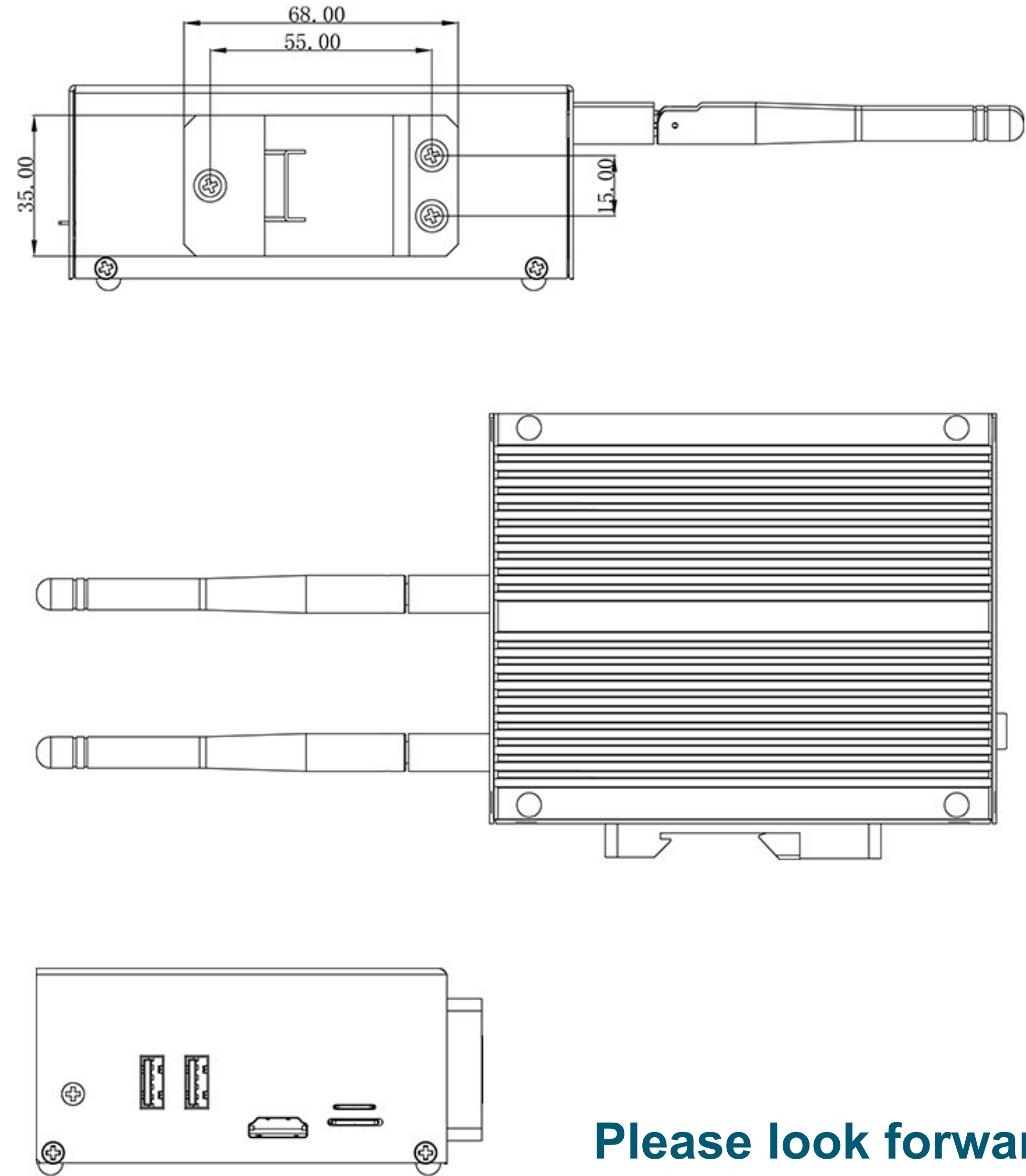

Please look forward to it!

ED-MVB2010 | In Development

A Highly Configurable Fanless Computer for Machine Vision.

ED-MVB2010 is a highly configurable, Raspberry Pi CM4 powered computer, specifically designed for Machine Vision. It features a quad-core ARM Cortex-A72 processor with 1GB / 2GB / 4GB / 8GB RAM and 8GB / 16GB / 32GB eMMC Flash.

It comes with 1 standard HDMI port can support 4Kp60 video output, 1 FPC 4-lane DSI interface and 1 FPC HDMI interface can support a wide range of touch panels from EDATEC.

It has a set of rich high-speed interfaces, including 3 channels of Ethernet, 1x USB 3.0 and 2x USB 2.0 ports.

For storage, besides the on-board eMMC Flash, it also supports micro-SD card and mSATA SSD. User can use eMMC to install the operating system and store the application data, at the same time, user can use SD card to store large user data, compare to the built-in eMMC memory, SD card can offer larger capacity and its cost is more effective. If your application needs high performance storage, you can use the mSATA SSD.

It also has a rich set of industrial interfaces, including 1 channel of isolated RS485, 1 channel of RS232, 4 isolated digital input and 4 isolated digital output.

It integrates a constant-current driver with 256 grade modulation, supporting up to 3 channels lighting power with standard SMP-03V-BC connector. In this way, Users don't need any extra lighting control unit for machine vision applications.

It supports an optional dual-band WiFi and Bluetooth with external antenna, and optional 4G LTE with GPS support.

ED-MVB2010 also has some additional features that can make it always stable and reliable. It has a built-in battery-powered real-time clock, watchdog time and a crypto-auth chip for IP protection.

ED-MVB2010 is also expansionable. Thanks to the 40-PIN GPIO and USB 2.0 B2W connector, we can get some extra hardware features for some special applications, for example: digital isolated input or output, Analog input or output. The expansion board can be stacked into the main board and can be built into one box. We have already built several expansion boards for read-to-use.

The system supports +9~28V DC power input from terminal block with screw lock support. The whole side aluminum alloy heat sink can provide excellent cooling performance for CPU, wireless module and PMU, the whole system can work reliably in a high temperature environment.

ED-MVB2010 is compact. The dimension is about 130*73*45mm. It comes with four M2.5 screw holes for equipment installing, it also supports DIN rail mounting.

Highlight

- ◆ Powerful performance with a quad-core ARM CPU, up to 8GB RAM, up to 32GB eMMC, SD card for data storage, mSATA SSD support and 4K HDMI output
- ◆ Rich high-speed interfaces for vision camera with 3x Gig-Ethernet and 1x USB 3.0 and 2x USB 2.0
- ◆ Constant-current driver with 256 grade modulation for up to 3 channels lighting power
- ◆ A rich set of Industrial interfaces including 1x isolated RS485, 1x RS232, 4x isolated DI, 4x isolated DO
- ◆ On-board crypto-auth chip for IP protection
- ◆ Compact metal case with excellent cooling performance, support DIN rail mounting

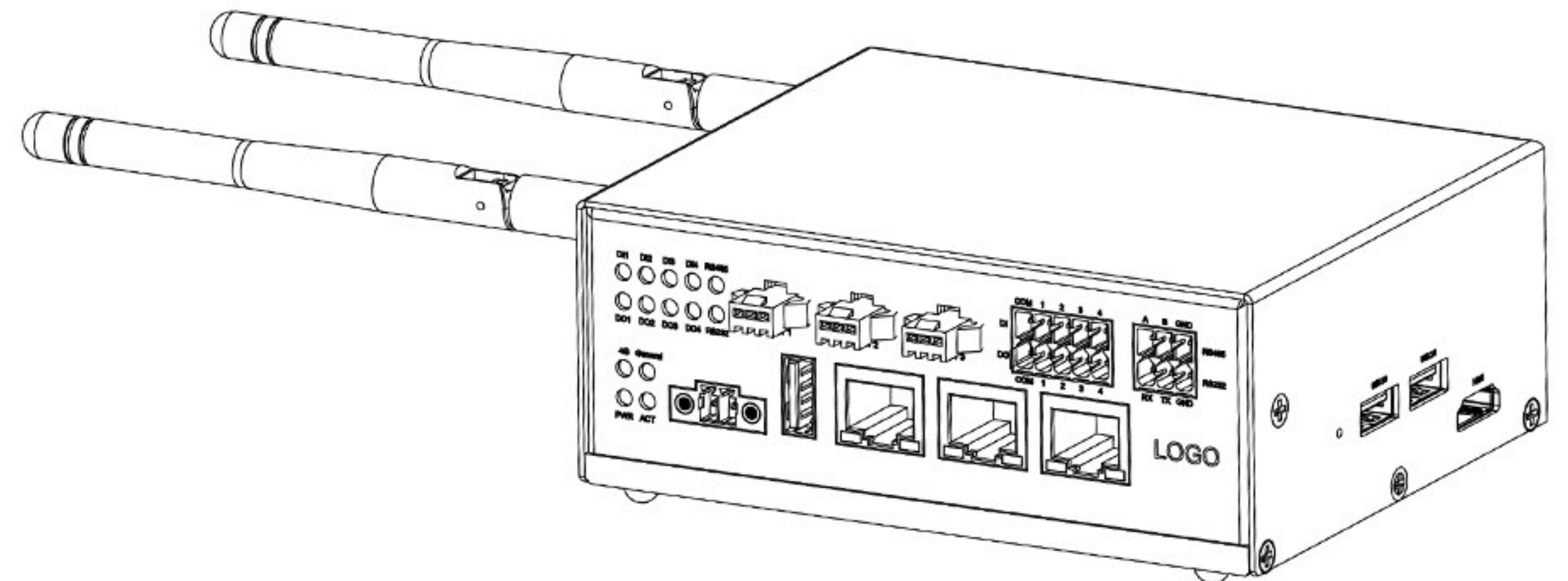

SPECIFICATIONS

Item	Feature
Processing capability	Broadcom BCM2711 quad-core Cortex-A72 (ARM v8) 64-bit SoC @ 1.5GHz H.265 (HEVC) (up to 4Kp60 decode), H.264 (up to 1080p60 decode, 1080p30 encode) OpenGL ES 3.1, Vulkan 1.0 1GB / 2GB / 4GB / 8GB LPDDR4
Interface	1x USB 3.0 Type-A 2x USB 2.0 Type-A 1x mini-PCIe slot with 1x USB 3.0 for mSATA SSD support 1x mini-PCIe with 1x USB 2.0 for 4G Module supporting 3x USB 2.0, Pin Header 1x isolated RS-485 1x isolated RS232 4x isolated DI with indicator support 4x isolated DO with indicator support
Connectivity	3x Gig-Ethernet(10/100/1000M) from CM4
Wireless	Optional 2.4 GHz, 5.0 GHz IEEE 802.11 b/g/n/ac wireless and Bluetooth 5.0, BLE with external antenna Optional 4G LTE with GPS support, 1x Nano-SIM card slot

Item	Feature
Storage	8GB / 16GB / 32GB eMMC for system boot 1x microSD Card for Data Storage, can work with eMMC together at the same time Optional mSATA SSD
Expansion Interface	40-Pin GPIO compatible with Raspberry Pi HAT, 2x20 2.54mm Pin Header 1x USB Pin Header with 2x USB 2.0
Camera and Display	1x standard HDMI Out (Type A) 1x FPC HDMI Display with USB Touch support, can support a wide range panels from EDATEC 1x FPC DSI Touch Display, can support a wide range panels from EDATEC 1x FPC CSI Camera, 2-lane CSI, can support Raspberry Pi official Camera Module
System	1x RTC with CR1220 backup 1x Watchdog Time 1x Buzzer
Security	ATECC608 crypto-auth chip
Lighting	Lighting 3x Lighting Interface with standard SMP-03V-BC connector
Indicator	1x Power Indicator with Red LED 1x Status Indicator with Green LED 1x 4G network indicator Industrial bus indicators for RS485, RS232 and DI, DO
Power supply	9 ~ 28V DC In from terminal block with screw lock support 2x power in connector, one for normal use and the other for high power consumption scenarios, lighting for example
Dimension	130(L) x 80(W) x 40(H) mm
Case	Metal Case, support DIN Rail, support Mounting
Antenna	WiFi, 4G Antenna, GPS
Software Environment	Raspberry Pi OS (Debian based)

Dimension Unit:mm

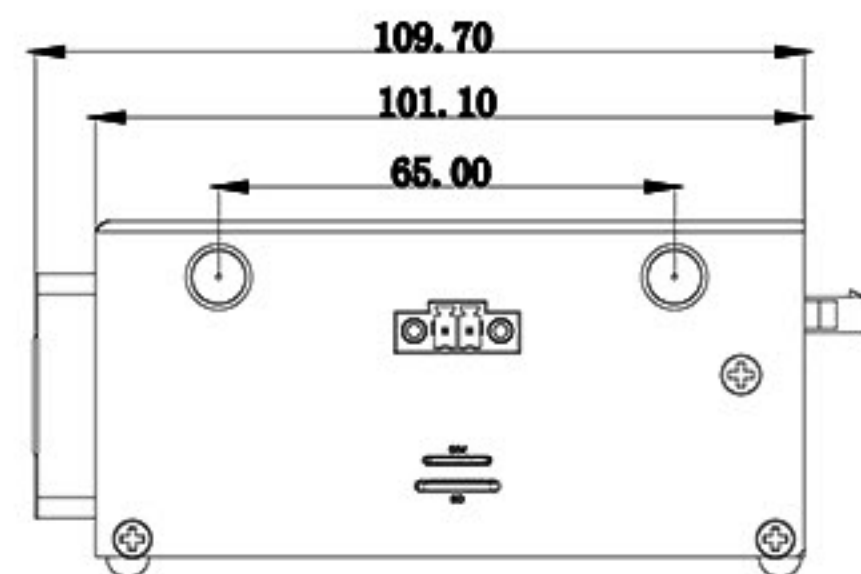
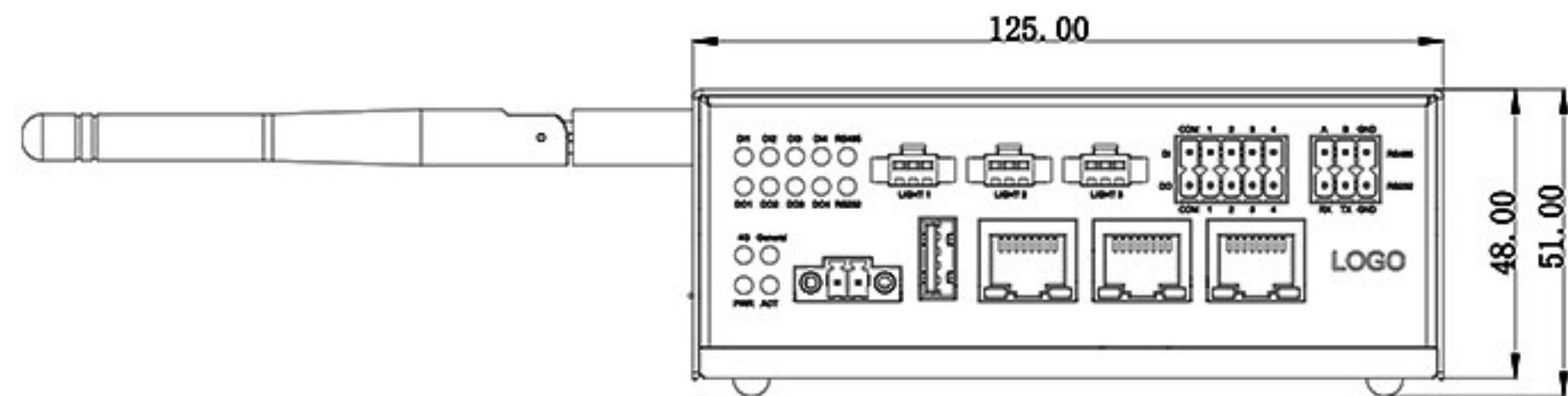
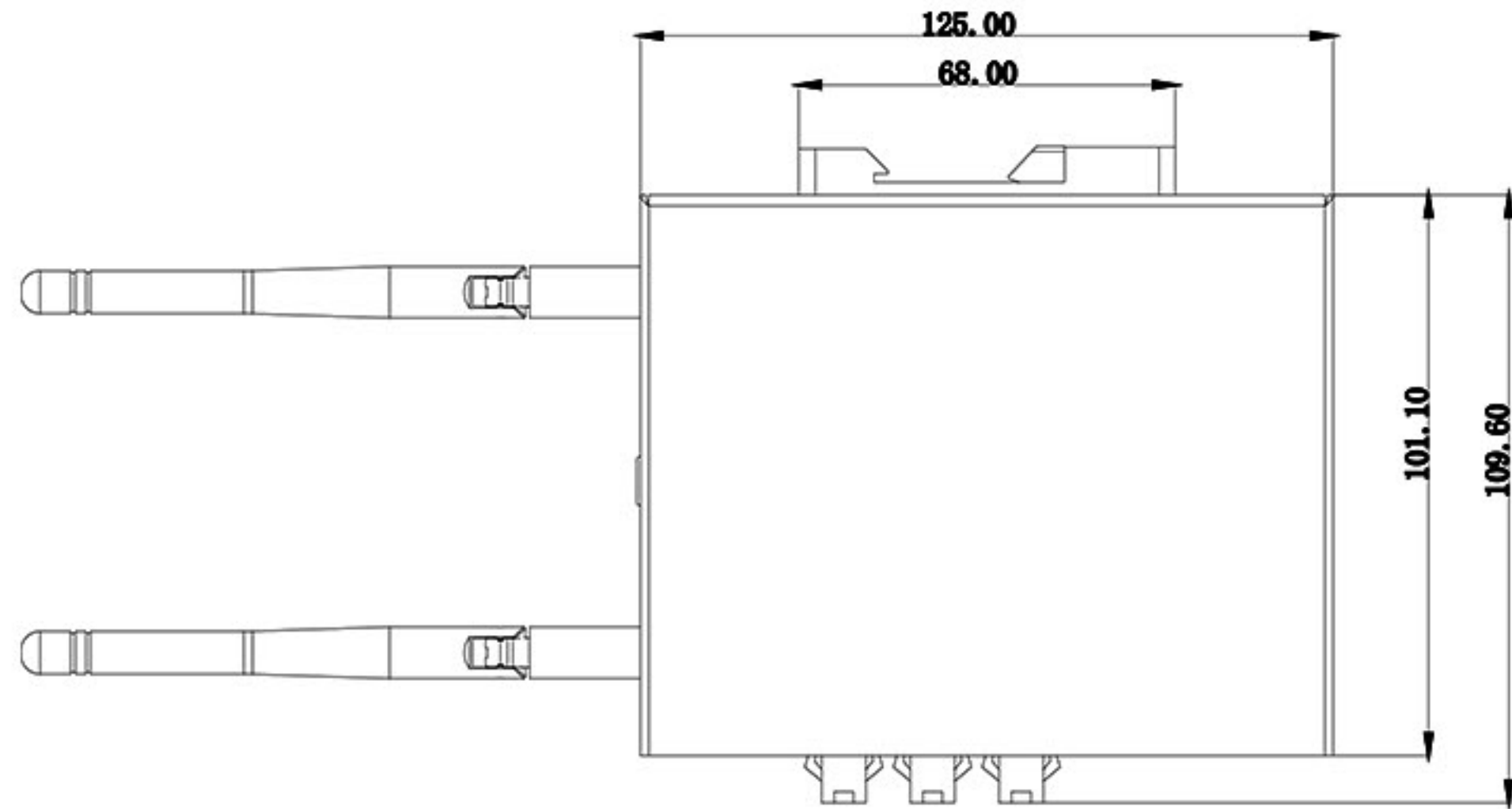

Wireframe Diagrams

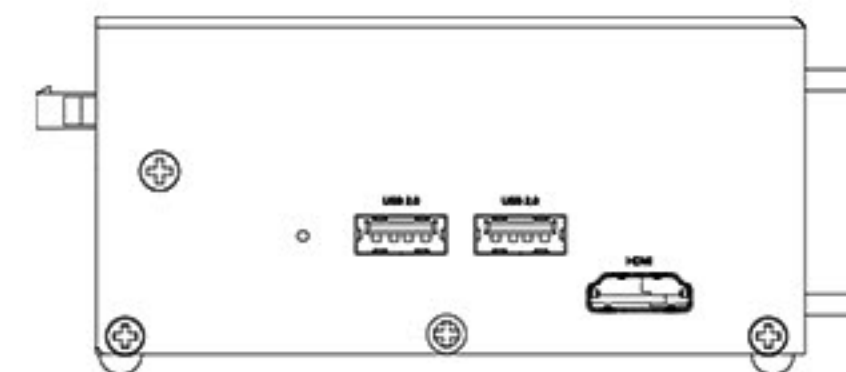
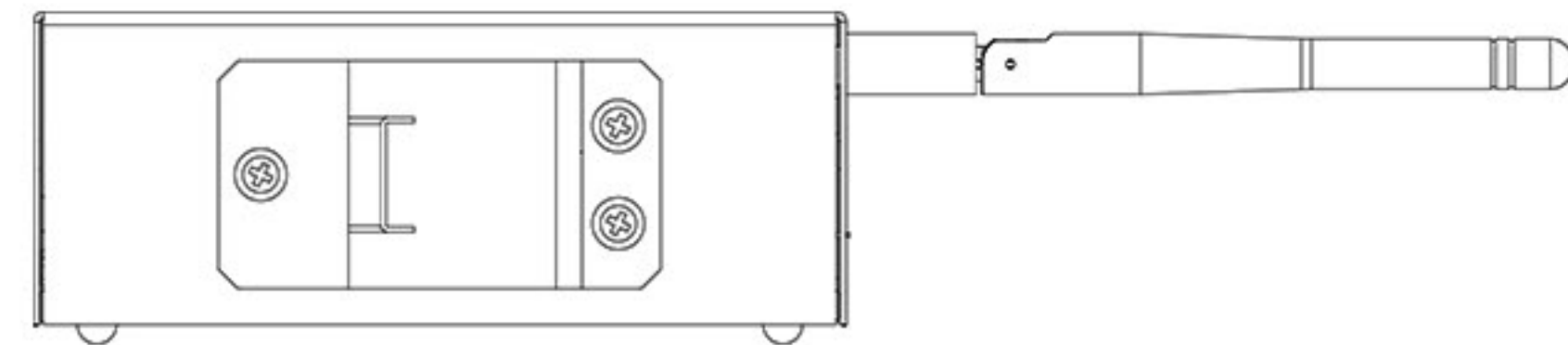
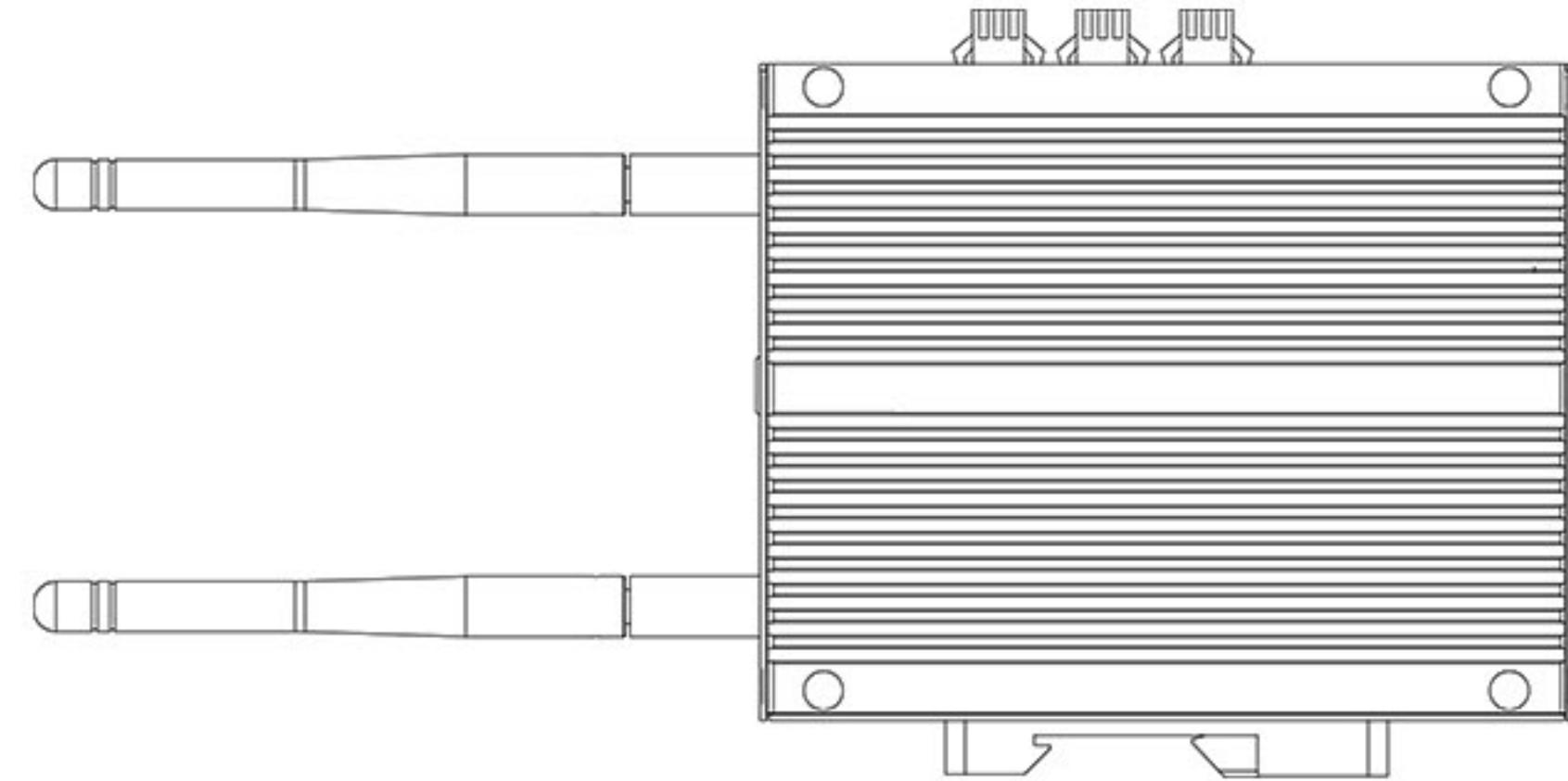

Please look forward to it!

IoT Gateway

ED-IoT Gateway is based on Raspberry Pi Compute Module, supports CM3+/CM3/CM1 full series solution , specially designed for IoT application, it provides rich wireless communication capability including WiFi, Bluetooth, 4G Module(Optional) & LoRa(Optional), this solution also supports various wired communication capability such as 10/100M Ethernet, USB2.0, UART and RS485. On board 2Kb EEPROM and 32Mb Serial Flash can be used to store the system data and user data.

Highlight

- ◆ Based on **Raspberry Pi Compute Module**, supports **CM3+/CM3/CM1**, specially for IoT application
- ◆ Rich wireless communication capability including **WiFi, Bluetooth, 4G Module(Optional) & LoRa(Optional)**, **10/100M Ethernet, USB2.0, UART and RS485**
- ◆ Diverse interface with **CSI,DSI**, and powerful video **CODEC** capability
- ◆ On board **RTC**, temperature sensor and low voltage detector
- ◆ Support **Raspberry Pi Standard 40 Pins Connector, Mini PCI-e and 24 Pins DIP connector**



SPECIFICATIONS

Item	Feature
Raspberry Pi Compatibility	Raspberry Pi Compute Module 1 Raspberry Pi Compute Module 3 Raspberry Pi Compute Module 3 Lite Raspberry Pi Compute Module 3+ 8 GB / 16 GB / 32 GB eMMC flash Raspberry Pi Compute Module 3+ Lite
Connectivity	1 x 10/100M Ethernet 2 x USB2.0 1 x USB Slave for system programming 3 x UARTs(TTL Signal) 1 x RS485 with Lightning Protection
Wireless	1 x WiFi complies with IEEE802.11b/g/n Standard 1 x Bluetooth 4.1 4G /LTE Module by Mini PCI-e connector (Optional) LoRa Concentrator Gateway Module by 24pins DIP connector (Optional)
Storage	1 x microSD card slot On Board 2Kb EEPROM On Board 32Mb serial Flash
System Monitoring	On Board RTC On Board Low Voltage Detector(LVD) 1x high precision temperature sensor
User Interface	1 x Red & 1 x Green LED Indicator 1 x System Reset Button 1 x Custom User Button 1 x Buzzer
Expansion Interface	1 x USB Interface by Mini PCI-e Socket 1 x USB Interface by a 4pins DIP connector 1 x High Speed SPI by 24pins DIP connector 1 x Raspberry Pi Standard 40Pins Connector
Camera & Display	1 x CSI supports the standard CSI cameras 1 x HDMI 1 x DSI supports Raspberry Pi Official Display
Power Supply	7 ~ 18V DC Input by Phenix Connector
Dimensions	160 mm(L) x 120 mm(W) x 20mm(H)
Software Environment	Raspberry Pi Raspbian OS installed



Order Information

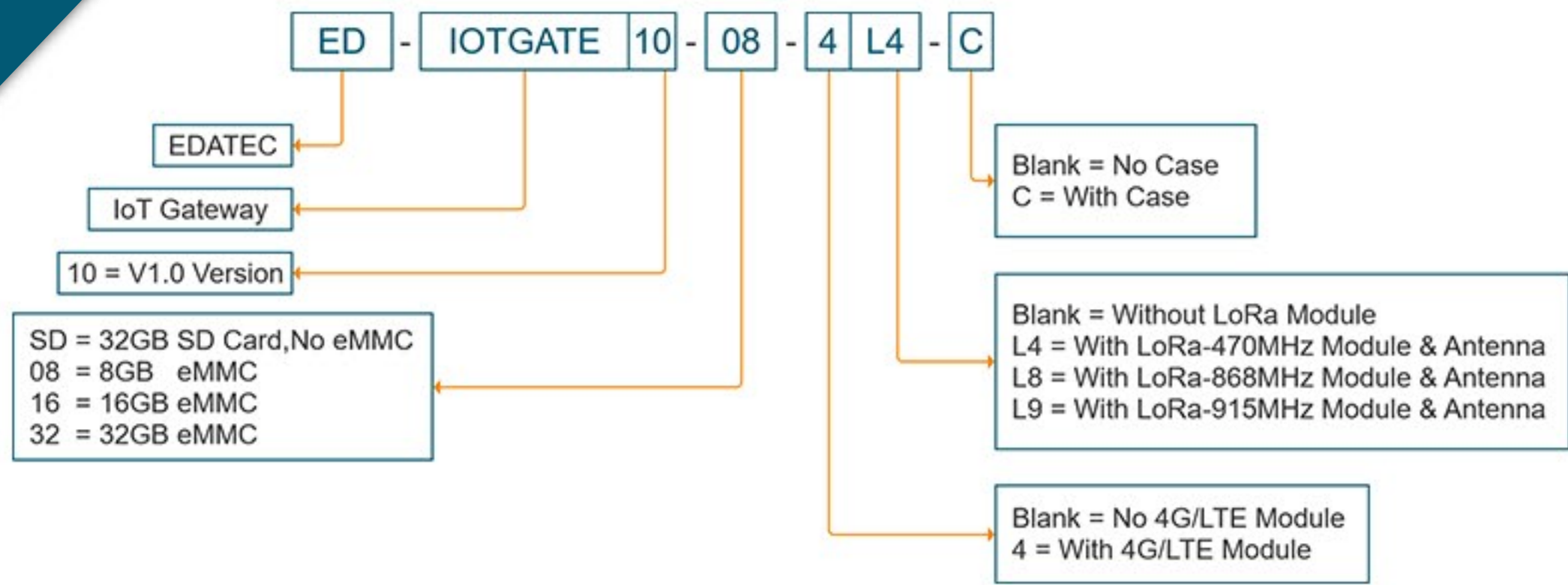

Interface Diagram

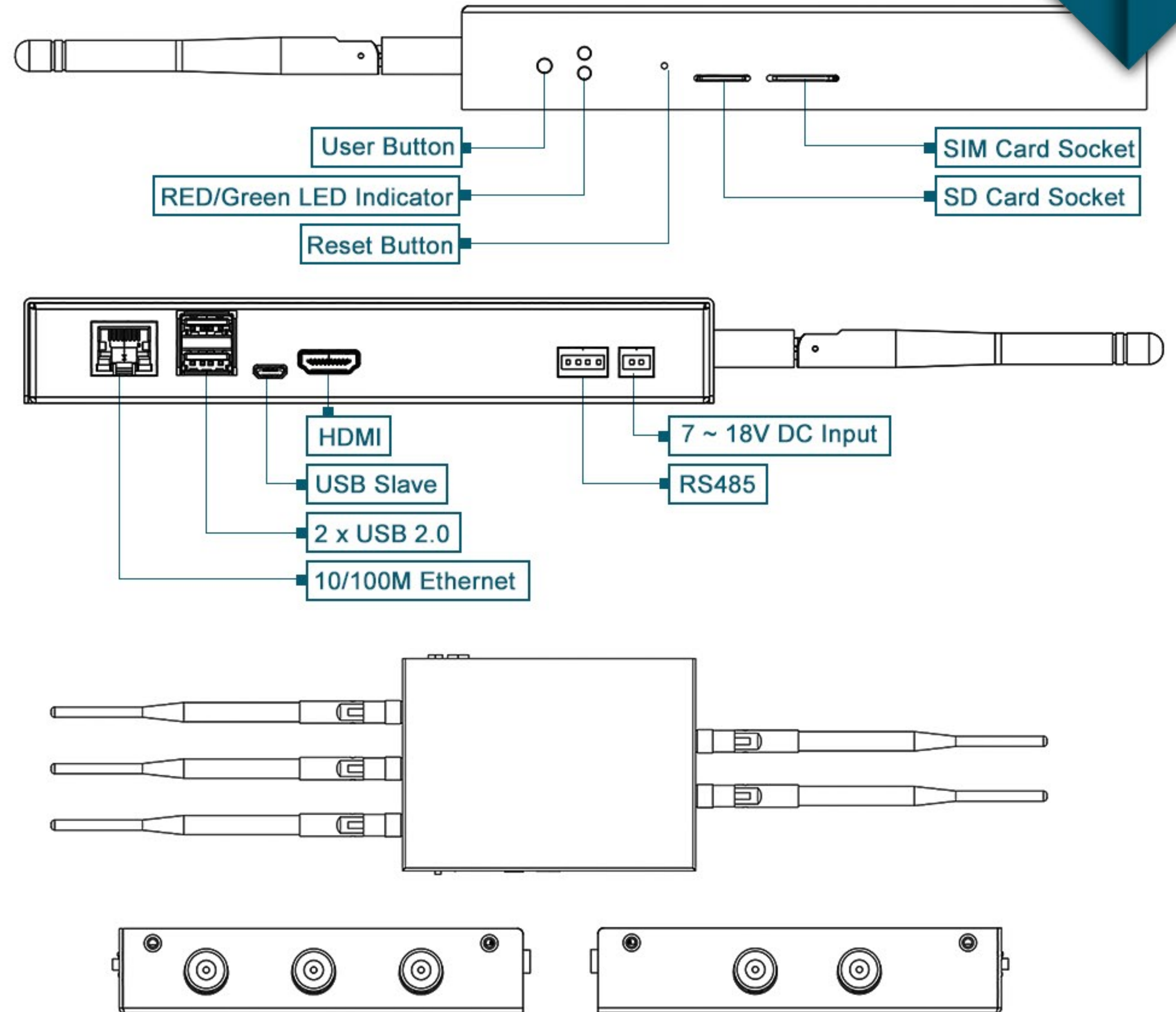

Dimension

Unit:mm

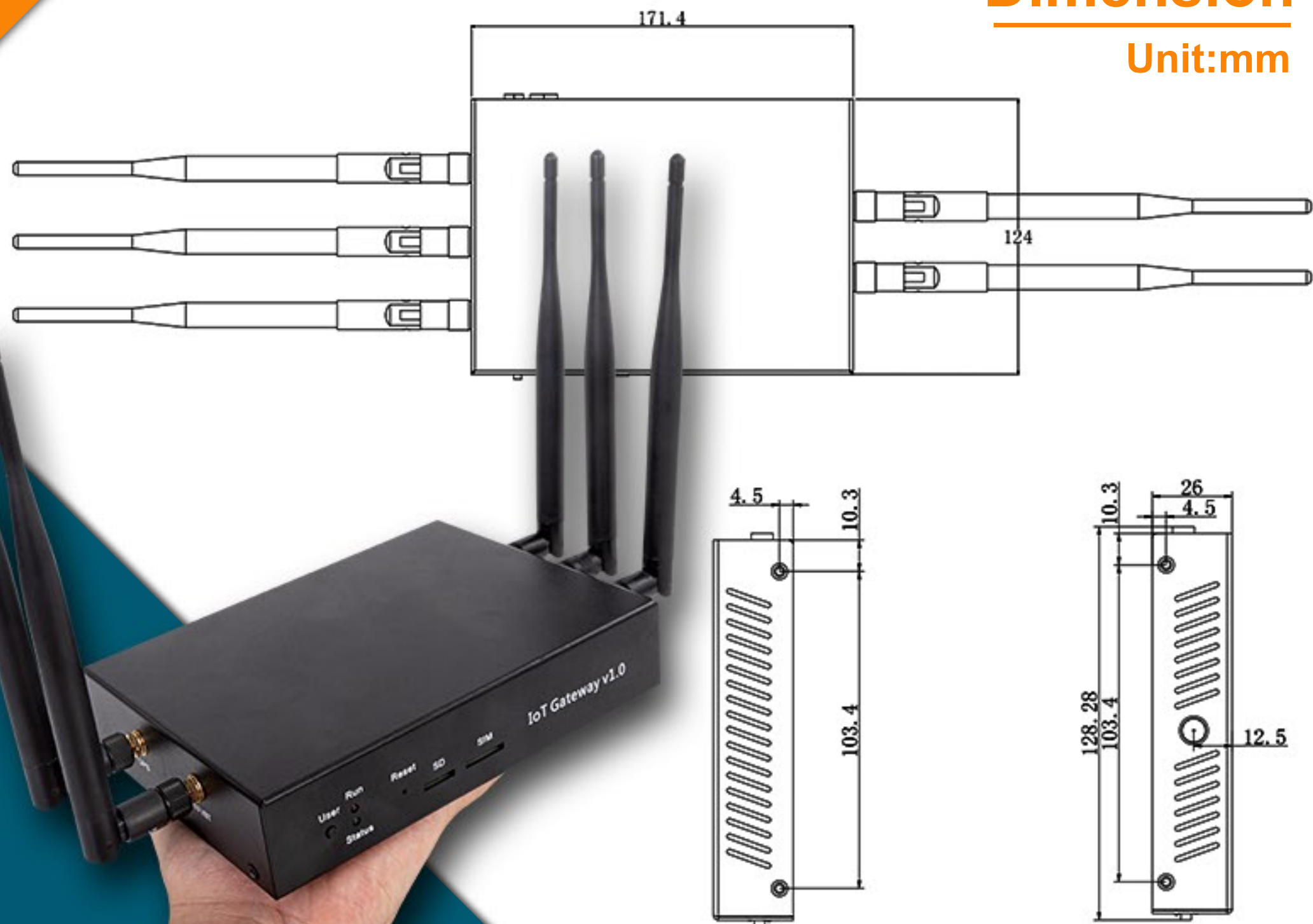

ED-IoTHotspot-M1

ED-IoTHotspot-M1 is a Helium Indoor Light Hotspot designed by EDATEC. By deploying it at your home or office, you can provide your city with miles of low-power network coverage for billions of devices and earn a new cryptocurrency, HNT.

Highlight

- ◆ Wider coverage, with Semtech SX1302 + SX1250 concentrator
- ◆ High performance, with 580MHz MIPS processor, 128MB or 256MB DDR, 16MB or 32MB Flash
- ◆ Full coverage Network with WiFi and Bluetooth 5.1 with external antenna
- ◆ Managing & diagnosing from Remote Access Dashboard in LAN
- ◆ OTA support enables automatic online upgrades, without any activation or monitoring operation



SPECIFICATIONS

Dimension Unit:mm

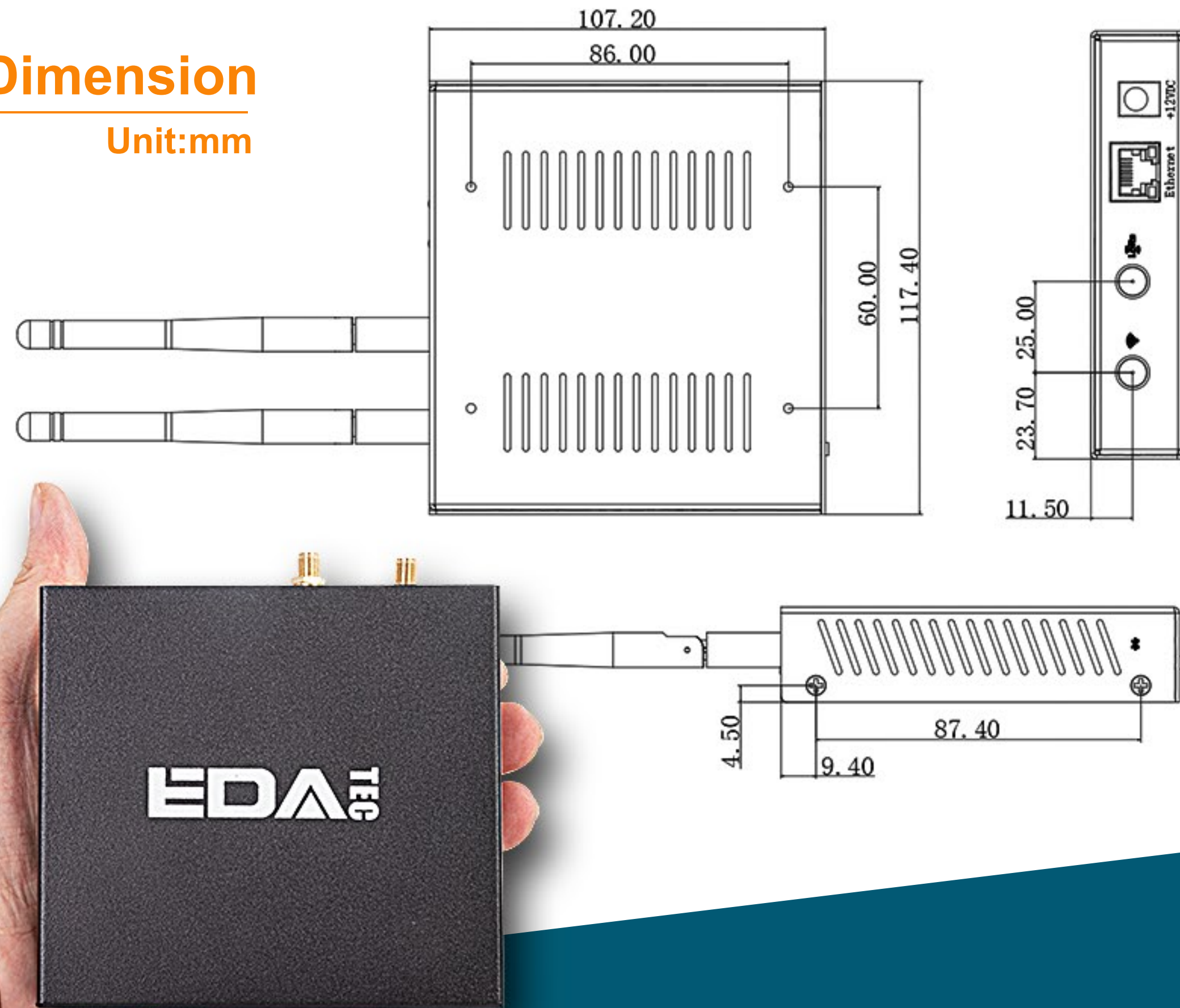

Item	Feature
Processing capability	580MHz MIPS processor 128MB or 256MB DDR
Wired interface	1x 10 / 100M Ethernet
Wireless communication	2.4GHz 802.11 b/g/n wireless LAN Bluetooth 4.2, BLE External Antenna
Storage	16MB or 32MB Flash
LoRa Concentrator	Semtech SX1302 + SX1250
Security	Built-in ATECC608A crypto device
Frequency Band Support	868 ~ 870 MHz (EU868, IN865, RU864) 902 ~ 928 MHz (US915, AU915, KR920, AS923-1/2/3)
Sensitivity	-125dBm @125KHz/SF7 -139dBm @125KHz/SF12
TX Power	Up to 27dBm
Antenna	1x WiFi / BT external Antenna 1x 2.5dBi LoRa Antenna Optional 5.8dBi LoRa Antenna
LED Indicator	1x RGB LED
Button	1x Button for Hotspot Configuration
Power Supply	DC 7.5 V ~ 18V
Operating Temperature	0°C to 50°C
Relative Humidity	0% - 90%
Heat Dissipation	Aluminum enclosure
Dimension	95mm(L) x 95mm(W) x 26mm(H)

ED-IoTHotspot-Pi02

ED-IoTHotspot-Pi02 is a Helium Indoor Light Hotspot designed by EDATEC. By deploying it at your home or office, you can provide your city with miles of low-power network coverage for billions of devices and earn a new cryptocurrency, HNT.

Highlight

- ◆ Semtech SX1303 + SX1250 concentrator with wide range of coverage and low-power consumption
- ◆ High performance, with Quad-core, 1GHz ARM Cortex-A53 64-bit CPU, 512M SDRAM, 8GB storage
- ◆ Full coverage Network with WiFi and Bluetooth 4.2 with external antenna
- ◆ Support managing & diagnosing from Remote Access Dashboard in LAN, self Diagnostic & Repair
- ◆ OTA support enables automatic online upgrades, without any activation or monitoring operation



<https://www.edatec.cn/en/elpc/iothot-pi2.html>

SPECIFICATIONS

Dimension

Unit:mm

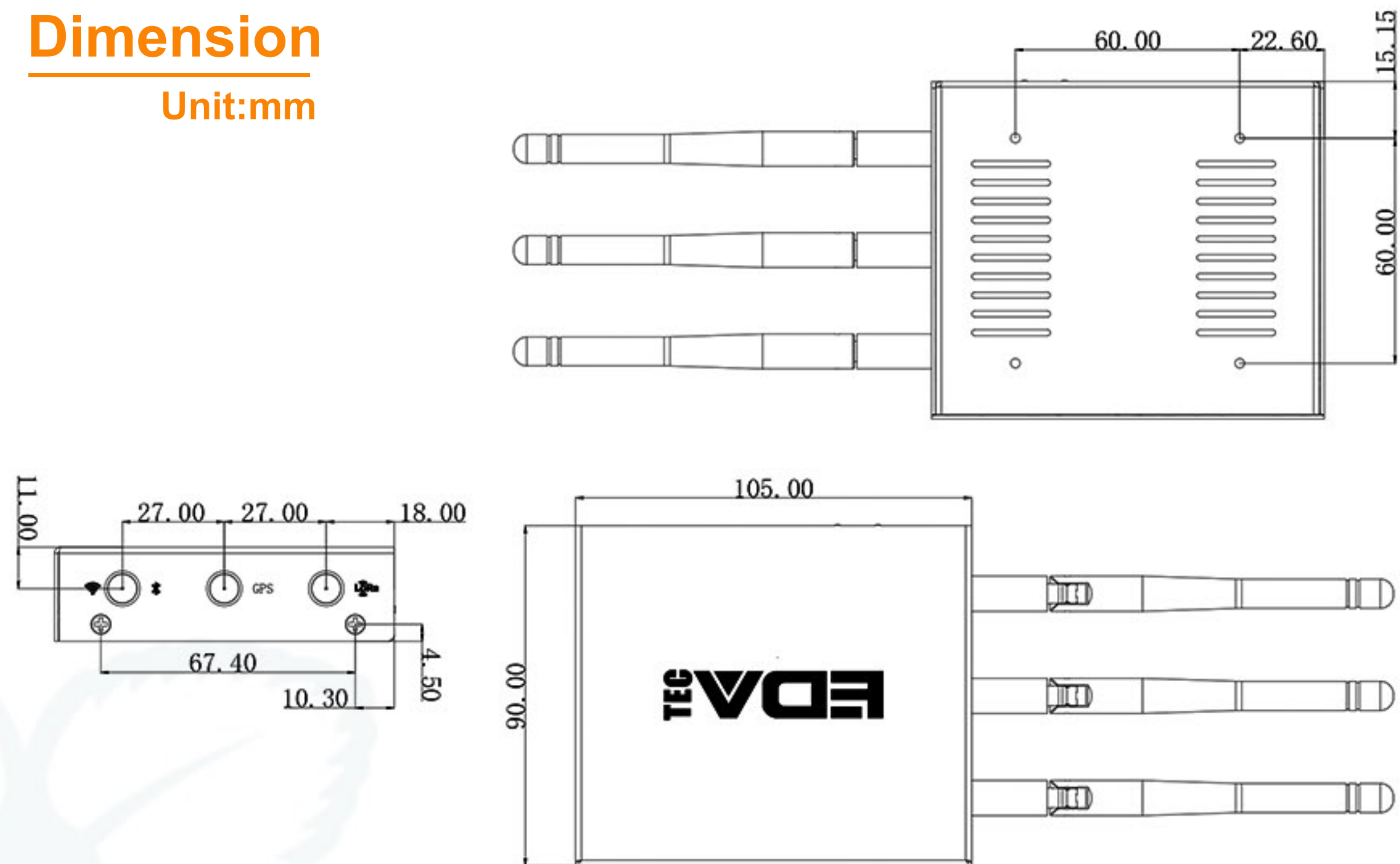

Item	Feature
Raspberry Pi Compatibility	Raspberry Pi Compute Module 1 Raspberry Pi Compute Module 3 Raspberry Pi Compute Module 3 Lite Raspberry Pi Compute Module 3+ 8 GB / 16 GB / 32 GB eMMC flash Raspberry Pi Compute Module 3+ Lite
Connectivity	1 x 10/100M Ethernet 2 x USB2.0 1 x USB Slave for system programming 3 x UARTs(TTL Signal) 1 x RS485 with Lightning Protection
Wireless	1 x WiFi complies with IEEE802.11b/g/n Standard 1 x Bluetooth 4.1 4G /LTE Module by Mini PCI-e connector (Optional) LoRa Concentrator Gateway Module by 24pins DIP connector (Optional)
Storage	1 x microSD card slot On Board 2Kb EEPROM On Board 32Mb serial Flash
System Monitoring	On Board RTC On Board Low Voltage Detector(LVD) 1x high precision temperature sensor
User Interface	1 x Red & 1 x Green LED Indicator 1 x System Reset Button 1 x Custom User Button 1 x Buzzer
Expansion Interface	1 x USB Interface by Mini PCI-e Socket 1 x USB Interface by a 4pins DIP connector 1 x High Speed SPI by 24pins DIP connector 1 x Raspberry Pi Standard 40Pins Connector
Camera & Display	1 x CSI supports the standard CSI cameras 1 x HDMI 1 x DSI supports Raspberry Pi Official Display
Power Supply	7 ~ 18V DC Input by Phenix Connector
Dimensions	160 mm(L) x 120 mm(W) x 20mm(H)
Software Environment	Raspberry Pi Raspbian OS installed

ED-IoTHotspot-Pi4

ED-IoTHotspot-Pi4 is a Helium Indoor Full Hotspot. By deploying it at your home or office, you can provide your city with miles of low-power network coverage for billions of devices and earn a new cryptocurrency, HNT.

Highlight

- ◆ **Wider coverage, with Semtech SX1302 + SX1250 concentrator with wide range and low-power consumption**
- ◆ **High performance, Quad-core, 1.5GHz ARM Cortex-A72 64-bit CPU, 2GB/4GB LPDDR4, 32GB/64GB storage**
- ◆ **Multiple connectivity, Gig-Ethernet, Dual-band WiFi and Bluetooth 5.0 with external antenna**
- ◆ **Multi antenna options, with standard 2.5dBi antenna, optional 8 dBi antenna**
- ◆ **Efficient cooling solution, aluminum enclosure with a heatsink and cooling fan inside**



SPECIFICATIONS

Interface Diagram

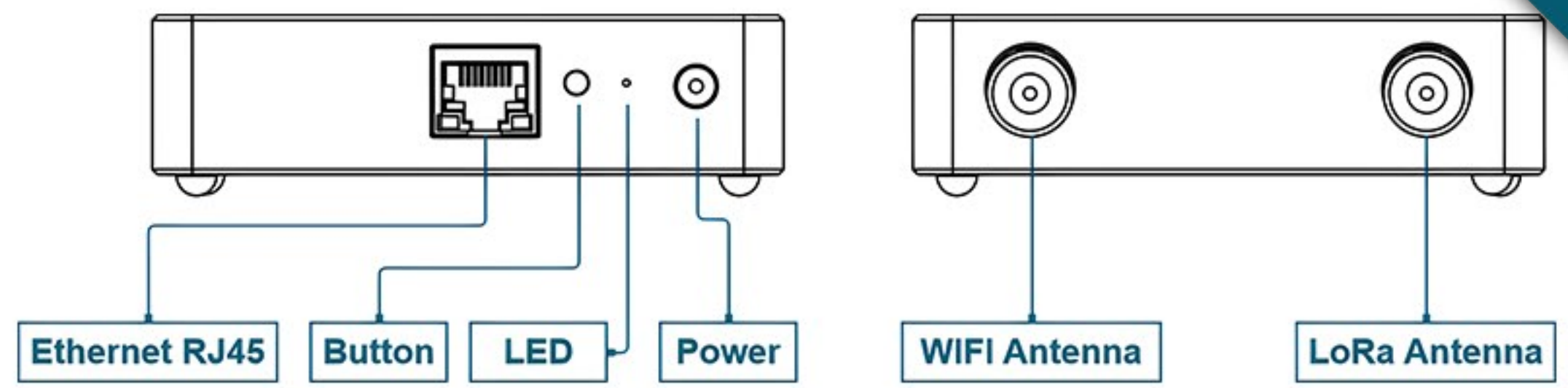

Dimension Unit:mm

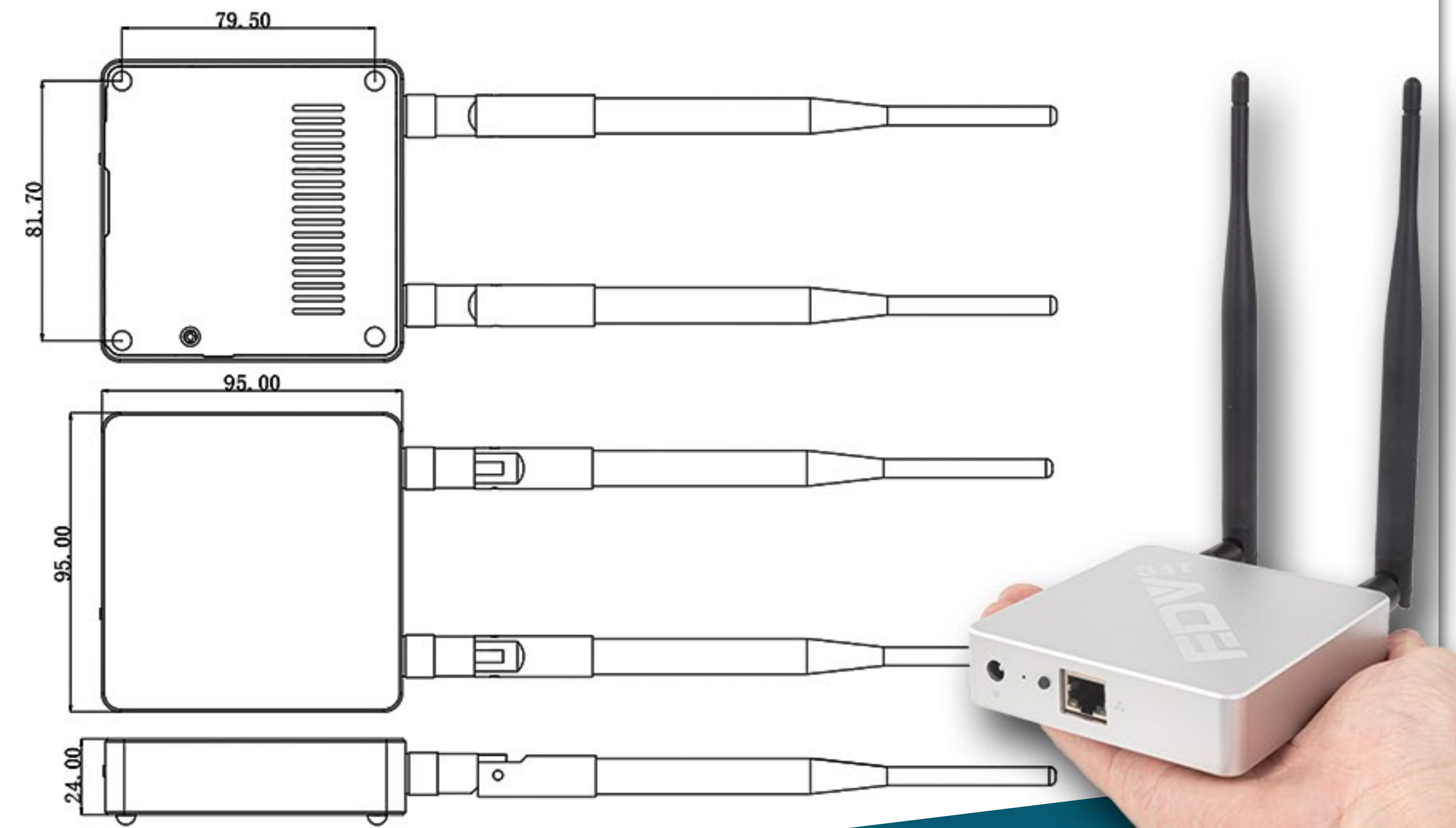

Item	Feature
Processing capability	Quad-core, 1.5GHz ARM Cortex-A72 64-bit CPU, 2GB/4GB LPDDR4, 32GB/64GB storage
Connectivity	Gig-Ethernet, Dual-band WiFi and Bluetooth 5.0 with external antenna
Frequency Plans	model 868 MHz (EU868, RU864) model 915 MHz (US915, AS923-1/2/3, AU915)
Multi Antenna Options	Standard 2.5dBi antenna Optional 8 dBi antenna
LoRa Concentrator	Semtech SX1302 + SX1250 concentrator with wide range and low-power consumption
Automatic Online Upgrades	Automatic OTA upgrades, without manual operation
Cooling Solution	Aluminum enclosure with a heatsink and cooling fan inside, ensuring long-term and stable operation
Qualification	CE/FCC

CM4 IO Computer

CM4 IO Computer is a computer based on Raspberry Pi Compute Module IO Board & Compute Module 4 , it provides excellent cooling performance, RTC and other computer interface like HDMI,USB and ethernet, one click button to control system on/off like a normal computer.

Highlight

- ◆ 2 x full-size HDMI 2.0 connectors
- ◆ 2 x USB 2.0 connectors
- ◆ Gigabit Ethernet RJ45 with PoE support
- ◆ MicroSD card socket for Compute Module 4 Lite variants
- ◆ PCIe Gen 2 x1 socket
- ◆ Standard fan connector
- ◆ Real-time clock with battery socket



SPECIFICATIONS

Dimension

Unit:mm

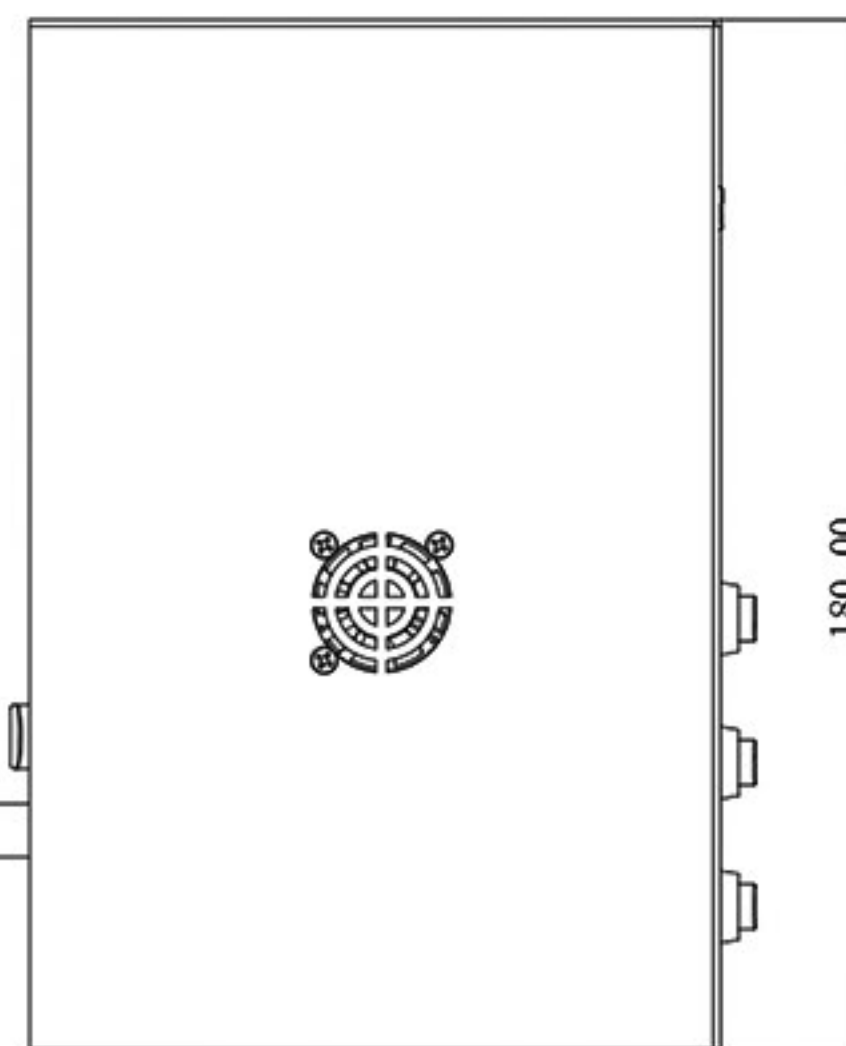
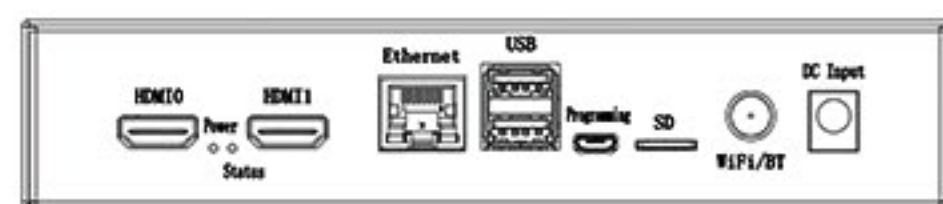
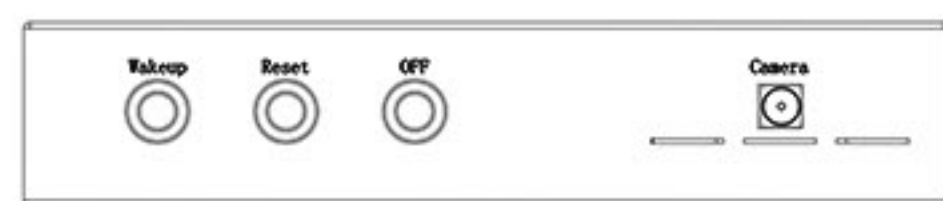
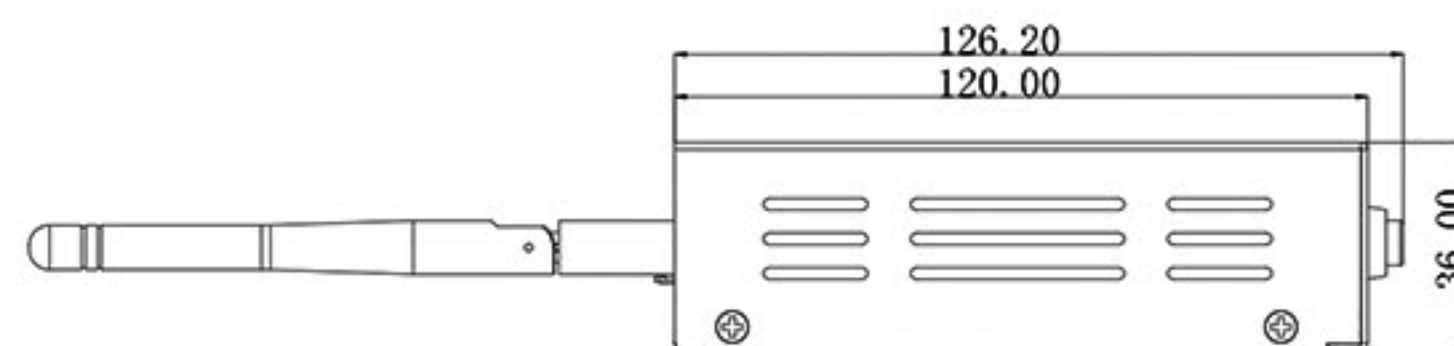

Category	Feature
Processing capability	Broadcom BCM2711 4 and Cortex A72 1.5GHz (ARM v8) 64-bit CPU Supports H.265 (HEVC) (up to 4Kp60 decoding) and H.264 (up to 1080p60 decoding, 1080p30 encoding) OpenGL ES 3.0 graphics Storage 1GB/2GB/4GB/8GB LPDDR4-3200 SDRAM (optional) Lite 0GB/8GB/16GB/32GB eMMC (optional)
Connectivity	1 x 10/100M/1000 Ethernet (with official PoE HAT) supports POE power supply 2 x USB2.0 1 x Micro USB Slave(system programming)
Wireless	1 x 2.4G/5.8G WiFi compatible with IEEE 802.11 b/g/n/ac Standard 1 x Bluetooth 5.0 BLE WiFi/BLE external antenna
Storage	1 x microSD card slot(Not functional for CM4 EMMC version)
Control	1 x system on/off button 1 x 12V/50mA PWM controlled fan 1 x RTC with backup battery 1 x RED LED for power indication 1 x Green LED for system working status indication
Expansion Interface	PCIe 1x Gen2 Mini-PCIe interface 1 x Raspberry Pi Standard 40pins connector 1 x 4pin DIP header for PoE HAT
Camera & Display	2 x CSI supports the standard official Raspberry Pi 5M & 8M HQ camera module 2 x DSI supports Raspberry Pi official display 2 x HDMI
Power In	+12V DC @2A
Operating temperature	-25~50°C
Dimension	171.5(L) x 109.5(W) x 28.5(H) mm
Software Environment	Raspberry Pi Raspbian OS installed

Dimension

Unit:mm

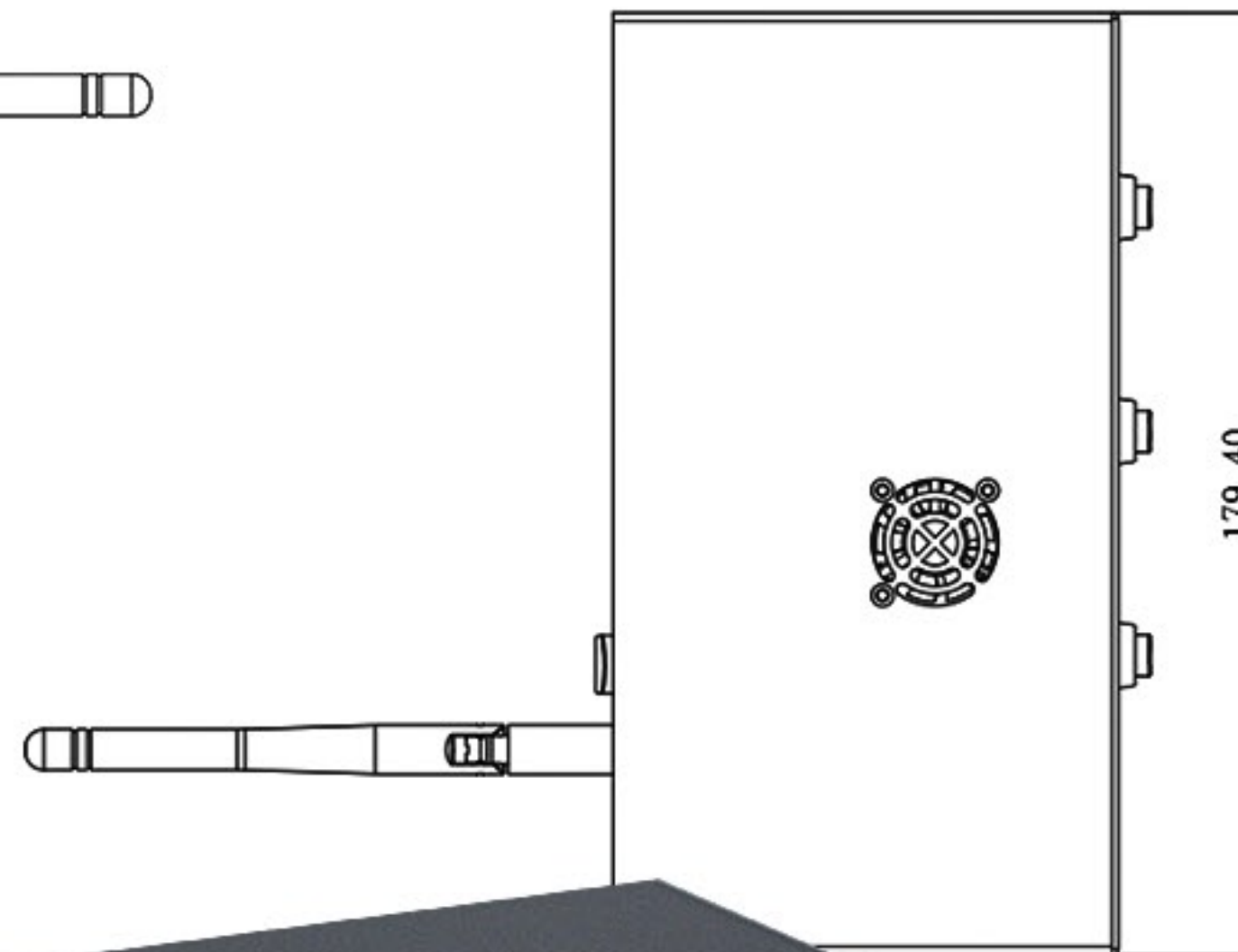
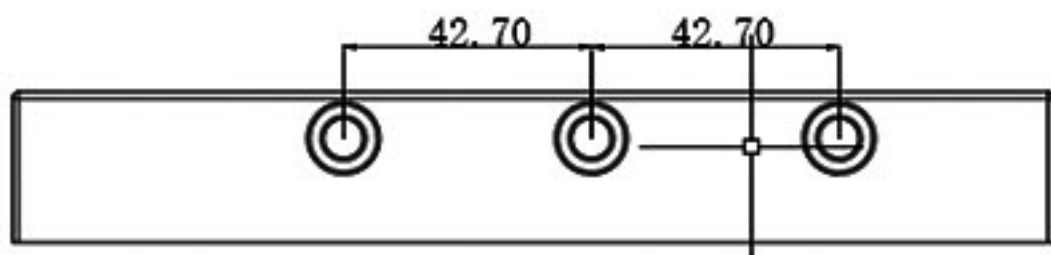
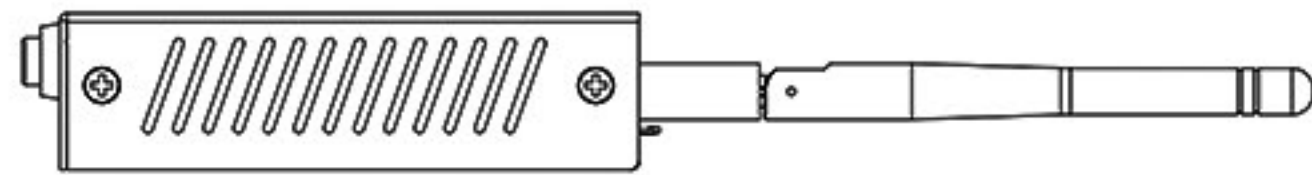
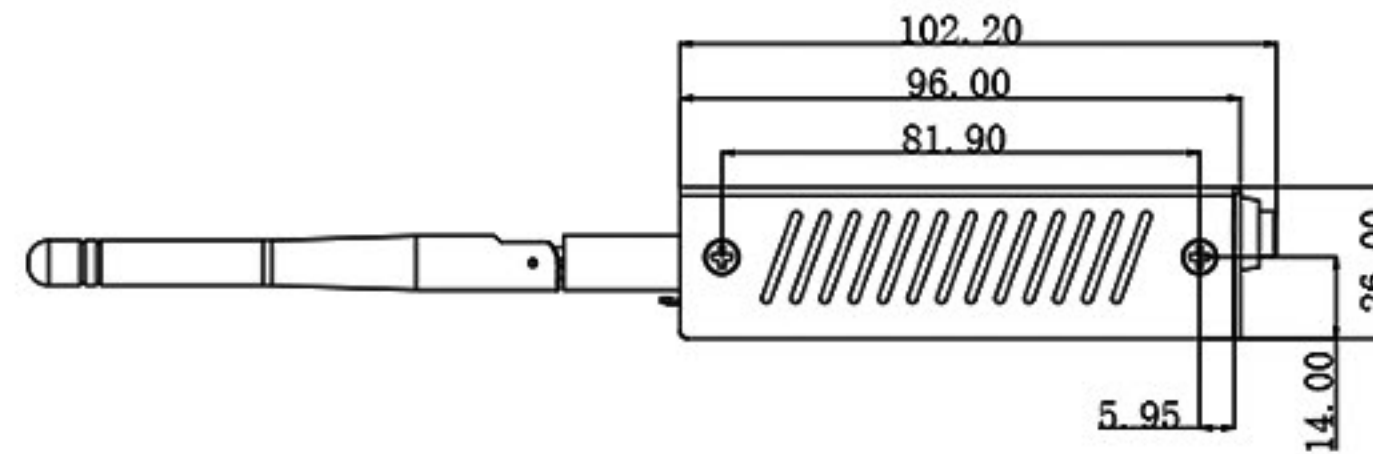

CM4 IO Smart Case

CM4 IO Smart Case is to convert Raspberry Pi Compute IO Board into a real industrial computer.

Item	Feature
One-Click Switch	One-click switch is to control the system power on and shut off by GPIO3 on 40pin connector & the software running on Compute Module 4.
Hardware Protection	The case perfectly fits the mechanicals of the Raspberry Pi Compute Module 4 IO Board, and all interfaces are led out of the enclosure. The metal case provides excellent shielding and protection for Compute Module 4 & IO Board.
Fix Compute Module 4	The four nuts at the bottom of the case can help to fix the Compute Module 4 on IO board & case reliably. There are four 1.5mm height black nylon washers to support Compute Module 4 on the four corners of PCB. This feature prevents PCB deformation and circuit damage when the Compute Module 4 is screwed on the IO board without something to support.
Cooling Compute Module 4	A 12V/60mA silent fan is installed directly over the Compute Module 4, which is isolated from the case by four silicone washers, these silicone washers greatly reduce the noise magnification by the case. The fan can reduce the CPU temperature by maximal 20°C and heat generated by the whole system is dissipated by the fan through the slots at the sides of the case.
External Antenna	Raspberry Pi's Official certified 2.4G/5.8GHz WiFi/Bluetooth Antenna installed on the case.
Battery	Offer Philips CR2032 Eco-friendly to enable RTC function.
Dimension	171.5(L) x 109.5(W) x 28.5(H) mm
Weight	450g

<https://www.edatec.cn/en/ac/cm4-io-case.html>

ED-GW1302S/1303S LoRaWAN Gateway Module

ED-GW1302S/ED-GW1303S module is a new generation of LoRaWAN gateway module in mini-PCle form-factor with SPI interfaces based on Semtech® SX1302/1303 and SX1250. It features extremely low power consumption, outstanding performance with CE, FCC certified.

Highlight

- ◆ Mini PCIe form factor with SPI interfaces
- ◆ Powered by Semtech® SX1302/1303 baseband processor
- ◆ Ultra-low operating temperature without additional heat dissipation needed
- ◆ High sensitivity with Semtech® SX1250TX/RX front-end; TX power up to 27 dBm @3.3V
- ◆ Supports global license-free frequency band including EU868,CN470, US915, AS923, AU915,KR920 and IN865
- ◆ Certified with CE, FCC



[1302S] <https://www.edatec.cn/en/ext/lora1302.html>

[1303S] <https://www.edatec.cn/en/ext/lora1303.html>

CM4 Cooler

CM4 Cooler is a heatsink specially designed for Raspberry Pi Compute Module 4, which ensure Compute Module 4 to work reliably.

Highlight

- ◆ Lower the temperature of CM4 module by up to 20°C
- ◆ Heat dissipation for CPU, PMU & Wireless module
- ◆ 1.5mm or 3mm height nylon washer to support CM4
- ◆ Dimension: 55*40*13.5mm
- ◆ Weight: 40g

Dimension Unit:mm

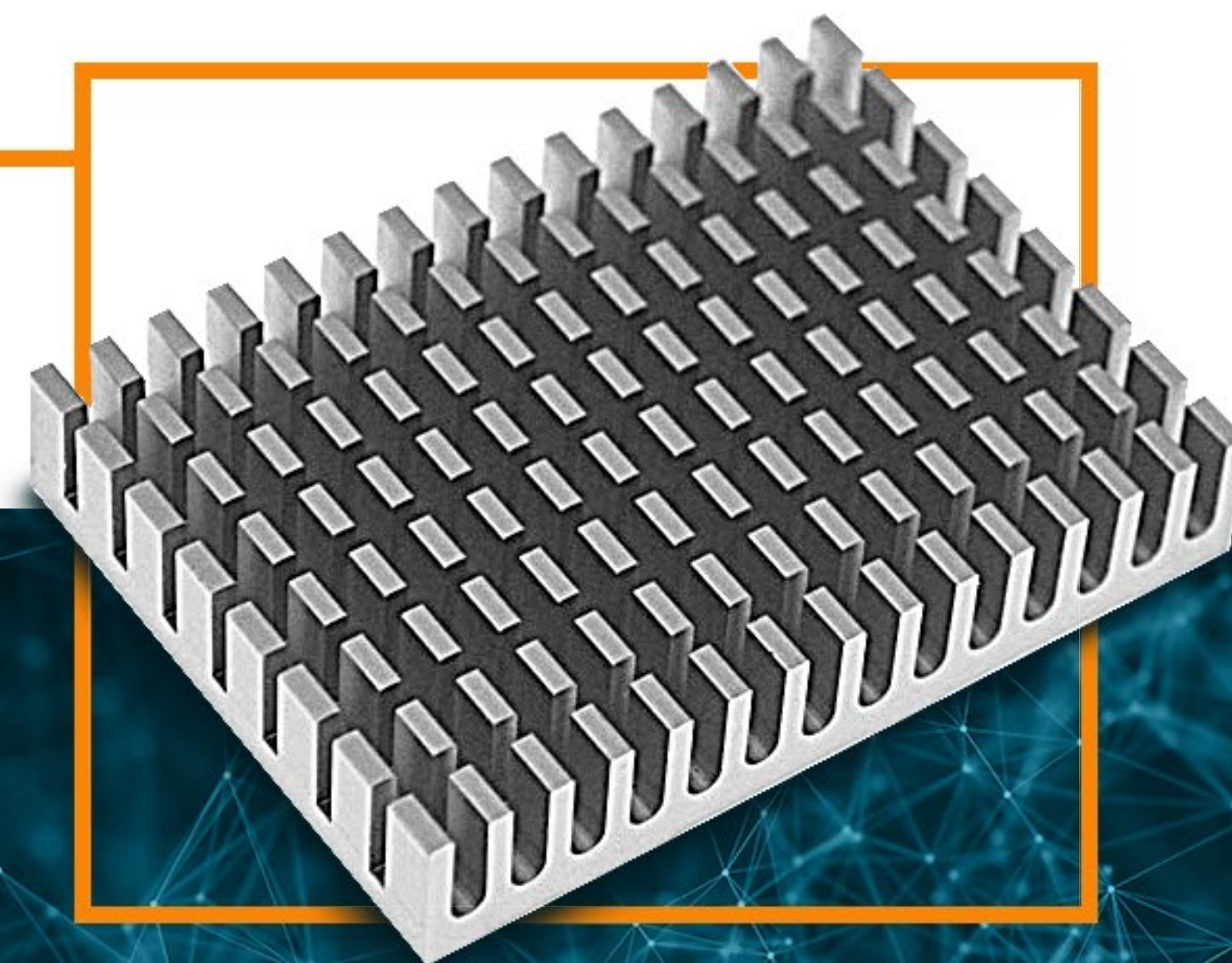
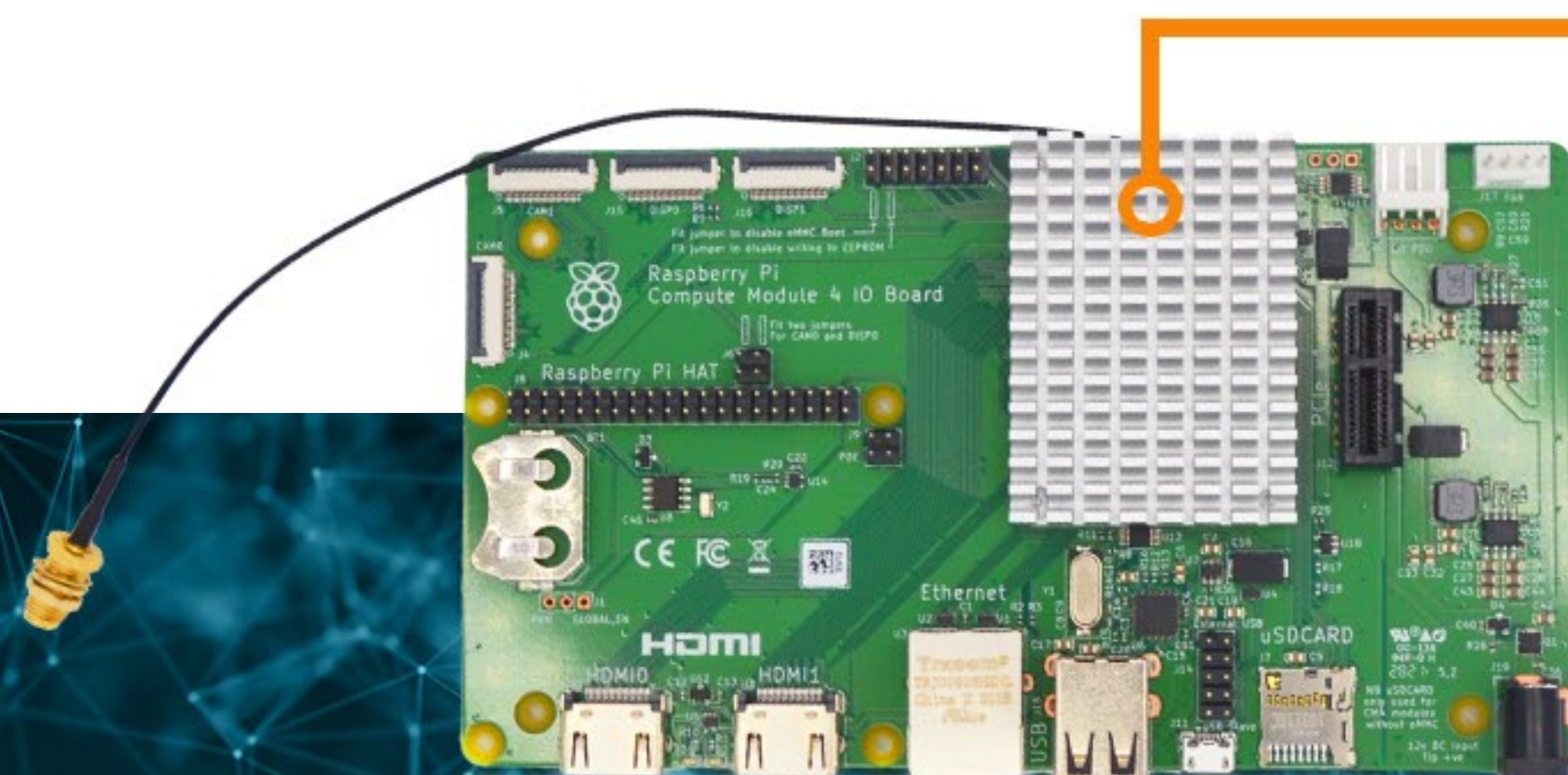
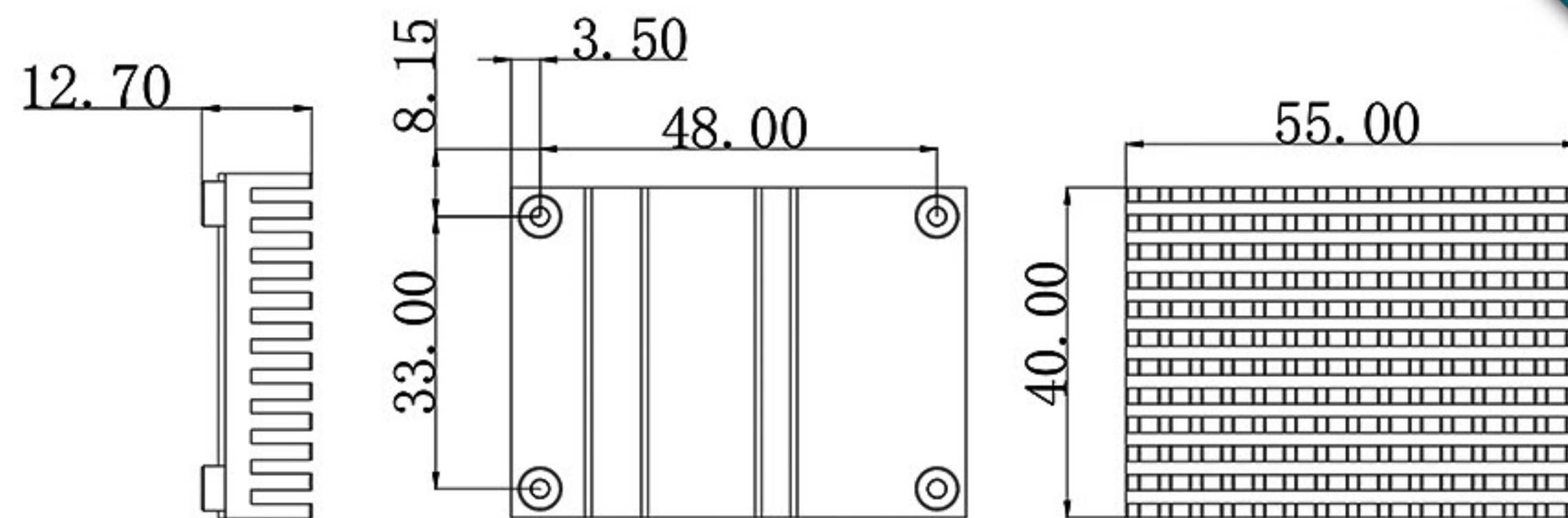

EDATEC has developed our own automated programming tools to provide customers with fast and efficient CM4 mass programming services.

Our professional production team and strict management system provide reliable guarantee for mass programming yield and delivery time.

Method 2 : One-stop service

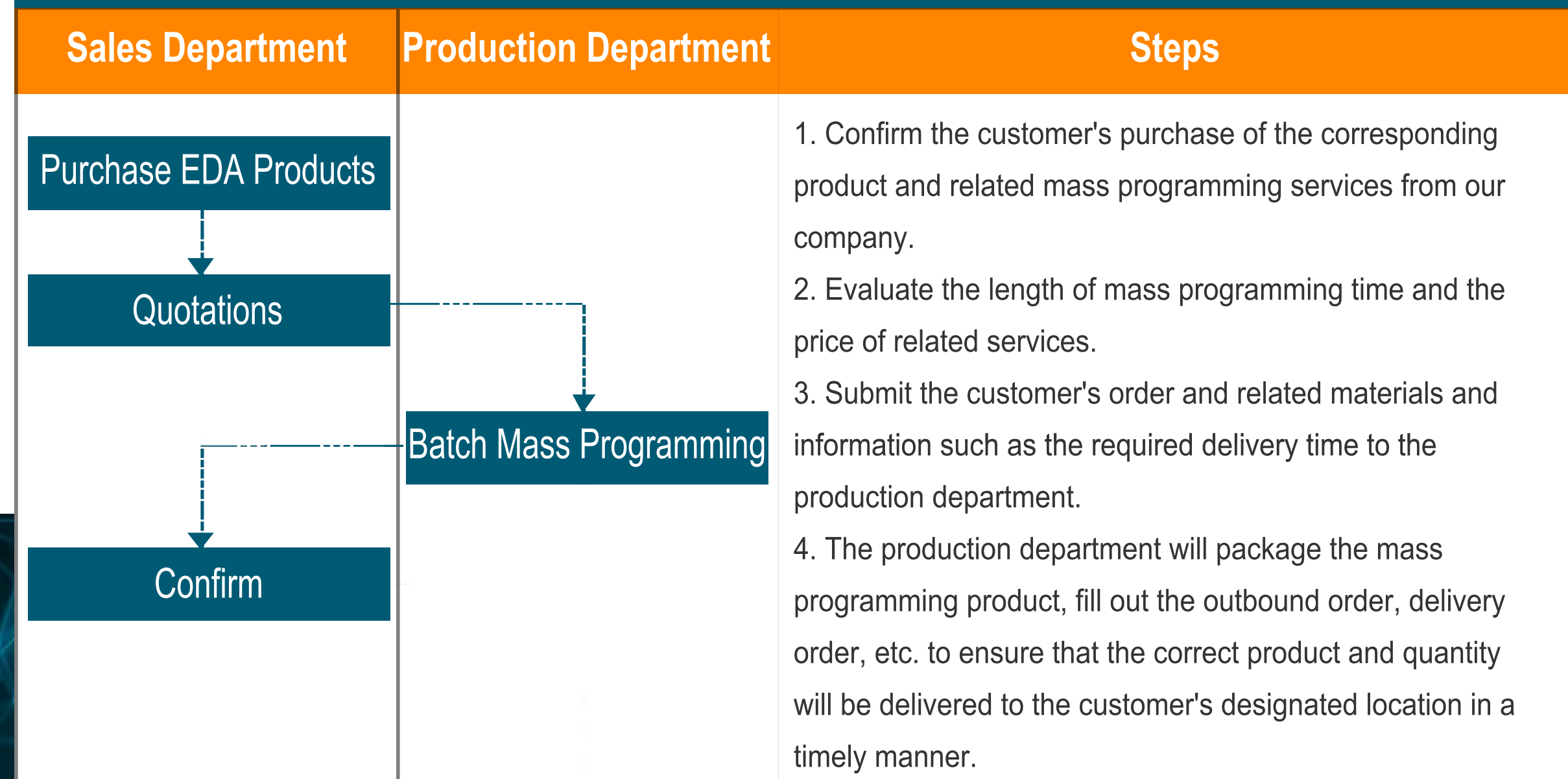

Method 1 : Mass Programming Service

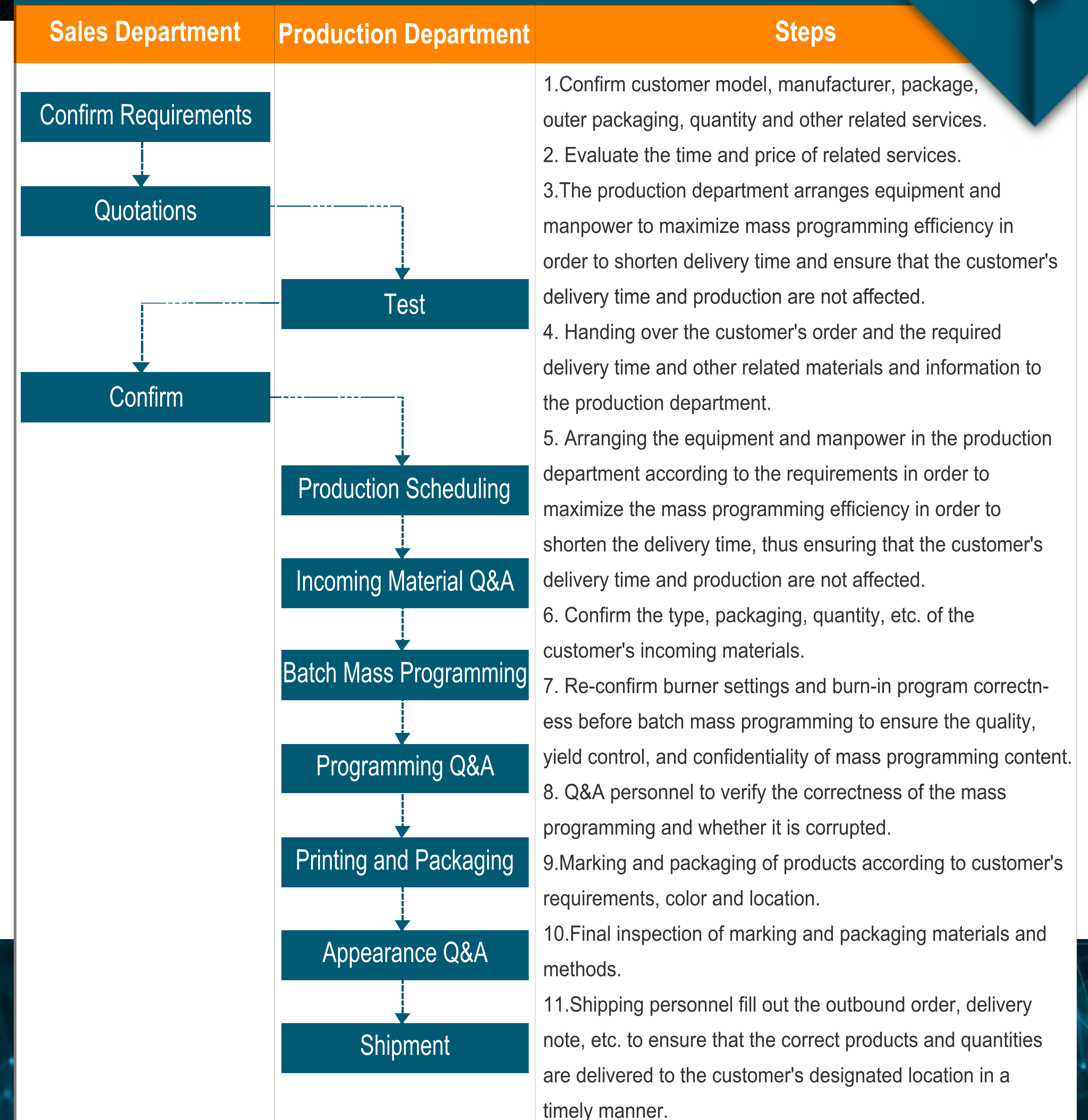

CONTACT INFORMATION

TEL

CN: Iris Zhou +86-18217351262

US: Randall Restle +1 859-653-0800

US: David Esto +1 843-737-1142

Email

support@edatec.cn

Address

Building 24, No. 1661,
Jialuo Road,
Jiading District, Shanghai.

Website

<https://www.edatec.cn/en/>

