

Plastic Film Capacitor

Products Catalog

Electronic Equipment Use

AC Motor Use

Automotive, Industrial and Infrastructure Use



Guidelines and precautions regarding the technical information and use of our products described in this online catalog.

- If you want to use our products described in this online catalog for applications requiring special qualities or reliability, or for applications where the failure or malfunction of the products may directly jeopardize human life or potentially cause personal injury (e.g. aircraft and aerospace equipment, traffic and transportation equipment, combustion equipment, medical equipment, accident prevention, anti-crime equipment, and/or safety equipment), it is necessary to verify whether the specifications of our products fit to such applications. Please ensure that you will ask and check with our inquiry desk as to whether the specifications of our products fit to such applications use before you use our products.
- The quality and performance of our products as described in this online catalog only apply to our products when used in isolation. Therefore, please ensure you evaluate and verify our products under the specific circumstances in which our products are assembled in your own products and in which our products will actually be used.
- If you use our products in equipment that requires a high degree of reliability, regardless of the application, it is recommended that you set up protection circuits and redundancy circuits in order to ensure safety of your equipment.
- The products and product specifications described in this online catalog are subject to change for improvement without prior notice. Therefore, please be sure to request and confirm the latest product specifications which explain the specifications of our products in detail, before you finalize the design of your applications, purchase, or use our products.
- The technical information in this online catalog provides examples of our products' typical operations and application circuits. We do not guarantee the non-infringement of third party's intellectual property rights and we do not grant any license, right, or interest in our intellectual property.
- If any of our products, product specifications and/or technical information in this online catalog is to be exported or provided to non-residents, the laws and regulations of the exporting country, especially with regard to security and export control, shall be observed.

<Regarding the Certificate of Compliance with the EU RoHS Directive/REACH Regulations>

- The switchover date for compliance with the RoHS Directive/REACH Regulations varies depending on the part number or series of our products.
- When you use the inventory of our products for which it is unclear whether those products are compliant with the RoHS Directive/REACH Regulation, please select "Sales Inquiry" in the website inquiry form and contact us.

We do not take any responsibility for the use of our products outside the scope of the specifications, descriptions, guidelines and precautions described in this online catalog.

PRECAUTION AND WARNING

- Please consult us in case that demand the specification of our company without fail and do the confirmation of the use condition and that exceeds the entry value and be indistinct when you use it.
- The film capacitors contain a film based dielectric which may be flammable under certain operating conditions. When in use, they can either emit smoke and/or ignite should the product be defective. It is recommended covering the surrounding resin with flame-resistant materials or case as needed particularly.
- In the event of troubles of other parts on the circuit such as shortening and opening, provide with proper means for preventing excessive voltage, current or temperature exceeding the rating from being applied to the film capacitor.
- Prior to use, please make sure that failure of the film capacitors does not have any negative effects on other surrounding electronic circuit components and devices that would possibly cause damage. Proper safety measures should be taken using fail-safe protective circuit designs to help prevent other devices of becoming unsafe.

Example:

- a. State in which basic performance of automobiles (run, turn and stop)
 - b. False operations
 - c. Smoke emission/ignitions
- The Film Capacitor listed in this catalog(except for automotive series) are designed and manufactured specifically for general electronic devices, including audio-video equipment, home appliance, office equipment and data communication equipment etc.. Accordingly, it is strongly recommended that the user contact us in advance if the parts are to be used for the following devices(items 1 -12), which require having advanced security measures. The capacitor for automotive can be used for automobiles such as xEV.
 - (1) Transport Equipment (motor vehicles, airplanes, trains, ships, traffic signal controllers)
 - (2) Medical Equipment (life-support equipment, pacemakers for the heart, dialysis controllers)
 - (3) Aircraft Equipment, Aerospace Equipment (airplanes, artificial satellites, rockets, etc.)
 - (4) Submarine Equipment (submarine repeating equipment, etc.)
 - (5) Generation Control Equipment (equipment for atomic/hydraulic/heat power plants)
 - (6) Information Processing Equipment (large scale computer system)
 - (7) Electric Heating Appliance, Burning Apparatus
 - (8) Rotary Motion Equipment
 - (9) Security Systems
 - (10) Robots
 - (11) Lighting Equipment
 - (12) And any similar types of equipment
 - If used in a specific appliance that requires an extremely high reliability directly relating with any life-supporting equipment like electronic aviation controllers, automotive driving controllers and engine controllers, please consult us and use within the conditions designated in the specification. However the chip type capacitor should not be used in these appliances.

Note:

1. Technical information in this catalog is intended to convey examples of typical performances and/or applications, and is not intended to convey patents rights, if any.
2. For the products, which are controlled items subject to the Foreign Exchange and Foreign Trade Control Law, the export permission according to the Law is necessary.
3. Note of ozone depleting substances of class1 (ODS) under the Montreal Protocol is used in manufacturing process of Device Solutions Business Division, Panasonic Corporation.

⚠ Guidelines and precautions (Common)

(Target product : ECQE, ECWF, ECWH, ECQU, ECHU, ECWU, ECPU)

1. Operating voltage

For the film capacitor varies the maximum applicable voltage depending on the applied voltage waveform, current waveform, frequency, ambient temperature (capacitor surface temperature), capacitance value, etc. Use within the specified values by checking the voltage waveform, current waveform, and frequency applied to both ends of the capacitor prior to use. (In the case of high frequency, the permissible voltage varies with the type of the capacitor. For details please see the relevant specifications.)

1.1 Rated voltage (Note 1)

- The rated voltage refers to the maximum voltage that can be applied continuously within the category temperature range. If used beyond the rating, it may induce insulation breakdown of the film and cause short circuit. The product lifetime about the maximum rated condition depends on the kind of the capacitor.
- In a metalized capacitor, which has a self-healing action, short circuit or other failure may not occur immediately after application of a voltage over the rated voltage, but the insulation resistance is lowered, and it may lead to smoke or fire depending on the circuit conditions.
- A noise suppression capacitor (AC rated voltage) should not be used at high frequency circuit. Smoke and ignition may be caused by conditions for use.
- The rated voltage of the capacitor for electronic appliance is usually indicated in the DC voltage except for special purposes.

1.2 Derating of rated voltage where operating temperature is high

In film capacitors, the usable upper limit temperature (the capacitor surface temperature) is determined by the kind of dielectric materials.

When used beyond the rated upper limit temperature (usable upper limit temperature), it is necessary to voltage derate the in certain types (models), while other types (models) cannot be used beyond the rated upper limit temperature. Be sure to confirm the type of capacitors before using, and when using beyond the rated upper limit temperature, be sure to reduce the voltage and make sure the capacitor surface temperature is within the usable upper limit temperature as below. When using at high frequency, however, since the capacitor itself has its own temperature rise, and hence the following derating ratio cannot be applied.

<Rated upper limit temperature, Upper category temperature, and derating ratio of upper category temperature by types in DC use> (Example)

Dielectric	Type	Rated upper limit temperature	Upper category temperature	Rated voltage by the temperature beyond Rated upper limit temperature
Polyester(PET)	ECQE(F) ECQE(B) ECQE(T)	85°C	105°C	1.25%/°C
Polypropylene (PP)	ECWF(A) rated voltage DC250V ECWF(L) ECWH(A) ECWH(C)	105°C	105°C	No need derating of rated voltage
	ECWF(A) rated voltage DC450V ECWF(A) rated voltage DC630V ECWH(V)	85°C	105°C	1.25%/°C
	ECWFE rated voltage DC450V ECWFD rated voltage DC630V ECWFE rated voltage DC630V	85°C	105°C	1.0%/°C
	ECWFD rated voltage DC450V	85°C	110°C	0.62%/°C
	ECWFG rated voltage DC630V	85°C	110°C	1.0%/°C
	polyethylene naphthalate(PPS)	ECWU(X)	105°C	105°C
ECWU(C)		85°C	125°C	1.25%/°C
ECWU(V16)		85°C	85°C	No need derating of rated voltage
polyphenylene sulfide(PPS)	ECHU(X) rated voltage DC16V ECHU(X) rated voltage DC50V (capacitance 0.0001μF~0.10μF)	125°C	125°C	No need derating of rated voltage
	ECHU(X) rated voltage DC50V (capacitance 0.12μF~0.22μF)	105°C	125°C	1.25%/°C
	ECHU(C)	105°C	105°C	No need derating of rated voltage
Acrylic resin	ECPU(A)	85°C	85°C	No need derating of rated voltage

- The AC rated voltage items are unnecessary for voltage derating by the temperature.
 Rated upper limit temperature : The upper limit temperature which can't reduce the voltage and can use continuously. (including own temperature rise)
 Upper category temperature : The upper limit temperature which can reduce the voltage and use continuously. (including own temperature rise)

● **(Example)** Derating of rated voltage to operating temperature. Rated upper limit temperature 85°C, Upper category temperature 105°C, Derating of rated voltage to which is 1.25 %/°C at more than 85 °C

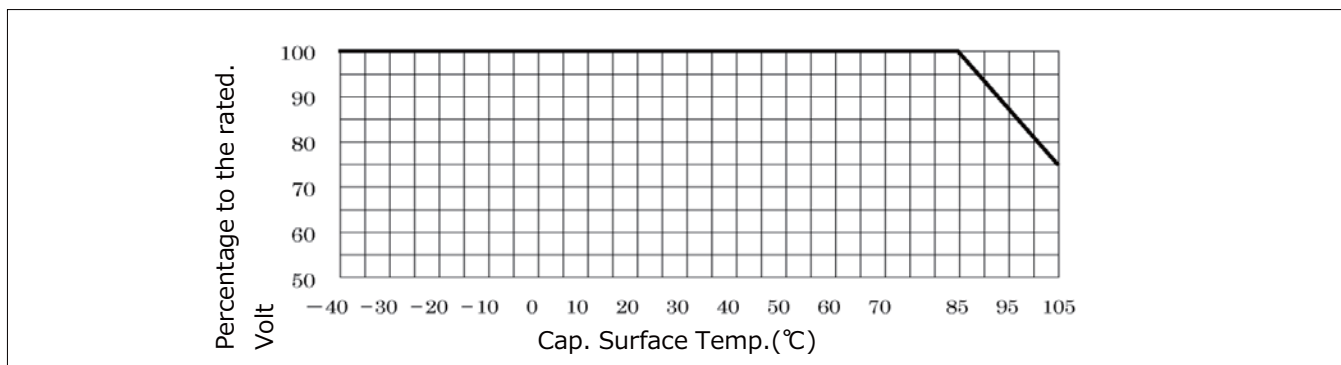

1.3 Permissible voltage (R.M.S) in current corresponding to DC Rated Voltage

- A noise suppression capacitor (AC rated voltage) should be used at the primary side power supplies. The design which premised on use by 50Hz or 60Hz sine wave.
- In case of applying voltage in alternating current (50Hz or 60Hz sine wave) to a capacitor, permissible voltage(R.M.S).The capacitor of DC rating should not be used at the primary side power supplies.

1.4 Derating of rated voltage when using at high frequency

When using at high frequency, there is a risk of thermal runaway (smoke, fire) due to self heat generation in the capacitor. Derate the operating voltage according to the example below.

For use at high frequency, we recommend ECHU(X)/(C), ECWF(A)/(L), and ECWH(A)/(C)/(V) types.

<Derating example of operating voltage>

Capacitor used : ECWF2154JA (250 VDC, 0.15 μF)

Operating frequency : 40 kHz (sine wave)

Permissible current (entry the value from specification) : 40 kHz, 2.0 Arms

$$V = \frac{I}{2\pi fC} = \frac{2.0}{2 \times 3.14 \times 40 \times 10^3 \times 0.15 \times 10^{-6}} = 53 \text{ Vrms}$$

Therefore, the operating voltage at sine wave 40 kHz is lower than to 53 Vrms (derating ratio 58%), as compared with AC permitted voltage of 125 Vrms at commercial frequency.

(It is necessary to derate until the self heating temperature rise of the capacitor is below the specified value.)

Notes

- (1) Use the peak value (Vo-p) of the Pulse voltage applied between the both terminals of the capacitor within the DC rated voltage.
- (2) When using at high frequency, it may lead to breakdown due to withstand voltage deterioration by self heat generation. Therefore, measure the self heating temperature rise value of the capacitor, and make sure it is within the specified.
- (3) Protection for safety should be required in the case of the voltage over the rated voltage (permitted voltage) may be applied to the capacitor due to abnormal action such as trouble elsewhere in the circuit.

2. Permitted current

Film capacitors are low in internal impedance, and hence a very large current may flow depending on the circuit. In particular, when turning power switch on and off, make sure a very high pulse current may flow.

When a current exceeding the permissible range flows into capacitor, this can cause the capacitance value to deteriorate or an open circuit condition, temperature rise occurs due to self heat generation, this cause can deterioration of withstand voltage and result in short circuit, possibly leading to smoke or fire.

In the application, make sure current is within permissible current or self heating temperature is within permissible self heating temperature rise limit shown on each delivery specifications.

2.1 Permissible current

The permissible current must be considered by dividing into pulse current (peak current) and continuous current (rms current) depending on the breakdown mode, and when using, therefore, make sure the both currents are within the permissible values.

2.2 Permissible current to operating frequency

The film capacitor varies in the frequency characteristic of the dissipation factor ($\tan\delta$) depending on the dissipation factor, and hence the permissible rms current for operating frequency differs depending on the capacitor type. In particular, when operating at high frequency, the dissipation factor ($\tan\delta$) increases, and when using over the permissible current, it may include the thermal runaway, possibly leading to smoke or fire. Shown below are typical examples of permissible current by frequency (rms value) of the ECQE(F) type using polyester film and ECWF(A) type using polypropylene film. For detail inquire us by presenting the operating conditions, or make sure the own temperature rise of the capacitor and the capacitor surface temperature are within the permissible range in the worst operating conditions.

2.3 The capacitance and the permissible currents

The permissible rms current varies with the capacitance value. The permissible current (rms) values by the frequencies and by the capacitance of representative types are shown below. In actual use, inquire us for detail by measuring the voltage and current waveforms, ambient temperature, and own temperature rise.

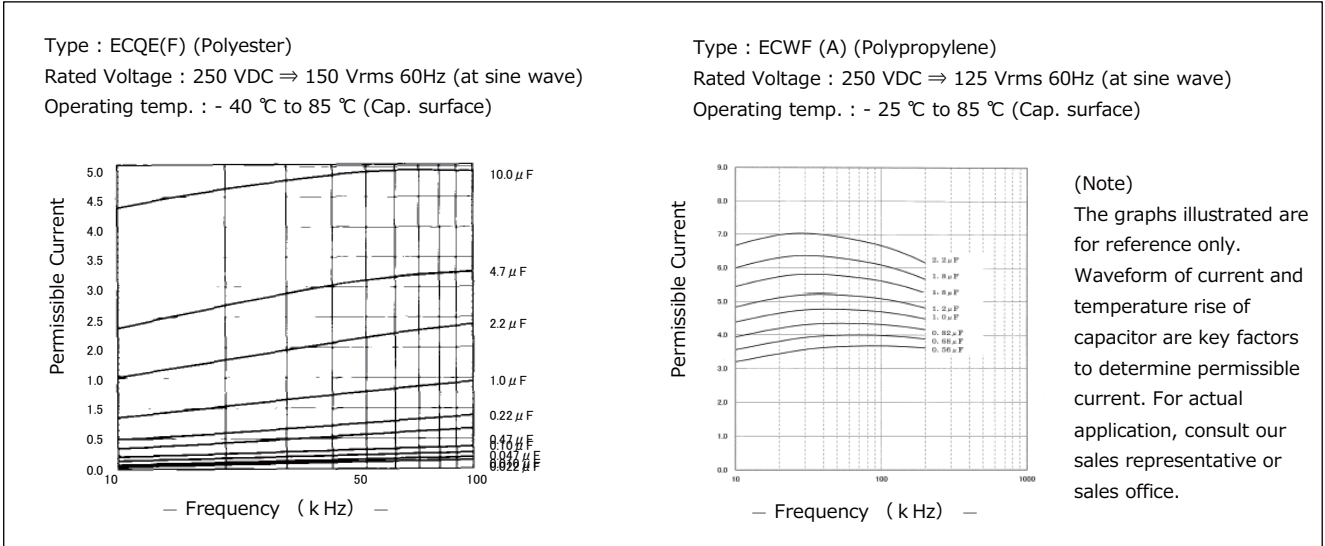

2.4 Permissible current to pulse current

- When used in switching circuits or snubber circuits a momentary high current pulse may cause local heat generation. This causing the capacitance value to deteriorate or an open circuit condition. Local heat generation may also induce smoke or fire. The pulse permissible current (10000 times) isobtained by the product of dV/dt (V/μs) value that is entering to the specification and capacitance (μF).
- The dV/dt (V/μs) value of a film capacitor is determined by the element structure, and in the metalized type, in particular, the internal evaporated electrode and external takeout electrode are connected by metalized contact (metal spraying), and hence due caution is needed because the upper limit of dV/dt value is low.
- The dV/dt values corresponding to rated voltage and capacitance value of representative types are shown in page 6. When used in a high current pulse circuit, check the pulse permissible current (Ao-p).
- Please contact with us, If pulses are applied more than 10,000 times.

<How to determine pulse permissible current>

- When voltage V(V) is applied to capacitor C (F for farad), the electric charge Q(C) is expressed in formula ①.

$$Q=C.V.....①$$

- The charging current I(A)flow in the capacitor at this time is expressed in formula ②.

$$I=dQ/dt.....②$$

- Differentiating both sides of formula ① by timet and putting into formula ② yields formula ③.

$$dQ/dt=C.dV/dt$$

$$I=C.dV/dt③$$

- Therefore, the pulse current is determined as theproduct of the capacitance value C (μF) andvoltage change dV/dt per μs.

product of the capacitance value C (μF) and voltage change dV/dt per μs.

(Example) In the case of ECQE4224KF (permissible dV/dt)

Rated voltage : 400VDC,
 Capacitance : 0.22μF,
 permissible dV/dt value : 37

pulse permissible current : 0.22 (μF)×37≐8 Ao-p

(however, number of repetitions is 10,000 times or less), that is, momentary pulse current can be used up to 8 Ao-p.

Make sure the rms current is within the permissible value.

[ECQE (F) Permissible dV/dt value<within 10,000pulses>]

Unit : V/μs

(Cap. :μ F)	Type			
	ECQE(F) 100VDC	ECQE(F) 250VDC	ECQE(F) 400VDC	ECQE(F) 630VDC
103 (0.010)			131	273
123 (0.012)				
153 (0.015)				
183 (0.018)				
223 (0.022)				
273 (0.027)				
333 (0.033)				
393 (0.039)				
473 (0.047)				
563 (0.056)				
683 (0.068)				
823 (0.082)				
104 (0.10)				
124 (0.12)				
154 (0.15)				
184 (0.18)				
224 (0.22)				
274 (0.27)				
334 (0.33)				
394 (0.39)				
474 (0.47)				
564 (0.56)				
684 (0.68)				
824 (0.82)				
105 (1.0)				
125 (1.2)				
155 (1.5)				
185 (1.8)				
225 (2.2)				
275 (2.7)				
335 (3.3)				
395 (3.9)				
475 (4.7)				
565 (5.6)				
685 (6.8)				
825 (8.2)				
106 (10.0)				
	22	18	22	
	*(10.0P)		*(22.5P)	
	11	*(15.0P)	18	48
			10	*(27.5P)
			*(22.5P)	
		6	8	
	*(27.5P)			
	*(22.5P)			

⚠ Caution!

Protective means for safety should be provided in case the pulse and rms current may exceed the

* Asterisk denotes the lead pitch.

The value of dV/dt is mainly determined by the lead spacing (element width) and element sectional area.

3. Operating temperature range

3.1 Own temperature rise

When the film capacitor is used in an AC circuit, especially in high frequency application, the capacitor generates heat by itself from the flow of current. If the self heat generation is large, the capacitor may deteriorate, and smoke or fire may occur. Check the self heating temperature rise value in actual conditions of use, and use within the limit specified.

Measure the own temperature rise value in indoor, wind-free condition.

* The details of self heating temperature rise value are described in the specification. (Please contact us details as the specifies value varies by each type.)

3.2 Operating temperature range

The operating temperature range of the film capacitors varies with the dielectric material (kind of films), and the usable temperature range is specified in the each model.

It must be noted, however, that the temperature range mentioned in the catalogue is the surface temperature of the film capacitor, not the ambient temperature of the capacitor.

In actual use, make sure the sum of the ambient temperature + capacitor's self heating temperature rise value (within specified value), that is, the capacitor surface temperature should be within the rated operating temperature.

⚠ Caution!

When used above the specified operating temperature, dissipation factor ($\tan\delta$) increase, and the self heat generation may exceed the permissible value, possibly causing deterioration of dielectric film, short circuit, and smoke or fire.

If there is cooling plate of other part or any resistance heated to high temperature near the film capacitor, the capacitor may be locally heated by the radiation heat, exceeding the operating temperature range, and smoke or fire may be caused.

Check the capacitor surface temperature at the heat source side.

4. Other cautions**4.1 Flame retardation**

- The dielectric film is not a flame retardant material.
- In the ECQE , ECWF, and ECWH types, flame retardant epoxy resin (94V-0) is used in the coating resin.

4.2 Environments of use**4.2.1 When used in humid environments**

When used for a long period in humid environments, the elements absorb moisture through the coating with the passing of the time. The water oxidizes the electrode (evaporated film and metalized contact), and leads to trouble. Also, make sure the capacitance value can be very large depending on type of the capacitor.

4.2.2 When using in high temperature environment

When ECQUG is used in high temperature environment (more than 70°C), it may be possible to cause leaking oil from the capacitor. However, the quality and reliability of the capacitor is not affected by the leaking oil. But, please don't use the part which may cause a point of tact obstacle by oil and this condenser by a same set.

4.2.3 Cautions on gas atmosphere

When using in the oxidizing gas such as hydrogen chloride, hydrogen sulfide and sulfurous acid, the evaporated electrode (Aluminum) or metalized contact (zinc compound) may be oxidized, may result in smoke or fire. Avoid such atmosphere.

4.2.4 When using by resin coating

When using resin coating or resin potting components to improve humidity resistance or gas resistance, or to fix parts in place. Please contact with us.

- The solvent or the constituent in the resin may permeate into the metalized contact or electrode (aluminum foil or evaporated film) to deteriorate characteristics.
- When hardening the resin, chemical reaction heat (curing heat generation) occurs, which may adversely affect the capacitor.
- In the case of the lead type capacitors, be sure to test and evaluate enough for the thermal stress to the capacitor.

4.2.5 Other

- When using in the following conditions, the characteristic may be deterioration. Please don't use at such conditions.
 - The place that took water or oil.
 - The place that exposed to the direct sunlight.
 - The place that radiated ozone, ultraviolet rays and radiation rays.
- Please consider so that dust doesn't collect. That will be the cause of the characteristic deterioration (short circuit, etc.).

4.3 Changes in capacitance value over time

- The capacitor characteristics change characteristic depending on its ambient conditions and environmental conditions. In natural conditions, there is a certain capacitance change due to the humidity of the circumstance. The degree of such capacitance changes varies with the dielectric material, coating material, and structure. Therefore, we ship considering these changes, but we only guarantee capacitance value until delivery (without each arrangements.)
- For use in a circuit where time constant and capacitance precision are required, use the products of polypropylene film ECWFD/(A)/(L) , ECWH(A) or film ECHU(X)/(C) which vary less with time.

4.4 Hum (Buzz)

- Hum produced by capacitors due to mechanical vibration of the film is caused by the coulomb force which exists between electrodes of opposite polarity. A louder hum is produced when applied voltage waveform has distortion, and/or higher frequency component, etc. Although Hum does not spoil characteristics of capacitors, when being used around the audio frequency, please check it.

4.5 Storing method, storing conditions

- It must be noted that the solderability of the external electrode may deteriorate when stored in an atmosphere filled with moisture, dust, or a reactive oxidizing gas (hydrogen chloride, hydrogen sulfide, sulfuric acid).
- Should not location with particularly high temperature and high humidity, and store in conditions not exceeding 35 °C and 85 % RH.
- When it is kept for a long term, the solderability of the external electrode may deteriorate for oxidation of electrode surface. So we recommend keeping-period is within 6 month. Further, it's different in the condition depending on the items, so please inquire for details.

4.6 Handling Pre cautions

- Sudden charging or discharging may cause deterioration of capacitor such as shorting and opening due to charging or discharging current. When charging or discharging, pass through a resistance of 20 to 1000 Ω/V or more.
- When connecting multiple film capacitors in parallel in withstand voltage test or life test, connect a resistance of 20 to 1000 Ω/V or more in series to each capacitor.
- Be careful not to scratch the capacitor surface with sharp edges (such as screwdriver, soldering iron, pincers, chassis). Don't apply excessive load to the lead wire (at the time of re-processing of lead wire, etc.).
- If the capacitor is dropped by mistake, its characteristics may be damaged. Don't use such a capacitor. (If reusing, check the quality sufficiently.)
- In the case of leaded type capacitor, be careful not to apply excessive force to the lead wire root area, which may cause cracking or separation in the coating resin near the root area.
- No dust or water should be permitted to remain on the surface of capacitor terminals as this may cause electrical leakage or corrosion.
- When used for noise suppression between lines and between line to earth when voltage is more than 30VAC and more than 45VDC, covering peripheral resin part by flame retardant material or flame retardant case (for avoiding fire) is recommended.
- Chip type capacitor is developed assuming normal use of surface mounting parts. Abnormal use (ex: piling up two capacitors, mounting capacitor in upright position, etc.) should not be permitted. Please consult us in advance if used in different way from normal.

4.7 Additional Points

- The precautions in using film capacitors follow the JEITA RCR-2350 D "Safety Application Guide for fixed plastic film capacitors for use in electronic equipment". Please refer to the above guideline.
- Product specifications, materials and other points mentioned in the catalog may be changed without notification.

(Note 1) Rated voltage

The maximum voltage that can be applied continuously in spite of temperature is called as the rated voltage in our company. It's different from the standards of JIS and IEC.

* Definition of our company

The maximum voltage that can be applied continuously within the category temperature range.

- * Even when needing derating voltage at high temperature, the voltage after derating is called the rated voltage. Therefore the maximum voltage that can be applied continuously at upper category temperature is being also called the rated voltage.

! Guidelines and precautions (Chip type)

(Target product : ECHU, ECWU, ECPU)

1. Soldering

Although there are specific restrictive conditions for the chip type, please check and consider the following items in order to guarantee soldering quality. Please consult us when using part adhesive for mounting because there is a possibility that type of adhesive affects the characteristic and the reliability of capacitor.

1.1 Printed wiring board

1.1.1 Selection of printed wiring board

The chip parts are directly mounted on the printed wiring board without using lead wires, and therefore thermal expansion of the printed wiring board may affect the characteristic of the film chip capacitor, and hence the following cautions should be observed.

<Remarks for selecting the printed wiring board>

Item	Point of notice
Coefficient of thermal expansion of printed wiring board	If there is a large difference in coefficient of thermal expansion between the capacitor and Printed wiring board, a mechanical stress is applied due to temperature changes after mounting, and the element main body may be changed, the soldered area may be cracked, and the performance may be lowered. Check sufficiently beforehand.

<Coefficient of thermal expansion>

Type of Printed wiring board Item	Film chip capacitor			Resin Printed wiring board			Ceramic Printed wiring board
	ECHU(X)/(C) (PPS film)	ECWU(X)/(C) (PEN film)	ECPU(A) (Plastic film)	Paper phenol	Paper epoxy	Glass epoxy	Alumina
Coefficient of thermal expansion ($\times 10^{-6}/^{\circ}\text{C}$)	22	10	70	1-30	1-15	1-25	7-8

1.1.2 Parts layout on Printed wiring board

Film chip capacitors, unlike the leaded type film capacitors do not have coating.

Retaliated heat from a near by heated components may cause the temperature to exceed the usable temperature range.

Without coating, if there is an exposed live part in the vicinity, a short circuit may be formed through the capacitor. Consider the arrangement.

1.1.3 Land dimension design

If the land area is wide, tombstone phenomenon (chip rising) is likely to occur in relation to the solder amount.

It is disadvantageous for keeping the mount clearance of the mounting machine, but it is advised to design in the recommended land dimension shown each specifications.

1.2 Flow soldering

In flow soldering, the chip part capacitor is soaked in molten solder. Film capacitor has lower heat resisting temperature than other capacitors, therefore cannot be used in flow soldering.

1.3 Reflow soldering

Reflow soldering is a method of soldering by printing a proper amount of cream solder on the mounting land of the surface mount Printed Wiring Board, putting a film chip capacitor thereon heating, and fusing the cream solder to fix.

1.3.1 Reflow soldering conditions

Perform reflow soldering within the following temperature profile.

(Soldering is within twice, the second dip should be carried after the capacitor itself has returned to normal temperature.)

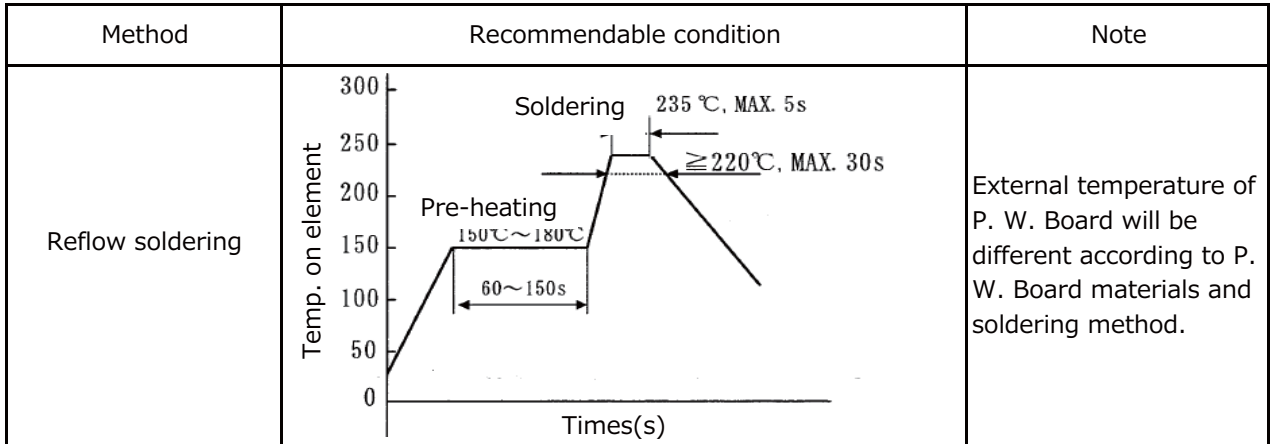

* When performing reflow soldering, an appropriate coating thickness of cream solder is 0.10 mm to 0.15 mm.

1.3.2 Precautions for reflow soldering

- The film chip capacitor has no coating on the capacitor element, and the internal evaporated electrode may be deteriorated due to activating agent (halogen, etc.) in the cream solder, and the capacitance value may decrease, dissipation factor (tan δ) may increase, or the characteristic may be deteriorated. Use cream solder with halogen content of 0.1 wt.% or less.
- When washing right after soldering, make sure the capacitor surface temperature is lower than 60 °C.
- The maximum temperature reached on the element surface in reflow is as follows. If a higher temperature is applied, abnormality may occur on the appearance or electrical characteristics.

Type	Max. temperature on element surface
ECHU(X)/(C)	260°C
ECWU(X)/(C)	250°C
ECPU(A)	240°C

If exceeding the specified temperature, it must be noted that the reliability of the part cannot be guaranteed.

The moisture-proof packaging is made ECWU and ECPU. When that's opened, a capacitor absorbs moisture, and soldering heat-resistance falls to a low level. Please confirm the notice after opening. The notice in detail has decided on Approval Specification.

1.4 When using soldering iron

With a soldering iron, high temperature is directly applied to the film chip capacitor. Abide by the following soldering iron conditions, and strictly control the iron tip temperature

1.4.1 Soldering conditions when using soldering iron.

Observe the following cautions, and use within the soldering conditions next page.

1.4.2 Cautions for use of soldering iron

- Be careful that the soldering irons do not directly touch the main body of the film chip capacitor. In particular, don't touch the side (cut section). If touched by the heated soldering iron, lowering of insulation resistance, shortcircuit or other characteristic deterioration may occur.
- Preheat the printed wiring board land sufficiently with the soldering iron, and then solder. Solder without directly touching the iron tip to the electrode of the capacitor.
- Don't reuse the products once removed by the soldering irons.
- Should not mount the film chip capacitors in the mass production by soldering iron. (The temperature control is difficult, and the characteristics may be deteriorated.)

* Soldering conditions when using soldering iron.

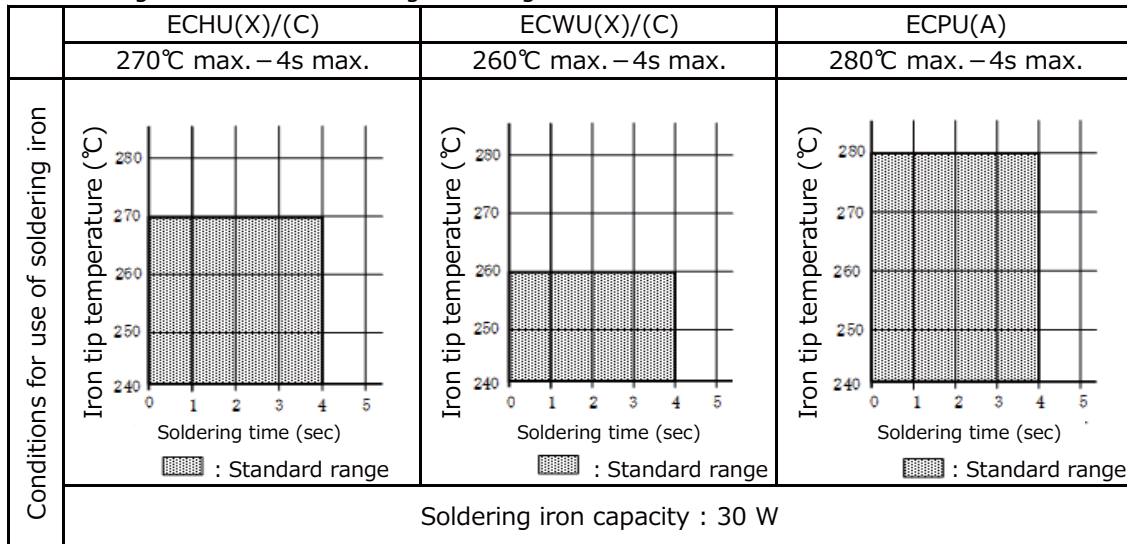

1.5 Other soldering

Should not resolder with heat directly from bottom side of P. W. Board. because capacitor will likely be damaged

2. Washing the mounted boards

Since the film chip capacitor does not have a coating, components of flux or detergent left over on the element at the time of washing may be activated and invade into the inside of the capacitor, and adverse effects may be caused. Observe the following cautions.

- In the case of washing, use flux and cream solder with halogen content of 0.1wt.% or less when
- In the case of ultrasonic washing, note that peeling of protective film, electrode separation due to resonance, or characteristic deterioration may occur depending on the detergent used or ultrasonic output. Check carefully beforehand.
- When using a CFC substitute detergent, with the washing method of spraying detergent (rinsing water)to the substrate at high pressure, the protective film on the element surface may be peeled off due to the water pressure. Check carefully beforehand.

<CFC substitute detergent>

As a result of regulation of CFC and chlorine derivative detergents, many substitute detergents come to be used, but the performance of the film chip capacitor may be reduced depending on the type of detergent or washing condition. Check sufficiently beforehand. Consult us in advance if planning to use CFC substitute detergent.

<Drying after washing>

Dry after washing so that the detergent is not left over. If drying is insufficient, the detergent is left over on the element surface, and the insulation resistance is measured to be lowered. Dry enough so as not to leave detergent.

<Recommended detergent and washing method>

(Recommended detergent)

Classification	Detergent name	Maker
Alcohol derivative	IPA(isopropyl alcohol)	(Reagent for general industrial use)

(Washing method)

Item \ Condition	Temperature	Time
Immersion washing	50°C	Within 5 minutes
Steam washing	50°C	Within 5 minutes
Ultrasonic washing	50°C	Within 5 minutes

For reference, applicability of the film capacitors detergent is listed to the next page.

<List of applicability of detergents>

Washing condition			Chip type
Solvent	Alcohol	Ethanol Ultrasonic washing or immersion washing for 5 min	○
		Isopropyl alcohol (IPA) Ultrasonic washing or immersion washing for 5 min	○
	Silicon	FRW-17Ultrasonic washing for 5 min, 60 °C ⇒FRW-1NUltrasonic washing for 5 min, 60 °C ⇒FRW-100Steam drying for 1 min, 100 °C	○
	Halogen	HCFC141b-MS Ultrasonic washing or immersion washing for 5 min	○
	Petroleum hydrocarbon	P3 Cold Cleaner 225S Ultrasonic washing for 5 min 60 °C ⇒ IPA ultrasonic rinsing for 5 min at ordinary temperature ⇒ hot air drying for 5 min, 40 °C	○
		Toluene Ultrasonic washing or immersion washing for 5 min	×
Terpene	Terpene Cleaner EC-7 Spray washing for 5 min at ordinary temperature ⇒ purified water spraying for 5 min, 50°C ⇒ hot air drying for 5 min, 80°C	×	
Water	Purified water	Ultrasonic washing for 5 min 60 °C ⇒ wind-free dryingfor 5 min, 85 °C	×
	Surface active agent	Clean Through 750H Ultrasonic washing for 5 min, 60 °C ⇒ purified water ultrasonic washing for 5 min, 60 °C ⇒ hot air drying for 5 min, 85 °C	×
		Clean Through 750L Ultrasonic washing for 5 min, 60 °C ⇒ purified water ultrasonic washing for 5 min, 60 °C ⇒ hot air drying for 5 min, 85 °C	×
		Clean Through 710M Ultrasonic washing for 5 min, 60°C ⇒ purified water ultrasonic washing for 5 min, 60 °C ⇒ hot air drying for 5 min, 85 °C	×
		Clean Through LC-841 Ultrasonic washing for 5 min, 60 °C ⇒ purified water ultrasonic washing for 5 min, 60 °C ⇒ hot air drying for 5 min, 85 °C	×
		Pine Alpha ST-100S Ultrasonic washing for 5 min, 60 °C ⇒ purified water ultrasonic washing for 5 min, 60°C ⇒ hot air drying for 5 min, 85 °C	×
		Aqua Cleaner 210SET Shower washing for 1 min, 60 °C ⇒ purified water ultrasonic washing for 5 min, 60 °C ⇒ hot air drying for 5 min, 85 °C	×
○ : Washing enabled × : Washing disabled — : Not confirmed			

<Wash-free flux>

Wash-free	Low residue flux	ULF-500VS	○
	Inactivated flux	AM-173	○

- Washing disabled (x mark) detergent should be avoided because the appearance may be impaired, the characteristic may be deteriorated, and the reliability cannot be guaranteed

3. Temperature measuring in soldering of film capacitor

When using film capacitor of chip type, measure the element temperature profile in mounting in the following manner, and make sure the soldering is done below the heat resisting temperature.

<Preparation of measuring sample>

Fix thermo couple ($\Phi 0.1$ T wire) to the top of the capacitor with adhesive.

<Measurement of temperature profile>

As shown below, connect a thermocouple (3 - 4)m of same type as the thermocouple to the capacitor, to the thermocouple of the capacitor as shown below. Mount the sample on the mounting printed wiring board, and pass into the soldering and mounting process, and measure the temperature profile.

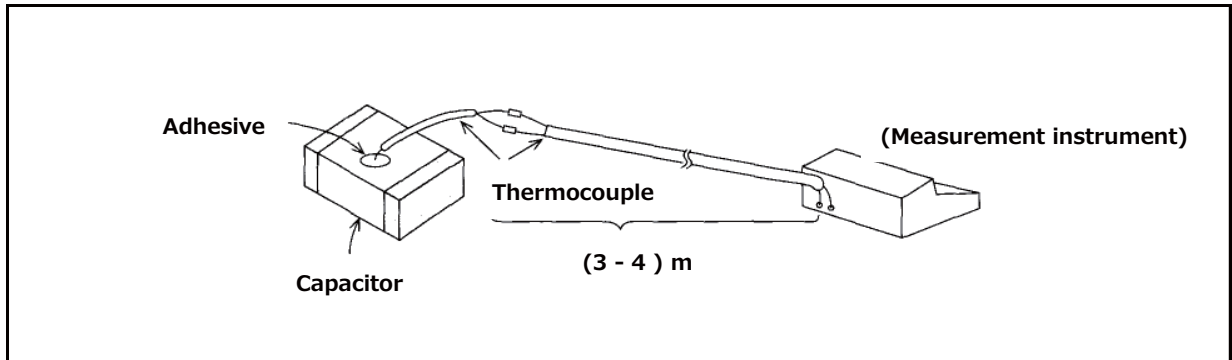

! Guidelines and precautions (Lead type)

(Target product : ECQE, ECWF, ECWH, ECQU)

1. Soldering

The heat resisting temperature of the film capacitor varies with the type of dielectric film, structure of the capacitor, manufacturing method, etc.

When mounting, set the mounting temperature so that the capacitor inside (element) temperature is be lower than the mounting heat resisting temperature given below.

If the capacitors go through the high temperature both after soldering , be sure to check the temperature till decreasing.

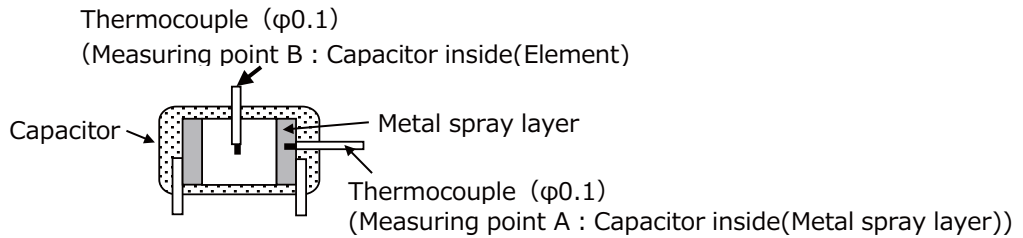

Dielectric	Type	Mounting heat resisting temperature	
		Measuring point A	Measuring point B
Polypropylene	ECWF(L) 400V 0.022μF~0.11μF, 630V 0.01μF~0.043μF ECWF(A)	135°C	125°C
	ECWF(L) 400V 0.12μF~2.4μF, 630V 0.047μF~1.3μF ECWFE 630V, ECWFG 630V	145°C	125°C
	ECWH(A) ,ECWH(V), ECWFD 630V	135°C	125°C
	ECWH(C)	140°C	125°C
	ECWFD 450V	135°C	—
	ECQUA, ECWFE 450V	125°C	—
	ECQE(F)	—	120°C
	ECQE(B), ECQE(T), ECQUL, ECQUG	160°C	—

<Cautions for mounting>

- Solder within the following temperature condition range. (Dipping times is within twice, the second dipping should be carried after the capacitor itself has returned to the normal tempeprature)(Example)

Notice:
The soldering condition shows one example. The temperature of the capacitors depend on several parameters for example soldering machine size , machine structure, temperature control method, etc..
Should measure the temperature of the capacitors and confirm the temperature under the above table.

Conditions

P. W. Board	Thickness t= 0.8mm or more
Pre-heating	Measurement temperature 120 °C within 1 minute (Back side of the P. W. Board around the capacitor)
Capacitor	Raised from P,W. board (Crimped lead)

- The film capacitor has lower mounting heatresistingtemperature than other capacitors,therefore the following cautions are needed.
Avoid passing through an adhesive curing oven. After adhesive curing, the capacitor should be inserted in the P.W. board and solder. (When passing an adhesive curing oven, breakage of coating resin or deterioration in capacitor characteristic may be caused.)
- Avoid reflow soldering. (When use in reflow soldering, breakage of coating resin or deterioration in capacitor characteristic may be caused.)

- When using in multilayer Printed wiring board, or in the case of a capacitor with a copper lead wire, please contact with us. (In the case of copper lead wire, the thermal conductivity of the copper wire is high, and the internal temperature of the capacitor rises rapidly and may exceed the mounting heat resisting temperature.)

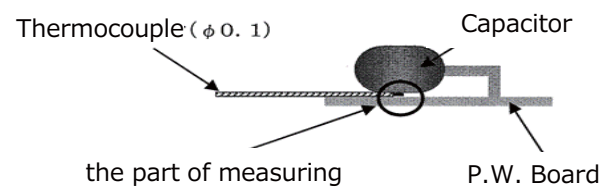

2. Washing the mounted boards

The film capacitor varies significantly in the effect of washing depending on the structure and material, and generally it is less affected by CFC or alcohol derivative washing solvent, and is likely to be affected by highly polar solvent.

The lead type film capacitor is coated with an epoxy resin excellent in chemical resistance, and is hardly affected by detergent, but it is recommended to be washed for short duration.

Applicability of detergents in film capacitors is listed for reference.

<List of applicability of detergents>

Washing condition		Lead type	Box type	
			ECWFE	ECWFG
Solvent	Alcohol	Ethanol Ultrasonic washing or immersion washing for 5 min	○	○
		Isopropyl alcohol (IPA) Ultrasonic washing or immersion washing for 5 min	○	○
	Silicon	FRW-17Ultrasonic washing for 5 min, 60 °C ⇒FRW-1NUltrasonic washing for 5 min, 60 °C ⇒FRW-100Steam drying for 1 min, 100 °C	○	○
		Halogen	HCFC141b-MS Ultrasonic washing or immersion washing for 5 min	○
	Petroleum hydrocarbon	P3 Cold Cleaner 225S Ultrasonic washing for 5 min 60 °C ⇒ IPA ultrasonic rinsing for 5 min at ordinary temperature ⇒ hot air drying for 5 min, 40 °C	○	○
		Toluene Ultrasonic washing or immersion washing for 5 min	○	○
Terpene	Terpene Cleaner EC-7 Spray washing for 5 min at ordinary temperature ⇒ purified water spraying for 5 min, 50°C ⇒ hot air drying for 5 min, 80°C	○	○	
Water	Purified water	Ultrasonic washing for 5 min 60 °C ⇒ wind-free drying for 5 min, 85 °C	○	○
	Surface active	Clean Through 750H Ultrasonic washing for 5 min, 60 °C ⇒ purified water ultrasonic washing for 5 min, 60 °C ⇒ hot air drying for 5 min, 85 °C	○	○
		Clean Through 750L Ultrasonic washing for 5 min, 60 °C ⇒ purified water ultrasonic washing for 5 min, 60 °C ⇒ hot air drying for 5 min, 85 °C	○	—
		Clean Through 710M Ultrasonic washing for 5 min, 60°C ⇒ purified water ultrasonic washing for 5 min, 60 °C ⇒ hot air drying for 5 min, 85 °C	○	—
		Clean Through LC-841 Ultrasonic washing for 5 min, 60 °C ⇒ purified water ultrasonic washing for 5 min, 60 °C ⇒ hot air drying for 5 min, 85 °C	○	○
		Pine Alpha ST-100S Ultrasonic washing for 5 min, 60 °C ⇒ purified water ultrasonic washing for 5 min, 60°C ⇒ hot air drying for 5 min, 85 °C	○	○
		Aqua Cleaner 210SET Shower washing for 1 min, 60 °C ⇒ purified water ultrasonic washing for 5 min, 60 °C ⇒ hot air drying for 5 min, 85 °C	○	○
○ : Washing enabled × : Washing disabled — : Not confirmed				

<Wash-free flux>

Wash-free	Low residue flux	ULF-500VS	○	○
	Inactivated flux	AM-173	○	○

3. Temperature measuring in soldering of film capacitor

When using film capacitor of low heat resisting temperature in mounting, measure the element temperature profile in mounting in the following manner, and make sure the soldering is done below the heat resisting

<Preparation of measuring sample>

Open a hole of about $\Phi 0.3$ mm to 0.8 mm in the top of the capacitor to the middle of the element, and insert thermocouple ($\Phi 0.1$ T wire), and fix with adhesive.

<Measurement of temperature profile>

As shown below, connect a thermocouple (3 - 4)m of same type as the thermocouple attached to the capacitor, to the thermocouple of the capacitor as shown below. Mount the sample on the mounting printed wiring board, and pass into the soldering and mounting process, and measure the temperature profile

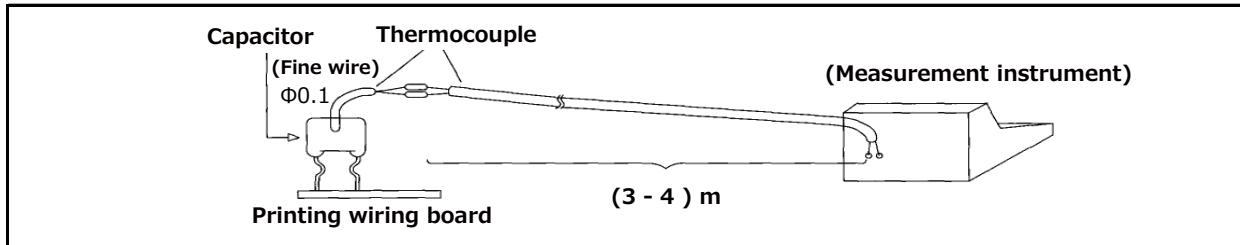

4. Capacitor for prevention of AC power supply (across the line) noise

- When using a capacitor across the line as means for prevention of noise, not only is the supply voltage is always applied, but also abnormal surge such as lightning is applied, which may lead to smoke or fire. Therefore, the across-the-line capacitors are strictly regulated in safety standard in each nation, and it is necessary to use the product conforming to the standard.

For using across the line in Japan, use the following models or the above overseas authorized ones.

- ECQE(F) 1000VDC (125VAC) rating
- ECQE(F) 1250VDC (125VAC) rating
- ECQE(F)/(B)/(T) 125VAC (1A) rating
- ECQE(F)/(T) 250VAC (2A) rating

However, when using the ECQE(F)1A/2A, ECQE(B)1A, ECQE(T)1A/2A rating model as across-the-line capacitor, at least one of the following conditions must be satisfied.

1. A varistor with the voltage of the value or less shown in the following table should be connected to the capacitor in parallel.
2. A pulse voltage more than the value shown in the table below should not be applied across the capacitor.

(Note) When using together with varistor, check the varistor specification, and select the one free from surge deterioration

Cap. Rated Voltage	Varistor Voltage	Pulse Voltage
125VAC (1A)	250V	250Vo-p
250VAC (2A)	470V	630Vo-p

When Safety standard approval capacitor is used for necessary equipment, please use items of the following table.

<Representative examples of models authorized in major safety standards in the world>

Shape	Type	Standard
Plastic case type	ECQUA	UL 60384-14(USA), CSA E60384-14(Canada), EN 60384-14(Europe)
Plastic case type	ECQUL	UL 60384-14(USA), CSA E60384-14(Canada), EN 60384-14(Europe)
Plastic case type	ECQUG	UL 60384-14(USA), CSA E60384-14(Canada), EN 60384-14(Europe)

*Please contact us about CQC(China).

- In the case of the voltage dropper usage, when an abnormal voltage of the surge voltage etc. is applied the capacitance decrease is caused, such as the fuse function in the capacitor operates. In the worst case, the capacitor does not work as voltage dropper. So, please notice an abnormal voltage. At that time, high voltage may be applied to the load side. Therefore, please provide protective means for safety.
- AEC-Q200 compliant
The products are tested based on all or part of the test conditions and methods defined in AEC-Q200. Please consult with Panasonic for the details of the product specification and specific evaluation test results, etc., and please review and approve Panasonic's product specification before ordering.

Electronic Equipment Use

Dielectric	Series
Stacked Metallized PPS Film Chip Capacitor	ECHU (X)
	ECHU (C)
Stacked Metallized PEN Film Chip Capacitor	ECWU (X)
	ECWU (C)
	ECWU (V16)
Stacked Metallized Plastic Film Chip Capacitor	ECPU (A)
Metallized Polyester Film Capacitor	ECQE (F)
	ECQE (B)
	ECQE (T)
Metallized Polypropylene Film Capacitor	ECWF (L)
	ECWF (A)
	<small>UPGRADE</small> ECWFD
	<small>UPGRADE</small> ECWFE
	ECWH (V)
	ECWH (A)
	ECWH (C)
TMF	
Metallized Polypropylene Film Capacitor	ECQUA
Metallized Polyester Film Capacitor	★ECQUL
	★ECQUG

★Not Recommended for New Design

AC Motor Use

Dielectric	Series
Film Capacitor for AC Motor	AMF
	DMF
	PMF/SMF

Automotive, Industrial and Infrastructure Use

Dielectric	Series
Metallized Polyester Film Capacitor for Noise Suppression of Automobile	ECQE
Metallized Polypropylene Film Capacitor	<small>UPGRADE</small> ECWFG
Metallized Polypropylene Film Capacitor	ECQUA (Automotive)
DC-Link Film Capacitor	Type1
Metallized Polypropylene Film Capacitor	EZPE
	EZPE (Low profile)
	<small>UPGRADE</small> EZPQ
	<small>NEW</small> EZPV

Electronic Equipment Use



	Dielectric	Series	Appearance	Operating Temp*	Rating	Structure·Feature	Application	
Stacked Metallized Film Chip Capacitor	Stacked Metallized PPS Film Chip Capacitor	ECHU(X)		-55 °C to +125 °C	0.00010 μF to 0.22 μF 16 V.DC, 50 V.DC	<ul style="list-style-type: none"> ● Non-inductive, Stacked ● Tight C-Tol. ● Reflow soldering 	● High density mounting	
		ECHU(C)		-55 °C to +105 °C	0.010 μF to 0.22 μF 100 V.DC	<ul style="list-style-type: none"> ● Non-inductive, Stacked ● Tight C-Tol. ● Reflow soldering 	<ul style="list-style-type: none"> ● High density mounting ● Resonance circuit for LCD B/L inverter unit 	
	Stacked Metallized PEN Film Chip Capacitor	ECWU(X)		-55 °C to +105 °C	0.0010 μF to 0.010 μF 100 V.DC	<ul style="list-style-type: none"> ● Non-inductive ● Reflow soldering 	● High density mounting	
		ECWU(C)		-55 °C to +125 °C	0.0010 μF to 1.0 μF 100 V.DC to 630 V.DC	<ul style="list-style-type: none"> ● Non-inductive ● Reflow soldering 	<ul style="list-style-type: none"> ● Ringer circuit telephone PBX ● DC Blocking for xDSL 	
		ECWU(V16)		-55 °C to +85 °C	0.0010 μF to 0.12 μF 250 V.DC	<ul style="list-style-type: none"> ● Non-inductive ● Reflow soldering 	<ul style="list-style-type: none"> ● Ringer circuit telephone PBX ● DC Blocking for xDSL 	
	Stacked Metallized Plastic Film Chip Capacitor	ECPU(A)		-40 °C to +85 °C	0.10 μF to 1.0 μF 16 V.DC	<ul style="list-style-type: none"> ● Non-inductive ● Reflow soldering 	<ul style="list-style-type: none"> ● Noise suppressor ● Audio circuit 	
Metallized Type	Metallized Polyester Film Capacitor	ECQE(F)		-40 °C to +105 °C	0.0010 μF to 10 μF 100 V.DC to 1250 V.DC, 125 V.AC, 250 V.AC	<ul style="list-style-type: none"> ● Epoxy resin coating ● Wide capacitance range 	<ul style="list-style-type: none"> ● General purpose ● Noise suppressor 	
		ECQE(B)		-40 °C to +105 °C	0.010 μF to 4.7 μF 250 V.DC 125 V.AC	<ul style="list-style-type: none"> ● Epoxy resin coating ● Miniaturization of ECQE(F) type 	<ul style="list-style-type: none"> ● General purpose ● Noise suppressor 	
		ECQE(T)		-40 °C to +105 °C	0.010 μF to 10 μF 250 V.DC to 630 V.DC 125 V.AC, 250 V.AC	<ul style="list-style-type: none"> ● Epoxy resin coating ● Excellent moisture resistance 	● Electric circuit of high humidity equipment	
	Metallized Polypropylene Film Capacitor	ECWF(L)		-40 °C to +105 °C	0.010 μF to 2.4 μF 400 V.DC, 630 V.DC	<ul style="list-style-type: none"> ● Epoxy resin coating ● Low D.F ● Excellent moisture resistance 	● High frequency high current circuit	
		ECWF(A)		-40 °C to +105 °C	0.10 μF to 6.8 μF 250 V.DC to 630 V.DC	<ul style="list-style-type: none"> ● Miniaturization of ECWF(L) type ● Low D.F 	<ul style="list-style-type: none"> ● Active filtering circuit ● High frequency high current circuit 	
		UPGRADE ECWFD		-40 °C to +110 °C	0.1 μF to 4.7 μF 450 V.DC	<ul style="list-style-type: none"> ● Epoxy resin coating ● Low D.F ● Miniaturization of ECWF(A) type 	<ul style="list-style-type: none"> ● Active fi ltering circuit ● High frequency high current circuit 	
		-40 °C to +105 °C	0.01 μF to 4.7 μF 630 V.DC					
		UPGRADE ECWFE		-40 °C to +105 °C	0.10 μF to 4.7 μF 450 V.DC, 630 V.DC	<ul style="list-style-type: none"> ● Box type ● Low D.F 	<ul style="list-style-type: none"> ● Active fi ltering circuit ● High frequency high current circuit 	
		ECWH(V)		-40 °C to +105 °C	0.0010 μF to 0.10 μF 1000 V.DC to 2000 V.DC	<ul style="list-style-type: none"> ● Epoxy resin coating ● Low D.F ● Small in size 	● High frequency high current circuit	
		ECWH(A)		-40 °C to +105 °C	0.0010 μF to 0.047 μF 800 V.DC, 1600 V.DC	<ul style="list-style-type: none"> ● Epoxy resin coating ● Low D.F ● Miniaturization of ECWH(V) type 	● General resonance circuit	
	ECWH(C)		-40 °C to +105 °C (+85 °C)	0.0024 μF to 0.33 μF 630 V.DC to 3000 V.DC	<ul style="list-style-type: none"> ● Epoxy resin coating ● Low D.F 	<ul style="list-style-type: none"> ● General resonance circuit ● Microwave oven ● IH resonance circuit 		
	TMF		-25 °C to +85 °C	(Smoothing circuit) 1 μF to 10 μF 150 V.AC to 220 V.AC 350 V.DC to 630 V.DC (Resonance circuit) 0.01 μF to 4.0 μF 300 V.AC to 2300 V.AC 500 V.DC to 1200 V.DC	<ul style="list-style-type: none"> ● Wide voltage range up to 2300 V.AC ● High frequency and high current capability ● Low loss/Low ESR ● Long life time / High reliability ● Flame retardant 	● General resonance and smoothing circuits for IH and Industry		
	Interference Suppressors (Safety standard approval capacitors)	Metallized Polypropylene Film Capacitor	ECQUA		-40 °C to +110 °C	0.10 μF to 4.7 μF 275 V.AC	<ul style="list-style-type: none"> ● Box type ● UL, CSA, VDE Approved (ClassX2) 	Worldwide ● Noise suppressor for AC line
		Metallized Polyester Film Capacitor	★ECQUL		-40 °C to +100 °C	0.0010 μF to 2.2 μF 275 V.AC(250 V.AC)	<ul style="list-style-type: none"> ● Box type ● UL, CSA, VDE Approved (ClassX2/Y2) 	Worldwide ● Noise suppressor for AC line
★ECQUG				-40 °C to +100 °C	0.010 μF to 1.0 μF 300 V.AC(250 V.AC)	<ul style="list-style-type: none"> ● Equipped with a safety mechanism ● UL, CSA, VDE, ENEC Approved (ClassX1) 	Worldwide ● Noise suppressor for AC line	

* Operating temp. : Including temperature-rise on unit surface.









★ Not Recommended for New Design

* Refer to each product page for details.

AC Motor Use

Dielectric	Series	Appearance	Operating Temp*	Rating	Structure·Feature	Application
Film Capacitor for AC Motor	AMF		-25 °C to +70 °C	10 μF to 40 μF 180 V.AC to 440 V.AC	<ul style="list-style-type: none"> ● High safety (with safety function) ● High reliability ● Small size, lightness, and low loss 	● Motor and compressor (for running)
	DMF		-25 °C to +70 °C	10 μF to 60 μF 180 V.AC to 450 V.AC	<ul style="list-style-type: none"> ● High safety (with safety device) ● High reliability, safety standard approval ● Small size, lightness, and low loss 	● Motor and compressor (for running)
	PMF/SMF		-25 °C to +70 °C	0.5 μF to 65 μF 150 V.AC to 500 V.AC	<ul style="list-style-type: none"> ● High safety (with safety function) ● High reliability, safety standard approval ● Small size, lightness, and low loss 	● Motor and small compressor (for running)

Automotive, Industrial and Infrastructure Use

Dielectric	Series	Appearance	Operating Temp*	Rating	Structure·Feature	Application
Metallized Polyester Film Capacitor for Noise Suppression of Automobile	ECQE		-40 °C to +130 °C	0.47 μF, 2.2 μF, 4.7 μF 250 V.DC	● Box type	● Noise suppressor for automobile
Metallized Polypropylene Film Capacitors	UPGRADE ECWFG		-40 °C to +110 °C	1.0 μF to 5.0 μF 630 V.DC, 1100 V.DC	<ul style="list-style-type: none"> ● AEC-Q200 compliant ● High safety (with safety function) ● Excellent moisture resistance ● High thermal shock resistance 	<ul style="list-style-type: none"> ● xEV charging circuit ● DC/DC, AC/DC converter (smoothing, PFC)
Metallized Polypropylene Film Capacitors	ECQUA		-40 °C to +110 °C	0.1 μF to 4.7 μF 275 V.AC	<ul style="list-style-type: none"> ● AEC-Q200 compliant ● High safety (with safety function) ● Excellent moisture resistance ● High thermal shock resistance 	<ul style="list-style-type: none"> ● xEV charging circuit ● AC/DC converter (Noise suppression)
DC-Link Film Capacitor	Type1		-40 °C to +105 °C	581 μF 450 V.DC	<ul style="list-style-type: none"> ● High safety, Self-healing and Self-protecting function built in. ● No catastrophic failure upon natural end of life due to inbuilt fuse function. 	● Any automotive and /or other application requiring DC Linkage function.
Metallized Polypropylene Film Capacitors	EZPE		-40 °C to +85 °C	10 μF to 110 μF 500 V.DC to 1300 V.DC	<ul style="list-style-type: none"> ● High safety (with safety function) ● Long product life, High reliability ● Low loss, Low ESR ● Flame retardant 	<ul style="list-style-type: none"> ● DC filtering ● DC link circuit
	EZPE <small>(Low profile type)</small>		-40 °C to +85 °C	29 μF : 450 V.DC 66 μF : 525 V.DC 12 μF : 575 V.DC 10 μF : 630 V.DC	<ul style="list-style-type: none"> ● High safety (with safety function) ● Long product life, High reliability, High moisture resistance ● Low loss, Low ESR ● Flame retardant 	<ul style="list-style-type: none"> ● Solar inverters, Micro inverters ● Wind power generation ● Industrial power supplies ● Inverter circuit in appliances (Air Conditioners etc.)
	UPGRADE EZPQ		-40 °C to +85 °C	12 μF to 36 μF 250 V.AC	<ul style="list-style-type: none"> ● High safety (with safety function) ● Long product life, High reliability ● Low loss, Low ESR ● Flame retardant ● High moisture resistance 	● AC Filter
	NEW EZPV		-40 °C to +105 °C	3 μF to 110 μF 600 V.DC to 1100 V.DC	<ul style="list-style-type: none"> ● High Safety (with safety function) ● Long product life, High reliability ● Low loss, Low ESR ● Flame retardant (Case and sealing resin) ● AEC-Q200 compliant (For automotive Part No.) 	<ul style="list-style-type: none"> ● For DC filtering ● DC link circuit ● Solar inverters ● Wind power generation ● Industrial power supplies ● Inverter circuit in appliances ● On board charger

* Operating temp. : Including temperature-rise on unit surface.

* Refer to each product page for details.

Series system diagram

Surface mounting type

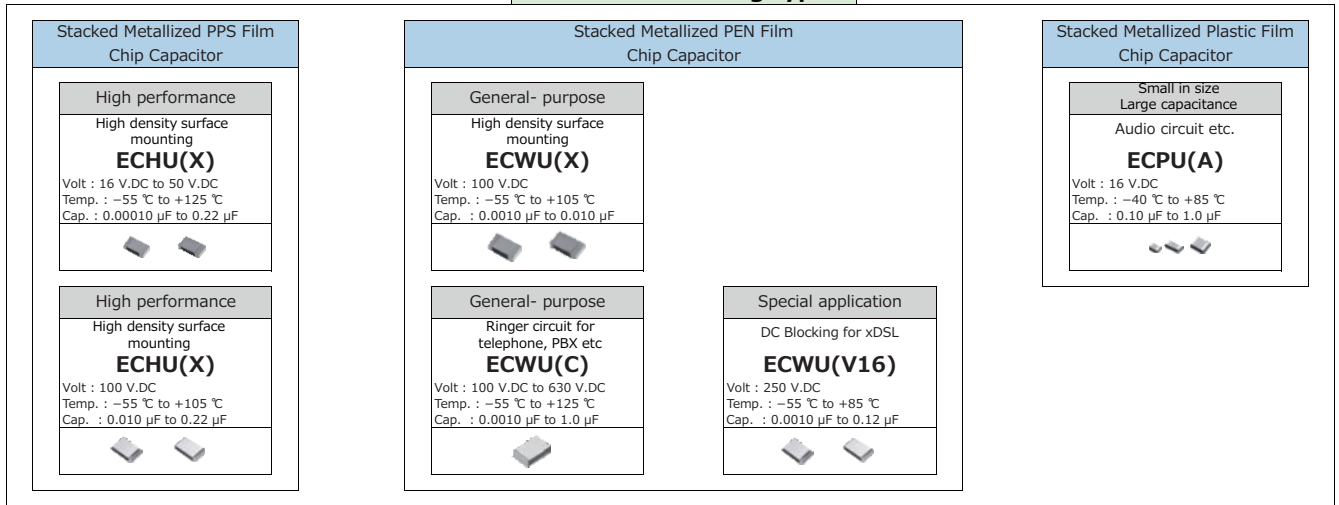

Radial lead type

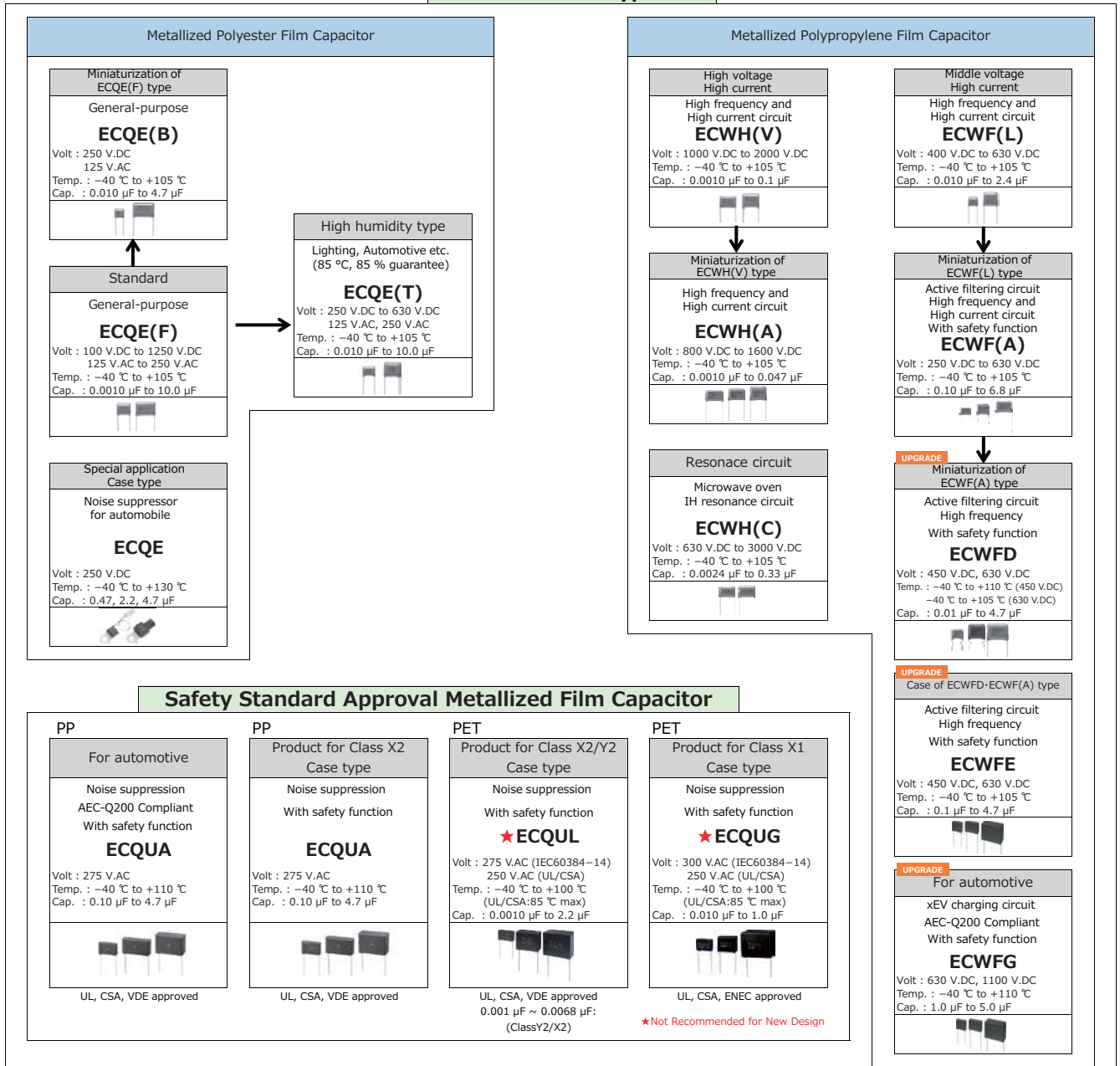

Switching Power Supply

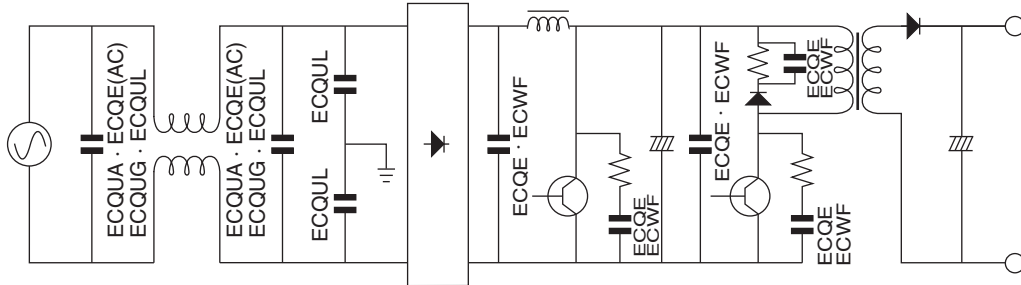

Lighting

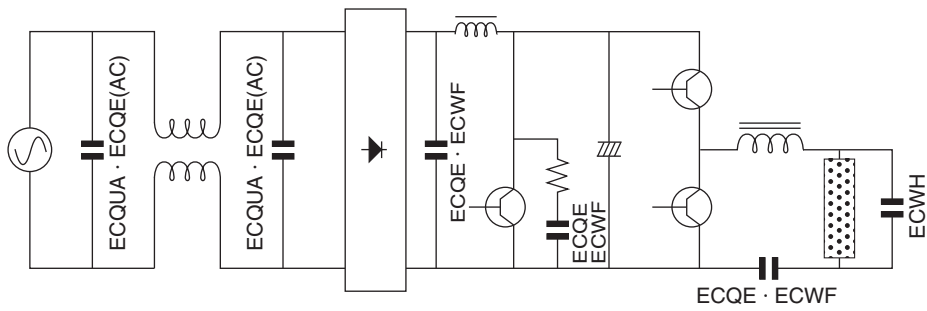

Audio

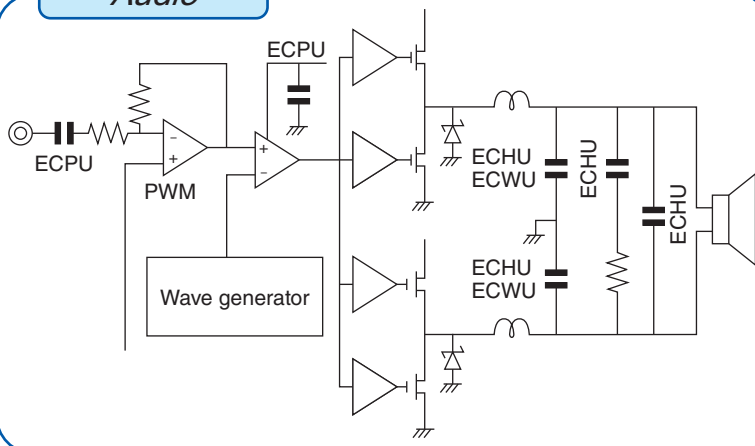

Non-contact charger

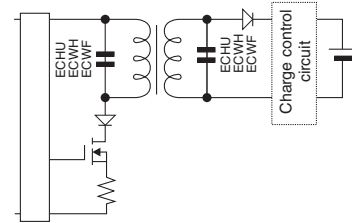

xDSL

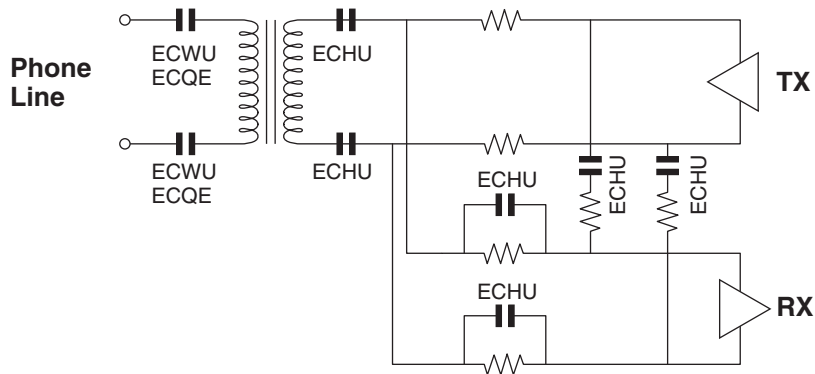

Microwave oven(IH)

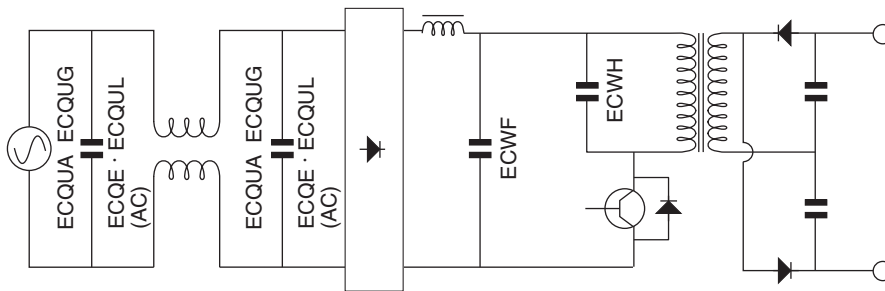

Automobile

Hybrid car DC/DC Converters

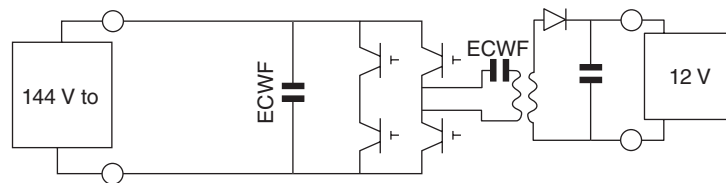

Smart Keyless

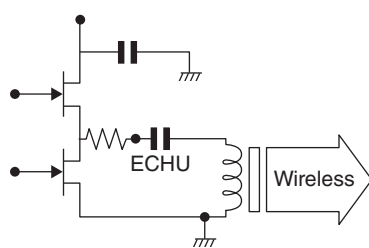

Ignition

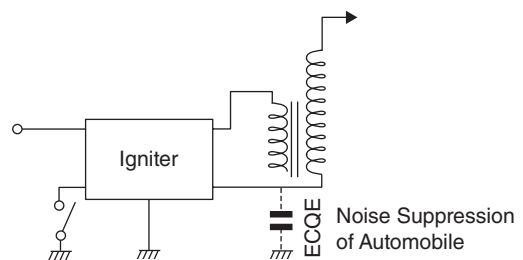

Permissible voltage (R.M.S) in alternating current corresponding to DC rated voltage

1. In case of applying voltage in alternating current (50 Hz or 60 Hz sine wave) to a capacitor, permissible voltage (R.M.S) in alternating current is shown in the following table.
2. Permissible voltage (R.M.S) in alternating current is not an AC rated voltage.
3. The capacitor of DC rating should not be used at the primary side of power supplies.
4. The peak value (zero-to-peak) including pulse of voltage applied capacitor of DC rating should be less than DC rated voltage.

The permissible pulse current is different in each type of the capacitor, please request the product specifications.

5. Please request the product specifications or consult us about details of permissible voltage (R.M.S) in alternating current.

Series		Rated voltage (V.DC)	Permissible voltage (R.M.S) in alternating current (V.AC)
ECHU(X)	ECHU1C(X)	16	11
	ECHU1H(X)	50	30
ECHU(C)	ECHU1(C)	100	40
ECWU(X)	ECWU1(X)	100	40
ECWU(C)	ECWU1(C)	100	40
	ECWU2(C)	250	125
	ECWUC2J	630	250
ECPU(A)	ECPU1C(A)	16	12
ECQE(F)	ECQE1(F)	100	63
	ECQE2(F)	250	150
	ECQE4(F)	400	200
	ECQE6(F)	630	250
	ECQE10(F)	1000	400
	ECQE12(F)	1250	500
ECQE(B)	ECQE2(B)	250	125
ECQE(T)	ECQE2(T)	250	150
	ECQE4(T)	400	200
	ECQE6(T)	630	250
ECWF(A)	ECWF2(A)	250	125
	ECWF2W(A)	450	84
	ECWFA2J	630	141
UPGRADE ECWFD	ECWFD2W	450	84
	ECWFD2J	630	141
UPGRADE ECWFE	ECWFE2W	450	84
	ECWFE2J	630	141
UPGRADE ECWFG	ECWFG2J	630	141
	ECWFG1B	1100	90
ECWF(L)	ECWF4(L)	400	141
	ECWF6(L)	630	223
ECWH(A)	ECWH8(A)	800	283
	ECWHA3C	1600	700
ECWH(C)	ECWH6(C)	630	223
	ECWHC3B	1250	450
	ECWHC3F	3000	1060
ECWH(V)	ECWH10(V)	1000	283
	ECWH12(V)	1250	354
	ECWH16(V)	1600	424
	ECWH20(V)	2000	531

Taping type

Shape	Name	Specification	Taping style
Radial type	Standard taping	5 mm lead spacing with 12.7 mm body width	AD, AS, AB
	Odd size taping (I)	5 mm, 7.5 mm lead spacing with 15 mm & up body width	B, C, D, E, F
	Odd size taping (II)	Other than above	Please consult
Chip type	Embossed taping	Apply for chip type	8 mm, 12 mm, 16 mm, 24 mm carrier tape

Radial type taping

● Standard taping

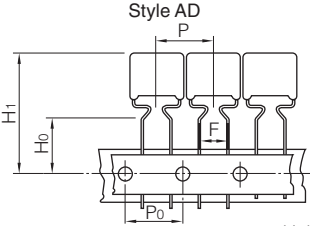
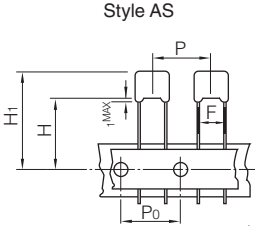
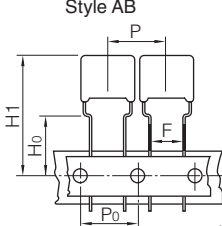
	Style AD	Style AS	Style AB
			
	Unit : mm	Unit : mm	Unit : mm
P	12.7	12.7	12.7
P ₀	12.7	12.7	12.7
F	5.0	5.0	5.0
H ₀	16.0	(H)18.0 — 20.0	16.0
H ₁	34.0 max.	34.0 max.	34.0 max.

Note : H₁ dimension is based on insertion machine "Panaset RH series" made by Panasonic.
Consult with Panasonic technical staff when using other insertion machines.

● Odd size taping (I)

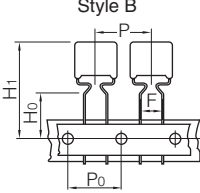
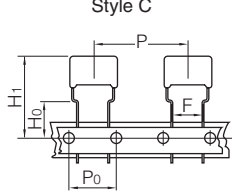
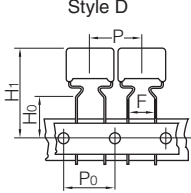
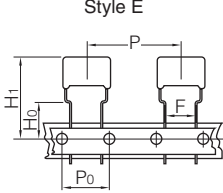
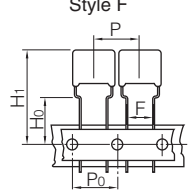
	Style B	Style C	Style D	Style E	Style F
					
	Unit : mm	Unit : mm	Unit : mm	Unit : mm	Unit : mm
P	15.0	25.4	15.0	30.0	15.0
P ₀	15.0	12.7	15.0	15.0	15.0
F	5.0	5.0	7.5	7.5	7.5
H ₀	16.0	16.0	16.0	16.0	16.0
H ₁	39.0 max	39.0 max.	44.0 max.	44.0 max.	44.0 max.

Note : H₁ dimension is based on insertion machine "Panaset RH series" made by Panasonic.
Consult with Panasonic technical staff when using other insertion machines.

● Odd size taping (II)

If the specification of taping is changed by various conditions, including, dimensions, lead spacing and insertion machine, please contact the nearest sales office for further information.

Dimensions

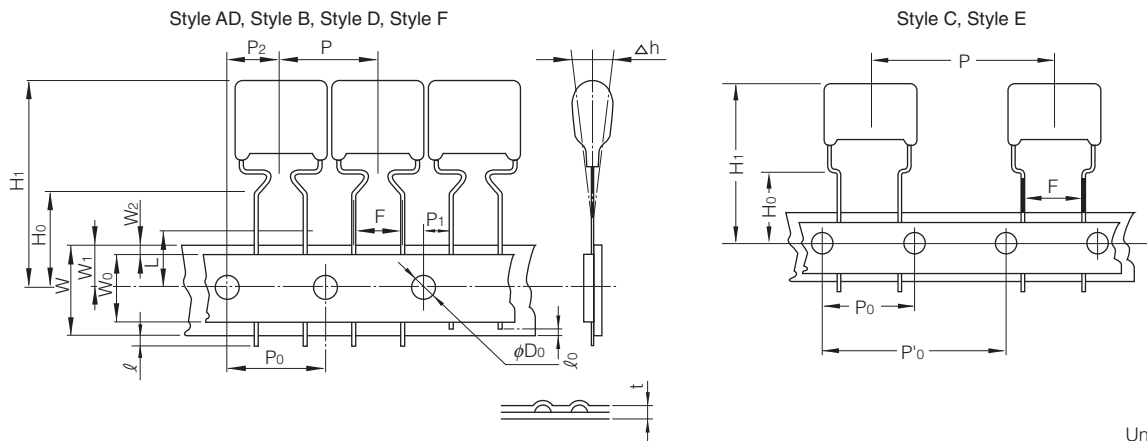

Unit : mm

Code	Style AB, AD, AS	Style B	Style C	Style D, F	Style E
P	12.7±1.0	15.0±1.0	25.4±1.0	15.0±1.0	30.0±1.0
P ₀	12.7±0.2	15.0±0.2	12.7±0.2	15.0±0.2	15.0±0.2
P' ₀	—	—	25.4±0.2	—	30.0±0.2
P ₁	3.85±0.50	5.0±0.5	3.85±0.50	3.75±0.50	3.75±0.50
P ₂	6.35±1.30	7.5±1.3	6.35±1.30	7.5±1.3	7.5±1.3
F	5.0 ^{+0.8} _{-0.2}	5.0 ^{+0.8} _{-0.2}	5.0 ^{+0.8} _{-0.2}	7.5 ^{+0.8} _{-0.2}	7.5 ^{+0.8} _{-0.2}
Δh	0±2.0				
W	18.0±0.5				
W ₀	9.5 min.				
W ₁	9.0±0.5				
W ₂	0 — 3.0				
H ₀	16.0±0.5*	16.0±0.5	16.0±0.5	16.0 ^{+1.0} ₀	16.0 ^{+1.0} ₀
H ₁	34.0 max.	39.0 max.	39.0 max.	44.0 max.	44.0 max.
l	0				
l ₀	7.0 max.				
φD ₀	4.0±0.2				
t	0.7±0.2				
L	11.0 max.				

* Style AS is 18.0 – 20.0 in code H.

Note : H₁ dimension is based on insertion machine "Panaset RH series" made by Panasonic.
Consult with Panasonic technical staff when using other insertion machines.

Packing

Ammo Packing

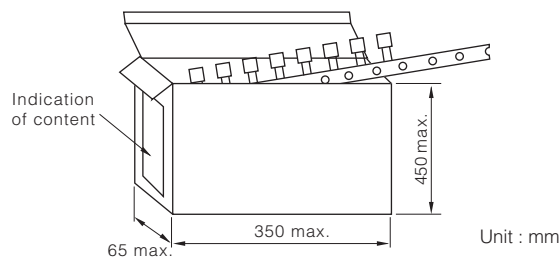

Ammo Box depends on capacitor's dimensions, taping style and quantity.

Chip type embossed taping

● Embossed taping

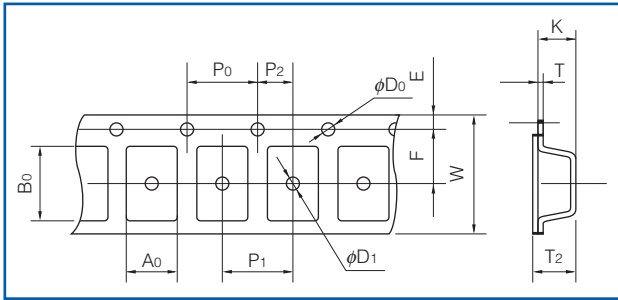

● Standard packaging quantities

Size code	Reel	Quantity
K1	φ180	4000 pcs/reel
J1, J2, H1, H2	φ180	3000 pcs/reel
H3, G1, G2, G3	φ180	2000 pcs/reel
E1, E2, D1, D2	φ330	3000 pcs/reel
E3a, E3, D3, D4, D5	φ330	2000 pcs/reel
B, Z	φ330	1500 pcs/reel
X, Y, V	φ330	1000 pcs/reel

Size code	Dimensions (mm)												
	A ₀ ±0.10	B ₀ ±0.10	W±0.3	F±0.05	E±0.10	P ₁ ±0.1	P ₂ ±0.05	P ₀ ±0.1	φD ₀ ^{+0.1} ₀	φD ₁ ^{+0.2} ₀	T±0.05	T ₂ ±0.2	K±0.1
K1	1.00	1.85	8.0	3.50	1.75	4.0	2.00	4.0	1.5	1.0	0.25	1.0	0.9
J1	1.55	2.30											1.3
J2	1.55	2.30											1.5
H1, H2	1.90	3.50											1.5
H3	1.90	3.50											1.9
G1, G2	2.80	3.50											1.9
G3	2.80	3.50	2.5	2.4									
E1	3.80	5.10	12.0	5.50	1.75	8.0	2.00	4.0	1.5	1.5	0.30	1.9	
E2	3.80	5.10										2.6	
E3a, E3	3.80	5.10										3.4	
D1, D2	4.60	6.30	12.0	5.50	1.75	8.0	2.00	4.0	1.5	-	0.30	2.6	
D3, D4	4.60	6.30										3.5	
D5	4.60	6.30										4.6	
B	5.50	6.30										5.1	
Z	5.50	7.50	4.7	4.6									

Size code	Dimensions (mm)												
	A ₀ ±0.1	B ₀ ±0.1	W ^{+0.3} _{-0.1}	F±0.1	E±0.10	P ₁ ±0.1	P ₂ ±0.1	P ₀ ±0.1	φD ₀ ^{+0.10} ₀	φD ₁ ^{+0.25} ₀	T±0.02	T ₂ ±0.2	K±0.1
X, Y	6.9	8.4	16.0	7.5	1.75	12.0	2.0	4.0	1.50	1.50	0.34	5.7	
V	8.9	10.5										5.9	

● Reel dimensions

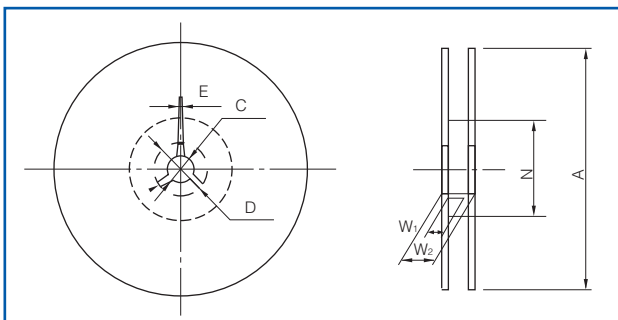

● Leader part and tape end

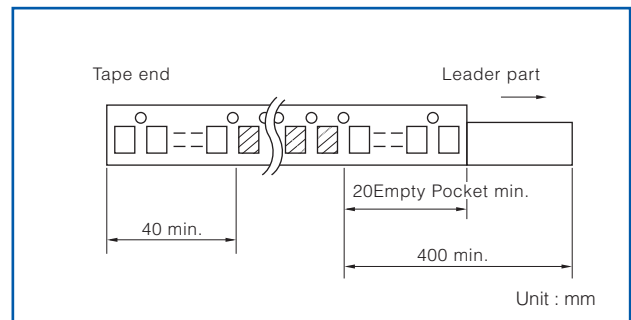

Code	Dimensions (mm)		
	Reel size φ180	Reel size φ330	
		Tape width 8	Tape width 12
A	180.0 ⁰ _{-1.5}	330.0±2.0	
C	13.0±0.2	13.0±0.2	
D	21.0±0.8	21.0±0.8	
E	2.0±0.5	2.0±0.5	
N	60.0 ^{+1.0} ₀	80.0±1.0	
W ₁	9.0 ^{+1.0} ₀	13.4±1.0	17.4±1.0
W ₂	11.4±1.0	17.4±1.0	21.4±1.0

Temperature characteristics

Typical curve

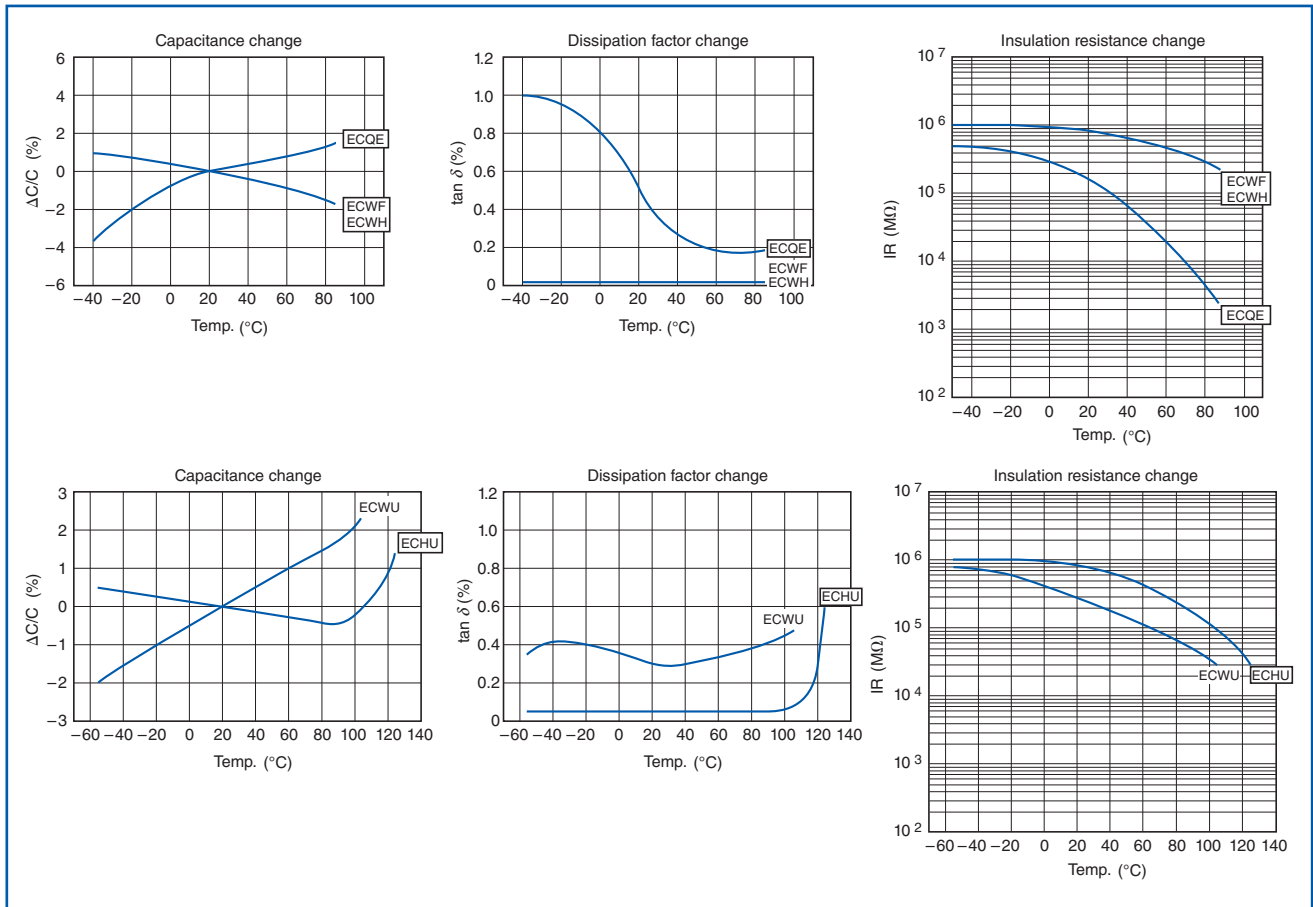

Frequency Characteristics

Typical curve

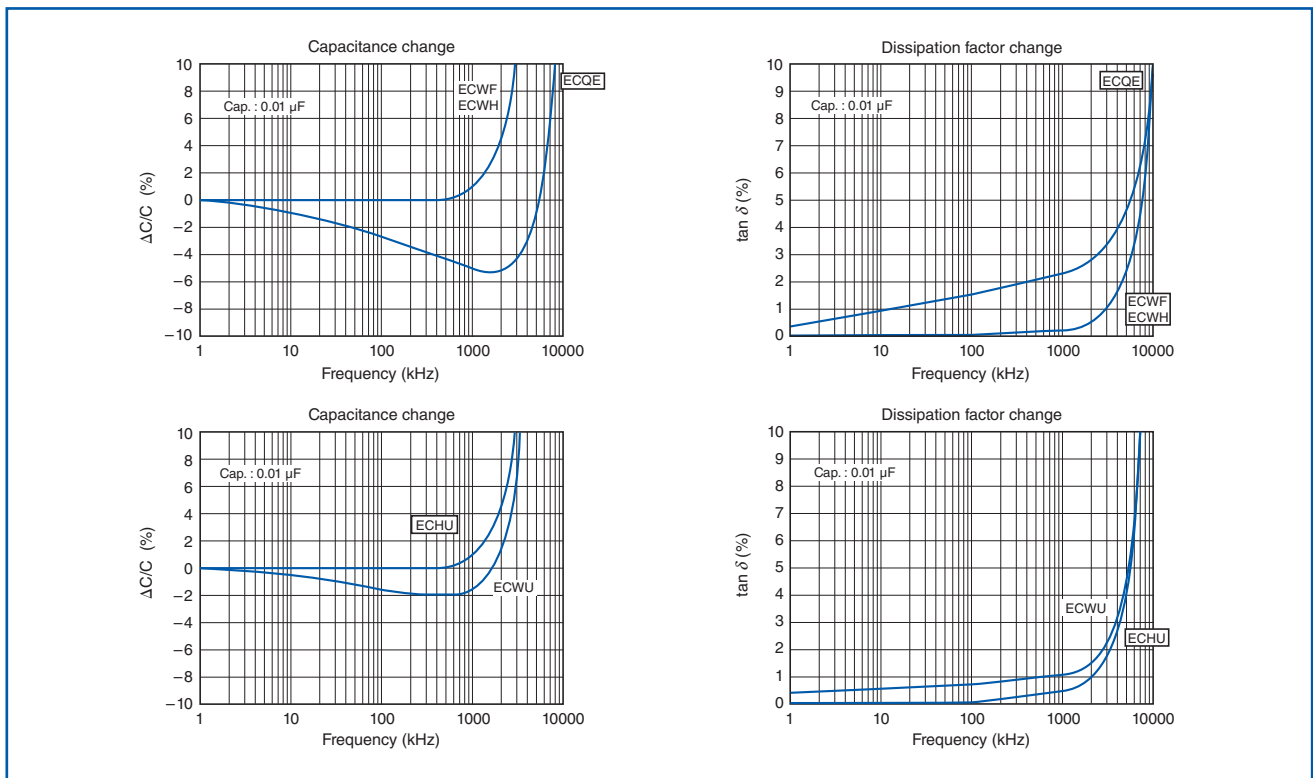

Dielectric	PPS						PEN						Thermoset resin					
Series	ECHU(X)			ECHU(C)			ECWU(C)				ECWU(C)V16		ECWU(X)		ECPU(A)			
Rated. volt	16 V.DC		50 V.DC*		100 V.DC		100 V.DC*		250 V.DC*		630 V.DC*		250 V.DC		100 V.DC		16 V.DC	
Category/Temp. range	-55 °C to +125 °C			-55 °C to +105 °C			-55 °C to +125 °C				-55 °C to +85 °C		-55 °C to +105 °C		-40 °C to +85 °C			
Cap. tol.	±2 %, ±5 %						±5 %, ±10 %				±5 %		±5 %		±20 %			
Soldering	Reflow						Reflow						Reflow					
Cap.	Size code	H	Size code	H	Size code	H	Size code	H	Size code	H	Size code	H	Size code	H	Size code	H		
0.00010	1608	0.7	2012	0.9														
0.00012	1608	0.7	2012	0.9														
0.00015	1608	0.7	2012	0.9														
0.00018	1608	0.7	2012	0.9														
0.00022	1608	0.7	2012	0.9														
0.00027	1608	0.7	2012	0.9														
0.00033	1608	0.7	2012	0.9														
0.00039	1608	0.7	2012	0.9														
0.00047	1608	0.7	2012	0.9														
0.00056	1608	0.7	2012	0.9														
0.00068	1608	0.7	2012	0.9														
0.00082	1608	0.7	2012	0.9														
0.0010	1608	0.7	2012	0.9					4833	1.4			4833	1.4	3216	1.1		
0.0012	1608	0.7	2012	0.9					4833	1.4			4833	1.4	3216	1.1		
0.0015	1608	0.7	2012	0.9					4833	1.4			4833	1.4	3216	1.1		
0.0018	1608	0.7	2012	0.9					4833	1.4			4833	1.4	3216	1.1		
0.0022	1608	0.7	2012	0.9					4833	1.4			4833	1.4	3216	1.1		
0.0027	1608	0.7	2012	0.9					4833	1.4			4833	1.4	3216	1.1		
0.0033	2012	0.9	3216	0.9					4833	1.4			4833	1.4	3216	1.5		
0.0039	2012	0.9	3216	0.9					4833	1.4			4833	1.4	3216	1.5		
0.0047	2012	0.9	3216	0.9					4833	1.4			4833	1.4	3216	1.5		
0.0056	2012	0.9	3216	0.9					4833	1.4			4833	1.4	3225	1.5		
0.0068	2012	0.9	3216	0.9					4833	1.4			4833	1.4	3225	1.5		
0.0082	2012	1.1	3216	1.1					4833	1.4			4833	1.4	3225	2.1		
0.010	2012	1.1	3216	1.1	4833	1.4			4833	1.4			4833	1.4	3225	2.1		
0.012	3216	0.9	3225	1.1	4833	1.4	4833	1.4	4833	1.4			4833	1.4				
0.015	3216	0.9	3225	1.1	4833	2.0	4833	1.4	4833	1.4			4833	1.4				
0.018	3216	0.9	3225	1.5	4833	2.0	4833	1.4	4833	2.0			4833	2.0				
0.022	3216	0.9	3225	1.5	4833	2.4	4833	1.4	4833	2.0	7163	3.6	4833	2.0				
0.027	3216	1.1	3225	1.5	4833	2.8	4833	1.4	4833	2.4	7163	4.1	4833	2.4				
0.033	3216	1.1	3225	2.1	6041	1.8	4833	1.4	4833	2.8	7163	5.1	4833	2.8				
0.039	3216	1.5	3225	2.1	6041	2.0	4833	1.4	6041	2.0			6041	2.0				
0.047	3216	1.5	4833	1.5	6041	2.4	4833	2.0	6041	2.4			6041	2.4				
0.056	3225	1.5	4833	1.5	6041	2.8	4833	2.0	6041	2.8			6041	2.8				
0.068	3225	1.5	4833	1.5	6041	3.2	4833	2.4	6041	3.2			6041	3.2				
0.082	3225	2.1	4833	2.1	7150	2.8	4833	2.8	6050	3.2			6050	3.2				
0.10	3225	2.1	4833	2.1	7150	3.0	6041	1.8	6050	3.8			6050	3.8		2012 1.0		
0.12			6041	1.9	7150	3.4	6041	2.4	6050	4.5			6050	4.5				
0.15			6041	1.9	7163	3.4	6041	2.8								3216 0.8		
0.18			6041	2.5	7163	4.0	7150	2.0										
0.22			6041	2.8	7163	4.8	7150	2.4								3216 0.8		
0.27							7150	2.9										
0.33							7150	3.5								3216 1.0		
0.39							7755	3.4										
0.47							7755	4.0								3216 1.4		
0.56							9863	3.0										
0.68							9863	3.6								3216 1.4		
0.82							9863	4.3										
1.0							9863	5.1								3225 1.4		

* Please confirm in the individual page because the specifications depend on the partial capacitance.

Stacked Metallized PPS Film Chip Capacitor

ECHU(X) series

Stacked metallized PPS film as dielectric with simple mold-less construction.



Features

- Small in size (Minimum size 1.6 mm × 0.8 mm)
- 85 °C, 85 %RH, W.V. × 1.0 for 500 hours
- For reflow soldering
- RoHS compliant

Recommended applications

- Time-constant
- Filtering
- Oscillation and resonance
- Audio circuit

Explanation of part number

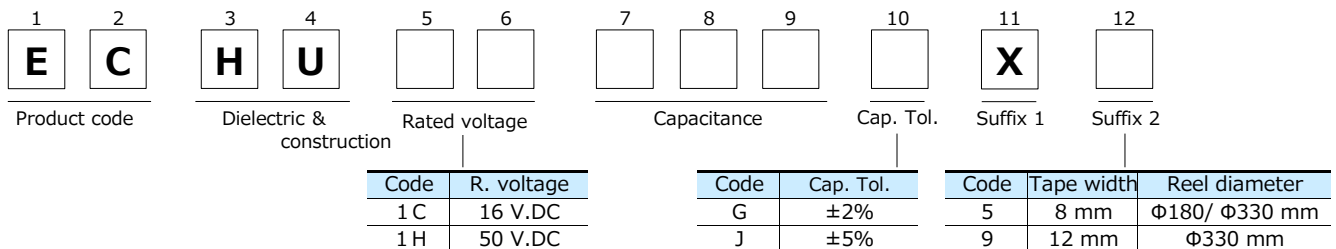

Specifications

Category temp. range (Including temperature-rise on unit surface)	-55 °C to +125 °C
Rated voltage	16 V.DC, 50 V.DC (50 V.DC : 0.12 μF or more : Derating or rated voltage by 1.25 % / °C at more than 105 °C)
Capacitance range	16 V.DC : 0.00010 μF to 0.10 μF (E12) 50 V.DC : 0.00010 μF to 0.22 μF (E12)
Capacitance tolerance	±2 % (G), ±5 % (J)
Dissipation factor (tan δ)	tan δ ≤ 0.6 % (20 °C, 1 kHz)
Withstand voltage	Between terminals : Rated voltage (V.DC) × 150 % 60 s
Insulation resistance (IR)	16 V.DC : IR ≥ 3000 MΩ (20 °C, 10 V.DC, 60 s) 50 V.DC : IR ≥ 3000 MΩ (20 °C, 50 V.DC, 60 s)
Soldering conditions	Reflow soldering : 260 °C max. and 95 sec max. at more than 220 °C (Temp. at capacitor surface)

* Please consult us for flow soldering.

* In case of applying voltage in alternating current (50 Hz or 60 Hz sine wave) to a capacitor with DC rated voltage, please refer to the page of "Permissible voltage (R.M.S) in alternating current corresponding to DC rated voltage".

Construction

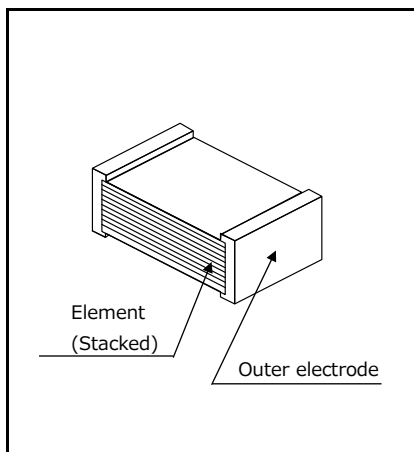

Dimensions

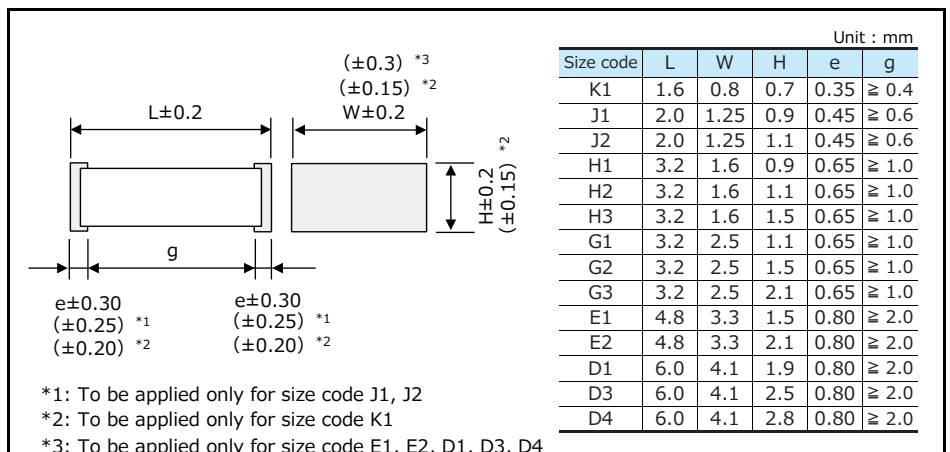

Taping specification for automatic mounting

■ Refer to the page of taping specifications

Rating · Dimensions · Quantity

■ Capacitance tolerance : ±2 %(G), ±5 %(J)

Capacitance (μF)	Rated voltage 16 V.DC					Rated voltage 50 V.DC							
	Part No.	Dimensions (mm)			Size code	Q'ty (PCS)	Part No.	Dimensions (mm)			Size code	Q'ty (PCS)	
		L	W	H				L	W	H			
0.00010	ECHU1C101□X5	1.6	0.8	0.7	K1	4000	ECHU1H101□X5	2.0	1.25	0.9	J1	3000	
0.00012	ECHU1C121□X5	1.6	0.8	0.7	K1		ECHU1H121□X5	2.0	1.25	0.9	J1		
0.00015	ECHU1C151□X5	1.6	0.8	0.7	K1		ECHU1H151□X5	2.0	1.25	0.9	J1		
0.00018	ECHU1C181□X5	1.6	0.8	0.7	K1		ECHU1H181□X5	2.0	1.25	0.9	J1		
0.00022	ECHU1C221□X5	1.6	0.8	0.7	K1		ECHU1H221□X5	2.0	1.25	0.9	J1		
0.00027	ECHU1C271□X5	1.6	0.8	0.7	K1		ECHU1H271□X5	2.0	1.25	0.9	J1		
0.00033	ECHU1C331□X5	1.6	0.8	0.7	K1		ECHU1H331□X5	2.0	1.25	0.9	J1		
0.00039	ECHU1C391□X5	1.6	0.8	0.7	K1		ECHU1H391□X5	2.0	1.25	0.9	J1		
0.00047	ECHU1C471□X5	1.6	0.8	0.7	K1		ECHU1H471□X5	2.0	1.25	0.9	J1		
0.00056	ECHU1C561□X5	1.6	0.8	0.7	K1		ECHU1H561□X5	2.0	1.25	0.9	J1		
0.00068	ECHU1C681□X5	1.6	0.8	0.7	K1		ECHU1H681□X5	2.0	1.25	0.9	J1		
0.00082	ECHU1C821□X5	1.6	0.8	0.7	K1		ECHU1H821□X5	2.0	1.25	0.9	J1		
0.0010	ECHU1C102□X5	1.6	0.8	0.7	K1		ECHU1H102□X5	2.0	1.25	0.9	J1		
0.0012	ECHU1C122□X5	1.6	0.8	0.7	K1		ECHU1H122□X5	2.0	1.25	0.9	J1		
0.0015	ECHU1C152□X5	1.6	0.8	0.7	K1	ECHU1H152□X5	2.0	1.25	0.9	J1			
0.0018	ECHU1C182□X5	1.6	0.8	0.7	K1	ECHU1H182□X5	2.0	1.25	0.9	J1			
0.0022	ECHU1C222□X5	1.6	0.8	0.7	K1	ECHU1H222□X5	2.0	1.25	0.9	J1			
0.0027	ECHU1C272□X5	1.6	0.8	0.7	K1	ECHU1H272□X5	2.0	1.25	0.9	J1			
0.0033	ECHU1C332□X5	2.0	1.25	0.9	J1	3000	ECHU1H332□X5	3.2	1.6	0.9	H1	2000	
0.0039	ECHU1C392□X5	2.0	1.25	0.9	J1		ECHU1H392□X5	3.2	1.6	0.9	H1		
0.0047	ECHU1C472□X5	2.0	1.25	0.9	J1		ECHU1H472□X5	3.2	1.6	0.9	H1		
0.0056	ECHU1C562□X5	2.0	1.25	0.9	J1		ECHU1H562□X5	3.2	1.6	0.9	H1		
0.0068	ECHU1C682□X5	2.0	1.25	0.9	J1		ECHU1H682□X5	3.2	1.6	0.9	H1		
0.0082	ECHU1C822□X5	2.0	1.25	1.1	J2		ECHU1H822□X5	3.2	1.6	1.1	H2		
0.010	ECHU1C103□X5	2.0	1.25	1.1	J2		ECHU1H103□X5	3.2	1.6	1.1	H2		
0.012	ECHU1C123□X5	3.2	1.6	0.9	H1		ECHU1H123□X5	3.2	2.5	1.1	G1		
0.015	ECHU1C153□X5	3.2	1.6	0.9	H1		ECHU1H153□X5	3.2	2.5	1.1	G1		
0.018	ECHU1C183□X5	3.2	1.6	0.9	H1		ECHU1H183□X5	3.2	2.5	1.5	G2		
0.022	ECHU1C223□X5	3.2	1.6	0.9	H1		ECHU1H223□X5	3.2	2.5	1.5	G2		
0.027	ECHU1C273□X5	3.2	1.6	1.1	H2		ECHU1H273□X5	3.2	2.5	1.5	G2		
0.033	ECHU1C333□X5	3.2	1.6	1.1	H2		ECHU1H333□X5	3.2	2.5	2.1	G3		
0.039	ECHU1C393□X5	3.2	1.6	1.5	H3		2000	ECHU1H393□X5	3.2	2.5	2.1		G3
0.047	ECHU1C473□X5	3.2	1.6	1.5	H3	ECHU1H473□X9		4.8	3.3	1.5	E1		
0.056	ECHU1C563□X5	3.2	2.5	1.5	G2	ECHU1H563□X9		4.8	3.3	1.5	E1		
0.068	ECHU1C683□X5	3.2	2.5	1.5	G2	ECHU1H683□X9		4.8	3.3	1.5	E1		
0.082	ECHU1C823□X5	3.2	2.5	2.1	G3	ECHU1H823□X9		4.8	3.3	2.1	E2		
0.10	ECHU1C104□X5	3.2	2.5	2.1	G3	ECHU1H104□X9		4.8	3.3	2.1	E2		
0.12						ECHU1H124□X9		6.0	4.1	1.9	D1	2000	
0.15						ECHU1H154□X9		6.0	4.1	1.9	D1		
0.18						ECHU1H184□X9		6.0	4.1	2.5	D3		
0.22						ECHU1H224□X9		6.0	4.1	2.8	D4		

* □ : Capacitance tolerance code

Recommended for land dimensions

Unit : mm

Size code	Land dimensions		
	Reflow soldering		
	A	B	C
K1	0.6	2.0	0.7
J1, J2	0.8	2.4	1.1
H1, H2, H3	1.8	3.6	1.4
G1, G2, G3	1.8	3.6	2.3
E1, E2	3.0	5.6	3.0
D1, D3, D4	4.0	7.0	3.8

* It is not warrantable that you can mount the capacitor without trouble under all the mounting condition when "Recommender for Land dimensions" is adopted.

Stacked Metallized PPS Film Chip Capacitor

ECHU(C) series

**Stacked metallized PPS film as dielectric with
simple mold-less construction.**



Features

- Small in size
- Low loss and excellent frequency characteristics
- For reflow soldering
- RoHS compliant

Recommended applications

- Time-constant
- Filtering
- Oscillation and resonance
- Resonance circuit for LCD backlight inverter unit

Explanation of part number

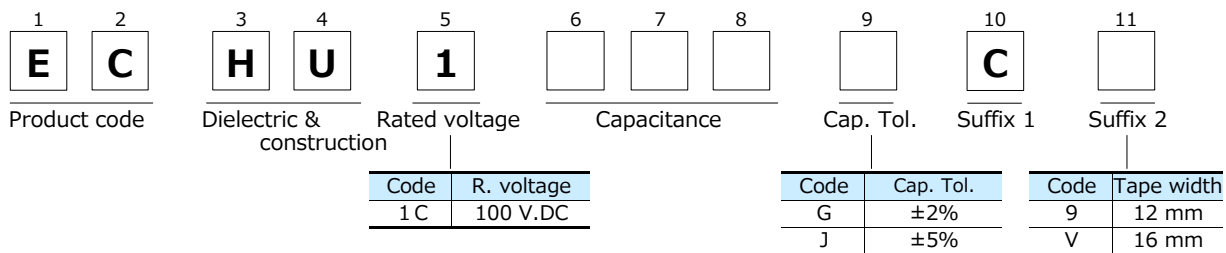

Specifications

Category temp. range (Including temperature-rise on unit surface)	-55 °C to +105 °C
Rated voltage	100 V.DC
Capacitance range	0.010 μF to 0.22 μF (E12)
Capacitance tolerance	±2 % (G), ±5 % (J)
Dissipation factor (tan δ)	tan δ ≤ 0.6 % (20 °C, 1 kHz)
Withstand voltage	Between terminals : Rated voltage (V.DC) × 150 % 60 s
Insulation resistance (IR)	IR ≥ 3000 MΩ (20 °C, 10 V.DC, 60 s)
Soldering conditions	Reflow soldering : 260 °C max. and 95 sec max. at more than 220 °C (Temp. at capacitor surface)

* In case of applying voltage in alternating current (50 Hz or 60 Hz sine wave) to a capacitor with DC rated voltage, please refer to the page of "Permissible voltage (R.M.S) in alternating current corresponding to DC rated voltage".

Construction

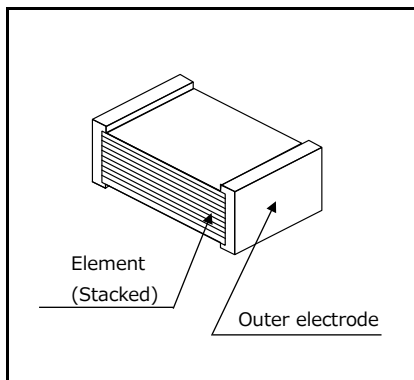

Dimensions

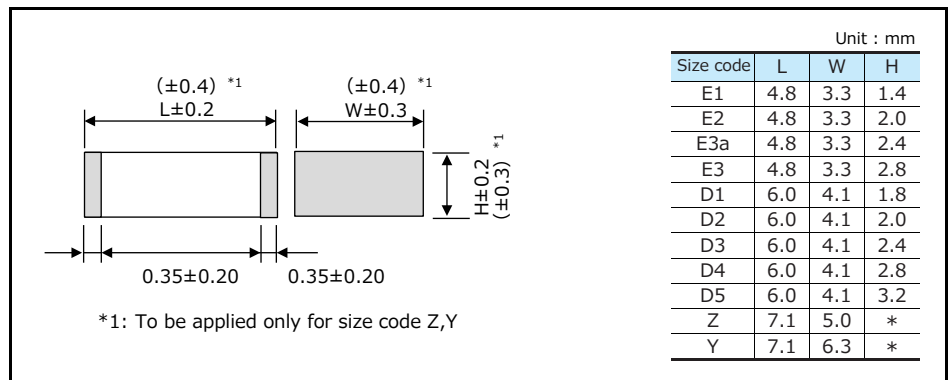

Taping specification for automatic mounting

- Refer to the page of taping specifications

Rating · Dimensions · Quantity

- Capacitance tolerance : $\pm 2\%$ (G), $\pm 5\%$ (J)

Capacitance (μF)	Part No.	Rated voltage 100 V.DC			Size code	Q'ty (PCS)
		Dimensions (mm)				
		L	W	H		
0.010	ECHU1103□C9	4.8	3.3	1.4	E1	3000
0.012	ECHU1123□C9	4.8	3.3	1.4	E1	
0.015	ECHU1153□C9	4.8	3.3	2.0	E2	
0.018	ECHU1183□C9	4.8	3.3	2.0	E2	
0.022	ECHU1223□C9	4.8	3.3	2.4	E3a	2000
0.027	ECHU1273□C9	4.8	3.3	2.8	E3	
0.033	ECHU1333□C9	6.0	4.1	1.8	D1	3000
0.039	ECHU1393□C9	6.0	4.1	2.0	D2	
0.047	ECHU1473□C9	6.0	4.1	2.4	D3	2000
0.056	ECHU1563□C9	6.0	4.1	2.8	D4	
0.068	ECHU1683□C9	6.0	4.1	3.2	D5	
0.082	ECHU1823□C9	7.1	5.0	2.8	Z	
0.10	ECHU1104□C9	7.1	5.0	3.0	Z	1500
0.12	ECHU1124□C9	7.1	5.0	3.4	Z	
0.15	ECHU1154□CV	7.1	6.3	3.4	Y	1000
0.18	ECHU1184□CV	7.1	6.3	4.0	Y	
0.22	ECHU1224□CV	7.1	6.3	4.8	Y	

* □ : Capacitance tolerance code

Recommended for land dimensions

The diagram shows two rectangular electrodes on a substrate. The distance between the inner edges of the electrodes is labeled 'Land'. Dimension 'A' is the width of one electrode, 'B' is the total width including both electrodes and the land, and 'C' is the height of the electrodes. An arrow points to one of the electrodes with the label 'Electrode'.

Unit : mm

Size code	Land dimensions		
	Reflow soldering		
	A	B	C
E1, E2, E3a, E3	2.6	6.6	3.0
D1, D2, D3, D4, D5	3.8	7.8	3.8
Z	4.5	9.0	4.6
Y	4.5	9.0	5.7

* It is not warrantable that you can mount the capacitor without trouble under all the mounting condition when "Recommender for Land dimensions" is adopted.

Stacked Metallized PEN Film Chip Capacitor

ECWU(X) series

Stacked metallized PEN film as dielectric with simple mold-less construction.

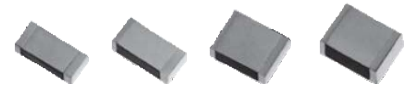

Features

- Small in size
- 85 °C, 85 %RH, W.V. × 1.0 for 500 hours
- For reflow soldering
- RoHS compliant

Recommended applications

- General purpose (Coupling, By-pass)

Explanation of part number

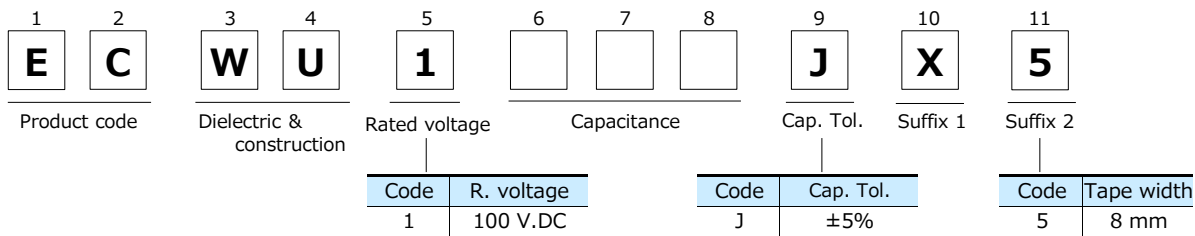

Specifications

Category temp. range (Including temperature-rise on unit surface)	-55 °C to +105 °C
Rated voltage	100 V.DC
Capacitance range	0.0010 μF to 0.010 μF (E12)
Capacitance tolerance	±5 %(J)
Dissipation factor (tan δ)	tan δ ≤ 1.0 % (20 °C, 1 kHz)
Withstand voltage	Between terminals : Rated voltage (V.DC) × 150 % 60 s
Insulation resistance (IR)	IR ≥ 3000 MΩ (20 °C, 100 V.DC, 60 s)
Soldering conditions	Reflow soldering : 250 °C max. and 60 sec max. at more than 220 °C (Temp. at capacitor surface)

* In case of applying voltage in alternating current (50 Hz or 60 Hz sine wave) to a capacitor with DC rated voltage, please refer to the page of "Permissible voltage (R.M.S) in alternating current corresponding to DC rated voltage".

Construction

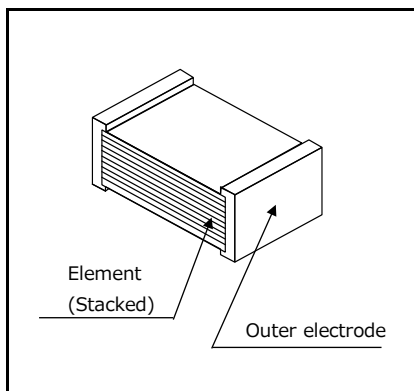

Dimensions

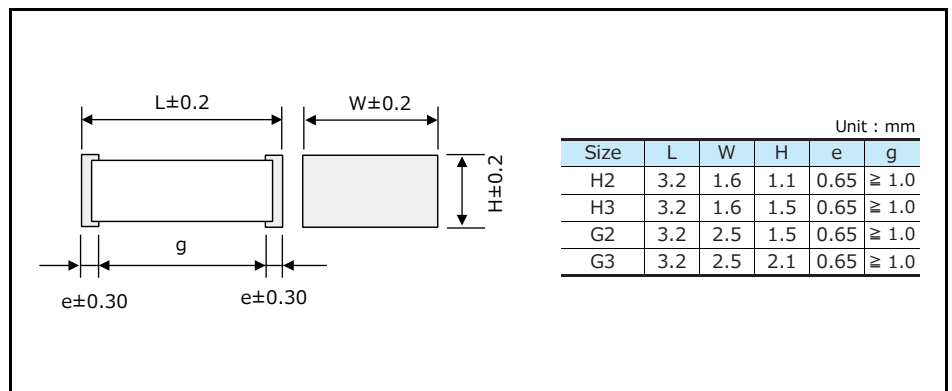

Taping specification for automatic mounting

- Refer to the page of taping specifications

Rating · Dimensions · Quantity

- Capacitance tolerance : $\pm 5 \%$ (J)

Capacitance (μF)	Part No.	Rated voltage 100 V.DC			Size code	Q'ty (PCS)
		Dimensions (mm)				
		L	W	H		
0.0010	ECWU1102JX5	3.2	1.6	1.1	H2	3000
0.0012	ECWU1122JX5	3.2	1.6	1.1	H2	
0.0015	ECWU1152JX5	3.2	1.6	1.1	H2	
0.0018	ECWU1182JX5	3.2	1.6	1.1	H2	
0.0022	ECWU1222JX5	3.2	1.6	1.1	H2	
0.0027	ECWU1272JX5	3.2	1.6	1.1	H2	
0.0033	ECWU1332JX5	3.2	1.6	1.5	H3	2000
0.0039	ECWU1392JX5	3.2	1.6	1.5	H3	
0.0047	ECWU1472JX5	3.2	1.6	1.5	H3	
0.0056	ECWU1562JX5	3.2	2.5	1.5	G2	
0.0068	ECWU1682JX5	3.2	2.5	1.5	G2	
0.0082	ECWU1822JX5	3.2	2.5	2.1	G3	
0.010	ECWU1103JX5	3.2	2.5	2.1	G3	

* cap. $\geq 0.012 \mu\text{F}$: Please use 100 V.DC rating of ECWU(C)

Recommended for land dimensions

Unit : mm

Size code	Land dimensions		
	Reflow soldering		
	A	B	C
H2, H3	1.8	3.6	1.4
G2, G3	1.8	3.6	2.3

* It is not warrantable that you can mount the capacitor without trouble under all the mounting condition when "Recommender for Land dimensions" is adopted.

Stacked Metallized PEN Film Chip Capacitor

ECWU(C) series

Stacked metallized PEN film as dielectric with simple mold-less construction.



Features

- Small in size
- For reflow soldering
- RoHS compliant

Recommended applications

- General purpose (Coupling, By-pass)

Explanation of part number

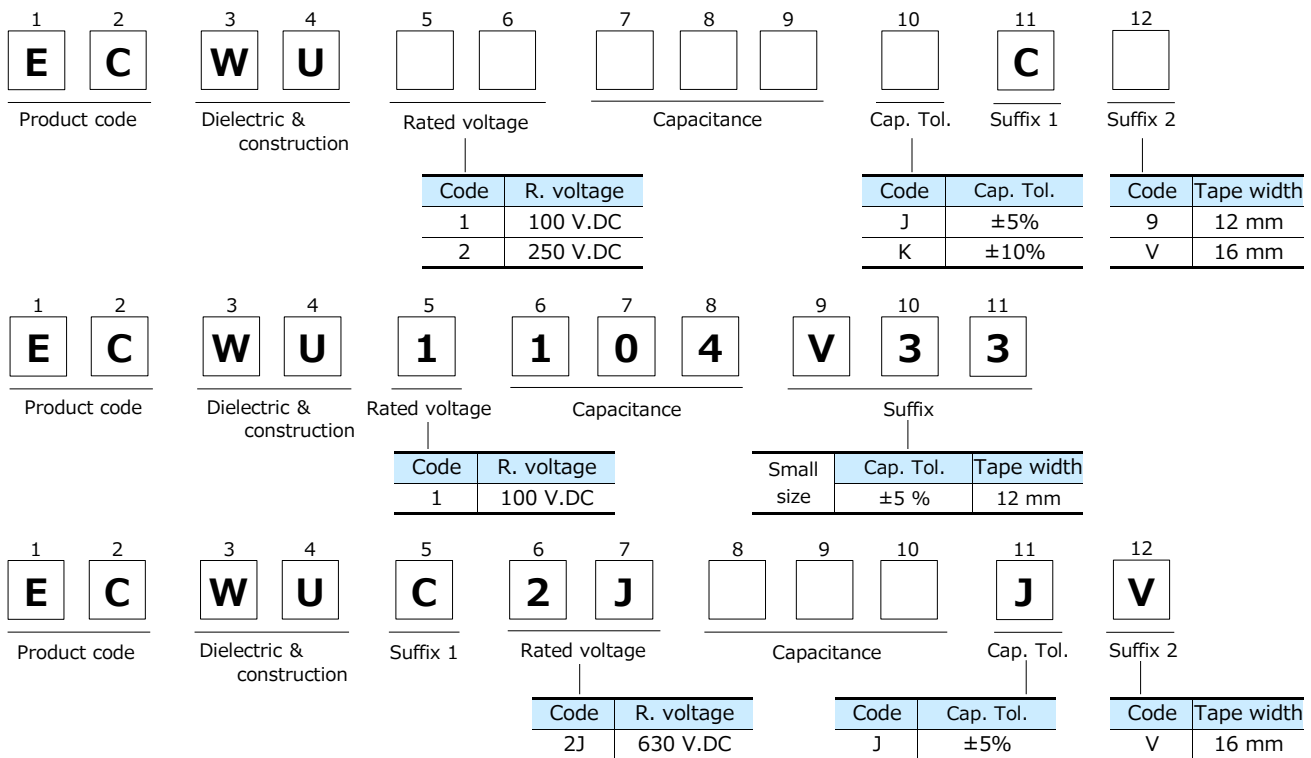

Specifications

Category temp. range (Including temperature-rise on unit surface)	-55 °C to +125 °C	
Rated voltage	100 V.DC, 250 V.DC, 630 V.DC (Derating of rated voltage by 1.25 %/°C more than 85 °C)	
Capacitance range	100 V.DC	0.012 μF to 1.0 μF (E12)
	250 V.DC	0.0010 μF to 0.12 μF (E12)
	630 V.DC	0.022 μF, 0.027 μF, 0.033 μF
Capacitance tolerance	100 V.DC	±5 % (J), ±10 % (K) (C ≥ 0.18 μF : ±10 % (K) Only)
	250 V.DC	±5 % (J), ±10 % (K)
	630 V.DC	±5 % (J)
Dissipation factor (tan δ)	tan δ ≤ 1.0 % (20 °C, 1 kHz)	
Withstand voltage	Between terminals : Rated voltage (V.DC) × 150 % 60 s	
Insulation resistance (IR)	C ≤ 0.33 μF	100 V.DC, 250 V.DC, 630 V.DC : IR ≥ 3000 MΩ (20 °C, 100 V.DC, 60 s)
	C > 0.33 μF	100 V.DC : IR ≥ 1000 MΩ·μF (20 °C, 100 V.DC, 60 s)
Soldering conditions	100 V.DC	Reflow soldering : 250 °C max. and 60 s max. at more than 220 °C
	250 V.DC	(Temp. at capacitor surface)
	630 V.DC	Reflow soldering : 250 °C max. and 60 s to 150 s. at more than 217 °C
		(Temp. at cap. surface)

* In case of applying voltage in alternating current (50 Hz or 60 Hz sine wave) to a capacitor with DC rated voltage, please refer to the page of "Permissible voltage (R.M.S) in alternating current corresponding to DC rated voltage".

* Please consult us for capacitance range between 0.15 μF and 1.0 μF. (250 V.DC)

Construction

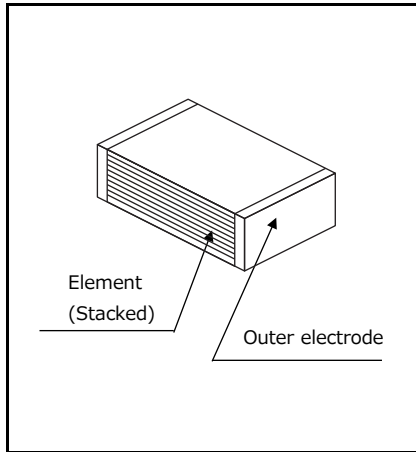

Dimensions

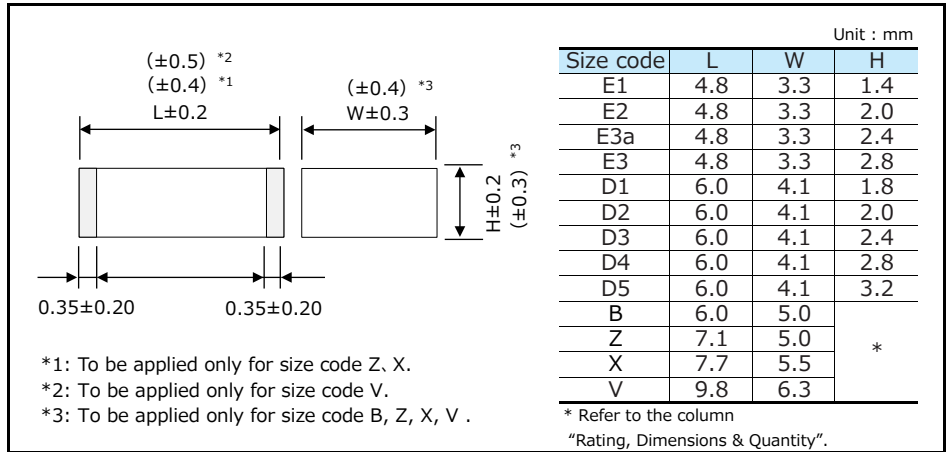

Taping specification for automatic mounting

- Refer to the page of taping specifications

Rating · Dimensions · Quantity

- Capacitance tolerance : ±5 %(J), ±10 %(K)

Capacitance (μF)	Rated voltage 100 V.DC					Rated voltage 250 V.DC									
	Part No.	Dimensions (mm)			Size code	Q'ty (PCS)	Part No.	Dimensions (mm)			Size code	Q'ty (PCS)			
		L	W	H				L	W	H					
0.0010	Please use 0.001 μF to 0.01 μF rating ECWU(X)	ECWU2102□C9	4.8	3.3	1.4	E1	3000	ECWU2103□C9	4.8	3.3	1.4	E1			
0.0012			ECWU2122□C9	4.8	3.3	1.4			E1						
0.0015			ECWU2152□C9	4.8	3.3	1.4			E1						
0.0018			ECWU2182□C9	4.8	3.3	1.4			E1						
0.0022			ECWU2222□C9	4.8	3.3	1.4			E1						
0.0027			ECWU2272□C9	4.8	3.3	1.4			E1						
0.0033			ECWU2332□C9	4.8	3.3	1.4			E1						
0.0039			ECWU2392□C9	4.8	3.3	1.4			E1						
0.0047			ECWU2472□C9	4.8	3.3	1.4			E1						
0.0056			ECWU2562□C9	4.8	3.3	1.4			E1						
0.0068			ECWU2682□C9	4.8	3.3	1.4			E1						
0.0082			ECWU2822□C9	4.8	3.3	1.4			E1						
0.010			ECWU2103□C9	4.8	3.3	1.4			E1						
0.012			ECWU1123□C9	4.8	3.3	1.4			E1	2000	ECWU2123□C9	4.8	3.3	1.4	E1
0.015			ECWU1153□C9	4.8	3.3	1.4			E1		ECWU2153□C9	4.8	3.3	1.4	E1
0.018			ECWU1183□C9	4.8	3.3	1.4			E1		ECWU2183□C9	4.8	3.3	2.0	E2
0.022	ECWU1223□C9	4.8	3.3	1.4	E1	ECWU2223□C9	4.8	3.3	2.0		E2				
0.027	ECWU1273□C9	4.8	3.3	1.4	E1	ECWU2273□C9	4.8	3.3	2.4		E3a				
0.033	ECWU1333□C9	4.8	3.3	1.4	E1	ECWU2333□C9	4.8	3.3	2.8		E3				
0.039	ECWU1393□C9	4.8	3.3	1.4	E1	ECWU2393□C9	6.0	4.1	2.0		D2				
0.047	ECWU1473□C9	4.8	3.3	2.0	E2	ECWU2473□C9	6.0	4.1	2.4		D3				
0.056	ECWU1563□C9	4.8	3.3	2.0	E2	ECWU2563□C9	6.0	4.1	2.8		D4				
0.068	ECWU1683□C9	4.8	3.3	2.4	E3a	ECWU2683□C9	6.0	4.1	3.2		D5				
0.082	ECWU1823□C9	4.8	3.3	2.8	E3	ECWU2823□C9	6.0	5.0	3.2		B				
0.10	ECWU1104□C9	6.0	4.1	1.8	D1	1500	ECWU2104□C9	6.0	5.0		3.8	B			
	ECWU1104V33	4.8	3.3	2.8	E3										
0.12	ECWU1124□C9	6.0	4.1	2.4	D3	ECWU2124□C9	6.0	5.0	4.5		B				
0.15	ECWU1154□C9	6.0	4.1	2.8	D4										
0.18	ECWU1184KC9	7.1	5.0	2.0	Z	1500									
0.22	ECWU1224KC9	7.1	5.0	2.4	Z										
0.27	ECWU1274KC9	7.1	5.0	2.9	Z										
0.33	ECWU1334KC9	7.1	5.0	3.5	Z										
0.39	ECWU1394KCV	7.7	5.5	3.4	x	1000									
0.47	ECWU1474KCV	7.7	5.5	4.0	x										
0.56	ECWU1564KCV	9.8	6.3	3.0	V										
0.68	ECWU1684KCV	9.8	6.3	3.6	V										
0.82	ECWU1824KCV	9.8	6.3	4.3	V										
1.0	ECWU1105KCV	9.8	6.3	5.1	V										

* □ : Capacitance tolerance

Rating · Dimensions · Quantity

■ Capacitance tolerance : ±5 %(J)

Capacitance (μF)	Rated voltage 630 V.DC					Q'ty (PCS)
	Part No.	Dimensions (mm)			Size code	
		L	W	H		
0.022	ECWUC2J223JV	7.1	6.3	3.6	Y	1000
0.027	ECWUC2J273JV	7.1	6.3	4.1	Y	
0.033	ECWUC2J333JV	7.1	6.3	5.1	Y	

Recommended for land dimensions

The diagram shows two vertical electrodes with a central land. Dimension 'U' is the height of the electrodes. Dimension 'A' is the width of the land. Dimension 'B' is the distance between the inner edges of the electrodes. Dimension 'C' is the distance between the outer edges of the electrodes. The label 'Electrode' points to the top of the right electrode.

Unit : mm

Size code	Land dimensions		
	Reflow soldering		
	A	B	C
E1, E2, E3a, E3	2.6	6.6	3.0
D1, D2, D3, D4, D5	3.8	7.8	3.8
B	3.8	7.8	4.6
Z	4.5	9.0	4.6
Y	4.5	9.0	5.7
X	5.1	9.7	5.0
V	7.2	11.9	5.7

* It is not warrantable that you can mount the capacitor without trouble under all the mounting condition when "Recommender for Land dimensions" is adopted.

Stacked Metallized PEN Film Chip Capacitor

ECWU(V16) series

**Stacked metallized PEN film dielectric with
simple mold-less construction for DC Blocking for xDSL.**



Features

- Small in size
- For reflow soldering
- RoHS compliant

Recommended applications

- DC Blocking for xDSL

Explanation of part number

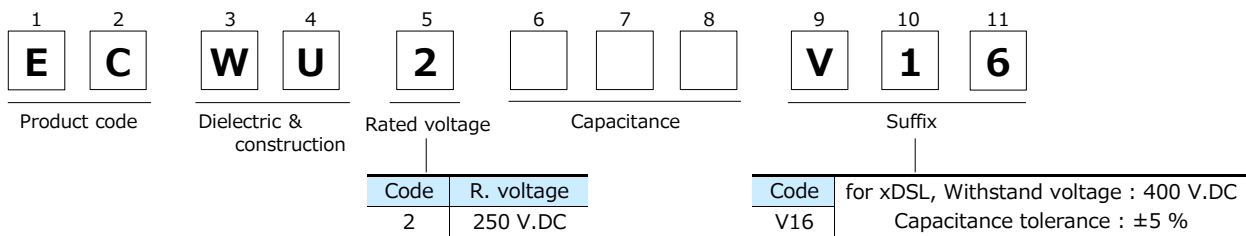

Specifications

Category temp. range (Including temperature-rise on unit surface)	-55 °C to +85 °C
Rated voltage	250 V.DC
Capacitance range	0.0010 μF to 0.12 μF (E12)
Capacitance tolerance	±5 %(J)
Dissipation factor (tan δ)	tan δ ≤ 1.0 % (20 °C, 1 kHz)
Withstand voltage	Between terminals : 400 V.DC, 60 s
Insulation resistance (IR)	IR ≥ 3000 MΩ (20 °C, 100 V.DC, 60 s)
Soldering conditions	Reflow soldering : 250 °C max. and 60 s max. at more than 220 °C (Temp. at capacitor surface)

* In case of applying voltage in alternating current (50 Hz or 60 Hz sine wave) to a capacitor with DC rated voltage, please refer to the page of "Permissible voltage (R.M.S) in alternating current corresponding to DC rated voltage".

Construction

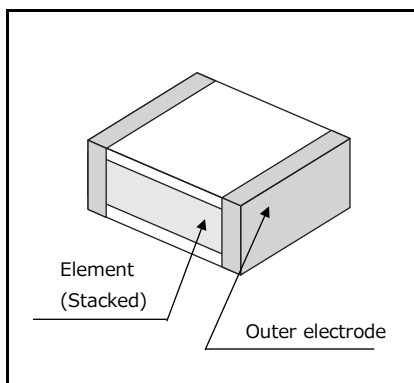

Dimensions

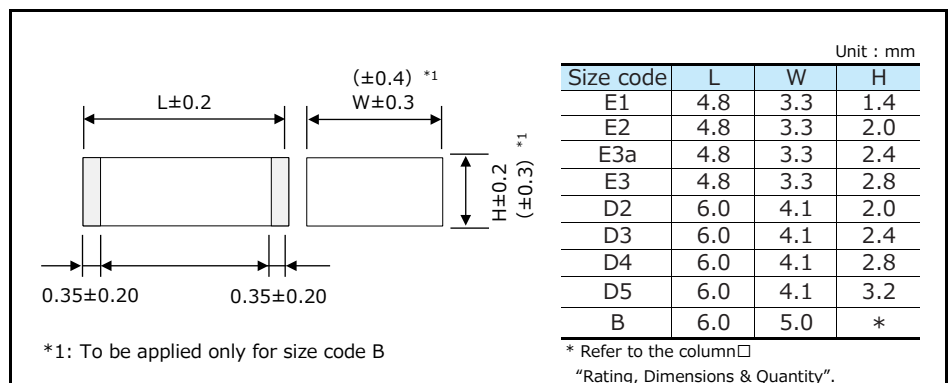

Taping specification for automatic mounting

- Refer to the page of taping specifications

Rating · Dimensions · Quantity

- Capacitance tolerance : ±5 %(J)

Capacitance (μF)	Part No.	Rated voltage 250 V.DC			Size code	Q'ty (PCS)
		Dimensions (mm)				
		L	W	H		
0.0010	ECWU2102V16	4.8	3.3	1.4	E1	3000
0.0012	ECWU2122V16	4.8	3.3	1.4	E1	
0.0015	ECWU2152V16	4.8	3.3	1.4	E1	
0.0018	ECWU2182V16	4.8	3.3	1.4	E1	
0.0022	ECWU2222V16	4.8	3.3	1.4	E1	
0.0027	ECWU2272V16	4.8	3.3	1.4	E1	
0.0033	ECWU2332V16	4.8	3.3	1.4	E1	
0.0039	ECWU2392V16	4.8	3.3	1.4	E1	
0.0047	ECWU2472V16	4.8	3.3	1.4	E1	
0.0056	ECWU2562V16	4.8	3.3	1.4	E1	
0.0068	ECWU2682V16	4.8	3.3	1.4	E1	
0.0082	ECWU2822V16	4.8	3.3	1.4	E1	
0.010	ECWU2103V16	4.8	3.3	1.4	E1	
0.012	ECWU2123V16	4.8	3.3	1.4	E1	
0.015	ECWU2153V16	4.8	3.3	1.4	E1	
0.018	ECWU2183V16	4.8	3.3	2.0	E2	
0.022	ECWU2223V16	4.8	3.3	2.0	E2	
0.027	ECWU2273V16	4.8	3.3	2.4	E3a	2000
0.033	ECWU2333V16	4.8	3.3	2.8	E3	2000
0.039	ECWU2393V16	6.0	4.1	2.0	D2	3000
0.047	ECWU2473V16	6.0	4.1	2.4	D3	2000
0.056	ECWU2563V16	6.0	4.1	2.8	D4	
0.068	ECWU2683V16	6.0	4.1	3.2	D5	
0.082	ECWU2823V16	6.0	5.0	3.2	B	1500
0.10	ECWU2104V16	6.0	5.0	3.8	B	
0.12	ECWU2124V16	6.0	5.0	4.5	B	

Recommended for land dimensions

The diagram shows a top-down view of a capacitor with two electrodes. Dimension L is the length, W is the width, and H is the height. Dimension A is the distance between the inner edges of the electrodes, and B is the distance between the outer edges. Dimension C is the height of the capacitor body. The area between the electrodes is labeled 'Land'.

Unit : mm

Size code	Land dimensions		
	Reflow soldering		
	A	B	C
E1, E2, E3a, E3	2.6	6.6	3.0
D2, D3, D4, D5	3.8	7.8	3.8
B	3.8	7.8	4.6

* It is not warrantable that you can mount the capacitor without trouble under all the mounting condition when "Recommender for Land dimensions" is adopted.

Stacked Metallized Plastic Film Chip Capacitor

ECPU(A) series

Stacked dielectric and inner electrode with simple mold-less construction.

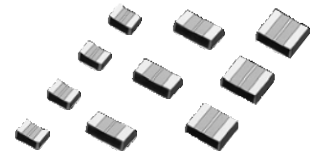

Features

- Low ESR
- Small size & large capacitance
- For reflow soldering
- RoHS compliant

Recommended applications

- Noise suppressor circuit
- Audio circuit

Explanation of part number

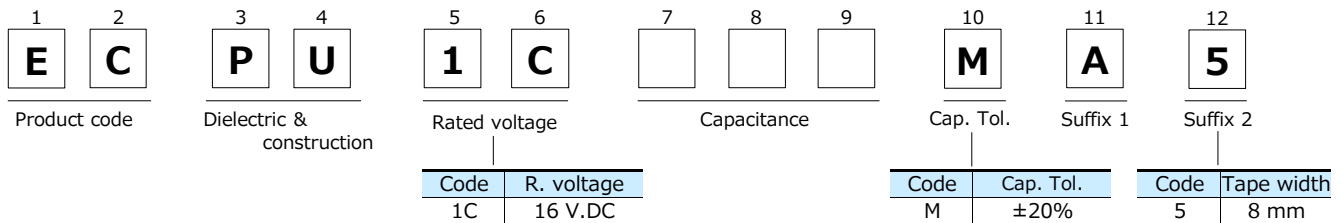

Specifications

Category temp. range (Including temperature-rise on unit surface)	-40 °C to +85 °C	
Rated voltage	16 V.DC	
Capacitance range	0.10 μF to 1.0 μF (E6)	
Capacitance tolerance	±20 % (M)	
Dissipation factor (tan δ)	tan δ ≤ 1.5 % (20 °C, 1 kHz)	
Withstand voltage	Between terminals : Rated voltage (V.DC) × 150 % 60 s	
Insulation resistance (IR)	C ≤ 0.33 μF	IR ≥ 1000 MΩ (20 °C, 10 V.DC, 60 s)
	C > 0.33 μF	IR ≥ 300 MΩ·μF (20 °C, 10 V.DC, 60 s)
Soldering conditions	Reflow soldering : 240 °C max. and 30 sec max. at more than 220 °C (Temp. at capacitor surface)	

* In case of applying voltage in alternating current (50 Hz or 60 Hz sine wave) to a capacitor with DC rated voltage, please refer to the page of "Permissible voltage (R.M.S) in alternating current corresponding to DC rated voltage".

Construction

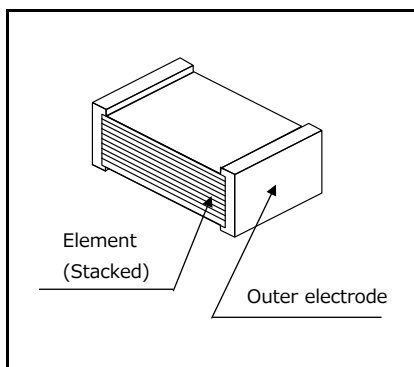

Dimensions

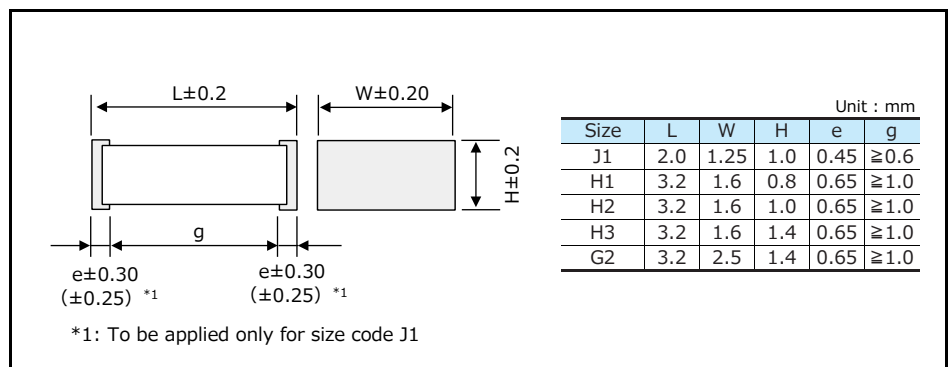

Taping specification for automatic mounting

- Refer to the page of taping specifications

Rating · Dimensions · Quantity

- Capacitance tolerance : $\pm 20\%$ (M)

Capacitance (μF)	Part No.	Rated voltage 16 V.DC			Size code	Q'ty (PCS)
		Dimensions (mm)				
		L	W	H		
0.10	ECPU1C104MA5	2.0	1.25	1.0	J1	3000
0.15	ECPU1C154MA5	3.2	1.6	0.8	H1	
0.22	ECPU1C224MA5	3.2	1.6	0.8	H1	
0.33	ECPU1C334MA5	3.2	1.6	1.0	H2	
0.47	ECPU1C474MA5	3.2	1.6	1.4	H3	2000
0.68	ECPU1C684MA5	3.2	1.6	1.4	H3	
1.00	ECPU1C105MA5	3.2	2.5	1.4	G2	

Recommended for land dimensions

The diagram shows two vertical rectangular electrodes. The distance between the inner edges of the electrodes is labeled 'Land'. The length of the electrodes is 'L', the width is 'W', and the height is 'H'. Dimension 'A' is the distance from the left edge of the left electrode to the right edge of the right electrode. Dimension 'B' is the distance from the left edge of the left electrode to the left edge of the right electrode. Dimension 'C' is the height of the electrodes.

Unit : mm

Size code	Land dimensions		
	Reflow soldering		
	A	B	C
J1	0.8	2.4	1.1
H1	1.8	3.6	1.4
H2	1.8	3.6	1.4
H3	1.8	3.6	1.4
G2	1.8	3.6	2.3

* It is not warrantable that you can mount the capacitor without trouble under all the mounting condition when "Recommender for Land dimensions" is adopted.

Metallized Polyester Film Capacitor

Series : **ECQE(F)**

Non-inductive construction using metallized Polyester film with flame retardant epoxy resin coating



Features

- Self-healing property
- Excellent electrical characteristics
- Flame retardant epoxy resin coating
- RoHS directive compliant

Recommended applications

- General purpose usage
 - * Please contact us when applications are CDI , ignitor etc.

Explanation of part number

1	2	3	4	5	6	7	8	9	10	11	12																																
E	C	Q	E							F																																	
Product code		Dielectric & construction		Rated voltage		Capacitance			Cap. Tol.	Suffix	Suffix																																
				<table border="1"> <tr> <td>1</td> <td>100 V.DC</td> <td>10</td> <td>1000 V.DC</td> </tr> <tr> <td>2</td> <td>250 V.DC</td> <td>12</td> <td>1250 V.DC</td> </tr> <tr> <td>4</td> <td>400 V.DC</td> <td>1A</td> <td>125 V.AC</td> </tr> <tr> <td>6</td> <td>630 V.DC</td> <td>2A</td> <td>250 V.AC</td> </tr> </table>		1	100 V.DC	10	1000 V.DC	2	250 V.DC	12	1250 V.DC	4	400 V.DC	1A	125 V.AC	6	630 V.DC	2A	250 V.AC				<table border="1"> <tr> <td>J</td> <td>±5 %</td> </tr> <tr> <td>K</td> <td>±10 %</td> </tr> </table>	J	±5 %	K	±10 %	<table border="1"> <thead> <tr> <th>Code</th> <th>Lead Form</th> </tr> </thead> <tbody> <tr> <td>Blank</td> <td>Straight</td> </tr> <tr> <td>B</td> <td>Crimped lead</td> </tr> <tr> <td>Z</td> <td>Cut lead</td> </tr> <tr> <td>3</td> <td>Crimped taping (Ammo)</td> </tr> <tr> <td>6</td> <td>Crimped taping (Ammo)</td> </tr> </tbody> </table>		Code	Lead Form	Blank	Straight	B	Crimped lead	Z	Cut lead	3	Crimped taping (Ammo)	6	Crimped taping (Ammo)
1	100 V.DC	10	1000 V.DC																																								
2	250 V.DC	12	1250 V.DC																																								
4	400 V.DC	1A	125 V.AC																																								
6	630 V.DC	2A	250 V.AC																																								
J	±5 %																																										
K	±10 %																																										
Code	Lead Form																																										
Blank	Straight																																										
B	Crimped lead																																										
Z	Cut lead																																										
3	Crimped taping (Ammo)																																										
6	Crimped taping (Ammo)																																										

● Odd size taping

1	2	3	4	5	6	7	8	9	10	11	12
E	C	Q	E						R		F
Product code		Dielectric & construction		Rated voltage		Capacitance			Suffix	Cap. Tol.	Suffix

Specifications

Category temp. range (Including temperature-rise on unit surface)	100 V.DC, 250 V.DC, 400 V.DC, 630 V.DC, 1000 V.DC, 1250 V.DC	- 40 °C to +105 °C
	125 V.AC, 250 V.AC	- 40 °C to +105 °C
Rated voltage	100 V.DC, 250 V.DC, 400 V.DC, 630 V.DC, 1000 V.DC, 1250 V.DC (Derating of rated voltage by 1.25 %/°C at more than 85 °C) 125 V.AC, 250 V.AC	
Capacitance range	100 V.DC	0.56 μF to 10.0 μF (E12)
	250 V.DC	0.010 μF to 10.0 μF (E12)
	400 V.DC	0.010 μF to 2.2 μF (E12)
	630 V.DC	0.0010 μF to 2.2 μF (E12)
	1000 V.DC	0.010 μF to 0.22 μF (E12)
	1250 V.DC	0.0010 μF to 0.22 μF (E12)
	125 V.AC	0.010 μF to 0.068 μF (E12)
	250 V.AC	0.010 μF to 2.2 μF (E12)
Capacitance tolerance	±5 % (J), ±10 % (K)	
Dissipation factor (tan δ)	tan δ ≤ 1.0 % (20 °C, 1 kHz)	
Withstand voltage	• Rated volt. : 100 V.DC to 630 V.DC Between terminals : Rated volt. (V.DC) × 150 %, 60 s	
	• Rated volt. : 1000 V.DC, 1250 V.DC Between terminals : Rated volt. (V.DC) × 175 %, 2 s to 5 s or 1000 V.AC, 60 s Between terminals to enclosure : 1500 V.AC, 60 s	
	• Rated volt. : 125 V.AC, 250 V.AC Between terminals : Rated volt. (V.AC) × 230 %, 60 s Between terminals to enclosure : 1500 V.AC, 60 s	
Insulation resistance (IR)	100 V.DC to 630 V.DC : C ≤ 0.33 μF : IR ≥ 9000 MΩ C > 0.33 μF : IR ≥ 3000 MΩ · μF (20 °C, 100 V.DC, 60 s)	
	1000 V.DC, 1250 V.DC : IR ≥ 10000 MΩ (20 °C, 100 V.DC, 60 s) IR ≥ 2000 MΩ (20 °C, 500 V.DC, 60 s)	
	125 V.AC, 250 V.AC : C ≤ 0.47 μF : IR ≥ 2000 MΩ (20 °C, 500 V.DC, 60 s) C > 0.47 μF : IR ≥ 3000 MΩ · μF (20 °C, 100 V.DC, 60 s)	

- * In case of applying voltage in alternating current (50 Hz or 60 Hz sine wave) to a capacitor with DC rated voltage, please refer to the page of "Permissible voltage (R.M.S) in alternating current corresponding to DC rated voltage".
- * Voltage to be applied to ECQE1A (F) & ECQE2A (F) is only sine wave (50 Hz or 60 Hz).

Dimensions

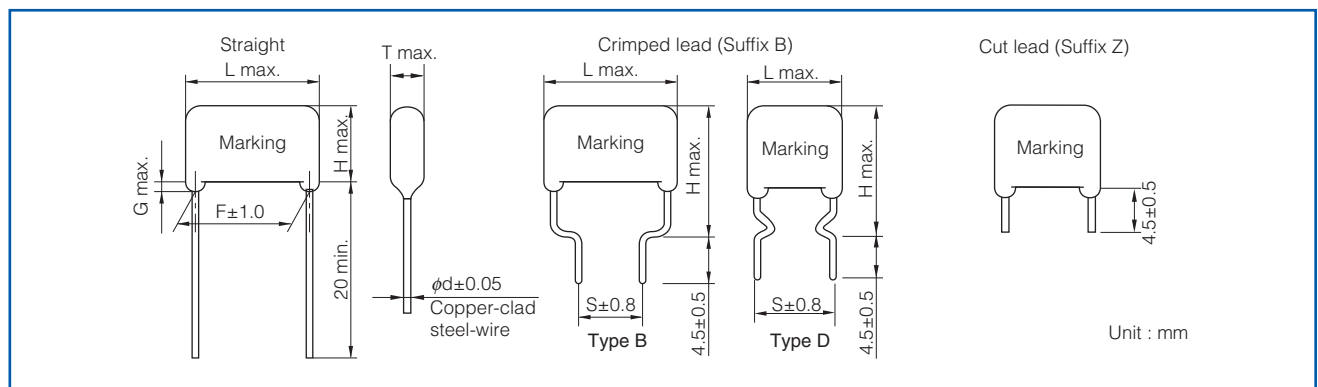

Packaging specifications for bulk package

- Packing quantity : 100 pcs./bag

Taping specifications for automatic insertion

● Taping style

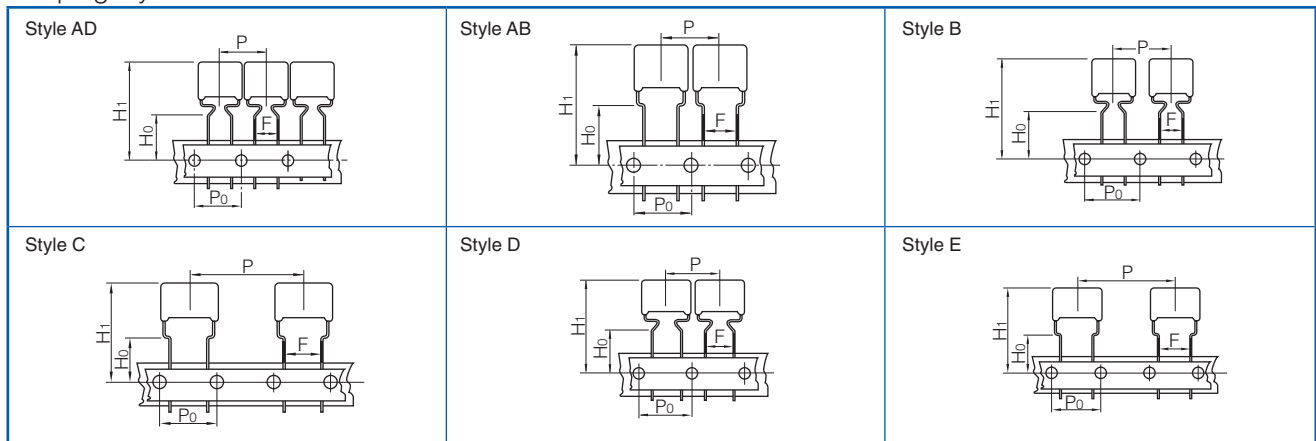

* Refer to the page of taping specifications.

● Packaging specifications

Series	Rated voltage	Capacitance range (μF)	Taping style							Packing	suffix
			AD	AS	AB	B	C	D	E		
ECQE(F)	100 V.DC	0.56 to 0.68	○							Ammo	() F3
		0.82 to 1.0				○				Ammo	() F3
		1.2 to 3.3					○			Ammo	() F3
		1.2 to 3.3							○	Ammo	R() F
	250 V.DC	0.010 to 0.27	○							Ammo	() F3
		0.33				○				Ammo	() F3
		0.39 to 1.5					○			Ammo	() F3
		0.010 to 0.33							○	Ammo	R() F
	400 V.DC	0.39 to 1.5							○	Ammo	R() F
		0.010 to 0.10	○							Ammo	() F3
		0.12 to 0.47					○			Ammo	() F3
		0.010 to 0.10							○	Ammo	R() F
	630 V.DC	0.12 to 0.47							○	Ammo	R() F
		0.0010 to 0.033	○							Ammo	() F3
		0.039 to 0.047				○				Ammo	() F3
		0.056 to 0.22					○			Ammo	() F3
	1000 V.DC	0.001 to 0.047							○	Ammo	R() F
		0.056 to 0.22							○	Ammo	R() F
		0.010 to 0.10							○	Ammo	R() F
		0.010 to 0.022							○	Ammo	R() F
125 V.AC	0.010 to 0.068			○					Ammo	() F6	
	0.010 to 0.068							○	Ammo	R() F	
250 V.AC	0.010 to 0.033			○					Ammo	() F6	
	0.010 to 0.047							○	Ammo	R() F	
	0.056 to 0.22							○	Ammo	R() F	

● Lead spacing

Style	Lead spacing
AD	5.0 mm
AB	5.0 mm
B	5.0 mm
C	5.0 mm
D	7.5 mm
E	7.5 mm

* See the column "Rating · Dimensions · Quantity" for packing quantity

Rating · Dimensions · Quantity

- Rated voltage : 100 V.DC, Capacitance tolerance : ± 5 % (J), ±10 % (K)

Part No.	Cap. (μF)	Dimensions (mm)								Min. order Q'ty			
		L max.	T max.	H max.		F	S	G max.	φd	Taping			Bulk
				Straight	Crimped lead					Standard 5 mm	Odd size 5 mm	Odd size 7.5 mm	
ECQE1564□F ()	0.56	12.0	5.5	10.9	15.9	10.0	10.0	1.0	0.6	500	-	-	500
ECQE1684□F ()	0.68	12.0	6.0	11.9	16.9	10.0	10.0	1.0	0.6				
ECQE1824□F ()	0.82	12.0	6.0	13.5	18.5	10.0	10.0	1.0	0.6				
ECQE1105□F ()	1.0	12.0	6.7	14.0	19.0	10.0	10.0	1.0	0.6				
ECQE1125□F ()	1.2	18.5	5.5	12.8	17.8	15.0	10.0	1.0	0.6				
ECQE1155□F ()	1.5	18.5	6.0	13.4	18.4	15.0	10.0	1.0	0.8				
ECQE1185□F ()	1.8	18.5	6.5	14.4	19.4	15.0	10.0	1.0	0.8				
ECQE1225□F ()	2.2	18.5	7.0	15.0	20.0	15.0	10.0	1.0	0.8				
ECQE1275□F ()	2.7	18.5	8.0	15.8	20.8	15.0	10.0	1.0	0.8				
ECQE1335□F ()	3.3	18.5	8.5	16.5	21.5	15.0	10.0	1.0	0.8				
ECQE1395□F ()	3.9	26.0	7.0	16.4	21.4	22.5	15.0	1.0	0.8				
ECQE1475□F ()	4.7	26.0	7.5	17.0	22.0	22.5	15.0	1.0	0.8				
ECQE1565□F ()	5.6	26.0	8.3	17.5	22.5	22.5	15.0	1.0	0.8				
ECQE1685□F ()	6.8	26.0	9.0	18.5	23.5	22.5	15.0	1.0	0.8				
ECQE1825□F ()	8.2	26.0	10.0	20.0	25.0	22.5	15.0	1.5	0.8				
ECQE1106□F ()	10.0	26.0	11.5	21.0	26.0	22.5	15.0	1.5	0.8				

* □ : Capacitance tolerance code
() : Suffix for lead crimped or taped type

Type D : 0.56 μF to 1.0 μF
Type B : 1.2 μF to 10.0 μF

Rating · Dimensions · Quantity

- Rated voltage : 250 V.DC, Capacitance tolerance : ± 5 % (J), ±10 % (K)

Part No.	Cap. (μF)	Dimensions (mm)								Min. order Q'ty			
		L max.	T max.	H max.		F	S	G max.	φd	Taping			Bulk
				Straight	Crimped lead					Standard 5 mm	Odd size 5 mm	Odd size 7.5 mm	
ECQE2103□F ()	0.010	10.3	4.3	7.4	12.4	7.5	7.5	1.0	0.6	1000	-	1000	500
ECQE2123□F ()	0.012	10.3	4.4	7.5	12.5	7.5	7.5	1.0	0.6				
ECQE2153□F ()	0.015	10.3	4.4	7.5	12.5	7.5	7.5	1.0	0.6				
ECQE2183□F ()	0.018	10.3	4.4	7.5	12.5	7.5	7.5	1.0	0.6				
ECQE2223□F ()	0.022	10.3	4.4	7.5	12.5	7.5	7.5	1.0	0.6				
ECQE2273□F ()	0.027	10.3	4.4	7.5	12.5	7.5	7.5	1.0	0.6				
ECQE2333□F ()	0.033	10.3	4.5	7.5	12.5	7.5	7.5	1.0	0.6				
ECQE2393□F ()	0.039	10.3	4.5	7.5	12.5	7.5	7.5	1.0	0.6				
ECQE2473□F ()	0.047	10.3	4.5	7.5	12.5	7.5	7.5	1.0	0.6				
ECQE2563□F ()	0.056	10.3	4.8	7.9	12.9	7.5	7.5	1.0	0.6				
ECQE2683□F ()	0.068	10.3	4.5	7.5	12.5	7.5	7.5	1.0	0.6				
ECQE2823□F ()	0.082	10.3	4.9	8.0	13.0	7.5	7.5	1.0	0.6				
ECQE2104□F ()	0.10	10.3	5.8	8.4	13.4	7.5	7.5	1.0	0.6				
ECQE2124□F ()	0.12	10.3	6.0	9.0	14.0	7.5	7.5	1.0	0.6				
ECQE2154□F ()	0.15	10.3	6.0	10.8	15.8	7.5	7.5	1.0	0.6				
ECQE2184□F ()	0.18	12.0	5.0	10.3	15.3	10.0	10.0	1.0	0.6				
ECQE2224□F ()	0.22	12.0	5.5	10.5	15.5	10.0	10.0	1.0	0.6				
ECQE2274□F ()	0.27	12.0	6.0	11.5	16.5	10.0	10.0	1.0	0.6				
ECQE2334□F ()	0.33	12.0	6.5	12.0	17.0	10.0	10.0	1.0	0.6				
ECQE2394□F ()	0.39	18.5	4.9	12.0	17.0	15.0	10.0	1.0	0.6				
ECQE2474□F ()	0.47	18.5	5.3	12.5	17.5	15.0	10.0	1.0	0.6				
ECQE2564□F ()	0.56	18.5	5.5	13.0	18.0	15.0	10.0	1.0	0.6				
ECQE2684□F ()	0.68	18.5	6.0	13.5	18.5	15.0	10.0	1.0	0.8				
ECQE2824□F ()	0.82	18.5	6.5	14.5	19.5	15.0	10.0	1.0	0.8				
ECQE2105□F ()	1.0	18.5	7.4	15.0	20.0	15.0	10.0	1.0	0.8				
ECQE2125□F ()	1.2	18.5	8.0	15.9	20.9	15.0	10.0	1.0	0.8				
ECQE2155□F ()	1.5	18.5	9.0	16.8	21.8	15.0	10.0	1.0	0.8				
ECQE2185□F ()	1.8	26.0	7.5	15.5	20.5	22.5	15.0	1.0	0.8				
ECQE2225□F ()	2.2	26.0	8.5	16.3	21.3	22.5	15.0	1.0	0.8				
ECQE2275□F ()	2.7	26.0	9.4	17.0	22.0	22.5	15.0	1.0	0.8				
ECQE2335□F ()	3.3	26.0	10.3	18.0	23.0	22.5	15.0	1.5	0.8				
ECQE2395□F ()	3.9	26.0	11.0	20.5	25.5	22.5	15.0	1.5	0.8				
ECQE2475□F ()	4.7	26.0	12.0	21.5	26.5	22.5	15.0	1.5	0.8				
ECQE2565□F ()	5.6	31.0	11.8	21.0	26.0	27.5	22.5	1.5	0.8				
ECQE2685□F ()	6.8	31.0	13.0	22.4	27.4	27.5	22.5	1.5	0.8				
ECQE2825□F ()	8.2	31.0	14.3	23.5	28.5	27.5	22.5	1.5	0.8				
ECQE2106□F ()	10.0	31.0	15.9	25.8	30.8	27.5	22.5	1.5	0.8				

* □ : Capacitance tolerance code
() : Suffix for lead crimped or taped type

Type D : 0.010 μF to 0.33 μF
Type B : 0.39 μF to 10.0 μF

Rating · Dimensions · Quantity

● Rated voltage : 400 V.DC, Capacitance tolerance : ± 5 % (J), ± 10 % (K)

Part No.	Cap. (μ F)	Dimensions (mm)								Min. order Q'ty					
		L max.	T max.	H max.		F		S		G max.	ϕ d	Taping			Bulk Straight - Crimped lead
				Straight	Crimped lead	Straight	Crimped lead	Straight	Crimped lead			Standard 5 mm	Odd size 5 mm	Odd size 7.5 mm	
ECQE4103□F()	0.010	10.3	4.3	7.4	12.4	7.5	7.5	1.0	0.6	1000	-	-	1000	500	
ECQE4123□F()	0.012	10.3	4.4	7.5	12.5	7.5	7.5	1.0	0.6						
ECQE4153□F()	0.015	10.3	4.4	7.5	12.5	7.5	7.5	1.0	0.6						
ECQE4183□F()	0.018	10.3	4.4	7.5	12.5	7.5	7.5	1.0	0.6						
ECQE4223□F()	0.022	10.3	4.8	7.9	12.9	7.5	7.5	1.0	0.6						
ECQE4273□F()	0.027	10.3	5.5	8.0	13.0	7.5	7.5	1.0	0.6						
ECQE4333□F()	0.033	10.3	6.0	9.0	14.0	7.5	7.5	1.0	0.6	500	-	-	-		
ECQE4393□F()	0.039	12.0	4.9	8.0	13.0	10.0	10.0	1.0	0.6						
ECQE4473□F()	0.047	12.0	5.0	8.3	13.3	10.0	10.0	1.0	0.6						
ECQE4563□F()	0.056	12.0	5.0	10.0	15.0	10.0	10.0	1.0	0.6						
ECQE4683□F()	0.068	12.0	5.4	10.5	15.5	10.0	10.0	1.0	0.6						
ECQE4823□F()	0.082	12.0	5.8	11.0	16.0	10.0	10.0	1.0	0.6						
ECQE4104□F()	0.10	12.0	6.3	12.0	17.0	10.0	10.0	1.0	0.6	-	-	-	-		
ECQE4124□F()	0.12	18.5	5.0	10.0	15.0	15.0	10.0	1.0	0.6						
ECQE4154□F()	0.15	18.5	5.0	12.4	17.4	15.0	10.0	1.0	0.6						
ECQE4184□F()	0.18	18.5	5.4	12.5	17.5	15.0	10.0	1.0	0.6						
ECQE4224□F()	0.22	18.5	5.9	13.0	18.0	15.0	10.0	1.0	0.6						
ECQE4274□F()	0.27	18.5	6.5	14.3	19.3	15.0	10.0	1.0	0.8						
ECQE4334□F()	0.33	18.5	7.0	14.9	19.9	15.0	10.0	1.0	0.8						
ECQE4394□F()	0.39	18.5	7.5	15.4	20.4	15.0	10.0	1.0	0.8						
ECQE4474□F()	0.47	18.5	7.8	17.0	22.0	15.0	10.0	1.0	0.8						
ECQE4564□F()	0.56	26.0	6.5	16.0	21.0	22.5	15.0	1.0	0.8						
ECQE4684□F()	0.68	26.0	7.0	16.5	21.5	22.5	15.0	1.0	0.8						
ECQE4824□F()	0.82	26.0	7.9	17.3	22.3	22.5	15.0	1.0	0.8						
ECQE4105□F()	1.0	26.0	8.5	18.0	23.0	22.5	15.0	1.0	0.8						
ECQE4125□F()	1.2	26.0	9.5	18.9	23.9	22.5	15.0	1.0	0.8						
ECQE4155□F()	1.5	31.0	9.5	19.0	24.0	27.5	22.5	1.0	0.8						
ECQE4185□F()	1.8	31.0	11.0	20.5	25.5	27.5	22.5	1.5	0.8						
ECQE4225□F()	2.2	31.0	11.0	22.0	27.0	27.5	22.5	1.5	0.8						

* □ : Capacitance tolerance code
() : Suffix for lead crimped or taped type

Type D : 0.010 μ F to 0.10 μ F
Type B : 0.12 μ F to 2.2 μ F

Rating · Dimensions · Quantity

● Rated voltage : 630 V.DC, Capacitance tolerance : ± 5 % (J), ±10 % (K)

Part No.	Cap. (μ F)	Dimensions (mm)								Min. order Q'ty				
		L max.	T max.	H max.		F	S	G max.	ϕ d	Taping			Bulk	
				Straight	Crimped lead					Straight	Crimped lead	Straight	Standard 5 mm	Odd size 5 mm
ECQE6102□F()	0.0010	10.0	4.5	9.5	14.5	7.5	5.0	1.0	0.6	1000	-	1000	500	500
ECQE6122□F()	0.0012	10.0	4.5	10.0	15.0	7.5	5.0	1.0	0.6					
ECQE6152□F()	0.0015	10.0	4.5	10.0	15.0	7.5	5.0	1.0	0.6					
ECQE6182□F()	0.0018	10.0	4.5	10.0	15.0	7.5	5.0	1.0	0.6					
ECQE6222□F()	0.0022	10.0	4.5	10.0	15.0	7.5	5.0	1.0	0.6					
ECQE6272□F()	0.0027	10.0	4.5	10.0	15.0	7.5	5.0	1.0	0.6					
ECQE6332□F()	0.0033	10.0	4.5	10.0	15.0	7.5	5.0	1.0	0.6					
ECQE6392□F()	0.0039	10.0	4.5	10.0	15.0	7.5	5.0	1.0	0.6					
ECQE6472□F()	0.0047	12.0	4.5	10.0	15.0	10.0	7.5	1.0	0.6					
ECQE6562□F()	0.0056	12.0	4.5	10.0	15.0	10.0	7.5	1.0	0.6					
ECQE6682□F()	0.0068	12.0	4.9	10.0	15.0	10.0	7.5	1.0	0.6					
ECQE6822□F()	0.0082	12.0	4.5	10.0	15.0	10.0	7.5	1.0	0.6					
ECQE6103□F()	0.010	12.0	4.5	7.5	12.5	10.0	10.0	1.0	0.6					
ECQE6123□F()	0.012	12.0	4.5	7.8	12.8	10.0	10.0	1.0	0.6					
ECQE6153□F()	0.015	12.0	5.0	8.2	13.2	10.0	10.0	1.0	0.6					
ECQE6183□F()	0.018	12.0	4.9	10.0	15.0	10.0	10.0	1.0	0.6					
ECQE6223□F()	0.022	12.0	5.3	10.5	15.5	10.0	10.0	1.0	0.6					
ECQE6273□F()	0.027	12.0	5.5	10.9	15.9	10.0	10.0	1.0	0.6					
ECQE6333□F()	0.033	12.0	6.0	11.9	16.9	10.0	10.0	1.0	0.6					
ECQE6393□F()	0.039	12.0	6.0	13.4	18.4	10.0	10.0	1.0	0.6					
ECQE6473□F()	0.047	12.0	6.5	13.5	18.5	10.0	10.0	1.0	0.6					
ECQE6563□F()	0.056	18.5	5.4	10.5	15.5	15.0	10.0	1.0	0.6					
ECQE6683□F()	0.068	18.5	5.8	11.0	16.0	15.0	10.0	1.0	0.6					
ECQE6823□F()	0.082	18.5	6.5	12.0	17.0	15.0	10.0	1.0	0.6					
ECQE6104□F()	0.10	18.5	6.3	14.0	19.0	15.0	10.0	1.0	0.6					
ECQE6124□F()	0.12	18.5	6.3	14.5	19.5	15.0	10.0	1.0	0.8					
ECQE6154□F()	0.15	18.5	7.5	15.4	20.4	15.0	10.0	1.0	0.8					
ECQE6184□F()	0.18	18.5	8.0	16.0	21.0	15.0	10.0	1.0	0.8					
ECQE6224□F()	0.22	18.5	9.0	16.5	21.5	15.0	10.0	1.0	0.8					
ECQE6274□F()	0.27	26.0	7.0	16.5	21.5	22.5	15.0	1.0	0.8					
ECQE6334□F()	0.33	26.0	7.8	17.0	22.0	22.5	15.0	1.0	0.8					
ECQE6394□F()	0.39	26.0	8.5	17.9	22.9	22.5	15.0	1.0	0.8					
ECQE6474□F()	0.47	26.0	9.3	18.5	23.5	22.5	15.0	1.0	0.8					
ECQE6564□F()	0.56	26.0	10.0	20.0	25.0	22.5	15.0	1.5	0.8					
ECQE6684□F()	0.68	26.0	11.5	21.0	26.0	22.5	15.0	1.5	0.8					
ECQE6824□F()	0.82	31.0	11.3	20.5	25.5	27.5	22.5	1.5	0.8					
ECQE6105□F()	1.0	31.0	12.5	21.9	26.9	27.5	22.5	1.5	0.8					
ECQE6125□F()	1.2	31.0	13.5	23.0	28.0	27.5	22.5	1.5	0.8					
ECQE6155□F()	1.5	31.0	15.3	24.7	29.7	27.5	22.5	1.5	0.8					
ECQE6185□F()	1.8	31.0	16.8	27.0	32.0	27.5	22.5	1.5	0.8					
ECQE6225□F()	2.2	31.0	19.5	29.0	34.0	27.5	22.5	1.5	0.8					

* □ : Capacitance tolerance code
() : Suffix for lead crimped or taped type

Type D : 0.010 μ F to 0.047 μ F
Type B : 0.0010 μ F to 0.0082 μ F
0.056 μ F to 2.2 μ F

Rating · Dimensions · Quantity

● Rated voltage : 1000 V.DC, (Note) 125 V.AC, Capacitance tolerance : ±5 % (J), ±10 % (K)

Part No.	Cap. (μ F)	Dimensions (mm)								Min. order Q'ty	
		L max.	T max.	H max.		F	S	G max.	ϕ d	Taping	Bulk
				Straight	Crimped lead					Straight	Crimped lead
ECQE10103□F()	0.010	15.5	6.0	11.0	16.0	12.5	12.5	1.0	0.6	500	500
ECQE10123□F()	0.012	15.5	6.0	12.0	17.0	12.5	12.5	1.0	0.6		
ECQE10153□F()	0.015	15.5	7.0	12.5	17.5	12.5	12.5	1.0	0.6		
ECQE10183□F()	0.018	15.5	7.5	13.0	20.0	12.5	12.5	1.0	0.8	400	
ECQE10223□F()	0.022	15.5	7.5	15.5	22.5	12.5	12.5	1.0	0.8	500	
ECQE10273□F()	0.027	21.0	6.0	13.0	18.0	17.5	12.5	1.0	0.8		
ECQE10333□F()	0.033	21.0	6.5	14.0	19.0	17.5	12.5	1.0	0.8	500	
ECQE10393□F()	0.039	21.0	7.0	14.5	19.5	17.5	12.5	1.0	0.8		
ECQE10473□F()	0.047	21.0	7.5	15.5	20.5	17.5	12.5	1.0	0.8	400	
ECQE10563□F()	0.056	21.0	7.5	17.0	22.0	17.5	12.5	1.0	0.8		
ECQE10683□F()	0.068	21.0	8.5	18.0	23.0	17.5	12.5	1.0	0.8	300	
ECQE10823□F()	0.082	21.0	9.0	18.5	23.5	17.5	12.5	1.0	0.8		
ECQE10104□F()	0.10	21.0	10.0	20.0	25.0	17.5	12.5	1.0	0.8	-	
ECQE10124□F()	0.12	26.0	9.0	18.5	23.5	22.5	17.5	1.0	0.8		
ECQE10154□F()	0.15	26.0	10.0	20.0	25.0	22.5	17.5	1.5	0.8		
ECQE10184□F()	0.18	26.0	10.5	22.0	27.0	22.5	17.5	1.5	0.8		
ECQE10224□F()	0.22	26.0	12.0	23.0	28.0	22.5	17.5	1.5	0.8		

* □ : Capacitance tolerance code
() : Suffix for lead crimped or taped type

Type D : 0.010 μ F to 0.022 μ F
Type B : 0.027 μ F to 0.22 μ F

Note) This type has two rated voltage, one is DC rated voltage another is AC rated voltage.
DC rated voltage is 1000 V.DC, AC rated voltage is 125 V.AC.
Making for rated voltage is "1000 V, 125 V \sim "

When capacitors use in secondary side of power source, and in case of applying voltage in altering current (50 Hz or 60 Hz sine wave) to a capacitor, please refer to the page of "Permissible voltage (R.M.S) in altering current corresponding to DC rated voltage".

When capacitors use in primary side of power source, the rated voltage is shown 125 V.AC. Voltage to be applied to capacitors in only sine wave (50 Hz or 60 Hz).

AC rated capacitors complying with clause 1 of "Electrical Appliance and Material Safety Law". And not complying with clause 2 of "Electrical Appliance and Material Safety Law", in this case please use ECQUA type or ECQUL type.

Rating · Dimensions · Quantity

● Rated voltage : 1250 V.DC, (Note) 125 V.AC, Capacitance tolerance : ±5 % (J), ±10 % (K)

Part No.	Cap. (μ F)	Dimensions (mm)								Min. order Q'ty				
		L max.	T max.	H max.		F		S		G max.	ϕ d	Taping	Bulk	
				Straight	Crimped lead	Straight	Crimped lead	Straight	Crimped lead			7.5 mm	Straight	Crimped lead
ECQE12102□F()	0.0010	15.5	6.0	11.0	16.0	12.5	10.0	1.0	0.6	500	500	500		
ECQE12122□F()	0.0012	15.5	6.0	11.0	16.0	12.5	10.0	1.0	0.6					
ECQE12152□F()	0.0015	15.5	6.0	11.0	16.0	12.5	10.0	1.0	0.6					
ECQE12182□F()	0.0018	15.5	6.0	11.0	16.0	12.5	10.0	1.0	0.6					
ECQE12222□F()	0.0022	15.5	6.0	11.5	16.5	12.5	10.0	1.0	0.6					
ECQE12272□F()	0.0027	15.5	6.5	12.0	17.0	12.5	10.0	1.0	0.6					
ECQE12332□F()	0.0033	15.5	6.0	11.5	16.5	12.5	10.0	1.0	0.6					
ECQE12392□F()	0.0039	15.5	6.5	12.0	17.0	12.5	10.0	1.0	0.6					
ECQE12472□F()	0.0047	15.5	7.0	12.5	17.5	12.5	10.0	1.0	0.6					
ECQE12562□F()	0.0056	15.5	7.5	13.0	18.0	12.5	10.0	1.0	0.6					
ECQE12682□F()	0.0068	15.5	7.5	15.0	20.0	12.5	10.0	1.0	0.6	400	500	500		
ECQE12822□F()	0.0082	21.0	5.0	12.0	17.0	17.5	12.5	1.0	0.6					
ECQE12103□F()	0.010	21.0	5.0	12.5	17.5	17.5	12.5	1.0	0.6	500	500	500		
ECQE12123□F()	0.012	21.0	5.5	13.0	18.0	17.5	12.5	1.0	0.6					
ECQE12153□F()	0.015	21.0	6.0	13.5	18.5	17.5	12.5	1.0	0.6					
ECQE12183□F()	0.018	21.0	6.5	14.5	19.5	17.5	12.5	1.0	0.8					
ECQE12223□F()	0.022	21.0	7.0	15.0	20.0	17.5	12.5	1.0	0.8					
ECQE12273□F()	0.027	26.0	6.0	15.5	20.5	22.5	17.5	1.0	0.8					
ECQE12333□F()	0.033	26.0	6.5	16.0	21.0	22.5	17.5	1.0	0.8	-	400	500		
ECQE12393□F()	0.039	26.0	7.0	16.5	21.5	22.5	17.5	1.0	0.8					
ECQE12473□F()	0.047	26.0	8.0	17.0	22.0	22.5	17.5	1.0	0.8					
ECQE12563□F()	0.056	31.0	7.5	17.0	22.0	27.5	22.5	1.0	0.8					
ECQE12683□F()	0.068	31.0	8.0	17.5	22.5	27.5	22.5	1.0	0.8					
ECQE12823□F()	0.082	31.0	9.0	18.5	23.5	27.5	22.5	1.0	0.8					
ECQE12104□F()	0.10	31.0	10.0	19.5	24.5	27.5	22.5	1.0	0.8					
ECQE12124□F()	0.12	31.0	11.5	20.5	25.5	27.5	22.5	1.5	0.8					
ECQE12154□F()	0.15	31.0	12.0	23.0	28.0	27.5	22.5	1.5	0.8					
ECQE12184□F()	0.18	31.0	13.0	24.5	29.5	27.5	22.5	1.5	0.8					
ECQE12224□F()	0.22	31.0	14.5	26.5	31.5	27.5	22.5	1.5	0.8					

* □ : Capacitance tolerance code
() : Suffix for lead crimped or taped type

Type D : 0.0010 μ F to 0.0068 μ F
Type B : 0.0082 μ F to 0.22 μ F

Note) This type has two rated voltage, one is DC rated voltage another is AC rated voltage.
DC rated voltage is 1250 V.DC, AC rated voltage is 125 V.AC.
Making for rated voltage is "1250 V, 125 V \sim "

When capacitors use in secondary side of power source, and in case of applying voltage in altering current (50 Hz or 60 Hz sine wave) to a capacitor, please refer to the page of "Permissible voltage (R.M.S) in altering current corresponding to DC rated voltage".

When capacitors use in primary side of power source, the rated voltage is shown 125 V.AC. Voltage to be applied to capacitors in only sine wave (50 Hz or 60 Hz).

AC rated capacitors complying with clause 1 of "Electrical Appliance and Material Safety Law". And not complying with clause 2 of "Electrical Appliance and Material Safety Law", in this case please use ECQUA type or ECQUL type.

Rating · Dimensions · Quantity

- Rated voltage : 125 V.AC, Capacitance tolerance : $\pm 5\%$ (J), $\pm 10\%$ (K)
Noise suppression Capacitors (Across-the-line)

Part No.	Cap. (μ F)	Dimensions (mm)								Min. order Q'ty					
		L max.	T max.	H max.		F		S		G max.	ϕ d	Taping			Bulk
				Straight	Crimped lead	Straight	Crimped lead	Straight	Straight			Standard 5 mm	Odd size 5 mm	Odd size 7.5 mm	
ECQE1A103□F()	0.010	10.5	4.5	7.5	12.5	7.5	7.5	7.5	1.0	0.6	1000	-	1000	500	
ECQE1A123□F()	0.012	10.5	4.4	7.5	12.5	7.5	7.5	1.0	0.6						
ECQE1A153□F()	0.015	10.5	4.4	7.5	12.5	7.5	7.5	1.0	0.6						
ECQE1A183□F()	0.018	10.5	4.4	7.5	12.5	7.5	7.5	1.0	0.6						
ECQE1A223□F()	0.022	10.5	4.4	7.5	12.5	7.5	7.5	1.0	0.6						
ECQE1A273□F()	0.027	10.5	4.4	7.5	12.5	7.5	7.5	1.0	0.6						
ECQE1A333□F()	0.033	10.5	4.5	7.8	12.8	7.5	7.5	1.0	0.6						
ECQE1A393□F()	0.039	10.5	4.5	7.8	12.8	7.5	7.5	1.0	0.6						
ECQE1A473□F()	0.047	10.5	5.5	8.0	13.0	7.5	7.5	1.0	0.6	500					
ECQE1A563□F()	0.056	10.5	5.9	8.5	13.5	7.5	7.5	1.0	0.6						
ECQE1A683□F()	0.068	10.5	6.3	9.4	14.4	7.5	7.5	1.0	0.6						

* □ : Capacitance tolerance code
() : Suffix for lead crimped or taped type

Type D : 0.010 μ F to 0.068 μ F

Notice for AC rated

AC rated capacitors complying with clause 1 of "Electrical Appliance and Material Safety Law".
As for clause 2 of "Electrical Appliance and Material Safety Law", please use ECQUA type or ECQUL type.

When using these capacitors as a across-the-line capacitor, it shall be required to follow either item 1. or item 2. condition.

1. Capacitor shall be connected in parallel with varistor (Specified varistor voltage in table 1.)
2. Voltage applied for capacitor shall not exceed other than specified in table 1, when using these capacitors

Table 1

Capacitor rated voltage	Varistor voltage	Pulse voltage
125 V.AC	250 V	250 V _{0-P}

Rating · Dimensions · Quantity

- Rated voltage : 250 V.AC, Capacitance tolerance : ±5 %(J), ±10 %(K)
Noise suppression Capacitors (Across-the-line)

Part No.	Cap. (μF)	Dimensions (mm)								Min. order Q'ty			
		L max.	T max.	H max.		F		S	G max.	Taping		Bulk	
				Straight	Crimped lead	Straight	Crimped lead	Straight	φd	Standard 5 mm	Odd size 7.5 mm	Straight	Crimped lead
ECQE2A103□F()	0.010	12.5	5.5	10.8	15.8	10.0	10.0	1.0	0.6	500	1000		
ECQE2A123□F()	0.012	12.5	6.0	11.5	16.5	10.0	10.0	1.0	0.6				
ECQE2A153□F()	0.015	12.5	6.3	9.9	14.9	10.0	10.0	1.0	0.6				
ECQE2A183□F()	0.018	12.5	6.0	11.9	16.9	10.0	10.0	1.0	0.6				
ECQE2A223□F()	0.022	12.5	6.0	11.5	16.5	10.0	10.0	1.0	0.6				
ECQE2A273□F()	0.027	12.5	5.5	10.9	15.9	10.0	10.0	1.0	0.6				
ECQE2A333□F()	0.033	12.5	6.0	11.9	16.9	10.0	10.0	1.0	0.6				
ECQE2A393□F()	0.039	12.5	6.0	13.4	18.4	10.0	10.0	1.0	0.6				
ECQE2A473□F()	0.047	12.5	6.5	14.4	19.4	10.0	10.0	1.0	0.6				
ECQE2A563□F()	0.056	18.5	5.4	10.5	15.5	15.0	10.0	1.0	0.6				
ECQE2A683□F()	0.068	18.5	5.8	11.0	16.0	15.0	10.0	1.0	0.6				
ECQE2A823□F()	0.082	18.5	6.3	12.0	17.0	15.0	10.0	1.0	0.6				
ECQE2A104□F()	0.10	18.5	6.3	14.0	19.0	15.0	10.0	1.0	0.6				
ECQE2A124□F()	0.12	18.5	6.8	14.5	19.5	15.0	10.0	1.0	0.8				
ECQE2A154□F()	0.15	18.5	7.5	15.4	20.4	15.0	10.0	1.0	0.8				
ECQE2A184□F()	0.18	18.5	8.0	16.0	21.0	15.0	10.0	1.0	0.8				
ECQE2A224□F()	0.22	18.5	9.0	16.9	21.9	15.0	10.0	1.0	0.8				
ECQE2A274□F()	0.27	26.0	7.0	16.5	21.5	22.5	15.0	1.0	0.8				
ECQE2A334□F()	0.33	26.0	7.8	17.0	22.0	22.5	15.0	1.0	0.8				
ECQE2A394□F()	0.39	26.0	8.5	17.9	22.9	22.5	15.0	1.0	0.8				
ECQE2A474□F()	0.47	26.0	9.3	18.5	23.5	22.5	15.0	1.0	0.8				
ECQE2A564P()()	0.56	26.0	10.0	20.0	—	22.5	—	1.0	0.8				
ECQE2A684P()()	0.68	26.0	11.5	21.0	—	22.5	—	1.0	0.8				
ECQE2A824P()()	0.82	26.0	13.0	22.5	—	22.5	—	1.0	0.8				
ECQE2A105P()()	1.0	31.0	12.5	21.9	—	27.5	—	1.5	0.8				
ECQE2A125P()()	1.2	31.0	13.5	23.0	—	27.5	—	1.5	0.8				
ECQE2A155P()()	1.5	31.0	15.3	24.7	—	27.5	—	1.5	0.8				
ECQE2A185P()()	1.8	31.0	16.8	27.0	—	27.5	—	1.5	0.8				
ECQE2A225P()()	2.2	31.0	19.5	29.0	—	27.5	—	1.5	0.8				

* □ : Capacitance tolerance code
() : Suffix for lead crimped or taped type

Type D : 0.010 μF to 0.047 μF
Type B : 0.056 μF to 0.47 μF

* Please consult us about Crimped lead type of 0.56 μF to 2.2 μF.

Notice for AC rated

AC rated capacitors complying with clause 1 of "Electrical Appliance and Material Safety Law".
As for clause 2 of "Electrical Appliance and Material Safety Law", please use ECQUA type or ECQUL type.

When using these capacitors as a across-the-line capacitor, it shall be required to follow either item 1. or item 2. condition.

1. Capacitor shall be connected in parallel with varistor (Specified varistor voltage in table 1.)
2. Voltage applied for capacitor shall not exceed other than specified in table 1, when using these capacitors

Table 1

Capacitor rated voltage	Varistor voltage	Pulse voltage
250 V.AC	470 V	630 V _{0,P}

Metallized Polyester Film Capacitor

Series : **ECQE(B)**

Non-inductive construction using metallized polyester film with flame retardant epoxy resin coating



Features

- Self-healing property
- Small size
- Excellent electrical characteristics
- Flame retardant epoxy resin coating
- RoHS directive compliant

Recommended applications

- General purpose usage
 - * Please contact us when applications are CDI, ignitor etc.

Explanation of part number

1	2	3	4	5	6	7	8	9	10	11	12																						
E	C	Q	E							B																							
Product code		Dielectric & construction		Rated voltage		Capacitance			Cap. Tol.	Suffix	Suffix																						
				<table border="1"> <tr><td>2</td><td>250 V.DC</td></tr> <tr><td>1A</td><td>125 V.AC</td></tr> </table>		2	250 V.DC	1A	125 V.AC				<table border="1"> <tr><td>J</td><td>±5 %</td></tr> <tr><td>K</td><td>±10 %</td></tr> </table>	J	±5 %	K	±10 %	<table border="1"> <thead> <tr><th>Code</th><th>Lead Form</th></tr> </thead> <tbody> <tr><td>Blank</td><td>Straight</td></tr> <tr><td>B</td><td>Crimped lead</td></tr> <tr><td>Z</td><td>Cut lead</td></tr> <tr><td>2</td><td>Straight taping (Ammo)</td></tr> <tr><td>3</td><td>Crimped taping (Ammo)</td></tr> <tr><td>6</td><td>Crimped taping (Ammo)</td></tr> </tbody> </table>		Code	Lead Form	Blank	Straight	B	Crimped lead	Z	Cut lead	2	Straight taping (Ammo)	3	Crimped taping (Ammo)	6	Crimped taping (Ammo)
2	250 V.DC																																
1A	125 V.AC																																
J	±5 %																																
K	±10 %																																
Code	Lead Form																																
Blank	Straight																																
B	Crimped lead																																
Z	Cut lead																																
2	Straight taping (Ammo)																																
3	Crimped taping (Ammo)																																
6	Crimped taping (Ammo)																																

- Odd size taping

1	2	3	4	5	6	7	8	9	10	11	12
E	C	Q	E						R		B
Product code		Dielectric & construction		Rated voltage		Capacitance			Suffix	Cap. Tol.	Suffix

Specifications

Category temp. range (Including temperature-rise on unit surface)	250 V.DC	- 40 °C to +105 °C							
	125 V.AC	- 40 °C to +105 °C							
Rated voltage	250 V.DC, 125 V.AC (250 V.DC : Derating of rated voltage by 1.25 %/°C at more than 85 °C)								
Capacitance range	250 V.DC	0.010 μF to 4.7 μF (E12)							
	125 V.AC	0.010 μF to 4.7 μF (E12)							
Capacitance tolerance	±5 % (J), ±10 % (K)								
Dissipation factor (tan δ)	tan δ ≤ 1.0 % (20 °C, 1 kHz)								
Withstand voltage	<ul style="list-style-type: none"> • Rated volt. : 250 V.DC Between terminals : Rated volt. (V.DC) × 150 %, 60 s • Rated volt. : 125 V.AC Between terminals : Rated volt. (V.AC) × 230 %, 60 s Between terminals to enclosure : 1500 V.AC, 60 s 								
	Insulation resistance (IR)	<table border="1"> <tr> <td>250 V.DC</td> <td>C ≤ 0.33 μF : IR ≥ 9000 MΩ (20 °C, 100 V.DC, 60 s)</td> </tr> <tr> <td></td> <td>C > 0.33 μF : IR ≥ 3000 MΩ · μF (20 °C, 100 V.DC, 60 s)</td> </tr> <tr> <td>125 V.AC</td> <td>C ≤ 0.47 μF : IR ≥ 2000 MΩ (20 °C, 500 V.DC, 60 s)</td> </tr> <tr> <td></td> <td>C > 0.47 μF : IR ≥ 3000 MΩ · μF (20 °C, 100 V.DC, 60 s)</td> </tr> </table>	250 V.DC	C ≤ 0.33 μF : IR ≥ 9000 MΩ (20 °C, 100 V.DC, 60 s)		C > 0.33 μF : IR ≥ 3000 MΩ · μF (20 °C, 100 V.DC, 60 s)	125 V.AC	C ≤ 0.47 μF : IR ≥ 2000 MΩ (20 °C, 500 V.DC, 60 s)	
250 V.DC	C ≤ 0.33 μF : IR ≥ 9000 MΩ (20 °C, 100 V.DC, 60 s)								
	C > 0.33 μF : IR ≥ 3000 MΩ · μF (20 °C, 100 V.DC, 60 s)								
125 V.AC	C ≤ 0.47 μF : IR ≥ 2000 MΩ (20 °C, 500 V.DC, 60 s)								
	C > 0.47 μF : IR ≥ 3000 MΩ · μF (20 °C, 100 V.DC, 60 s)								

* In case of applying voltage in alternating current (50 Hz or 60 Hz sine wave) to a capacitor with DC rated voltage, please refer to the page of "Permissible voltage (R.M.S) in alternating current corresponding to DC rated voltage".

* Voltage to be applied to ECQE1A (B) is only sine wave (50 Hz or 60 Hz).

Dimensions

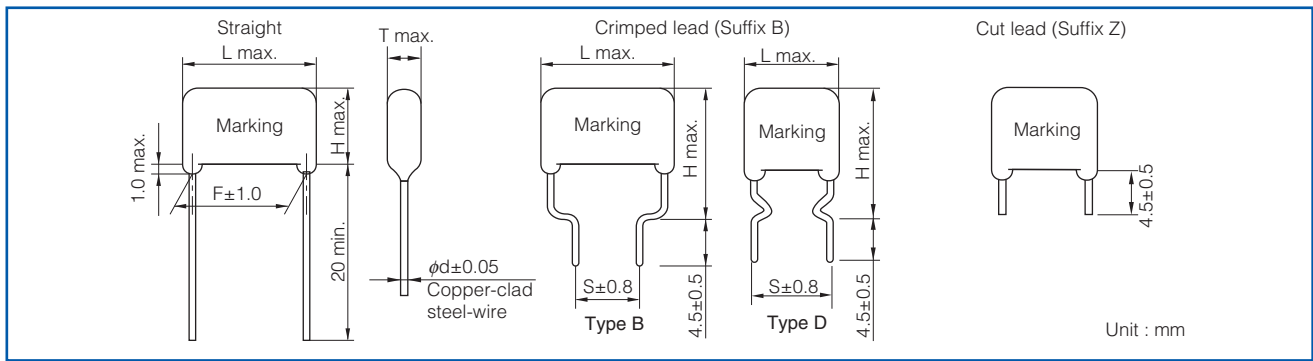

Packaging specifications for bulk package

- Packing quantity : 100 pcs./bag

Taping specifications for automatic insertion

- Taping style

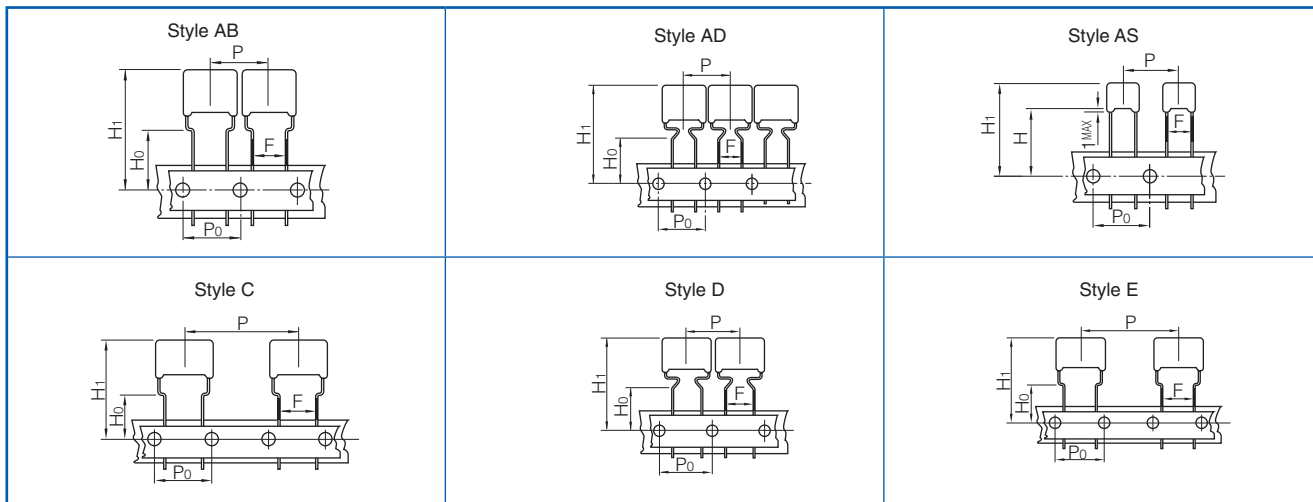

* Refer to the page of taping specifications.

- Packaging specifications

Series	Rated voltage	Capacitance range (μF)	Taping style							Packing	suffix
			AD	AS	AB	B	C	D	E		
ECQE(B)	250 V.DC	0.010 to 0.15		○						Ammo	() B2
		0.010 to 0.68	○							Ammo	() B3
		0.82 to 1.5					○			Ammo	() B3
		0.18 to 0.68						○		Ammo	R() B
		0.82 to 4.7							○	Ammo	R() B
	125 V.AC	0.010 to 0.068		○						Ammo	() B2
		0.082 to 0.22			○					Ammo	() B6
		0.27 to 2.7					○			Ammo	() B3
		0.082 to 0.68						○		Ammo	R() B
		0.82 to 2.7							○	Ammo	R() B

- Lead spacing

Style	Lead spacing
AD	5.0 mm
AS	5.0 mm
AB	5.0 mm
C	5.0 mm
D	7.5 mm
E	7.5 mm

* See the column "Rating · Dimensions · Quantity" for packing quantity

Rating · Dimensions · Quantity

● Rated voltage : 250 V.DC, Capacitance tolerance : ± 5 %(J), ±10 %(K)

Part No.	Cap. (μ F)	Dimensions (mm)							Min. order Q'ty												
		L max.	T max.	H max.		F	S	ϕ d	Taping			Bulk									
				Straight	Crimped lead	Straight	Crimped lead		Standard 5 mm	Odd size 5 mm	Odd size 7.5 mm	Straight - Crimped lead									
ECQE2103□B()	0.010	7.9	4.2	7.1	12.1	5.0	5.0	0.5	2000												
ECQE2123□B()	0.012	7.9	4.2	7.1	12.1	5.0	5.0	0.5													
ECQE2153□B()	0.015	7.9	4.2	7.1	12.1	5.0	5.0	0.5													
ECQE2183□B()	0.018	7.9	4.3	7.2	12.2	5.0	5.0	0.5													
ECQE2223□B()	0.022	7.9	4.3	7.2	12.2	5.0	5.0	0.5													
ECQE2273□B()	0.027	7.9	4.3	7.2	12.2	5.0	5.0	0.5													
ECQE2333□B()	0.033	7.9	4.3	7.2	12.2	5.0	5.0	0.5													
ECQE2393□B()	0.039	7.9	4.5	7.4	12.4	5.0	5.0	0.5	1500		-										
ECQE2473□B()	0.047	7.9	4.5	7.4	12.4	5.0	5.0	0.5													
ECQE2563□B()	0.056	7.9	4.7	7.7	12.7	5.0	5.0	0.5													
ECQE2683□B()	0.068	7.9	5.1	8.0	13.0	5.0	5.0	0.5	1000												
ECQE2823□B()	0.082	7.9	5.4	8.6	13.6	5.0	5.0	0.5													
ECQE2104□B()	0.10	7.9	5.9	9.0	14.0	5.0	5.0	0.5													
ECQE2124□B()	0.12	7.9	5.7	10.6	15.6	5.0	5.0	0.5	1500	-											
ECQE2154□B()	0.15	7.9	6.3	11.2	16.2	5.0	5.0	0.5	1000												
ECQE2184□B()	0.18	10.3	5.0	9.7	14.7	7.5	5.0	0.5	1500		1500										
ECQE2224□B()	0.22	10.3	5.4	10.1	15.1	7.5	5.0	0.5													
ECQE2274□B()	0.27	10.3	5.9	10.8	15.8	7.5	5.0	0.5	1000		1000										
ECQE2334□B()	0.33	10.3	6.4	11.3	16.3	7.5	5.0	0.5													
ECQE2394□B()	0.39	12.3	5.7	10.9	15.9	10.0	5.0	0.6													
ECQE2474□B()	0.47	12.3	6.2	11.4	16.4	10.0	5.0	0.6													
ECQE2564□B()	0.56	12.3	6.7	11.9	16.9	10.0	5.0	0.6													
ECQE2684□B()	0.68	12.3	7.3	12.7	17.7	10.0	5.0	0.6													
ECQE2824□B()	0.82	15.3	6.3	13.3	18.3	12.5	5.0	0.6	-		600	500									
ECQE2105□B()	1.0	15.3	7.0	14.0	19.0	12.5	5.0	0.6			500	400									
ECQE2125□B()	1.2	15.3	7.6	14.6	19.6	12.5	5.0	0.6			400	300									
ECQE2155□B()	1.5	15.3	8.6	15.7	20.7	12.5	5.0	0.6			400	300									
ECQE2185□B()	1.8	20.8	7.6	14.6	19.6	17.5	10.0	0.8													
ECQE2225□B()	2.2	20.8	8.4	15.6	20.6	17.5	10.0	0.8			-			400							
ECQE2275□B()	2.7	20.8	9.3	16.7	21.7	17.5	10.0	0.8													
ECQE2335□B()	3.3	20.8	10.5	17.9	22.9	17.5	10.0	0.8									-		300		
ECQE2395□B()	3.9	20.8	10.8	19.8	24.8	17.5	10.0	0.8													
ECQE2475□B()	4.7	20.8	11.9	21.0	26.0	17.5	10.0	0.8			200										

* □ : Capacitance tolerance code
() : Suffix for lead crimped or taped type

Type D : 0.010 μ F to 0.68 μ F
Type B : 0.82 μ F to 4.7 μ F

Rating · Dimensions · Quantity

● Rated voltage : 125 V.AC, Capacitance tolerance : ± 5 %(J), ±10 %(K)

Part No.	Cap. (μF)	Dimensions (mm)							Min. order Q'ty							
		L max.	T max.	H max.		F		S	φd	Taping			Bulk			
				Straight	Crimped lead	Straight	Crimped lead	Standard 5 mm		Odd size 5 mm	Odd size 7.5 mm	Straight - Crimped lead				
ECQE1A103□B()	0.010	7.9	4.2	7.1	-	5.0	-	0.5	2000	-	-	-	500			
ECQE1A123□B()	0.012	7.9	4.2	7.1		5.0		0.5								
ECQE1A153□B()	0.015	7.9	4.2	7.1		5.0		0.5								
ECQE1A183□B()	0.018	7.9	4.3	7.2		5.0		0.5								
ECQE1A223□B()	0.022	7.9	4.3	7.2		5.0		0.5								
ECQE1A273□B()	0.027	7.9	4.3	7.2		5.0		0.5								
ECQE1A333□B()	0.033	7.9	4.3	7.2		5.0		0.5								
ECQE1A393□B()	0.039	7.9	4.5	7.4		5.0		0.5								
ECQE1A473□B()	0.047	7.9	4.8	7.7		5.0		0.5								
ECQE1A563□B()	0.056	7.9	5.1	8.0		5.0		0.5								
ECQE1A683□B()	0.068	7.9	5.4	8.6		5.0		0.5								
ECQE1A823□B()	0.082	10.3	4.6	7.6		12.6		7.5						7.5	0.5	1500
ECQE1A104□B()	0.10	10.3	5.1	7.7	12.7	7.5	7.5	0.5	1000	-	1000	500				
ECQE1A124□B()	0.12	10.3	5.3	8.4	13.4	7.5	7.5	0.5								
ECQE1A154□B()	0.15	10.3	5.7	8.9	13.9	7.5	7.5	0.5								
ECQE1A184□B()	0.18	10.3	5.6	10.3	15.3	7.5	7.5	0.5								
ECQE1A224□B()	0.22	10.3	6.1	11.0	16.0	7.5	7.5	0.5								
ECQE1A274□B()	0.27	12.3	5.4	10.7	15.7	10.0	7.5	0.6					800			
ECQE1A334□B()	0.33	12.3	5.9	11.2	16.2	10.0	7.5	0.6					700			
ECQE1A394□B()	0.39	12.3	6.4	11.6	16.6	10.0	7.5	0.6					600			
ECQE1A474□B()	0.47	12.3	7.0	12.2	17.2	10.0	7.5	0.6					500	900		
ECQE1A564□B()	0.56	12.3	6.7	11.9	16.9	10.0	7.5	0.6					600	1000		
ECQE1A684□B()	0.68	12.3	7.3	12.7	17.7	10.0	7.5	0.6					500	900		
ECQE1A824□B()	0.82	15.3	6.3	13.3	18.3	12.5	7.5	0.6					600	500		
ECQE1A105□B()	1.0	15.3	7.0	14.0	19.0	12.5	7.5	0.6	500	400						
ECQE1A125□B()	1.2	20.8	7.1	14.1	19.1	17.5	10.0	0.8	-	500	400	500				
ECQE1A155□B()	1.5	20.8	8.0	15.1	20.1	17.5	10.0	0.8								
ECQE1A185□B()	1.8	20.8	8.7	15.9	20.9	17.5	10.0	0.8								
ECQE1A225□B()	2.2	20.8	9.7	17.1	22.1	17.5	10.0	0.8								
ECQE1A275□B()	2.7	20.8	10.9	18.2	23.2	17.5	10.0	0.8								
ECQE1A335□B()	3.3	25.8	9.6	18.7	23.7	22.5	15.0	0.8								
ECQE1A395□B()	3.9	25.8	10.6	19.7	24.7	22.5	15.0	0.8								
ECQE1A475□B()	4.7	25.8	11.8	20.8	25.8	22.5	15.0	0.8								

* □ : Capacitance tolerance code
() : Suffix for lead crimped or taped type

Type D : 0.082 μF to 0.68 μF
Type B : 0.82 μF to 4.7 μF

Notice for AC rated

AC rated capacitors complying with clause 1 of "Electrical Appliance and Material Safety Law".
As for clause 2 of "Electrical Appliance and Material Safety Law", please use ECQUA type or ECQUL type.

When using these capacitors as a across-the-line capacitor, it shall be required to follow either item 1. or item 2. condition.

1. Capacitor shall be connected in parallel with varistor (Specified varistor voltage in table 1.)
2. Voltage applied for capacitor shall not exceed other than specified in table 1, when using these capacitors.

Table 1

Capacitor rated voltage	Varistor voltage	Pulse voltage
125 V.AC	250 V	250 V _{0,P}

Metallized Polyester Film Capacitor

Series : **ECQE(T)**

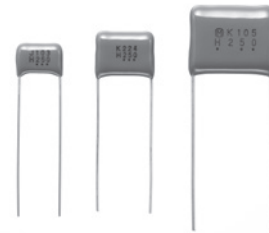

Non-inductive construction using metallized Polyester film with flame retardant epoxy resin coating

Features

- Self-healing property
- Excellent electrical characteristics
- Flame retardant epoxy resin coating
- Moisture resistance 85 °C, 85 % RH for 500 hours
- RoHS directive compliant

Recommended applications

- General purpose usage
 - * Please contact us when applications are CDI , ignitor etc.

Explanation of part number

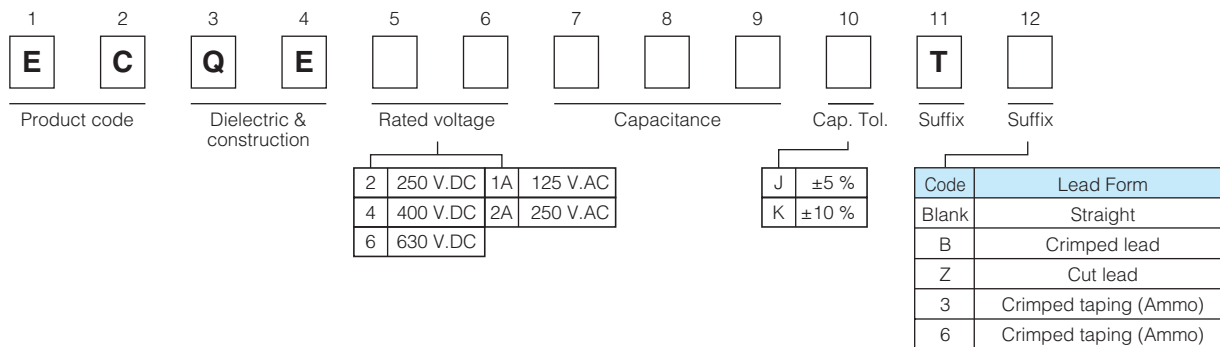

- Odd size taping

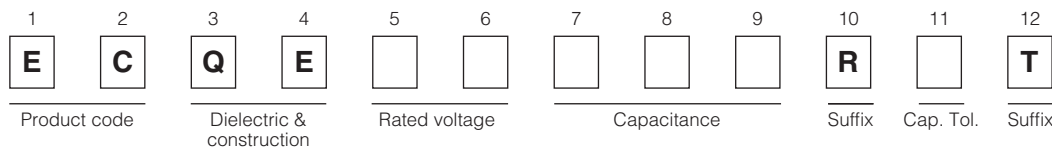

Specifications

Category temp. range (Including temperature-rise on unit surface)	250 V.DC, 400 V.DC, 630 V.DC	- 40 °C to +105 °C
	125 V.AC, 250 V.AC	- 40 °C to +105 °C
Rated voltage	250 V.DC, 400 V.DC, 630 V.DC (Derating of rated voltage by 1.25 %/°C at more than 85 °C) 125 V.AC, 250 V.AC	
Capacitance range	250 V.DC	0.010 μF to 10.0 μF (E12)
	400 V.DC	0.010 μF to 2.2 μF (E12)
	630 V.DC	0.010 μF to 2.2 μF (E12)
	125 V.AC	0.010 μF to 0.47 μF (E12)
	250 V.AC	0.010 μF to 0.47 μF (E12)
Capacitance tolerance	±5 % (J), ±10 % (K)	
Dissipation factor (tan δ)	tan δ ≤ 1.0 % (20 °C, 1 kHz)	
Withstand voltage	• Rated volt. : 250 V.DC to 630 V.DC Between terminals : Rated volt. (V.DC) × 150 %, 60 s	
	• Rated volt. : 125 V.AC, 250 V.AC Between terminals : Rated volt. (V.AC) × 230 %, 60 s Between terminals to enclosure : 1500 V.AC, 60 s	
Insulation resistance (IR)	250 V.DC to 630 V.DC : C ≤ 0.33 μF : IR ≥ 9000 MΩ C > 0.33 μF : IR ≥ 3000 MΩ · μF (20 °C, 100 V.DC, 60 s)	
	125 V.AC, 250 V.AC : IR ≥ 2000 MΩ (20 °C, 500 V.DC, 60 s)	

* In case of applying voltage in alternating current (50 Hz or 60 Hz sine wave) to a capacitor with DC rated voltage, please refer to the page of "Permissible voltage (R.M.S) in alternating current corresponding to DC rated voltage".
 * Voltage to be applied to ECQE1A (T) & ECQE2A (T) is only sine wave (50 Hz or 60 Hz).

Dimensions

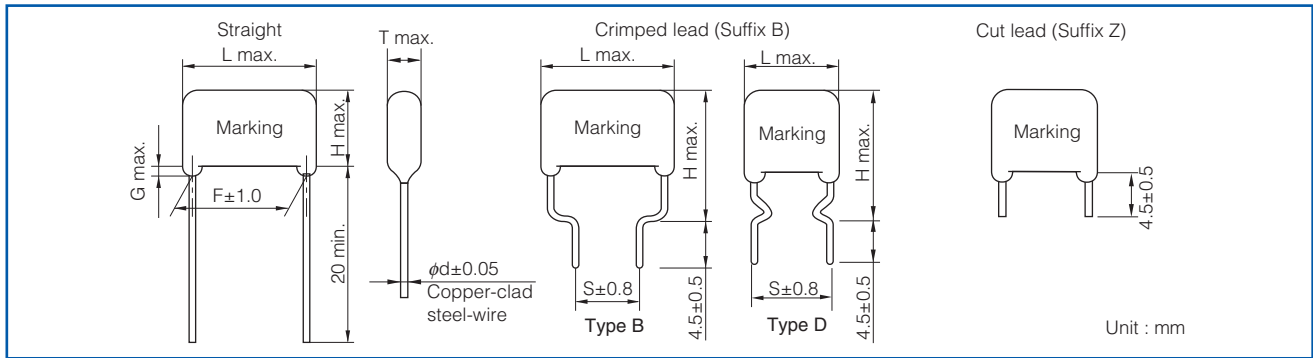

Packaging specifications for bulk package

- Packing quantity : 100 pcs./bag

Taping specifications for automatic insertion

- Taping style

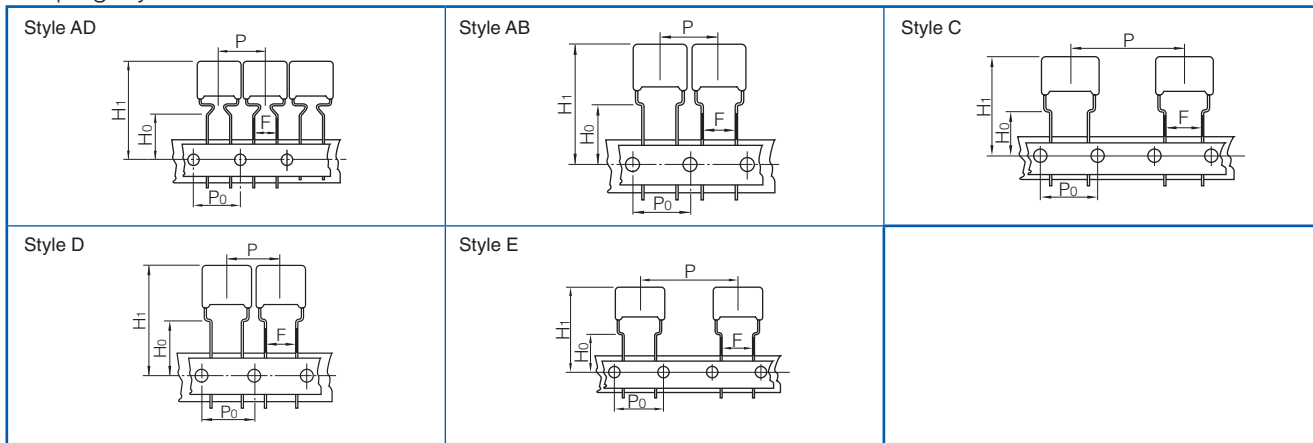

* Refer to the page of taping specifications.

- Packaging specifications

Series	Rated voltage	Capacitance range (μF)	Taping style					Packing	suffix
			AD	AB	C	D	E		
ECQE(T)	250 V.DC	0.010 to 0.15	○					Ammo	() T3
		0.18 to 0.33			○			Ammo	() T3
		0.39 to 1.5			○			Ammo	() T3
		0.010 to 0.33				○		Ammo	R() T
		0.39 to 1.5					○	Ammo	R() T
	400 V.DC	0.010 to 0.033	○					Ammo	() T3
		0.039 to 0.10			○			Ammo	() T3
		0.12 to 0.47			○			Ammo	() T3
		0.010 to 0.10				○		Ammo	R() T
		0.12 to 0.47					○	Ammo	R() T
	630 V.DC	0.010 to 0.047			○			Ammo	() T3
		0.056 to 0.22			○			Ammo	() T3
		0.010 to 0.047				○		Ammo	R() T
		0.056 to 0.22					○	Ammo	R() T
	125 V.AC	0.27 to 0.47			○			Ammo	() T3
		0.010 to 0.10		○				Ammo	() T6
0.12 to 0.22				○			Ammo	() T6	
0.010 to 0.22					○		Ammo	R() T	
0.27 to 0.47						○	Ammo	R() T	
250 V.AC	0.056 to 0.22			○		○	Ammo	() T3	
	0.010 to 0.047			○			Ammo	() T6	
	0.010 to 0.047				○		Ammo	R() T	
	0.056 to 0.22					○	Ammo	R() T	

- Lead spacing

Style	Lead spacing
AD	5.0 mm
AB	5.0 mm
C	5.0 mm
D	7.5 mm
E	7.5 mm

* See the column "Rating · Dimensions · Quantity" for packing quantity

Rating · Dimensions · Quantity

● Rated voltage : 250 V.DC, Capacitance tolerance : ± 5 % (J), ±10 % (K)

Part No.	Cap. (μ F)	Dimensions (mm)								Min. order Q'ty														
		L max.	T max.	H max.		F		S		G max.	ϕ d	Taping			Bulk									
				Straight	Crimped lead	Straight	Crimped lead	Straight	Crimped lead			Straight	Crimped lead	Straight	Crimped lead									
ECQE2103□T()	0.010	10.8	4.3	7.4	12.4	7.5	7.5	1.0	0.6	1500	-	-	1800	500	500									
ECQE2123□T()	0.012	10.8	4.4	7.5	12.5	7.5	7.5	1.0	0.6				1700											
ECQE2153□T()	0.015	10.8	4.4	7.5	12.5	7.5	7.5	1.0	0.6				1700											
ECQE2183□T()	0.018	10.8	4.4	7.5	12.5	7.5	7.5	1.0	0.6				1700											
ECQE2223□T()	0.022	10.8	4.4	7.5	12.5	7.5	7.5	1.0	0.6				1700											
ECQE2273□T()	0.027	10.8	4.4	7.5	12.5	7.5	7.5	1.0	0.6				1700											
ECQE2333□T()	0.033	10.8	4.5	7.5	12.5	7.5	7.5	1.0	0.6				1700											
ECQE2393□T()	0.039	10.8	4.5	7.5	12.5	7.5	7.5	1.0	0.6				1700											
ECQE2473□T()	0.047	10.8	4.5	7.5	12.5	7.5	7.5	1.0	0.6				1700											
ECQE2563□T()	0.056	10.8	4.8	7.9	12.9	7.5	7.5	1.0	0.6				1600											
ECQE2683□T()	0.068	10.8	4.5	7.5	12.5	7.5	7.5	1.0	0.6				1700											
ECQE2823□T()	0.082	10.8	4.9	8.0	13.0	7.5	7.5	1.0	0.6				1500											
ECQE2104□T()	0.10	10.8	5.8	8.4	13.4	7.5	7.5	1.0	0.6				1000			-	-	1300	500	500				
ECQE2124□T()	0.12	10.8	6.0	9.0	14.0	7.5	7.5	1.0	0.6									1200						
ECQE2154□T()	0.15	10.8	6.0	10.8	15.8	7.5	7.5	1.0	0.6									1200						
ECQE2184□T()	0.18	12.5	5.0	10.3	15.3	10.0	10.0	1.0	0.6	-	-	-	800	1400	500	500								
ECQE2224□T()	0.22	12.5	5.5	10.5	15.5	10.0	10.0	1.0	0.6				1300											
ECQE2274□T()	0.27	12.5	6.0	11.5	16.5	10.0	10.0	1.0	0.6				700	1200										
ECQE2334□T()	0.33	12.5	6.5	12.0	17.0	10.0	10.0	1.0	0.6				600	1100										
ECQE2394□T()	0.39	19.0	4.9	12.0	17.0	15.0	10.0	1.0	0.6				800	700										
ECQE2474□T()	0.47	19.0	5.3	12.5	17.5	15.0	10.0	1.0	0.6				700	600										
ECQE2564□T()	0.56	19.0	5.5	13.0	18.0	15.0	10.0	1.0	0.6				800											
ECQE2684□T()	0.68	19.0	6.0	13.5	18.5	15.0	10.0	1.0	0.8				700											
ECQE2824□T()	0.82	19.0	6.5	14.5	19.5	15.0	10.0	1.0	0.8				600	500										
ECQE2105□T()	1.0	19.0	7.4	15.0	20.0	15.0	10.0	1.0	0.8				500	400			-	-	500	500				
ECQE2125□T()	1.2	19.0	8.0	15.9	20.9	15.0	10.0	1.0	0.8															
ECQE2155□T()	1.5	19.0	9.0	16.8	21.8	15.0	10.0	1.0	0.8												400			
ECQE2185□T()	1.8	26.5	7.5	15.5	20.5	22.5	15.0	1.0	0.8				-	-							-	-	500	500
ECQE2225□T()	2.2	26.5	8.5	16.3	21.3	22.5	15.0	1.0	0.8															
ECQE2275□T()	2.7	26.5	9.4	17.0	22.0	22.5	15.0	1.0	0.8															
ECQE2335□T()	3.3	26.5	10.3	18.0	23.0	22.5	15.0	1.5	0.8															
ECQE2395□T()	3.9	26.5	11.0	20.5	25.5	22.5	15.0	1.5	0.8															
ECQE2475□T()	4.7	26.5	12.0	21.5	26.5	22.5	15.0	1.5	0.8															
ECQE2565□T()	5.6	31.5	11.8	21.0	26.0	27.5	22.5	1.5	0.8															
ECQE2685□T()	6.8	31.5	13.0	22.4	27.4	27.5	22.5	1.5	0.8															
ECQE2825□T()	8.2	31.5	14.3	23.5	28.5	27.5	22.5	1.5	0.8	400														
ECQE2106□T()	10.0	31.5	15.9	25.8	30.8	27.5	22.5	1.5	0.8	300	400													

* □ : Capacitance tolerance code
() : Suffix for lead crimped or taped type

Type D : 0.010 μ F to 0.33 μ F
Type B : 0.39 μ F to 10.0 μ F

Rating · Dimensions · Quantity

● Rated voltage : 400 V.DC, Capacitance tolerance : ± 5 % (J), ±10 % (K)

Part No.	Cap. (μF)	Dimensions (mm)								Min. order Q'ty				
		L max.	T max.	H max.		F	S	G max.	φd	Taping			Bulk Straight · Crimped lead	
				Straight	Crimped lead					Standard 5 mm	Odd size 5 mm	Odd size 7.5 mm		
ECQE4103□()	0.010	10.8	4.3	7.4	12.4	7.5	7.5	1.0	0.6	1500	-	1800	500	
ECQE4123□()	0.012	10.8	4.4	7.5	12.5	7.5	7.5	1.0	0.6			1700		
ECQE4153□()	0.015	10.8	4.4	7.5	12.5	7.5	7.5	1.0	0.6			1600		
ECQE4183□()	0.018	10.8	4.4	7.5	12.5	7.5	7.5	1.0	0.6			1400		
ECQE4223□()	0.022	10.8	4.8	7.9	12.9	7.5	7.5	1.0	0.6			1200		
ECQE4273□()	0.027	10.8	5.5	8.0	13.0	7.5	7.5	1.0	0.6			900		1500
ECQE4333□()	0.033	10.8	6.0	9.0	14.0	7.5	7.5	1.0	0.6	-	-	1400	500	
ECQE4393□()	0.039	12.5	4.9	8.0	13.0	10.0	10.0	1.0	0.6			1300		
ECQE4473□()	0.047	12.5	5.0	8.3	13.3	10.0	10.0	1.0	0.6			1200		
ECQE4563□()	0.056	12.5	5.0	10.0	15.0	10.0	10.0	1.0	0.6			800		1400
ECQE4683□()	0.068	12.5	5.4	10.5	15.5	10.0	10.0	1.0	0.6			700		1200
ECQE4823□()	0.082	12.5	5.8	11.0	16.0	10.0	10.0	1.0	0.6			800		700
ECQE4104□()	0.10	12.5	6.3	12.0	17.0	10.0	10.0	1.0	0.6			700		600
ECQE4124□()	0.12	19.0	5.0	10.0	15.0	10.0	10.0	1.0	0.6			600		500
ECQE4154□()	0.15	19.0	5.0	12.4	17.4	15.0	10.0	1.0	0.6			500		400
ECQE4184□()	0.18	19.0	5.4	12.5	17.5	15.0	10.0	1.0	0.6			400		
ECQE4224□()	0.22	19.0	5.9	13.0	18.0	15.0	10.0	1.0	0.6					
ECQE4274□()	0.27	19.0	6.5	14.3	19.3	15.0	10.0	1.0	0.8					
ECQE4334□()	0.33	19.0	7.0	14.9	19.9	15.0	10.0	1.0	0.8					
ECQE4394□()	0.39	19.0	7.5	15.4	20.4	15.0	10.0	1.0	0.8					
ECQE4474□()	0.47	19.0	7.8	17.0	22.0	15.0	10.0	1.0	0.8					
ECQE4564□()	0.56	26.5	6.5	16.0	21.0	22.5	15.0	1.0	0.8					
ECQE4684□()	0.68	26.5	7.0	16.5	21.5	22.5	15.0	1.0	0.8					
ECQE4824□()	0.82	26.5	7.9	17.3	22.3	22.5	15.0	1.0	0.8					
ECQE4105□()	1.0	26.5	8.5	18.0	23.0	22.5	15.0	1.0	0.8					
ECQE4125□()	1.2	26.5	9.5	18.9	23.9	22.5	15.0	1.0	0.8					
ECQE4155□()	1.5	31.5	9.5	19.0	24.0	27.5	22.5	1.0	0.8					
ECQE4185□()	1.8	31.5	11.0	20.5	25.5	27.5	22.5	1.5	0.8					
ECQE4225□()	2.2	31.5	11.0	22.0	27.0	27.5	22.5	1.5	0.8					

* □ : Capacitance tolerance code
() : Suffix for lead crimped or taped type

Type D : 0.010 μF to 0.10 μF
Type B : 0.12 μF to 2.2 μF

● Rated voltage : 630 V.DC, Capacitance tolerance : ± 5 % (J), ±10 % (K)

Part No.	Cap. (μF)	Dimensions (mm)								Min. order Q'ty				
		L max.	T max.	H max.		F	S	G max.	φd	Taping		Bulk		
				Straight	Crimped lead					Odd size 5 mm	Odd size 7.5 mm	Straight	Crimped lead	
ECQE6103□()	0.010	12.5	4.5	7.5	12.5	10.0	10.0	1.0	0.6	900	1600	500	500	
ECQE6123□()	0.012	12.5	4.5	7.8	12.8	10.0	10.0	1.0	0.6					1400
ECQE6153□()	0.015	12.5	5.0	8.2	13.2	10.0	10.0	1.0	0.6					1300
ECQE6183□()	0.018	12.5	4.9	10.0	15.0	10.0	10.0	1.0	0.6					1200
ECQE6223□()	0.022	12.5	5.3	10.5	15.5	10.0	10.0	1.0	0.6					1100
ECQE6273□()	0.027	12.5	5.5	10.9	15.9	10.0	10.0	1.0	0.6					800
ECQE6333□()	0.033	12.5	6.0	11.9	16.9	10.0	10.0	1.0	0.6	-	-	600	500	
ECQE6393□()	0.039	12.5	6.0	13.4	18.4	10.0	10.0	1.0	0.6			700		1200
ECQE6473□()	0.047	12.5	6.5	13.5	18.5	10.0	10.0	1.0	0.6			600		1100
ECQE6563□()	0.056	19.0	5.4	10.5	15.5	15.0	10.0	1.0	0.6			800		600
ECQE6683□()	0.068	19.0	5.8	11.0	16.0	15.0	10.0	1.0	0.6			700		600
ECQE6823□()	0.082	19.0	6.5	12.0	17.0	15.0	10.0	1.0	0.6			600		500
ECQE6104□()	0.10	19.0	6.3	14.0	19.0	15.0	10.0	1.0	0.6			500		400
ECQE6124□()	0.12	19.0	6.3	14.5	19.5	15.0	10.0	1.0	0.8			400		
ECQE6154□()	0.15	19.0	7.5	15.4	20.4	15.0	10.0	1.0	0.8					
ECQE6184□()	0.18	19.0	8.0	16.0	21.0	15.0	10.0	1.0	0.8					
ECQE6224□()	0.22	19.0	9.0	16.5	21.5	15.0	10.0	1.0	0.8					
ECQE6274□()	0.27	26.5	7.0	16.5	21.5	22.5	15.0	1.0	0.8					
ECQE6334□()	0.33	26.5	7.8	17.0	22.0	22.5	15.0	1.0	0.8					
ECQE6394□()	0.39	26.5	8.5	17.9	22.9	22.5	15.0	1.0	0.8					
ECQE6474□()	0.47	26.5	9.3	18.5	23.5	22.5	15.0	1.0	0.8					
ECQE6564□()	0.56	26.5	10.0	20.0	25.0	22.5	15.0	1.5	0.8					
ECQE6684□()	0.68	26.5	11.5	21.0	26.0	22.5	15.0	1.5	0.8					
ECQE6824□()	0.82	31.5	11.3	20.5	25.5	27.5	22.5	1.5	0.8					
ECQE6105□()	1.0	31.5	12.5	21.9	26.9	27.5	22.5	1.5	0.8					
ECQE6125□()	1.2	31.5	13.5	23.0	28.0	27.5	22.5	1.5	0.8					
ECQE6155□()	1.5	31.5	15.3	24.7	29.7	27.5	22.5	1.5	0.8					
ECQE6185□()	1.8	31.5	16.8	27.0	32.0	27.5	22.5	1.5	0.8					
ECQE6225□()	2.2	31.5	19.5	29.0	34.0	27.5	22.5	1.5	0.8					

* □ : Capacitance tolerance code
() : Suffix for lead crimped or taped type

Type D : 0.010 μF to 0.047 μF
Type B : 0.056 μF to 2.2 μF

Rating · Dimensions · Quantity

- Rated voltage : 125 V.AC, Capacitance tolerance : $\pm 5\%$ (J), $\pm 10\%$ (K)
Noise suppression Capacitors (Across-the-line)

Part No.	Cap. (μ F)	Dimensions (mm)								Min. order Q'ty				
		L max.	T max.	H max.		F		S	G max.	ϕ d	Taping			Bulk Straight · Crimped lead
				Straight	Crimped lead	Straight	Crimped lead	Straight	Standard 5 mm		Odd size 5 mm	Odd size 7.5 mm		
ECQE1A103□□()	0.010	11.0	4.5	7.5	12.5	7.5	7.5	1.0	0.6	1500	-	1700	500	
ECQE1A123□□()	0.012	11.0	4.4	7.5	12.5	7.5	7.5	1.0	0.6					
ECQE1A153□□()	0.015	11.0	4.4	7.5	12.5	7.5	7.5	1.0	0.6					
ECQE1A183□□()	0.018	11.0	4.4	7.5	12.5	7.5	7.5	1.0	0.6					
ECQE1A223□□()	0.022	11.0	4.4	7.5	12.5	7.5	7.5	1.0	0.6					
ECQE1A273□□()	0.027	11.0	4.4	7.5	12.5	7.5	7.5	1.0	0.6					
ECQE1A333□□()	0.033	11.0	4.5	7.8	12.8	7.5	7.5	1.0	0.6					
ECQE1A393□□()	0.039	11.0	4.5	7.8	12.8	7.5	7.5	1.0	0.6					
ECQE1A473□□()	0.047	11.0	5.5	8.0	13.0	7.5	7.5	1.0	0.6					
ECQE1A563□□()	0.056	11.0	5.9	8.5	13.5	7.5	7.5	1.0	0.6					
ECQE1A683□□()	0.068	11.0	6.3	9.4	14.4	7.5	7.5	1.0	0.6					
ECQE1A823□□()	0.082	11.0	6.5	9.8	14.8	7.5	7.5	1.0	0.6					
ECQE1A104□□()	0.10	11.0	6.5	11.8	16.8	7.5	7.5	1.0	0.6					
ECQE1A124□□()	0.12	13.0	5.9	11.5	16.5	10.0	10.0	1.0	0.6					
ECQE1A154□□()	0.15	13.0	6.5	12.0	17.0	10.0	10.0	1.0	0.6					
ECQE1A184□□()	0.18	13.0	7.0	12.5	17.5	10.0	10.0	1.0	0.6					
ECQE1A224□□()	0.22	13.0	7.5	13.4	18.4	10.0	10.0	1.0	0.6					
ECQE1A274□□()	0.27	19.0	6.3	12.0	17.0	15.0	10.0	1.0	0.6					
ECQE1A334□□()	0.33	19.0	6.9	12.5	17.5	15.0	10.0	1.0	0.6					
ECQE1A394□□()	0.39	19.0	7.4	13.0	18.0	15.0	10.0	1.0	0.6					
ECQE1A474□□()	0.47	19.0	7.5	15.3	20.3	15.0	10.0	1.0	0.6					

* □ : Capacitance tolerance code
() : Suffix for lead crimped or taped type

Type D : 0.010 μ F to 0.22 μ F
Type B : 0.27 μ F to 0.47 μ F

- Rated voltage : 250 V.AC, Capacitance tolerance : $\pm 5\%$ (J), $\pm 10\%$ (K)
Noise suppression Capacitors (Across-the-line)

Part No.	Cap. (μ F)	Dimensions (mm)								Min. order Q'ty				
		L max.	T max.	H max.		F		S	G max.	ϕ d	Taping			Bulk Straight · Crimped lead
				Straight	Crimped lead	Straight	Crimped lead	Straight	Odd size 5 mm		Odd size 7.5 mm	Standard 5 mm		
ECQE2A103□□()	0.010	13.0	5.5	10.8	15.8	10.0	10.0	1.0	0.6	500	-	800	1300	
ECQE2A123□□()	0.012	13.0	6.0	11.5	16.5	10.0	10.0	1.0	0.6					
ECQE2A153□□()	0.015	13.0	6.3	9.9	14.9	10.0	10.0	1.0	0.6					
ECQE2A183□□()	0.018	13.0	6.0	11.9	16.9	10.0	10.0	1.0	0.6					
ECQE2A223□□()	0.022	13.0	6.0	11.5	16.5	10.0	10.0	1.0	0.6					
ECQE2A273□□()	0.027	13.0	5.5	10.9	15.9	10.0	10.0	1.0	0.6					
ECQE2A333□□()	0.033	13.0	6.0	11.9	16.9	10.0	10.0	1.0	0.6					
ECQE2A393□□()	0.039	13.0	6.0	13.4	18.4	10.0	10.0	1.0	0.6					
ECQE2A473□□()	0.047	13.0	6.5	14.4	19.4	10.0	10.0	1.0	0.6					
ECQE2A563□□()	0.056	19.0	5.4	10.5	15.5	15.0	10.0	1.0	0.6					
ECQE2A683□□()	0.068	19.0	5.8	11.0	16.0	15.0	10.0	1.0	0.6					
ECQE2A823□□()	0.082	19.0	6.3	12.0	17.0	15.0	10.0	1.0	0.6					
ECQE2A104□□()	0.10	19.0	6.3	14.0	19.0	15.0	10.0	1.0	0.6					
ECQE2A124□□()	0.12	19.0	6.8	14.5	19.5	15.0	10.0	1.0	0.8					
ECQE2A154□□()	0.15	19.0	7.5	15.4	20.4	15.0	10.0	1.0	0.8					
ECQE2A184□□()	0.18	19.0	8.0	16.0	21.0	15.0	10.0	1.0	0.8					
ECQE2A224□□()	0.22	19.0	9.0	16.9	21.9	15.0	10.0	1.0	0.8					
ECQE2A274□□()	0.27	26.5	7.0	16.5	21.5	22.5	15.0	1.0	0.8					
ECQE2A334□□()	0.33	26.5	7.8	17.0	22.0	22.5	15.0	1.0	0.8					
ECQE2A394□□()	0.39	26.5	8.5	17.9	22.9	22.5	15.0	1.0	0.8					
ECQE2A474□□()	0.47	26.5	9.3	18.5	23.5	22.5	15.0	1.0	0.8					

* □ : Capacitance tolerance code
() : Suffix for lead crimped or taped type

Type D : 0.010 μ F to 0.047 μ F
Type B : 0.056 μ F to 0.47 μ F

Notice for AC rated

AC rated capacitors complying with clause 1 of "Electrical Appliance and Material Safety Law".

As for clause 2 of "Electrical Appliance and Material Safety Law", please use ECQUA type or ECQUL type.

When using these capacitors as a across-the-line capacitor, it shall be required to follow either item 1. or item 2. condition.

1. Capacitor shall be connected in parallel with varistor (Specified varistor voltage in table 1.)
2. Voltage applied for capacitor shall not exceed other than specified in table 1, when using these capacitors.

Table 1

Capacitor rated voltage	Varistor voltage	Pulse voltage
125 V.AC	250 V	250 V _{D,P}
250 V.AC	470 V	630 V _{D,P}

Metallized Polypropylene Film Capacitor

Series : **ECWF(L)**

Non-inductive construction using metallized polypropylene film with flame retardant epoxy resin coating.

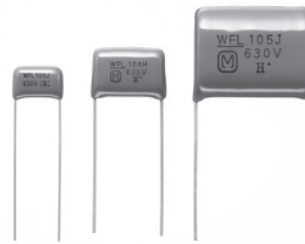

Features

- Small size
- Excellent frequency characteristics
- Low loss
- Flame retardant epoxy resin coating
- 85 °C, 85 % RH, W.V. × 1.0 for 500 hours
- RoHS directive compliant

Recommended applications

- Lighting
- High frequency and high current circuit

Explanation of part number

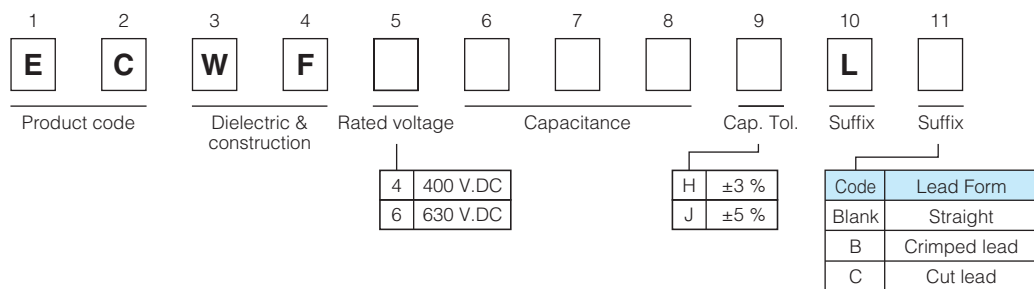

- Odd size taping

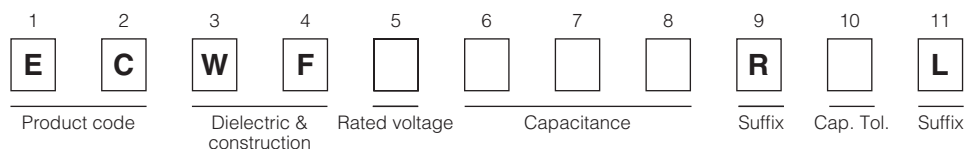

Specifications

Category temp. range (Including temperature-rise on unit surface)	- 40 °C to +105 °C	
Rated voltage	400 V.DC, 630 V.DC	
Capacitance range	400 V.DC	0.022 μF to 2.4 μF
	630 V.DC	0.010 μF to 1.3 μF
Capacitance tolerance	±3 % (H), ±5 % (J)	
Dissipation factor (tan δ)	tan δ ≤ 0.05 % (20 °C, 1 kHz) tan δ ≤ 0.20 % (20 °C, 10 kHz)	
Withstand voltage	Between terminals : Rated volt. (V.DC) × 150 %, 60 s	
Insulation resistance (IR)	C ≤ 0.33 μF : IR ≥ 9000 MΩ (20 °C, 100 V.DC, 60 s for 400 V.DC)	
	C > 0.33 μF : IR ≥ 3000 MΩ · μF (20 °C, 500 V.DC, 60 s for 630 V.DC)	

* In case of applying voltage in alternating current (50 Hz or 60 Hz sine wave) to a capacitor with DC rated voltage, please refer to the page of "Permissible voltage (R.M.S) in alternating current corresponding to DC rated voltage".

Dimensions

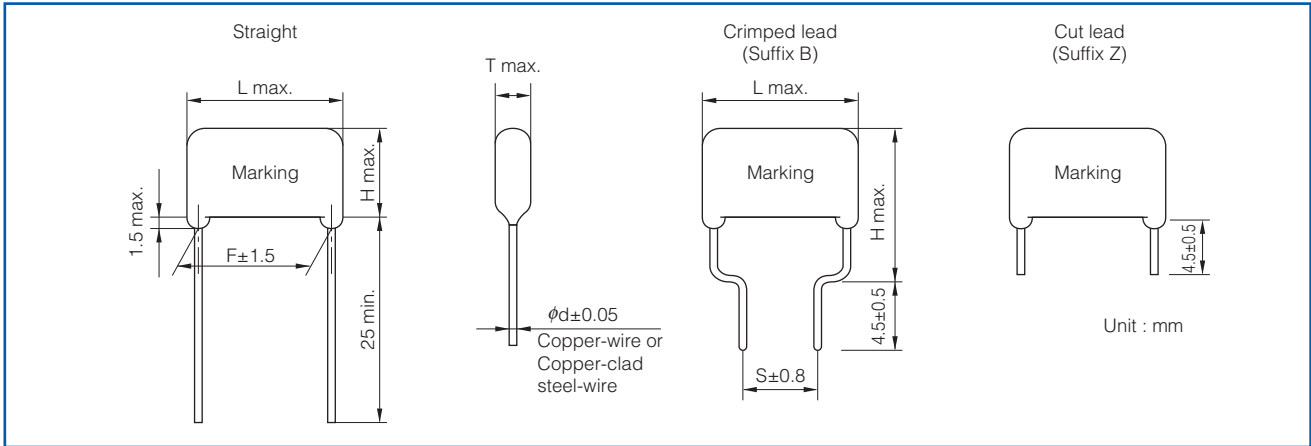

Packaging specifications for bulk package

- Packing quantity : 100 pcs./bag

Taping specifications for automatic insertion

- Taping style

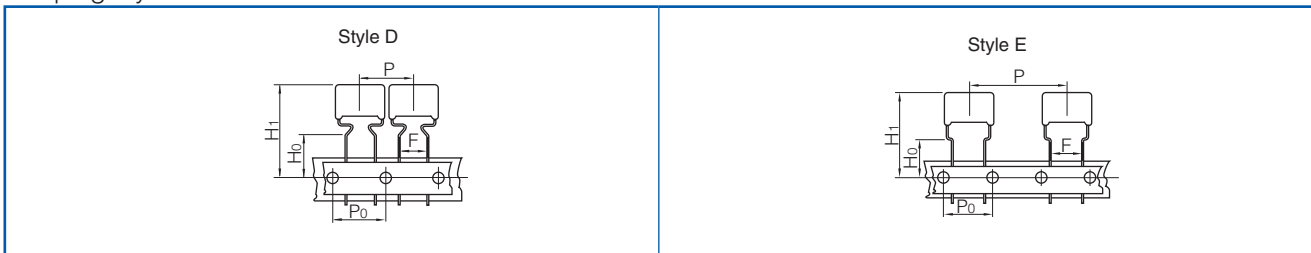

* Refer to the page of taping specifications.

- Packaging specifications

Series	Rated voltage (V.DC)	Capacitance range (μF)	Taping style					Packing	suffix
			AD	AB	C	D	E		
ECWF(L)	400	0.022 to 0.091				○		Ammo	R() L
		0.10 to 1.0					○	Ammo	R() L
	630	0.010 to 0.043				○		Ammo	R() L
		0.047 to 0.43					○	Ammo	R() L

- Lead spacing

Style	Lead spacing
D	7.5 mm
E	7.5 mm

Rating · Dimensions · Quantity

● Rated voltage : 400 V.DC, Capacitance tolerance : ± 3 %(J), ±5 %(J)

Part No.	Cap. (μ F)	Dimensions (mm)							Min. order Q'ty			
		L max.	T max.	H max.		F		S	ϕ d	Taping	Bulk	
				Straight	Crimped lead	Straight	Crimped lead	7.5 mm		Straight	Crimped lead	
ECWF4223□L()	0.022	12.5	5.8	8.6	13.6	10.0	7.5	0.6	1100	500	500	
ECWF4243□L()	0.024	12.5	6.0	8.8	13.8	10.0	7.5	0.6				
ECWF4273□L()	0.027	12.5	6.2	9.0	14.0	10.0	7.5	0.6	1000			
ECWF4303□L()	0.030	12.5	6.4	9.3	14.3	10.0	7.5	0.6				
ECWF4333□L()	0.033	12.5	6.7	9.5	14.5	10.0	7.5	0.6	900			
ECWF4363□L()	0.036	12.5	5.7	8.4	13.4	10.0	7.5	0.6				
ECWF4393□L()	0.039	12.5	5.8	8.6	13.6	10.0	7.5	0.6	1100			
ECWF4433□L()	0.043	12.5	6.0	8.8	13.8	10.0	7.5	0.6				
ECWF4473□L()	0.047	12.5	6.2	9.0	14.0	10.0	7.5	0.6	1000			
ECWF4513□L()	0.051	12.5	6.4	9.2	14.2	10.0	7.5	0.6				
ECWF4563□L()	0.056	12.5	6.6	9.4	14.4	10.0	7.5	0.6	900			
ECWF4623□L()	0.062	13.0	6.8	9.6	14.6	10.0	7.5	0.8				
ECWF4683□L()	0.068	13.0	7.0	9.9	14.9	10.0	7.5	0.8	800			
ECWF4753□L()	0.075	13.0	7.3	10.1	15.1	10.0	7.5	0.8				
ECWF4823□L()	0.082	13.0	7.5	10.4	15.4	10.0	7.5	0.8	500			
ECWF4913□L()	0.091	13.0	7.8	10.7	15.7	10.0	7.5	0.8				
ECWF4104□L()	0.10	15.5	6.5	11.0	16.0	12.5	7.5	0.8	400			
ECWF4114□L()	0.11	15.5	6.8	11.3	16.3	12.5	7.5	0.8				
ECWF4124□L()	0.12	15.5	7.0	11.5	16.5	12.5	7.5	0.8	300			
ECWF4134□L()	0.13	15.5	7.2	11.8	16.8	12.5	7.5	0.8				
ECWF4154□L()	0.15	15.5	7.6	12.2	17.2	12.5	7.5	0.8	200			
ECWF4164□L()	0.16	15.5	7.8	12.4	17.4	12.5	7.5	0.8				
ECWF4184□L()	0.18	15.5	8.2	12.8	17.8	12.5	7.5	0.8	300			
ECWF4204□L()	0.20	15.5	8.6	13.3	18.3	12.5	7.5	0.8				
ECWF4224□L()	0.22	15.5	9.0	13.6	18.6	12.5	7.5	0.8	200			
ECWF4244□L()	0.24	18.0	8.3	13.0	18.0	15.0	10.0	0.8				
ECWF4274□L()	0.27	18.0	8.8	13.4	18.4	15.0	10.0	0.8	200			
ECWF4304□L()	0.30	18.0	9.2	13.9	18.9	15.0	10.0	0.8				
ECWF4334□L()	0.33	18.0	9.6	14.3	19.3	15.0	10.0	0.8	200			
ECWF4364□L()	0.36	18.0	9.9	14.7	19.7	15.0	10.0	0.8				
ECWF4394□L()	0.39	18.0	10.3	15.1	20.1	15.0	10.0	0.8	200			
ECWF4434□L()	0.43	18.0	10.7	15.6	20.6	15.0	10.0	0.8				
ECWF4474□L()	0.47	18.0	11.2	16.1	21.1	15.0	10.0	0.8	200			
ECWF4514□L()	0.51	20.5	10.3	16.8	21.8	17.5	12.5	0.8				
ECWF4564□L()	0.56	20.5	10.7	17.3	22.3	17.5	12.5	0.8	200			
ECWF4624□L()	0.62	20.5	11.3	17.9	22.9	17.5	12.5	0.8				
ECWF4684□L()	0.68	20.5	11.8	18.5	23.5	17.5	12.5	0.8	200			
ECWF4754□L()	0.75	20.5	12.3	19.1	24.1	17.5	12.5	0.8				
ECWF4824□L()	0.82	23.0	11.8	18.5	23.5	20.0	12.5	0.8	200			
ECWF4914□L()	0.91	23.0	12.4	19.2	24.2	20.0	12.5	0.8				
ECWF4105□L()	1.0	23.0	13.0	19.8	24.8	20.0	12.5	0.8	-			
ECWF4115□L()	1.1	23.0	13.6	20.5	25.5	20.0	12.5	0.8				
ECWF4125□L()	1.2	28.0	12.3	19.1	24.1	25.0	17.5	0.8	400			
ECWF4135□L()	1.3	28.0	12.8	19.6	24.6	25.0	17.5	0.8				
ECWF4155□L()	1.5	28.0	13.7	20.7	25.7	25.0	17.5	0.8	400			
ECWF4165□L()	1.6	28.0	14.2	21.2	26.2	25.0	17.5	0.8				
ECWF4185□L()	1.8	28.0	15.2	22.2	27.2	25.0	17.5	0.8	400			
ECWF4205□L()	2.0	28.0	16.0	23.1	28.1	25.0	17.5	0.8				
ECWF4225□L()	2.2	28.0	16.8	24.0	29.0	25.0	17.5	0.8	400			
ECWF4245□L()	2.4	28.0	17.5	24.8	29.8	25.0	17.5	0.8				

* □ : Capacitance tolerance code
() : Suffix for lead crimped

Rating · Dimensions · Quantity

● Rated voltage : 630 V.DC, Capacitance tolerance : ± 3 %(J), ±5 %(J)

Part No.	Cap. (μ F)	Dimensions (mm)							Min. order Q'ty		
		L max.	T max.	H max.		F	S	ϕ d	Taping	Bulk	
				Straight	Crimped lead	Straight	Crimped lead		7.5 mm	Straight	Crimped lead
ECWF6103□L()	0.010	12.5	5.2	8.0	13.0	10.0	7.5	0.6	1200	500	500
ECWF6113□L()	0.011	12.5	5.4	8.2	13.2	10.0	7.5	0.6			
ECWF6123□L()	0.012	12.5	5.5	8.3	13.3	10.0	7.5	0.6			
ECWF6133□L()	0.013	12.5	5.6	8.5	13.5	10.0	7.5	0.6	1100		
ECWF6153□L()	0.015	12.5	5.9	8.7	13.7	10.0	7.5	0.6			
ECWF6163□L()	0.016	12.5	6.0	8.9	13.9	10.0	7.5	0.6			
ECWF6183□L()	0.018	12.5	6.2	9.1	14.1	10.0	7.5	0.6	1000		
ECWF6203□L()	0.020	12.5	6.5	9.3	14.3	10.0	7.5	0.6			
ECWF6223□L()	0.022	12.5	6.2	9.0	14.0	10.0	7.5	0.6			
ECWF6243□L()	0.024	12.5	6.4	9.2	14.2	10.0	7.5	0.6	900		
ECWF6273□L()	0.027	13.0	6.6	9.5	14.5	10.0	7.5	0.8			
ECWF6303□L()	0.030	13.0	6.9	9.7	14.7	10.0	7.5	0.8			
ECWF6333□L()	0.033	13.0	7.1	10.0	15.0	10.0	7.5	0.8	800		
ECWF6363□L()	0.036	13.0	7.3	10.2	15.2	10.0	7.5	0.8			
ECWF6393□L()	0.039	13.0	7.6	10.4	15.4	10.0	7.5	0.8			
ECWF6433□L()	0.043	13.0	7.9	10.7	15.7	10.0	7.5	0.8	500		
ECWF6473□L()	0.047	15.5	6.4	10.8	15.8	12.5	7.5	0.8			
ECWF6513□L()	0.051	15.5	6.6	11.0	16.0	12.5	7.5	0.8			
ECWF6563□L()	0.056	15.5	6.8	11.2	16.2	12.5	7.5	0.8	400		
ECWF6623□L()	0.062	15.5	7.1	11.5	16.5	12.5	7.5	0.8			
ECWF6683□L()	0.068	15.5	7.4	11.8	16.8	12.5	7.5	0.8			
ECWF6753□L()	0.075	15.5	7.7	12.1	17.1	12.5	7.5	0.8			
ECWF6823□L()	0.082	15.5	8.0	12.4	17.4	12.5	7.5	0.8			
ECWF6913□L()	0.091	15.5	8.3	12.7	17.7	12.5	7.5	0.8			
ECWF6104□L()	0.10	18.0	7.7	12.1	17.1	15.0	10.0	0.8	300		
ECWF6114□L()	0.11	18.0	8.0	12.4	17.4	15.0	10.0	0.8			
ECWF6124□L()	0.12	18.0	8.3	12.7	17.7	15.0	10.0	0.8			
ECWF6134□L()	0.13	18.0	8.5	13.0	18.0	15.0	10.0	0.8			
ECWF6154□L()	0.15	18.0	9.1	13.5	18.5	15.0	10.0	0.8			
ECWF6164□L()	0.16	18.0	9.3	13.8	18.8	15.0	10.0	0.8			
ECWF6184□L()	0.18	18.0	9.8	14.2	19.1	15.0	10.0	0.8	200		
ECWF6204□L()	0.20	18.0	10.3	14.7	19.7	15.0	10.0	0.8			
ECWF6224□L()	0.22	18.0	10.8	15.5	20.5	15.0	10.0	0.8			
ECWF6244□L()	0.24	18.0	11.2	15.9	20.9	15.0	10.0	0.8	300		
ECWF6274□L()	0.27	20.5	10.4	16.7	21.7	17.5	12.5	0.8			
ECWF6304□L()	0.30	20.5	10.9	17.2	22.2	17.5	12.5	0.8			
ECWF6334□L()	0.33	20.5	11.4	17.7	22.7	17.5	12.5	0.8	200		
ECWF6364□L()	0.36	20.5	11.9	18.5	23.5	17.5	12.5	0.8			
ECWF6394□L()	0.39	20.5	12.4	19.0	24.0	17.5	12.5	0.8			
ECWF6434□L()	0.43	20.5	13.0	19.5	24.5	17.5	12.5	0.8	-		
ECWF6474□L()	0.47	20.5	13.5	20.1	25.1	17.5	12.5	0.8			
ECWF6514□L()	0.51	28.0	11.1	17.3	22.3	25.0	17.5	0.8			
ECWF6564□L()	0.56	28.0	11.6	17.8	22.8	25.0	17.5	0.8			
ECWF6624□L()	0.62	28.0	12.1	18.7	23.7	25.0	17.5	0.8			
ECWF6684□L()	0.68	28.0	12.7	19.3	24.3	25.0	17.5	0.8			
ECWF6754□L()	0.75	28.0	13.3	19.9	24.9	25.0	17.5	0.8			
ECWF6824□L()	0.82	28.0	13.9	20.5	25.5	25.0	17.5	0.8			
ECWF6914□L()	0.91	28.0	14.6	21.2	26.2	25.0	17.5	0.8			
ECWF6105□L()	1.0	28.0	15.5	22.3	27.3	25.0	17.5	0.8			
ECWF6115□L()	1.1	28.0	16.3	23.0	28.0	25.0	17.5	0.8			
ECWF6125□L()	1.2	28.0	17.0	23.7	28.7	25.0	17.5	0.8			
ECWF6135□L()	1.3	28.0	17.6	24.4	29.4	25.0	17.5	0.8			

* □ : Capacitance tolerance code
() : Suffix for lead crimped

Metalized Polypropylene Film Capacitor

Series : **ECWF(A)**

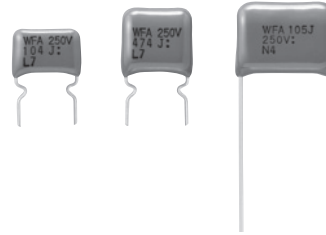

Non-inductive construction using metallized polypropylene film with flame retardant epoxy resin coating.

Features

- Small size
- Excellent frequency characteristics
- Low loss
- Low Hum Sound Noise
- Flame retardant epoxy resin coating
- 85 degree C , 85 %RH , 500 V.DC , 500 hours (630 V.DC)
- RoHS directive compliant

Recommended applications

- 250 V.DC, 630 V.DC : High frequency and high current circuit
- 450 V.DC : Active filter circuit

Explanation of part number

- 250 V.DC, 450 V.DC (Bulk)

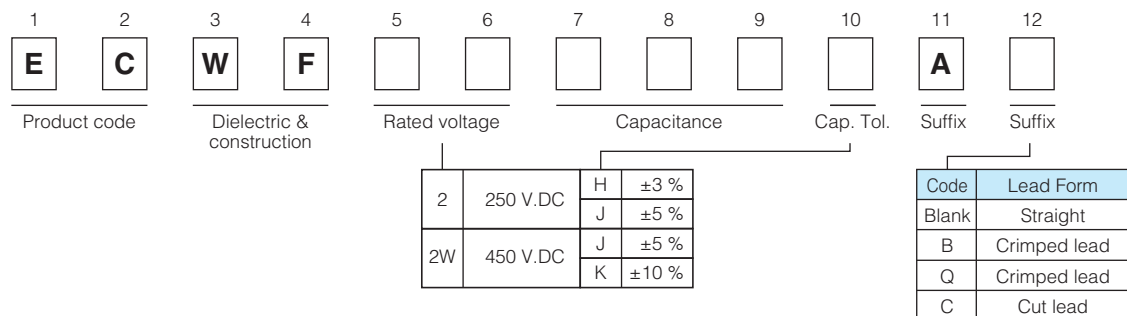

- 250 V.DC, 450 V.DC (Odd size taping)

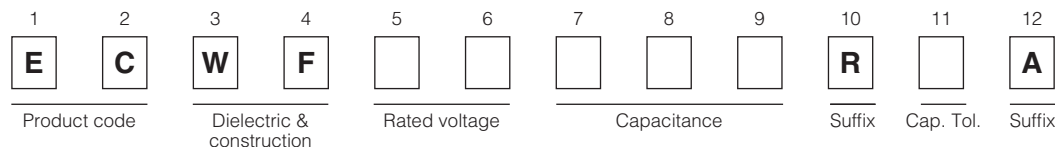

- 630 V.DC (Bulk, Odd size taping)

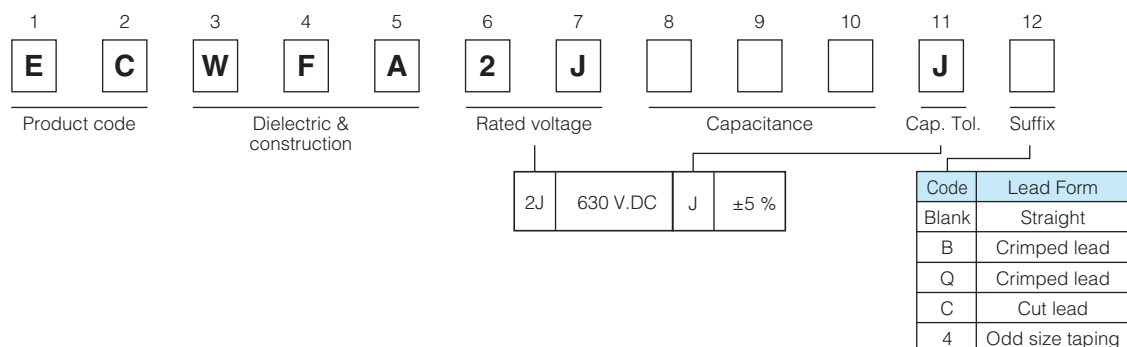

Specifications

Category temp. range (Including temperature-rise on unit surface)	- 40 °C to +105 °C	
Rated voltage	250 V.DC	
	450 V.DC (Derating of rated voltage by 1.25%/°C at more than 85 °C) Peak to peak voltage applied on the capacitor should be less than 240 Vp-p, and zero to peak voltage should be less than 450 Vo-p.	
	630 V.DC (Derating of rated voltage by 1.0%/°C at more than 85 °C)	
Capacitance range	250 V.DC	0.1 μF to 6.8 μF
	450 V.DC	0.1 μF to 4.7 μF
	630 V.DC	0.1 μF to 2.2 μF
Capacitance tolerance	250 V.DC	±3 % (H), ±5 % (J)
	450 V.DC	±5 % (J), ±10 % (K)
	630 V.DC	±5 % (J)
Dissipation factor (tan δ)	tan δ ≤ 0.1 % (20 °C, 1 kHz)	
Withstand voltage	Between terminals : Rated volt. (V.DC) × 150 %, 60 s	
Insulation resistance (IR)	250 V.DC	C ≤ 0.33 μF : IR ≥ 9000 MΩ C > 0.33 μF : IR ≥ 3000 MΩ · μF (20 °C, 100 V.DC, 60 s)
	450 V.DC	C ≤ 0.33 μF : IR ≥ 30000 MΩ C > 0.33 μF : IR ≥ 10000 MΩ · μF (20 °C, 100 V.DC, 60 s)
	630 V.DC	C ≤ 0.33 μF : IR ≥ 9000 MΩ C > 0.33 μF : IR ≥ 3000 MΩ · μF (20 °C, 500 V.DC, 60 s)

* In case of applying voltage in alternating current (50 Hz or 60 Hz sine wave) to a capacitor with DC rated voltage, please refer to the page of "Permissible voltage (R.M.S) in alternating current corresponding to DC rated voltage".

Dimensions

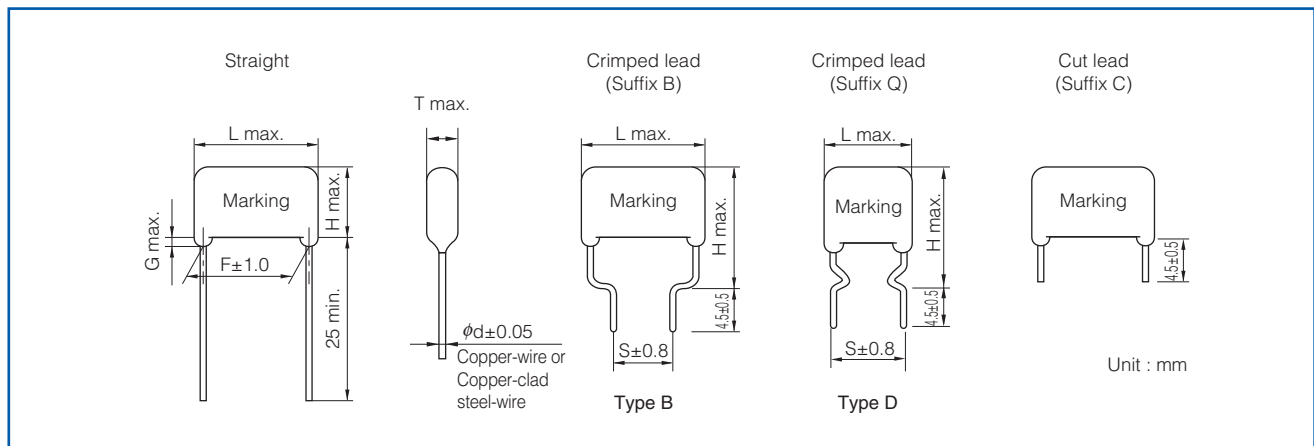

Packaging specifications for bulk package

- Packing quantity : 100 pcs./bag

Taping specifications for automatic insertion

● Taping style

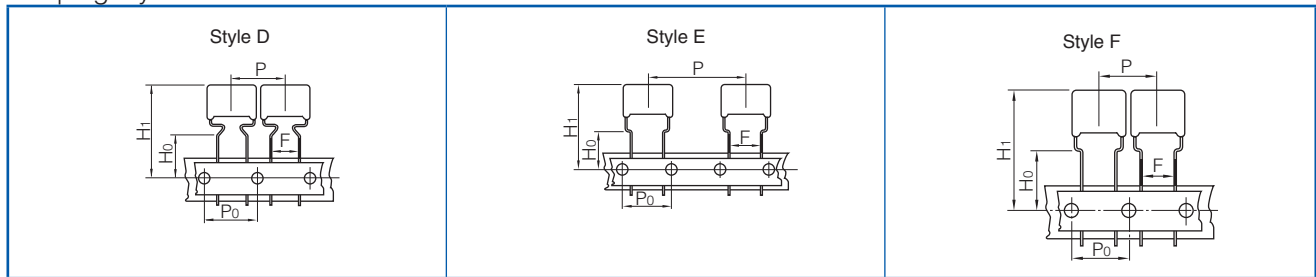

* Refer to the page of taping specifications.

● Packaging specifications

Series	Rated voltage (V.DC)	Capacitance range (μF)	Taping style								Packing	suffix
			AD	AS	B	C	D	E	F			
ECWF(A)	250	0.10 to 0.47					○				Ammo	R() A
		0.56 to 3.9						○				
	450	0.10 to 0.47							○			
		0.56 to 2.2							○			
	630	0.10 to 0.68							○			
									○			

● Lead spacing

Style	Lead spacing
D	7.5 mm
E	7.5 mm
F	7.5 mm

Rating · Dimensions · Quantity

● Rated voltage : 250 V.DC, Capacitance tolerance : ± 3 % (H), ± 5 % (J)

Part No.	Cap. (μF)	Dimensions (mm)										Min. order Q'ty	
		L max.	T max.	H max.			F	S		G max.	φd	Taping 7.5 mm	Bulk Straight · Crimped lead
				Straight	Crimped lead (Suffix B)	Crimped lead (Suffix Q)		Crimped lead (Suffix B)	Crimped lead (Suffix Q)				
ECWF2104□A()	0.10	13.0	5.0	-	14.1	14.1	-	7.5	10.0	-	0.6	1300	500
ECWF2124□A()	0.12	13.0	5.3	-	14.4	14.4	-	7.5	10.0	-	0.6	1200	
ECWF2154□A()	0.15	13.0	5.6	-	14.7	14.7	-	7.5	10.0	-	0.6	1100	
ECWF2184□A()	0.18	13.0	5.9	-	15.1	15.1	-	7.5	10.0	-	0.6	1000	
ECWF2224□A()	0.22	13.0	6.3	-	15.4	15.4	-	7.5	10.0	-	0.6	900	
ECWF2274□A()	0.27	13.0	6.8	-	15.9	15.9	-	7.5	10.0	-	0.6	800	
ECWF2334□A()	0.33	13.0	7.3	-	16.4	16.4	-	7.5	10.0	-	0.6	700	
ECWF2394□A()	0.39	13.0	7.8	-	16.9	16.9	-	7.5	10.0	-	0.6	600	
ECWF2474□A()	0.47	13.0	8.4	-	17.6	17.6	-	7.5	10.0	-	0.6	500	
ECWF2564□A()	0.56	18.1	6.9	-	16.4	18.4	-	7.5	15.0	-	0.8	400	
ECWF2684□A()	0.68	18.1	7.4	-	17.0	19.0	-	7.5	15.0	-	0.8	300	
ECWF2824□A()	0.82	18.1	8.0	-	17.6	19.6	-	7.5	15.0	-	0.8	200	
ECWF2105□A()	1.0	18.1	8.5	13.3	18.3	20.3	15.0	7.5	15.0	1.5	0.8	100	
ECWF2125□A()	1.2	18.8	9.5	14.6	19.6	21.6	15.0	7.5	15.0	1.5	0.8	50	
ECWF2155□A()	1.5	18.8	10.5	15.6	20.6	22.6	15.0	7.5	15.0	1.5	0.8	20	
ECWF2185□A()	1.8	18.8	11.4	16.5	21.5	23.5	15.0	7.5	15.0	1.5	0.8	10	
ECWF2225□A()	2.2	18.8	12.6	17.6	22.6	24.6	15.0	7.5	15.0	1.5	0.8	5	
ECWF2275□A()	2.7	23.8	11.4	17.2	22.2	24.2	20.0	12.5	20.0	1.5	0.8	300	
ECWF2335□A()	3.3	23.8	12.5	18.3	23.3	25.3	20.0	12.5	20.0	1.5	0.8	200	
ECWF2395□A()	3.9	23.8	13.5	19.3	24.3	26.3	20.0	12.5	20.0	1.5	0.8	100	
ECWF2475□A()	4.7	23.8	14.8	20.6	25.6	27.6	20.0	12.5	20.0	1.5	0.8	50	
ECWF2565□A()	5.6	23.8	16.2	21.9	26.9	28.9	20.0	12.5	20.0	1.5	0.8	20	
ECWF2685□A()	6.8	23.8	17.8	23.5	28.5	30.5	20.0	12.5	20.0	1.5	0.8	10	

* □ : Capacitance tolerance code
() : Suffix for lead crimped

Rating · Dimensions · Quantity

● Rated voltage : 450 V.DC, Capacitance tolerance : $\pm 5\%$ (J), $\pm 10\%$ (K)

Part No.	Cap. (μ F)	Dimensions (mm)										Min. order Q'ty	
		L max.	T max.	H max.			F	S		G max.	ϕ d	Taping	Bulk
				Straight	Crimped lead (Suffix B)	Crimped lead (Suffix Q)		Crimped lead (Suffix B)	Crimped lead (Suffix Q)			7.5 mm	Straight · Crimped lead
ECWF2W104□A()	0.10	13.0	5.1	-	14.3	14.3	-	7.5	10.0	1.5	0.6	1200	500
ECWF2W124□A()	0.12	13.0	5.4	-	14.5	14.5	-	7.5	10.0	1.5	0.6	1200	
ECWF2W154□A()	0.15	13.0	5.7	-	14.9	14.9	-	7.5	10.0	1.5	0.6	1000	
ECWF2W184□A()	0.18	13.0	6.1	-	15.2	15.2	-	7.5	10.0	1.5	0.6	1000	
ECWF2W224□A()	0.22	13.0	6.5	-	15.6	15.6	-	7.5	10.0	1.5	0.6	800	
ECWF2W274□A()	0.27	13.0	7.0	-	16.1	16.1	-	7.5	10.0	1.5	0.6	800	
ECWF2W334□A()	0.33	13.0	7.6	-	16.7	16.7	-	7.5	10.0	1.5	0.6	800	
ECWF2W394□A()	0.39	13.0	8.1	-	17.2	17.2	-	7.5	10.0	1.5	0.6	600	
ECWF2W474□A()	0.47	13.0	8.7	-	17.9	17.9	-	7.5	10.0	1.5	0.6	600	
ECWF2W564□A()	0.56	18.1	7.0	11.5	16.5	18.5	15.0	7.5	15.0	1.5	0.8	400	
ECWF2W684□A()	0.68	18.1	7.5	12.1	17.1	19.1	15.0	7.5	15.0	1.5	0.8	400	
ECWF2W824□A()	0.82	18.1	8.2	12.7	17.7	19.7	15.0	7.5	15.0	1.5	0.8	300	
ECWF2W105□A()	1.0	18.1	9.3	12.6	17.6	19.6	15.0	7.5	15.0	1.5	0.8	300	
ECWF2W125□A()	1.2	18.8	9.7	14.7	19.7	21.7	15.0	7.5	15.0	1.5	0.8	200	
ECWF2W155□A()	1.5	18.8	10.7	15.8	20.8	22.8	15.0	7.5	15.0	1.5	0.8	200	
ECWF2W185□A()	1.8	18.8	11.6	16.7	21.7	23.7	15.0	7.5	15.0	1.5	0.8	-	
ECWF2W225□A()	2.2	18.8	12.8	17.9	22.9	24.9	15.0	7.5	15.0	1.5	0.8	-	
ECWF2W275□A()	2.7	26.3	10.6	16.5	21.5	23.5	22.5	15.0	22.5	1.5	0.8	-	
ECWF2W335□A()	3.3	26.3	11.7	17.5	22.5	24.5	22.5	15.0	22.5	1.5	0.8	-	
ECWF2W395□A()	3.9	26.3	12.6	18.4	23.4	25.4	22.5	15.0	22.5	1.5	0.8	-	
ECWF2W475□A()	4.7	26.3	13.8	19.6	24.6	26.6	22.5	15.0	22.5	1.5	0.8	-	

* □ : Capacitance tolerance code
() : Suffix for lead crimped

● Rated voltage : 630 V.DC, Capacitance tolerance : $\pm 5\%$ (J)

Part No.	Cap. (μ F)	Dimensions (mm)										Min. order Q'ty		
		L max.	T max.	H max.			F	S		G max.	ϕ d	Taping	Bulk	
				Straight	Crimped lead (Suffix B)	Crimped lead (Suffix Q)		Crimped lead (Suffix B)	Crimped lead (Suffix Q)			7.5 mm	Straight	Crimped lead
ECWFA2J104J()	0.10	18.2	5.2	10.4	15.4	15.4	15.0	7.5	15.0	1.5	0.6	600	1000	1000
ECWFA2J124J()	0.12	18.2	5.5	10.8	15.8	15.8	15.0	7.5	15.0	1.5	0.6	500		
ECWFA2J154J()	0.15	18.2	6.0	11.2	16.2	16.2	15.0	7.5	15.0	1.5	0.6	500		
ECWFA2J184J()	0.18	18.2	6.5	11.7	16.7	16.7	15.0	7.5	15.0	1.5	0.6	400		
ECWFA2J224J()	0.22	18.2	7.1	12.3	17.3	17.3	15.0	7.5	15.0	1.5	0.6	400		
ECWFA2J274J()	0.27	18.2	7.8	12.9	17.9	17.9	15.0	7.5	15.0	1.5	0.6	300		
ECWFA2J334J()	0.33	18.2	8.5	13.6	18.6	18.6	15.0	7.5	15.0	1.5	0.6	300		
ECWFA2J394J()	0.39	18.2	9.2	14.3	19.3	19.3	15.0	7.5	15.0	1.5	0.6	200		
ECWFA2J474J()	0.47	18.2	10.0	15.1	20.1	20.1	15.0	7.5	15.0	1.5	0.6	200		
ECWFA2J564J()	0.56	18.2	10.9	16.0	21.0	21.0	15.0	7.5	15.0	1.5	0.6	800		
ECWFA2J684J()	0.68	18.2	12.0	17.1	22.1	22.1	15.0	7.5	15.0	1.5	0.6	800		
ECWFA2J824J()	0.82	26.0	10.1	15.3	20.3	22.3	22.5	15.0	22.5	1.5	0.8	-	600	600
ECWFA2J105J()	1.0	26.0	11.1	16.2	21.2	23.2	22.5	15.0	22.5	1.5	0.8	-		
ECWFA2J125J()	1.2	26.0	12.1	17.2	22.2	24.2	22.5	15.0	22.5	1.5	0.8	-		
ECWFA2J155J()	1.5	26.0	13.5	18.6	23.6	25.6	22.5	15.0	22.5	1.5	0.8	-		
ECWFA2J185J()	1.8	26.0	14.8	19.8	24.8	26.8	22.5	15.0	22.5	1.5	0.8	500		
ECWFA2J225J()	2.2	26.0	16.3	21.4	26.4	28.4	22.5	15.0	22.5	1.5	0.8	400		

* () : Suffix for lead crimped

UPGRADE

Metallized Polypropylene Film Capacitor

ECWFD series

Non-inductive construction using metallized polypropylene film with flame retardant epoxy resin coating.



Features

- Small size
- Excellent frequency characteristics
- Low loss
- Flame-retardant epoxy resin coating
- Low hum sound noise
- RoHS compliant

Recommended applications

- Active filter circuit
- High frequency circuit

Explanation of part number

■ Standard product

1	2	3	4	5	6	7	8	9	10	11	12																										
E	C	W	F	D																																	
Product code		Dielectric & construction			Rated voltage		Capacitance			Cap. Tol.	Suffix																										
					<table border="1"> <thead> <tr> <th>Code</th><th>R. voltage</th></tr> </thead> <tbody> <tr> <td>2W</td><td>450 V.DC</td></tr> <tr> <td>2J</td><td>630 V.DC</td></tr> </tbody> </table>		Code	R. voltage	2W	450 V.DC	2J	630 V.DC	<table border="1"> <thead> <tr> <th>Code</th><th>Cap. Tol.</th></tr> </thead> <tbody> <tr> <td>J</td><td>±5 %</td></tr> <tr> <td>K</td><td>±10 %</td></tr> </tbody> </table>			Code	Cap. Tol.	J	±5 %	K	±10 %	<table border="1"> <thead> <tr> <th>Code</th><th>Lead form</th></tr> </thead> <tbody> <tr> <td>Blank</td><td>Straight</td></tr> <tr> <td>B</td><td>Crimped lead</td></tr> <tr> <td>Q</td><td>Crimped lead</td></tr> <tr> <td>C</td><td>Cut lead</td></tr> <tr> <td>3</td><td>Crimped taping (Ammo)</td></tr> <tr> <td>4</td><td>Odd size taping</td></tr> </tbody> </table>		Code	Lead form	Blank	Straight	B	Crimped lead	Q	Crimped lead	C	Cut lead	3	Crimped taping (Ammo)	4	Odd size taping
Code	R. voltage																																				
2W	450 V.DC																																				
2J	630 V.DC																																				
Code	Cap. Tol.																																				
J	±5 %																																				
K	±10 %																																				
Code	Lead form																																				
Blank	Straight																																				
B	Crimped lead																																				
Q	Crimped lead																																				
C	Cut lead																																				
3	Crimped taping (Ammo)																																				
4	Odd size taping																																				

■ Short lead space product 450 V.DC (0.47 μF, 0.68 μF, 1.0 μF), 630 V.DC (1.0 μF)

1	2	3	4	5	6	7	8	9	10	11	12																										
E	C	W	F	D																																	
Product code		Dielectric & construction			Rated voltage		Capacitance			Suffix1	Suffix2																										
					<table border="1"> <thead> <tr> <th>Code</th><th>R. voltage</th></tr> </thead> <tbody> <tr> <td>2W</td><td>450 V.DC</td></tr> <tr> <td>2J</td><td>630 V.DC</td></tr> </tbody> </table>		Code	R. voltage	2W	450 V.DC	2J	630 V.DC	<table border="1"> <thead> <tr> <th>Code</th><th>Cap. Tol.</th></tr> </thead> <tbody> <tr> <td>P</td><td>±5 % (J)</td></tr> <tr> <td>Q</td><td>±10 % (K)</td></tr> </tbody> </table>			Code	Cap. Tol.	P	±5 % (J)	Q	±10 % (K)	<table border="1"> <thead> <tr> <th>Code</th><th>Lead form</th></tr> </thead> <tbody> <tr> <td>1</td><td>Straight</td></tr> <tr> <td>B</td><td>Crimped lead</td></tr> <tr> <td>Q</td><td>Crimped lead</td></tr> <tr> <td>C</td><td>Cut lead</td></tr> <tr> <td>3</td><td>Crimped taping (Ammo)</td></tr> <tr> <td>4</td><td>Odd size taping</td></tr> </tbody> </table>		Code	Lead form	1	Straight	B	Crimped lead	Q	Crimped lead	C	Cut lead	3	Crimped taping (Ammo)	4	Odd size taping
Code	R. voltage																																				
2W	450 V.DC																																				
2J	630 V.DC																																				
Code	Cap. Tol.																																				
P	±5 % (J)																																				
Q	±10 % (K)																																				
Code	Lead form																																				
1	Straight																																				
B	Crimped lead																																				
Q	Crimped lead																																				
C	Cut lead																																				
3	Crimped taping (Ammo)																																				
4	Odd size taping																																				

Specifications

Category temp. range (Including temperature-rise on unit surface)	450 V.DC	-40 °C to +110 °C
	630 V.DC	-40 °C to +105 °C
Rated voltage	450 V.DC	Peak to peak voltage applied on the capacitor should be less than 240 Vp-p, and zero to peak voltage should be less than 450 Vo-p. (Derating of rated voltage by 0.62 %/°C at more than 85 °C)
	630 V.DC	Peak to peak voltage applied on the capacitor should be less than 400 Vp-p, and zero to peak voltage should be less than 630 Vo-p. (Derating of rated voltage by 1.0%/°C at more than 85 °C)
Capacitance range	450 V.DC	0.1 μF to 4.7 μF
	630 V.DC	0.01 μF to 4.7 μF
Capacitance tolerance	±5% (J), ±10 % (K)	
Dissipation factor (tan δ)	tan δ ≤ 0.1 % (20 °C, 1 kHz)	
Withstand voltage	Between terminals : Rated voltage (V.DC)×150 % 60 s	
Insulation resistance (IR)	450 V.DC	C ≤ 0.33 μF : IR ≥ 30,000 MΩ C > 0.33 μF : IR ≥ 10,000 MΩ·μF (20 °C, 100 V.DC, 60 s)
	630 V.DC	C ≤ 0.33 μF : IR ≥ 9,000 MΩ C > 0.33 μF : IR ≥ 3,000 MΩ·μF (20 °C, 500 V.DC, 60 s)

*: In case of applying voltage in alternating current (50 Hz or 60 Hz sine wave) to a capacitor with DC rated voltage, please refer to the page of "Permissible voltage (R.M.S) in alternating current corresponding to DC rated voltage".

Dimensions

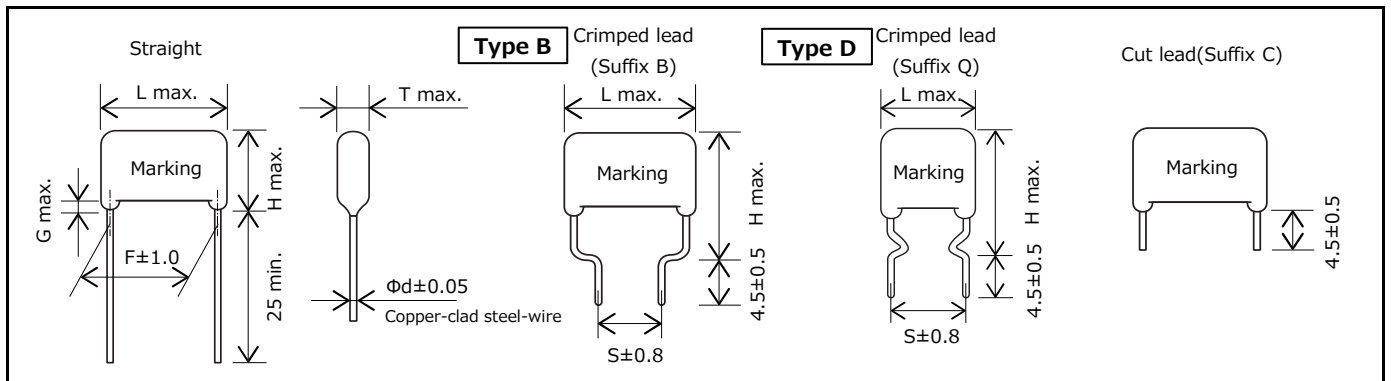

Packaging specifications for bulk package

- Packing quantity : 100 pcs./bag

Taping specifications for automatic insertion

- Taping style

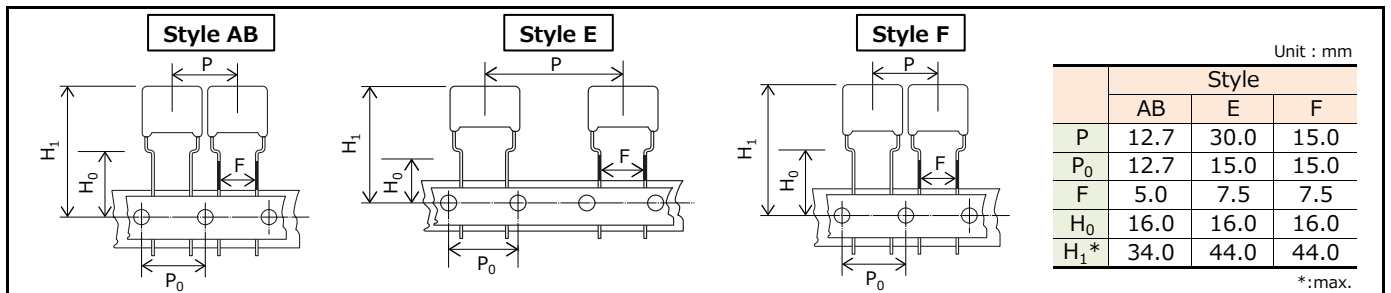

*: H1 dimension is based on insertion machine "Panaset RH series" made by Panasonic. Consult with Panasonic technical staff when using other insertion machines.

- Packaging specifications

Series	Rated volt. (V.DC)	Capacitance range (μF)	Taping style			Packing	suffix
			AB	E	F		
ECWFD	450	0.10 to 0.39	○			Crimped taping	3
		0.47, 0.68, 1.0	○				P3/Q3
		0.10 to 0.39			○		4
	630	0.47 to 2.2		○		Odd size taping	P4/Q4
		0.047 to 0.22			○		4
		0.27 to 0.82		○			4
		1		○		P4/Q4	

- Lead spacing

Style	Lead spacing
AB	5.0
E	7.5
F	7.5

Unit : mm

See the column "Rating · Dimensions · Quantity" for packaging quantity

Rating · Dimensions · Quantity

■ Rated voltage : 450 V.DC, Capacitance tolerance : ±5 %(J), ± 10 %(K)

Part No.	Cap. (μF)	Dimensions (mm)										Min. order Q'ty (PCS)			
		L max.	T max.	H max.			F	S		G max.	Φd	Taping		Bulk	
				Straight	Crimped lead (Suffix B)	Crimped lead (Suffix Q)		Crimped lead (Suffix B)	Crimped lead (Suffix Q)			Standard 5.0 mm	Odd size 7.5 mm	Straight	Crimped lead
ECWFD2W104□()	0.10	12.6	4.5	-	13.9	13.9	-	7.5	10.0	-	0.6	1500	1400	-	
ECWFD2W124□()	0.12	12.6	4.6		14.0	14.0		7.5	10.0		0.6				
ECWFD2W154□()	0.15	12.6	4.6		14.1	14.1		7.5	10.0		0.6	1400	1300	-	
ECWFD2W184□()	0.18	12.6	4.8		14.3	14.3		7.5	10.0		0.6				
ECWFD2W224□()	0.22	12.6	5.0		14.6	14.6		7.5	10.0		0.6	1300	1200	-	
ECWFD2W274□()	0.27	12.6	5.3		15.0	15.0		7.5	10.0		0.6				
ECWFD2W334□()	0.33	12.6	5.6		15.4	15.4		7.5	10.0		0.6	1200	1100		
ECWFD2W394□()	0.39	12.6	6.0		15.7	15.7		7.5	10.0		0.6	1100	1000		
ECWFD2W474P()	0.47	12.6	6.5	11.2	16.2	16.2	10.0	7.5	10.0	1.5	0.6	1000	900		
ECWFD2W474Q()															
ECWFD2W474□()	0.47	17.5	5.8	9.0	14.0	16.0	15.0	7.5	15.0	1.5	0.8	-	500		
ECWFD2W564□()	0.56	17.5	6.2	9.4	14.4	16.4	15.0	7.5	15.0	1.5	0.8				
ECWFD2W684P()	0.68	12.6	7.7	12.4	17.4	17.4	10.0	7.5	10.0	1.5	0.6	800	700		
ECWFD2W684Q()															
ECWFD2W684□()	0.68	17.5	6.7	9.9	14.9	16.9	15.0	7.5	15.0	1.5	0.8	-	400		
ECWFD2W824□()	0.82	17.5	7.2	10.4	15.4	17.4	15.0	7.5	15.0	1.5	0.8				
ECWFD2W105P()	1.0	12.6	9.2	13.9	18.9	18.9	10.0	7.5	10.0	1.5	0.6	700	600		
ECWFD2W105Q()															
ECWFD2W105□()	1.0	17.5	7.8	11.0	16.0	18.0	15.0	7.5	15.0	1.5	0.8		400		
ECWFD2W125□()	1.2	17.5	8.5	11.6	16.6	18.6	15.0	7.5	15.0	1.5	0.8				
ECWFD2W155□()	1.5	17.5	9.3	12.5	17.5	19.5	15.0	7.5	15.0	1.5	0.8		300		
ECWFD2W185□()	1.8	17.5	10.1	13.3	18.3	20.3	15.0	7.5	15.0	1.5	0.8				
ECWFD2W225□()	2.2	17.5	11.1	14.3	19.3	21.3	15.0	7.5	15.0	1.5	0.8	-	200		
ECWFD2W275□()	2.7	25.3	9.0	13.7	18.7	20.7	22.5	15.0	22.5	1.5	0.8				
ECWFD2W335□()	3.3	25.3	9.8	14.6	19.6	21.6	22.5	15.0	22.5	1.5	0.8				
ECWFD2W395□()	3.9	25.3	10.7	15.4	20.4	22.4	22.5	15.0	22.5	1.5	0.8			800	
ECWFD2W475□()	4.7	25.3	11.7	16.4	21.4	23.4	22.5	15.0	22.5	1.5	0.8			600	600

* □ : Capacitance tolerance code
 * () : Suffix for lead crimped

Note) Part number marked with bold is short lead space product.

Rating · Dimensions · Quantity

■ Rated voltage : 630 V.DC, Capacitance tolerance : ±5 %(J), ± 10 %(K)

Part No.	Cap. (μF)	Dimensions (mm)										Min. order Q'ty (PCS)			
		L max.	T max.	H max.			F	S		G max.	Φd	Taping	Bulk		
				Straight	Crimped lead (Suffix B)	Crimped lead (Suffix Q)		Crimped lead (Suffix B)	Crimped lead (Suffix Q)			Odd size 7.5 mm	Straight	Crimped lead	
NEW ECWFD2J103□()	0.01	12.6	4.9	-	8.0	8.0	-	7.5	10.0	-	0.6	-	-	1000	
NEW ECWFD2J123□()	0.012	12.6	5.2	-	8.2	8.2	-	7.5	10.0	-	0.6	-	-		
NEW ECWFD2J153□()	0.015	12.6	5.6	-	8.6	8.6	-	7.5	10.0	-	0.6	-	-		
NEW ECWFD2J183□()	0.018	12.6	5.9	-	9.0	9.0	-	7.5	10.0	-	0.6	-	-		
NEW ECWFD2J223□()	0.022	12.6	6.4	-	9.4	9.4	-	7.5	10.0	-	0.6	-	-		
NEW ECWFD2J273□()	0.027	12.6	6.9	-	9.9	9.9	-	7.5	10.0	-	0.6	-	-		
NEW ECWFD2J333□()	0.033	12.6	7.5	-	10.5	10.5	-	7.5	10.0	-	0.6	-	-		
NEW ECWFD2J393□()	0.039	12.6	8.0	-	11.0	11.0	-	7.5	10.0	-	0.6	-	-		
ECWFD2J473□()	0.047	12.6	4.4	-	12.8	12.8	-	7.5	10.0	-	0.6	1300	-	1000	
ECWFD2J563□()	0.056	12.6	4.7	-	13.1	13.1	-	7.5	10.0	-	0.6	1200	-		
ECWFD2J683□()	0.068	12.6	5.0	-	13.4	13.4	-	7.5	10.0	-	0.6	-	-		
ECWFD2J823□()	0.082	12.6	5.4	-	13.7	13.7	-	7.5	10.0	-	0.6	1000	-		
ECWFD2J104□()	0.10	12.6	5.8	-	14.2	14.2	-	7.5	10.0	-	0.6	900	-		
ECWFD2J124□()	0.12	12.6	6.2	-	14.6	14.6	-	7.5	10.0	-	0.6	700	-		
ECWFD2J154□()	0.15	12.6	6.8	-	15.2	15.2	-	7.5	10.0	-	0.6	-	-		
ECWFD2J184□()	0.18	12.6	7.4	-	15.7	15.7	-	7.5	10.0	-	0.6	-	-		
ECWFD2J224□()	0.22	12.6	8.1	-	16.4	16.4	-	7.5	10.0	-	0.6	-	-		
ECWFD2J274□()	0.27	17.8	6.0	11.0	16.0	18.0	15.0	7.5	15.0	1.5	0.8	500	-		
ECWFD2J334□()	0.33	17.8	6.6	11.5	16.5	18.5	15.0	7.5	15.0	1.5	0.8	-	-		
ECWFD2J394□()	0.39	17.8	7.1	12.0	17.0	19.0	15.0	7.5	15.0	1.5	0.8	400	-		
ECWFD2J474□()	0.47	17.8	7.8	12.7	17.7	19.7	15.0	7.5	15.0	1.5	0.8	-	-		
ECWFD2J564□()	0.56	17.8	8.4	13.3	18.3	20.3	15.0	7.5	15.0	1.5	0.8	300	1000		
ECWFD2J684□()	0.68	17.8	9.3	14.2	19.2	21.2	15.0	7.5	15.0	1.5	0.8	-	-		
ECWFD2J824□()	0.82	17.8	10.2	15.1	20.1	22.1	15.0	7.5	15.0	1.5	0.8	-	-		
ECWFD2J105P()	1.0	17.8	11.2	16.1	21.1	23.1	15.0	7.5	15.0	1.5	0.8	200	-	-	
ECWFD2J105Q()															
ECWFD2J105□()	1.0	25.3	8.4	13.5	18.5	20.5	22.5	15.0	22.5	1.5	0.8	-	-	800	
ECWFD2J125□()	1.2	25.3	9.2	14.3	19.3	21.3	22.5	15.0	22.5	1.5	0.8	-	-		
ECWFD2J155□()	1.5	25.3	10.3	15.5	20.5	22.5	22.5	15.0	22.5	1.5	0.8	-	-		
ECWFD2J185□()	1.8	25.3	11.2	16.5	21.5	23.5	22.5	15.0	22.5	1.5	0.8	-	-		
ECWFD2J225□()	2.2	25.3	12.4	17.7	22.7	24.7	22.5	15.0	22.5	1.5	0.8	-	600		800
ECWFD2J275□()	2.7	25.3	13.8	19.2	24.2	26.2	22.5	15.0	22.5	1.5	0.8	-	500		700
ECWFD2J335□()	3.3	25.3	15.3	20.7	25.7	27.7	22.5	15.0	22.5	1.5	0.8	-	400		600
ECWFD2J395□()	3.9	25.3	16.6	22.1	27.1	29.1	22.5	15.0	22.5	1.5	0.8	-	-		500
ECWFD2J475□()	4.7	25.3	18.3	23.9	28.9	30.9	22.5	15.0	22.5	1.5	0.8	-	300		400

*□ : Capacitance tolerance code
 *() : Suffix for lead crimped

Note) Part number marked with bold is short lead space product.

UPGRADE

Metallized Polypropylene Film Capacitor

ECWFE series

Non-inductive construction using metallized polypropylene film with flame retardant plastic case.



Features

- Small size
- Excellent frequency characteristics
- Low loss
- Flame retardant plastic case and non-combustible resin
- Low hum sound noise
- RoHS compliant

Recommended applications

- Active filter circuit
- High frequency circuit

Explanation of part number

■ Standard

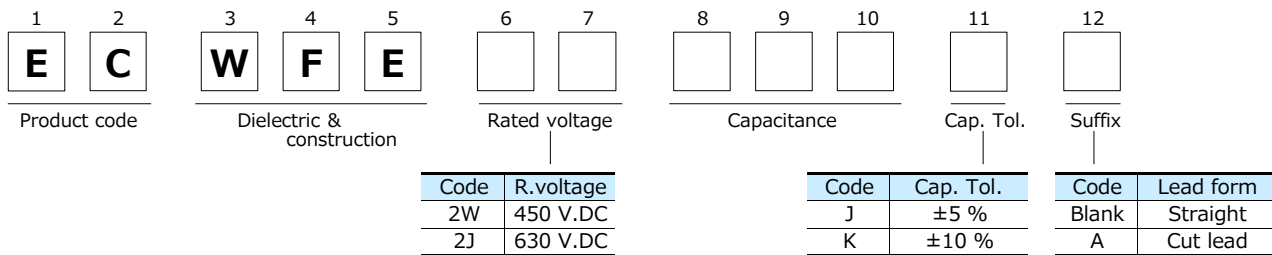

■ Special lead space product

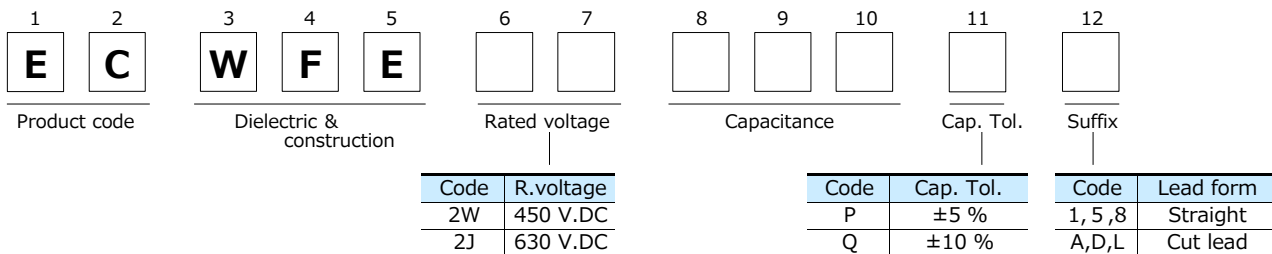

Specifications

Category temp. range (Including temperature-rise on unit surface)	-40 °C to +105 °C	
Rated voltage	450 V.DC	Peak to peak voltage applied on the capacitor should be less than 240 Vp-p, and zero to peak voltage should be less than 450 Vo-p. (Derating of rated voltage by 1.25 %/°C at more than 85 °C)
	630 V.DC	Peak to peak voltage applied on the capacitor should be less than 400 Vp-p, and zero to peak voltage should be less than 630 Vo-p. (Derating of rated voltage by 1.0%/°C at more than 85 °C)
Capacitance range	450 V.DC	0.1 μF to 4.7 μF
	630 V.DC	0.1 μF to 2.2 μF
Capacitance tolerance	±5% (J), ±10 % (K)	
Dissipation factor (tan δ)	tan δ ≤ 0.1 % (20 °C, 1 kHz)	
Withstand voltage	Between terminals : Rated voltage (V.DC)×150 % 60 s	
Insulation resistance (IR)	450 V.DC	C ≤ 0.33 μF : IR ≥ 30,000 MΩ C > 0.33 μF : IR ≥ 10,000 MΩ·μF (20 °C, 100 V.DC, 60 s)
	630 V.DC	C ≤ 0.33 μF : IR ≥ 9,000 MΩ C > 0.33 μF : IR ≥ 3,000 MΩ·μF (20 °C, 500 V.DC, 60 s)

* In case of applying voltage in alternating current (50 Hz or 60 Hz sine wave) to a capacitor with DC rated voltage, please refer to the page of "Permissible voltage (R.M.S) in alternating current corresponding to DC rated voltage".

Dimensions

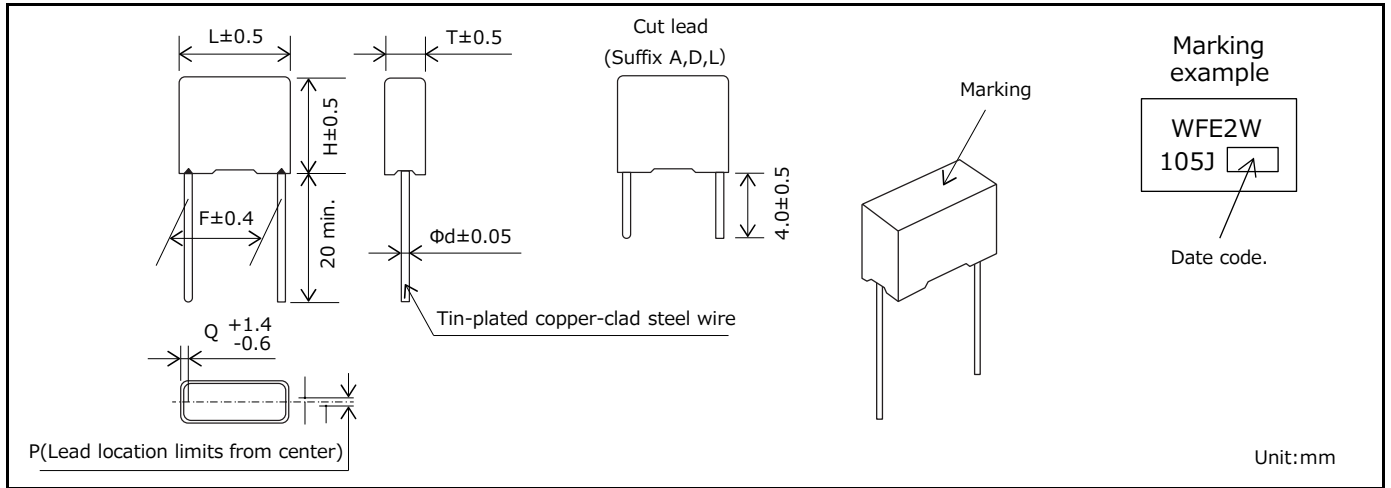

Rating · Dimensions · Quantity

■ Rated voltage : 450 V.DC, Capacitance tolerance : ±5 % (J), ± 10 % (K)

Part No.	Cap. (μF)	Dimensions (mm)							Min. order Q'ty (PCS)	
		L	T	H	F	Φd	P	Q	Straight	Cut lead
ECWFE2W104□()	0.10	13.0	5.0	10.5	10.0	0.6	0±0.8	1.5	1000	1000
NEW ECWFE2W104P()	0.10	17.5	5.0	10.5	15.0	0.6	0±0.8	1.25		
NEW ECWFE2W104Q()										
ECWFE2W154□()	0.15	13.0	5.0	10.5	10.0	0.6	0±0.8	1.5		
NEW ECWFE2W154P()	0.15	17.5	5.0	10.5	15.0	0.6	0±0.8	1.25		
NEW ECWFE2W154Q()										
ECWFE2W224□()	0.22	13.0	6.0	12.0	10.0	0.6	0±0.8	1.5		
NEW ECWFE2W224P()	0.22	17.5	5.0	10.5	15.0	0.6	0±0.8	1.25		
NEW ECWFE2W224Q()										
ECWFE2W334□()	0.33	13.0	6.0	12.0	10.0	0.6	0±0.8	1.5		
NEW ECWFE2W334P()	0.33	17.5	5.0	10.5	15.0	0.6	0±0.8	1.25		
NEW ECWFE2W334Q()										
NEW ECWFE2W474P()	0.47	13.0	7.0	12.5	10.0	0.6	0±0.8	1.5		
NEW ECWFE2W474Q()										
ECWFE2W474□()	0.47	17.5	6.0	11.5	15.0	0.8	0±0.8	1.3		
ECWFE2W684□()	0.68	17.5	7.0	12.5	15.0	0.8	0±0.8	1.3		
ECWFE2W105□()	1.0	17.5	7.0	12.5	15.0	0.8	0±0.8	1.3		
ECWFE2W155□()	1.5	17.5	10.0	15.5	15.0	0.8	0±0.8	1.3	600	
NEW ECWFE2W155P()	1.5	31.0	9.0	19.0	27.5	0.8	0±0.8	1.75	400	300
NEW ECWFE2W155Q()										
ECWFE2W225□()	2.2	17.5	10.0	15.5	15.0	0.8	0±0.8	1.3	1000	600
NEW ECWFE2W225P()	2.2	31.0	11.0	21.0	27.5	0.8	0±0.8	1.75	200	200
NEW ECWFE2W225Q()										
ECWFE2W335□()	3.3	26.0	10.0	17.0	22.5	0.8	0±0.8	1.8	500	300
NEW ECWFE2W335P()	3.3	31.0	13.0	23.0	27.5	0.8	0±0.8	1.75	200	200
NEW ECWFE2W335Q()										
ECWFE2W475□()	4.7	26.0	12.0	19.0	22.5	0.8	0±0.8	1.8	300	200
NEW ECWFE2W475P()	4.7	31.0	15.5	25.5	27.5	0.8	0±0.8	1.75	150	100
NEW ECWFE2W475Q()										

* □ : Capacitance tolerance code
 * () : Suffix for lead crimped

Note) Part number marked with bold is special lead space product.
 The capacitance of 0.10 μF, 0.15 μF, 0.22 μF, 0.33 μF, 3.3 μF, 4.7 μF are "5" or "D"
 The capacitance of 0.47 μF is "1" or "A"
 The capacitance of 1.5 μF, 2.2 μF are "8" or "L"

Rating · Dimensions · Quantity

■ Rated voltage : 630 V.DC, Capacitance tolerance : $\pm 5\%$ (J), $\pm 10\%$ (K)

Part No.	Cap. (μ F)	Dimensions (mm)							Min. order Q'ty (PCS)	
		L	T	H	F	Φ d	P	Q	Straight	Cut lead
ECWFE2J104□()	0.10	17.5	5.0	10.5	15.0	0.6	0 \pm 0.8	1.3	1000	1000
NEW ECWFE2J104P()	0.10	26.0	6.0	13.0	22.5	0.8	0 \pm 0.8	1.75	900	700
NEW ECWFE2J104Q()										
ECWFE2J154□()	0.15	17.5	6.0	11.5	15.0	0.6	0 \pm 0.8	1.3	1000	1000
NEW ECWFE2J154P()	0.15	26.0	6.0	13.0	22.5	0.8	0 \pm 0.8	1.75	900	700
NEW ECWFE2J154Q()										
ECWFE2J224□()	0.22	17.5	7.0	12.5	15.0	0.6	0 \pm 0.8	1.3	1000	1000
NEW ECWFE2J224P()	0.22	26.0	6.0	13.0	22.5	0.8	0 \pm 0.8	1.75	900	700
NEW ECWFE2J224Q()										
ECWFE2J334□()	0.33	17.5	8.5	14.5	15.0	0.6	0 \pm 0.8	1.3	1000	800
NEW ECWFE2J334P()	0.33	26.0	7.0	14.0	22.5	0.8	0 \pm 0.8	1.75	700	500
NEW ECWFE2J334Q()										
ECWFE2J474□()	0.47	17.5	10.0	15.5	15.0	0.6	0 \pm 0.8	1.3	1000	600
NEW ECWFE2J474P()	0.47	26.0	8.0	15.0	22.5	0.8	0 \pm 0.8	1.75	600	400
NEW ECWFE2J474Q()										
ECWFE2J684□()	0.68	17.5	11.0	17.5	15.0	0.6	0 \pm 0.8	1.3	600	600
ECWFE2J105□()	1.0	26.0	10.0	17.0	22.5	0.8	0 \pm 0.8	1.8	500	300
NEW ECWFE2J105P()	1.0	31.0	9.0	19.0	27.5	0.8	0 \pm 0.8	1.75	400	
NEW ECWFE2J105Q()										
ECWFE2J155□()	1.5	26.0	12.0	19.0	22.5	0.8	0 \pm 0.8	1.8	300	200
NEW ECWFE2J155P()	1.5	31.0	11.0	21.0	27.5	0.8	0 \pm 0.8	1.75	200	
NEW ECWFE2J155Q()										
ECWFE2J225□()	2.2	26.0	16.0	23.0	22.5	0.8	0 \pm 0.8	1.8	200	
NEW ECWFE2J225P()	2.2	31.0	13.0	23.0	27.5	0.8	0 \pm 0.8	1.75	200	
NEW ECWFE2J225Q()										

* □ : Capacitance tolerance code
* () : Suffix for lead crimped

Note) Part Number marked with bold is Special Lead space product.

The capacitance of 0.10 μ F, 0.15 μ F, 0.22 μ F, 0.33 μ F, 0.47 μ F, 1.0 μ F, 1.5 μ F, 2.2 μ F are "5" or "D"

Metalized Polypropylene Film Capacitor

Series : ECWH(V)

Non-inductive construction using metallized polypropylene film with flame retardant epoxy resin coating.

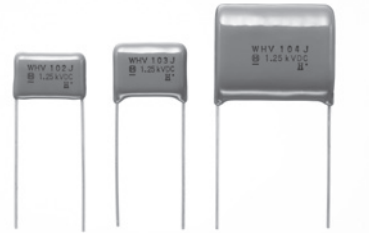

Features

- Low-loss
- Excellent electrical characteristics
- Flame retardant epoxy resin coating
- RoHS directive compliant

Recommended applications

- High frequency high voltage circuit
(General resonance, inverter circuit)

Explanation of part number

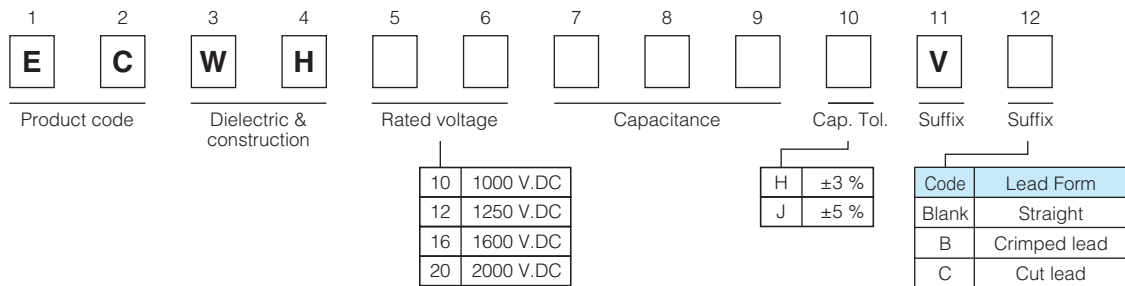

- Odd size taping

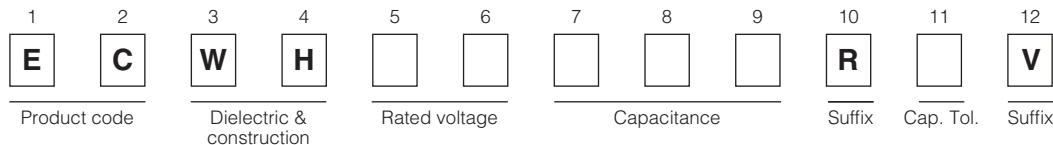

Specifications

Category temp. range (Including temperature-rise on unit surface)	- 40 °C to +105 °C	
Rated voltage	1000 V.DC, 1250 V.DC (1000 Vp-p) 1600 V.DC (1200 Vp-p), 2000 V.DC (1500 Vp-p) (Derating of rated voltage by 1.25 %/°C at more than 85 °C)	
Capacitance range	1000 V.DC	0.0075 μF to 0.10 μF
	1250 V.DC	0.0036 μF to 0.10 μF
	1600 V.DC	0.0013 μF to 0.056 μF
	2000 V.DC	0.001 μF to 0.015 μF
Capacitance tolerance	±3 % (H), ±5 % (J)	
Dissipation factor (tan δ)	tan δ ≤ 0.1 % (20 °C, 1 kHz) tan δ ≤ 0.2 % (20 °C, 10 kHz)	
Withstand voltage	Between terminals : Rated volt. (V.DC) × 150 %, 60 s Between terminals to enclosure : 1500 V.AC 60 s	
Insulation resistance (IR)	IR ≥ 30000 MΩ (20 °C, 500 V.DC, 60 s)	

* In case of applying voltage in alternating current (50 Hz or 60 Hz sine wave) to a capacitor with DC rated voltage, please refer to the page of "Permissible voltage (R.M.S) in alternating current corresponding to DC rated voltage".

Dimensions

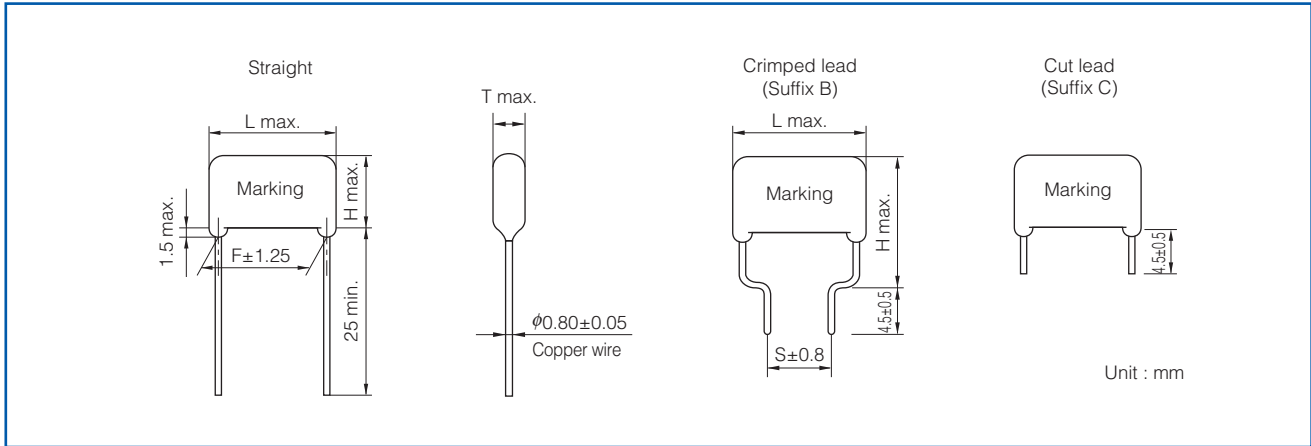

Packaging specifications for bulk package

- Packing quantity : 100 pcs./bag

Taping specifications for automatic insertion

- Taping style

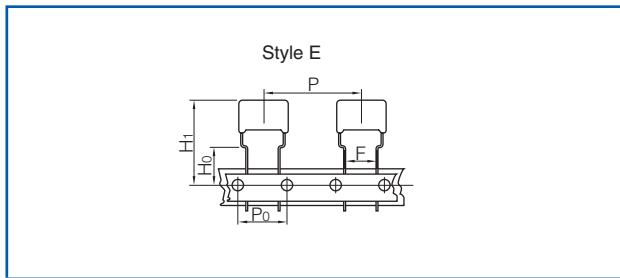

* Refer to the page of taping specifications.

- Taping style

Series	Rated voltage (V.DC)	Capacitance range (μF)	Taping style						Packing	suffix
			AD	AS	B	C	D	E		
ECWH(V)	1000	0.0075 to 0.10						○	Ammo	R() V
	1250	0.0036 to 0.051						○		R() V
	1600	0.0013 to 0.020						○		R() V
	2000	0.0010 to 0.015						○		R() V

* See the column "Rating · Dimensions · Quantity" for packing quantity

- Lead spacing

Style	Lead spacing
E	7.5 mm

Rating · Dimensions · Quantity

● Rated voltage : 1000 V.DC, Capacitance tolerance : $\pm 3\%$ (H), $\pm 5\%$ (J)

Part No.	Cap. (μ F)	Dimensions (mm)							Min. order Q'ty	
		L max.	T max.	H max.		F	S	ϕ d	Taping	Bulk
				Straight	Crimped lead				Straight	Crimped lead
ECWH10752□V()	0.0075	18.0	6.0	12.5	17.5	15.0	10.0	0.8	500	
ECWH10822□V()	0.0082	18.0	6.0	12.5	17.5	15.0	10.0	0.8		
ECWH10912□V()	0.0091	18.0	6.0	13.0	18.0	15.0	10.0	0.8		
ECWH10103□V()	0.010	18.0	6.5	13.0	18.0	15.0	10.0	0.8		
ECWH10113□V()	0.011	18.0	6.5	13.5	18.5	15.0	10.0	0.8		
ECWH10123□V()	0.012	18.0	6.5	13.5	18.5	15.0	10.0	0.8		
ECWH10133□V()	0.013	18.0	7.0	13.5	18.5	15.0	10.0	0.8		
ECWH10153□V()	0.015	18.0	7.0	14.0	19.0	15.0	10.0	0.8		
ECWH10163□V()	0.016	18.0	7.5	14.0	19.0	15.0	10.0	0.8		
ECWH10183□V()	0.018	18.0	7.5	14.5	19.5	15.0	10.0	0.8		
ECWH10203□V()	0.020	18.0	8.0	15.0	20.0	15.0	10.0	0.8	400	
ECWH10223□V()	0.022	18.0	8.5	15.0	20.0	15.0	10.0	0.8		
ECWH10243□V()	0.024	18.0	8.5	15.5	20.5	15.0	10.0	0.8		
ECWH10273□V()	0.027	18.0	9.0	16.0	21.0	15.0	10.0	0.8	300	500
ECWH10303□V()	0.030	18.0	9.5	16.5	21.5	15.0	10.0	0.8		
ECWH10333□V()	0.033	23.0	7.5	16.0	21.0	20.0	15.0	0.8	400	
ECWH10363□V()	0.036	23.0	7.5	16.0	21.0	20.0	15.0	0.8		
ECWH10393□V()	0.039	23.0	8.0	16.5	21.5	20.0	15.0	0.8		
ECWH10433□V()	0.043	23.0	8.5	16.5	21.5	20.0	15.0	0.8		
ECWH10473□V()	0.047	23.0	8.5	17.0	22.0	20.0	15.0	0.8		
ECWH10513□V()	0.051	23.0	9.0	17.5	22.5	20.0	15.0	0.8	300	
ECWH10563□V()	0.056	23.0	9.5	17.5	22.5	20.0	15.0	0.8		
ECWH10623□V()	0.062	23.0	9.5	18.0	23.0	20.0	15.0	0.8		
ECWH10683□V()	0.068	23.0	10.0	19.0	24.0	20.0	15.0	0.8		
ECWH10753□V()	0.075	23.0	10.5	19.5	24.5	20.0	15.0	0.8		
ECWH10823□V()	0.082	23.0	11.0	20.0	25.0	20.0	15.0	0.8		
ECWH10913□V()	0.091	23.0	11.5	20.5	25.5	20.0	15.0	0.8		
ECWH10104□V()	0.10	23.0	12.0	21.0	26.0	20.0	15.0	0.8		

* □ : Capacitance tolerance code
() : Suffix for lead crimped

Rating · Dimensions · Quantity

● Rated voltage : 1250 V.DC, Capacitance tolerance : $\pm 3\%$ (H), $\pm 5\%$ (J)

Part No.	Cap. (μ F)	Dimensions (mm)							Min. order Q'ty					
		L max.	T max.	H max.		F	S	ϕ d	Taping	Bulk				
				Straight	Crimped lead	Straight	Crimped lead		7.5 mm	Straight	Crimped lead			
ECWH12362□V()	0.0036	18.0	6.0	12.5	17.5	15.0	10.0	0.8	500	500	500			
ECWH12392□V()	0.0039	18.0	6.0	12.5	17.5	15.0	10.0	0.8						
ECWH12432□V()	0.0043	18.0	6.0	13.0	18.0	15.0	10.0	0.8						
ECWH12472□V()	0.0047	18.0	6.0	13.0	18.0	15.0	10.0	0.8						
ECWH12512□V()	0.0051	18.0	6.5	13.0	18.0	15.0	10.0	0.8						
ECWH12562□V()	0.0056	18.0	6.5	13.5	18.5	15.0	10.0	0.8						
ECWH12622□V()	0.0062	18.0	6.5	13.5	18.5	15.0	10.0	0.8						
ECWH12682□V()	0.0068	18.0	7.0	13.5	18.5	15.0	10.0	0.8						
ECWH12752□V()	0.0075	18.0	7.0	14.0	19.0	15.0	10.0	0.8						
ECWH12822□V()	0.0082	18.0	7.5	14.0	19.0	15.0	10.0	0.8						
ECWH12912□V()	0.0091	18.0	7.5	14.5	19.5	15.0	10.0	0.8						
ECWH12103□V()	0.010	18.0	8.0	15.0	20.0	15.0	10.0	0.8	400	500	500			
ECWH12113□V()	0.011	18.0	8.5	15.0	20.0	15.0	10.0	0.8						
ECWH12123□V()	0.012	18.0	8.5	15.5	20.5	15.0	10.0	0.8						
ECWH12133□V()	0.013	18.0	9.0	15.5	20.5	15.0	10.0	0.8						
ECWH12153□V()	0.015	18.0	9.5	16.0	21.0	15.0	10.0	0.8	500	500	500			
ECWH12163□V()	0.016	23.0	7.5	16.0	21.0	20.0	15.0	0.8						
ECWH12183□V()	0.018	23.0	7.5	16.0	21.0	20.0	15.0	0.8	400	500	500			
ECWH12203□V()	0.020	23.0	8.0	16.5	21.5	20.0	15.0	0.8						
ECWH12223□V()	0.022	23.0	8.5	16.5	21.5	20.0	15.0	0.8	400	500	500			
ECWH12243□V()	0.024	23.0	8.5	17.0	22.0	20.0	15.0	0.8						
ECWH12273□V()	0.027	23.0	9.0	17.5	22.5	20.0	15.0	0.8	300	500	500			
ECWH12303□V()	0.030	23.0	9.5	18.0	23.0	20.0	15.0	0.8						
ECWH12333□V()	0.033	23.0	10.0	18.5	23.5	20.0	15.0	0.8						
ECWH12363□V()	0.036	23.0	10.0	19.0	24.0	20.0	15.0	0.8						
ECWH12393□V()	0.039	23.0	10.5	19.5	24.5	20.0	15.0	0.8						
ECWH12433□V()	0.043	23.0	11.0	20.0	25.0	20.0	15.0	0.8						
ECWH12473□V()	0.047	23.0	11.5	20.5	25.5	20.0	15.0	0.8						
ECWH12513□V()	0.051	23.0	12.0	21.0	26.0	20.0	15.0	0.8						
ECWH12563□V()	0.056	28.0	11.5	20.0	25.0	25.0	17.5	0.8				-	500	500
ECWH12623□V()	0.062	28.0	12.0	21.0	26.0	25.0	17.5	0.8						
ECWH12683□V()	0.068	28.0	12.5	21.5	26.5	25.0	17.5	0.8						
ECWH12753□V()	0.075	28.0	13.5	22.0	27.0	25.0	17.5	0.8						
ECWH12823□V()	0.082	28.0	14.0	22.5	27.5	25.0	17.5	0.8						
ECWH12913□V()	0.091	28.0	14.5	23.0	28.0	25.0	17.5	0.8						
ECWH12104□V()	0.10	28.0	15.5	24.0	29.0	25.0	17.5	0.8						

* □ : Capacitance tolerance code
() : Suffix for lead crimped

Rating · Dimensions · Quantity

● Rated voltage : 1600 V.DC, Capacitance tolerance : $\pm 3\%$ (H), $\pm 5\%$ (J)

Part No.	Cap. (μ F)	Dimensions (mm)							Min. order Q'ty		
		L max.	T max.	H max.		F	S	ϕ d	Taping	Bulk	
				Straight	Crimped lead				7.5 mm	Straight	Crimped lead
ECWH16132□V()	0.0013	18.0	6.5	13.0	18.0	15.0	10.0	0.8	500		
ECWH16152□V()	0.0015	18.0	6.5	13.5	18.5	15.0	10.0	0.8			
ECWH16162□V()	0.0016	18.0	7.0	13.5	18.5	15.0	10.0	0.8			
ECWH16182□V()	0.0018	18.0	7.0	14.0	19.0	15.0	10.0	0.8			
ECWH16202□V()	0.0020	18.0	7.0	14.0	19.0	15.0	10.0	0.8			
ECWH16222□V()	0.0022	18.0	6.5	13.5	18.5	15.0	10.0	0.8			
ECWH16242□V()	0.0024	18.0	7.0	13.5	18.5	15.0	10.0	0.8			
ECWH16272□V()	0.0027	18.0	7.0	14.0	19.0	15.0	10.0	0.8			
ECWH16302□V()	0.003	18.0	7.5	14.0	19.0	15.0	10.0	0.8	400		
ECWH16332□V()	0.0033	18.0	7.5	14.5	19.5	15.0	10.0	0.8			
ECWH16362□V()	0.0036	18.0	7.0	13.5	18.5	15.0	10.0	0.8	500		
ECWH16392□V()	0.0039	18.0	7.0	14.0	19.0	15.0	10.0	0.8			
ECWH16432□V()	0.0043	18.0	7.0	14.0	19.0	15.0	10.0	0.8			
ECWH16472□V()	0.0047	23.0	6.5	14.5	19.5	20.0	15.0	0.8			
ECWH16512□V()	0.0051	23.0	6.5	15.0	20.0	20.0	15.0	0.8			
ECWH16562□V()	0.0056	23.0	6.5	15.0	20.0	20.0	15.0	0.8			
ECWH16622□V()	0.0062	23.0	7.0	15.0	20.0	20.0	15.0	0.8			
ECWH16682□V()	0.0068	23.0	7.0	15.5	20.5	20.0	15.0	0.8			
ECWH16752□V()	0.0075	23.0	7.5	15.5	20.5	20.0	15.0	0.8	400	500	500
ECWH16822□V()	0.0082	23.0	7.5	16.0	21.0	20.0	15.0	0.8			
ECWH16912□V()	0.0091	23.0	8.0	16.0	21.0	20.0	15.0	0.8			
ECWH16103□V()	0.010	23.0	8.0	16.5	21.5	20.0	15.0	0.8			
ECWH16113□V()	0.011	23.0	8.5	17.0	22.0	20.0	15.0	0.8	300		
ECWH16123□V()	0.012	23.0	9.0	17.0	22.0	20.0	15.0	0.8			
ECWH16133□V()	0.013	23.0	9.0	17.5	22.5	20.0	15.0	0.8			
ECWH16153□V()	0.015	23.0	9.5	18.0	23.0	20.0	15.0	0.8			
ECWH16163□V()	0.016	23.0	10.0	18.5	23.5	20.0	15.0	0.8			
ECWH16183□V()	0.018	23.0	10.5	19.5	24.5	20.0	15.0	0.8			
ECWH16203□V()	0.020	23.0	11.0	20.0	25.0	20.0	15.0	0.8	-		
ECWH16223□V()	0.022	28.0	9.5	18.0	23.0	25.0	17.5	0.8			
ECWH16243□V()	0.024	28.0	10.0	18.5	23.5	25.0	17.5	0.8			
ECWH16273□V()	0.027	28.0	10.5	19.5	24.5	25.0	17.5	0.8			
ECWH16303□V()	0.030	28.0	11.0	20.0	25.0	25.0	17.5	0.8			
ECWH16333□V()	0.033	28.0	11.5	20.5	25.5	25.0	17.5	0.8			
ECWH16363□V()	0.036	28.0	12.5	21.5	26.5	25.0	17.5	0.8			
ECWH16393□V()	0.039	28.0	13.5	22.0	27.0	25.0	17.5	0.8			
ECWH16433□V()	0.043	28.0	14.5	22.5	27.5	25.0	17.5	0.8			
ECWH16473□V()	0.047	28.0	15.0	23.5	28.5	25.0	17.5	0.8			
ECWH16513□V()	0.051	28.0	15.5	24.0	29.0	25.0	17.5	0.8			
ECWH16563□V()	0.056	28.0	16.0	24.5	29.5	25.0	17.5	0.8			

* □ : Capacitance tolerance code
() : Suffix for lead crimped

Rating · Dimensions · Quantity

● Rated voltage : 2000 V.DC, Capacitance tolerance : $\pm 3\%$ (H), $\pm 5\%$ (J)

Part No.	Cap. (μ F)	Dimensions (mm)							Min. order Q'ty	
		L max.	T max.	H max.		F	S		Taping	Bulk
				Straight	Crimped lead		Straight	Crimped lead	ϕ d	7.5 mm
ECWH20102□V()	0.0010	18.0	6.5	13.5	18.5	15.0	10.0	0.8	500	500
ECWH20112□V()	0.0011	18.0	6.5	13.5	18.5	15.0	10.0	0.8		
ECWH20122□V()	0.0012	18.0	7.0	13.5	18.5	15.0	10.0	0.8		
ECWH20132□V()	0.0013	18.0	7.0	14.0	19.0	15.0	10.0	0.8		
ECWH20152□V()	0.0015	18.0	7.5	14.0	19.0	15.0	10.0	0.8	400	
ECWH20162□V()	0.0016	18.0	7.5	14.5	19.5	15.0	10.0	0.8		
ECWH20182□V()	0.0018	18.0	8.0	14.5	19.5	15.0	10.0	0.8		
ECWH20202□V()	0.0020	18.0	8.0	15.0	20.0	15.0	10.0	0.8		
ECWH20222□V()	0.0022	18.0	8.5	15.0	20.0	15.0	10.0	0.8	300	
ECWH20242□V()	0.0024	18.0	8.5	15.5	20.5	15.0	10.0	0.8		
ECWH20272□V()	0.0027	18.0	9.0	16.0	21.0	15.0	10.0	0.8		
ECWH20302□V()	0.0030	18.0	9.5	16.0	21.0	15.0	10.0	0.8		
ECWH20332□V()	0.0033	18.0	8.5	15.5	20.5	15.0	10.0	0.8	400	
ECWH20362□V()	0.0036	18.0	9.0	15.5	20.5	15.0	10.0	0.8	300	
ECWH20392□V()	0.0039	18.0	9.0	16.0	21.0	15.0	10.0	0.8		
ECWH20432□V()	0.0043	18.0	9.5	16.0	21.0	15.0	10.0	0.8		
ECWH20472□V()	0.0047	23.0	7.0	15.5	20.5	20.0	15.0	0.8	500	
ECWH20512□V()	0.0051	23.0	7.5	16.0	21.0	20.0	15.0	0.8	400	
ECWH20562□V()	0.0056	23.0	7.5	16.0	21.0	20.0	15.0	0.8		
ECWH20622□V()	0.0062	23.0	8.0	16.5	21.5	20.0	15.0	0.8		
ECWH20682□V()	0.0068	23.0	8.5	16.5	21.5	20.0	15.0	0.8		
ECWH20752□V()	0.0075	23.0	9.5	18.0	23.0	20.0	15.0	0.8	300	
ECWH20822□V()	0.0082	23.0	10.0	18.0	23.0	20.0	15.0	0.8		
ECWH20912□V()	0.0091	23.0	10.0	19.0	24.0	20.0	15.0	0.8		
ECWH20103□V()	0.010	23.0	10.5	19.5	24.5	20.0	15.0	0.8		
ECWH20113□V()	0.011	23.0	11.0	20.0	25.0	20.0	15.0	0.8		
ECWH20123□V()	0.012	23.0	11.5	20.5	25.5	20.0	15.0	0.8		
ECWH20133□V()	0.013	23.0	12.0	21.0	26.0	20.0	15.0	0.8		
ECWH20153□V()	0.015	23.0	12.0	21.5	26.5	20.0	15.0	0.8		

* □ : Capacitance tolerance code
() : Suffix for lead crimped

Metallized Polypropylene Film Capacitor

Series : **ECWH(A)**

Non-inductive construction using metallized polypropylene film with flame retardant epoxy resin coating



Features

- Small size
- Excellent electrical characteristics
- Low loss
- Low Hum Sound Noise
- Flame retardant epoxy resin coating
- RoHS directive compliant

Recommended applications

- General resonance circuit

Explanation of part number

- Rated voltage 800 V.DC (Bulk)

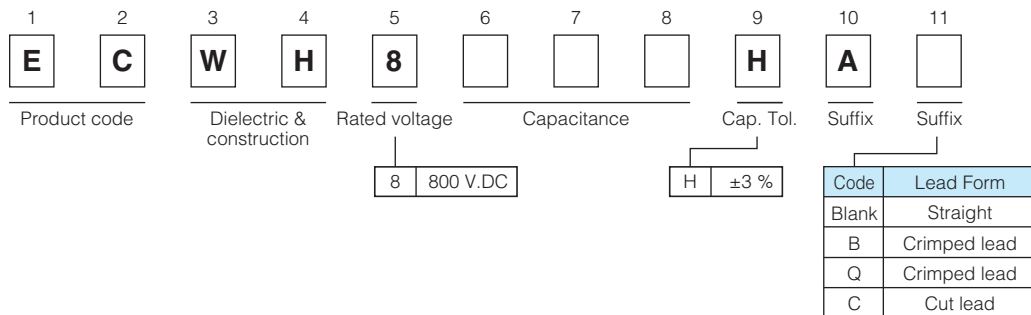

- Rated voltage 800 V.DC (Odd size taping)

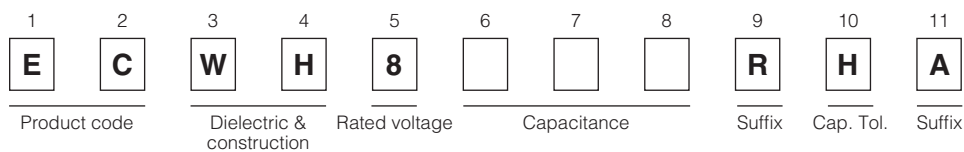

- Rated voltage 1600 V.DC

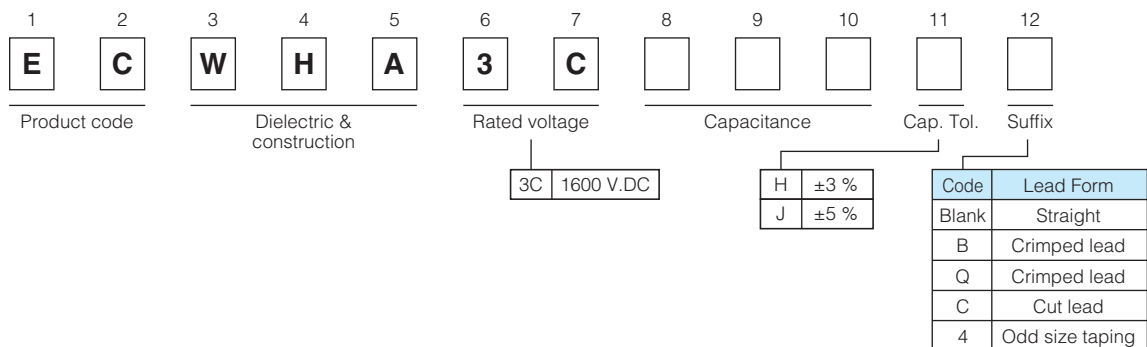

Specifications

Category temp. range (Including temperature-rise on unit surface)	- 40 °C to +105 °C	
Rated voltage	800 V.DC	1600 V.DC
Capacitance range	0.010 μF to 0.047 μF	0.0010 μF to 0.047 μF
Capacitance tolerance	±3 % (H)	±3 % (H), ±5 % (J)
Dissipation factor (tan δ)	tan δ ≤ 0.1 % (20 °C, 1 kHz)	
Withstand voltage	Between terminals : Rated volt. (V.DC) × 150 %, 60 s	
Insulation resistance (IR)	IR ≥ 30000 MΩ (20 °C, 500 V.DC, 60 s)	

* In case of applying voltage in alternating current (50 Hz or 60 Hz sine wave) to a capacitor with DC rated voltage, please refer to the page of "Permissible voltage (R.M.S) in alternating current corresponding to DC rated voltage".

Dimensions

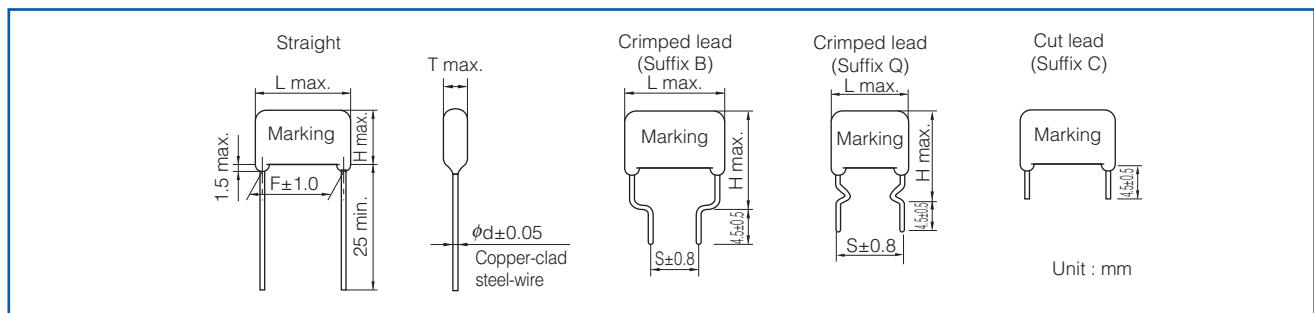

Packaging specifications for bulk package

- Packing quantity : 100 pcs./bag

Taping specifications for automatic insertion

- Taping style

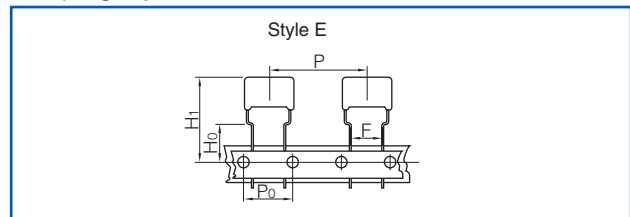

* Refer to the page of taping specifications.

- Taping style

Series	Rated voltage (V.DC)	Capacitance range (μF)	Taping style						Packing	suffix
			AD	AS	B	C	D	E		
ECWH(A)	800	0.010 to 0.047						○	Ammo	RHA
	1600	0.0010 to 0.047						○		() 4

- Lead spacing

Style	Lead spacing
E	7.5 mm

Rating · Dimensions · Quantity

- Rated voltage : 800 V.DC, Capacitance tolerance : ±3 % (H)

Part No.	Cap. (μF)	Dimensions (mm)									Min. order Q'ty	
		L max.	T max.	H max.			F	S		φd	Taping	Bulk
				Straight	Crimped lead (Suffix B)	Crimped lead (Suffix Q)		Crimped lead (Suffix B)	Crimped lead (Suffix Q)		7.5 mm	Straight · Crimped lead
ECWH8103HA()	0.010	15.4	5.4	9.8	14.8	14.8	12.5	7.5	12.5	0.6	500	
ECWH8123HA()	0.012	15.4	5.8	10.2	15.2	15.2	12.5	7.5	12.5	0.6		
ECWH8153HA()	0.015	15.4	6.2	10.6	15.6	15.6	12.5	7.5	12.5	0.6		
ECWH8183HA()	0.018	15.7	6.6	11.0	16.0	18.0	12.5	7.5	12.5	0.8		
ECWH8223HA()	0.022	15.7	7.1	11.5	16.5	18.5	12.5	7.5	12.5	0.8		
ECWH8273HA()	0.027	15.7	7.6	12.0	17.0	19.0	12.5	7.5	12.5	0.8	400	500
ECWH8333HA()	0.033	15.7	8.4	12.8	17.8	19.8	12.5	7.5	12.5	0.8		
ECWH8393HA()	0.039	15.7	8.9	13.3	18.3	20.3	12.5	7.5	12.5	0.8		
ECWH8473HA()	0.047	15.7	9.7	14.1	19.1	21.1	12.5	7.5	12.5	0.8	300	

* H : Capacitance tolerance code
() : Suffix for lead crimped taped type

Rating · Dimensions · Quantity

● Rated voltage : 1600 V.DC, Capacitance tolerance : $\pm 3\%$ (H), $\pm 5\%$ (J)

Part No.	Cap. (μ F)	Dimensions (mm)									Min. order Q'ty		
		L max.	T max.	H max.			F	S		ϕ d	Taping		Bulk
				Straight	Crimped lead (Suffix B)	Crimped lead (Suffix Q)		Crimped lead (Suffix B)	Crimped lead (Suffix Q)		7.5 mm	Straight	Crimped lead
ECWHA3C102□()	0.0010	17.8	5.2		13.0	13.0		10.0	15.0	0.6	600		
ECWHA3C112□()	0.0011	17.8	5.4		13.1	13.1		10.0	15.0	0.6			
ECWHA3C122□()	0.0012	17.8	5.5		13.2	13.2		10.0	15.0	0.6	500		
ECWHA3C132□()	0.0013	17.8	5.7		13.4	13.4		10.0	15.0	0.6			
ECWHA3C152□()	0.0015	17.8	5.9		13.7	13.7		10.0	15.0	0.6			
ECWHA3C162□()	0.0016	17.8	6.1		13.9	13.9		10.0	15.0	0.6			
ECWHA3C182□()	0.0018	17.8	6.4		14.1	14.1		10.0	15.0	0.6	400	-	
ECWHA3C202□()	0.0020	17.8	6.6		14.3	14.3		10.0	15.0	0.6			
ECWHA3C222□()	0.0022	17.8	6.7		14.5	14.5		10.0	15.0	0.6	600		
ECWHA3C242□()	0.0024	17.8	7.0		14.7	14.7		10.0	15.0	0.6			
ECWHA3C272□()	0.0027	17.8	5.2		13.0	13.0		10.0	15.0	0.6	500		
ECWHA3C302□()	0.0030	17.8	5.5		13.2	13.2		10.0	15.0	0.6			
ECWHA3C332□()	0.0033	17.8	5.6		13.4	13.4		10.0	15.0	0.6			
ECWHA3C362□()	0.0036	17.8	5.7		13.5	13.5		10.0	15.0	0.6			
ECWHA3C392□()	0.0039	17.8	6.0		13.8	13.8		10.0	15.0	0.6	400		
ECWHA3C432□()	0.0043	17.8	6.2		13.9	13.9		10.0	15.0	0.6			
ECWHA3C472□()	0.0047	17.8	6.4	9.1	14.1	14.1	15.0	10.0	15.0	0.6	1000		
ECWHA3C512□()	0.0051	17.8	6.6	9.4	14.4	14.4	15.0	10.0	15.0	0.6			
ECWHA3C562□()	0.0056	17.8	6.8	9.6	14.6	14.6	15.0	10.0	15.0	0.6	500		
ECWHA3C622□()	0.0062	17.8	7.1	9.8	14.8	14.8	15.0	10.0	15.0	0.6			
ECWHA3C682□()	0.0068	17.8	6.1	12.1	17.1	17.1	15.0	10.0	15.0	0.6	400		
ECWHA3C752□()	0.0075	17.8	6.5	12.4	17.4	17.4	15.0	10.0	15.0	0.6			
ECWHA3C822□()	0.0082	17.8	6.8	12.7	17.7	17.7	15.0	10.0	15.0	0.6	500		
ECWHA3C912□()	0.0091	17.8	7.1	13.0	18.0	18.0	15.0	10.0	15.0	0.6			
ECWHA3C103□()	0.010	20.3	6.4	12.3	17.3	17.3	17.5	10.0	17.5	0.6	400		
ECWHA3C113□()	0.011	20.3	6.6	12.5	17.5	17.5	17.5	10.0	17.5	0.6			
ECWHA3C123□()	0.012	20.3	6.8	12.8	17.8	17.8	17.5	10.0	17.5	0.6	300		
ECWHA3C133□()	0.013	20.3	7.1	13.0	18.0	18.0	17.5	10.0	17.5	0.6			
ECWHA3C153□()	0.015	20.3	7.6	13.5	18.5	18.5	17.5	10.0	17.5	0.6	800		
ECWHA3C163□()	0.016	20.3	7.9	13.8	18.8	18.8	17.5	10.0	17.5	0.6			
ECWHA3C183□()	0.018	20.6	8.2	14.1	19.1	21.1	17.5	10.0	17.5	0.8	200		
ECWHA3C203□()	0.020	20.6	8.7	14.6	19.6	21.6	17.5	10.0	17.5	0.8			
ECWHA3C223□()	0.022	20.6	9.1	15.0	20.0	22.0	17.5	10.0	17.5	0.8	600		
ECWHA3C243□()	0.024	20.6	9.6	15.4	20.4	22.4	17.5	10.0	17.5	0.8			
ECWHA3C273□()	0.027	20.6	10.0	15.9	20.9	22.9	17.5	10.0	17.5	0.8	800		
ECWHA3C303□()	0.030	20.6	10.7	16.5	21.5	23.5	17.5	10.0	17.5	0.8			
ECWHA3C333□()	0.033	20.6	11.2	17.0	22.0	24.0	17.5	10.0	17.5	0.8	200		
ECWHA3C363□()	0.036	20.6	11.7	17.5	22.5	24.5	17.5	10.0	17.5	0.8			
ECWHA3C393□()	0.039	20.6	12.1	18.0	23.0	25.0	17.5	10.0	17.5	0.8	800		
ECWHA3C433□()	0.043	20.6	12.8	18.6	23.6	25.6	17.5	10.0	17.5	0.8			
ECWHA3C473□()	0.047	20.6	13.4	19.2	24.2	26.2	17.5	10.0	17.5	0.8	600		800

* □ : Capacitance tolerance code
() : Suffix for lead crimped taped type

Metallized Polypropylene Film Capacitor

Series : **ECWH(C)**

Non-inductive construction using metallized polypropylene film with flame retardant epoxy resin coating

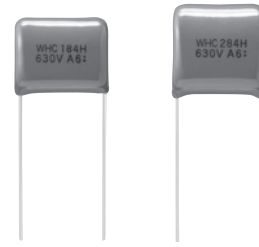

Features

- Excellent electrical characteristics
- Low loss
- Flame-retardant epoxy resin coating
- RoHS directive compliant

Recommended applications

- General resonance circuit (630 V.DC, 1250 V.DC)
- Resonance circuit for microwave oven and IH cooker (630 V.DC, 1250 V.DC)
- General high voltage circuit (3000 V.DC)

Explanation of part number

- Rated voltage 630 V.DC (Bulk)

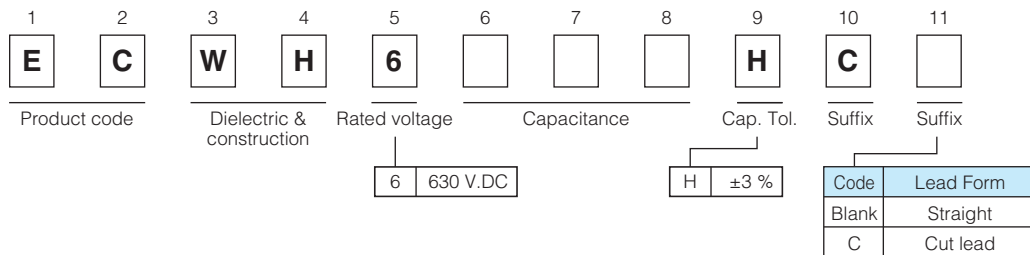

- Rated voltage 630 V.DC (Odd size taping)

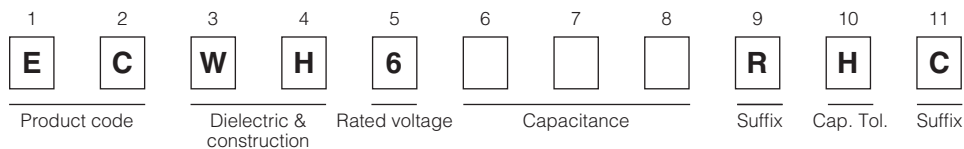

- Rated voltage 1250 V.DC (Cut lead)

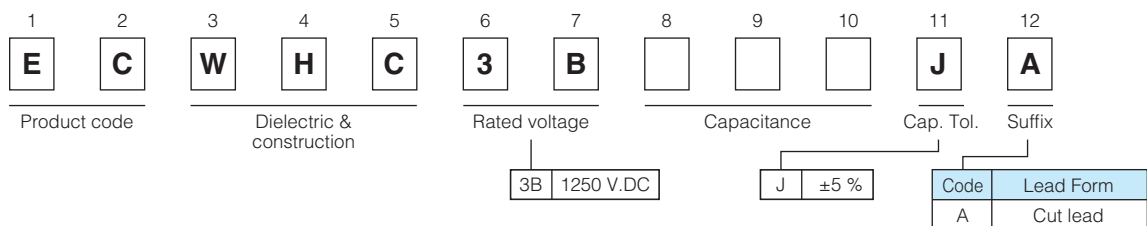

- Rated voltage 3000 V.DC (Bulk)

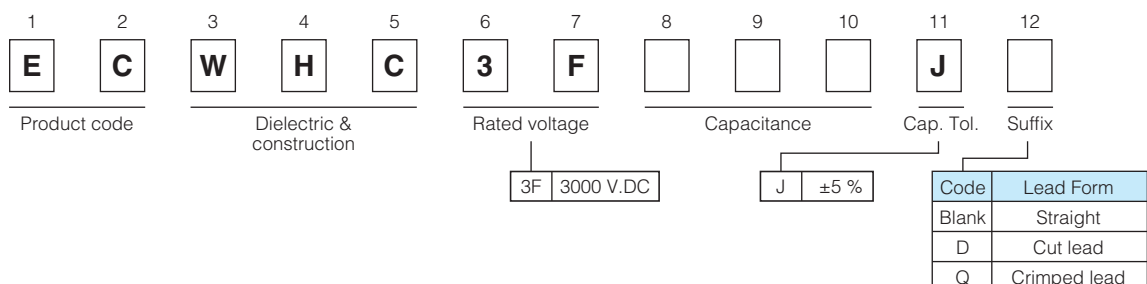

Specifications

Category temp. range (Including temperature-rise on unit surface)	630 V.DC	- 40 °C to +105 °C : General resonance circuit - 40 °C to +85 °C : When using compulsive air cooling for a resonance circuit
	1250 V.DC	- 40 °C to +105 °C : General resonance circuit - 40 °C to +85 °C : When using compulsive air cooling for a resonance circuit
	3000 V.DC	- 40 °C to +85 °C : General high voltage circuit
Rated voltage	630 VDC, 1250 VDC, 3000 VDC	
Capacitance range	630 V.DC	0.10 μF to 0.33 μF
	1250 V.DC	0.08 μF to 0.12 μF
	3000 V.DC	0.0024 μF to 0.01 μF
Capacitance tolerance	630 V.DC	±3 % (H)
	1250 V.DC	±5 % (J)
	3000 V.DC	±5 % (J)
Dissipation factor (tan δ)	630 V.DC	tan δ ≤ 0.05 % (20 °C, 1 kHz)
	1250 V.DC	tan δ ≤ 0.1 % (20 °C, 10 kHz)
	3000 V.DC	tan δ ≤ 0.1 % (20 °C, 1 kHz), tan δ ≤ 0.1 % (20 °C, 10 kHz)
Withstand voltage	630 V.DC	Between terminals : Rated volt. (V.DC) × 150 %, 60 s Between terminals : 6615 V.DC, 3 s
	1250 V.DC	
	3000 V.DC	
Insulation resistance (IR)	630 V.DC	IR ≥ 9000 MΩ (20 °C, 500 V.DC, 60 s) IR ≥ 50000 MΩ (20 °C, 500 V.DC, 60 s)
	1250 V.DC	
	3000 V.DC	

* In case of applying voltage in alternating current (50 Hz or 60 Hz sine wave) to a capacitor with DC rated voltage, please refer to the page of "Permissible voltage (R.M.S) in alternating current corresponding to DC rated voltage".

Dimensions

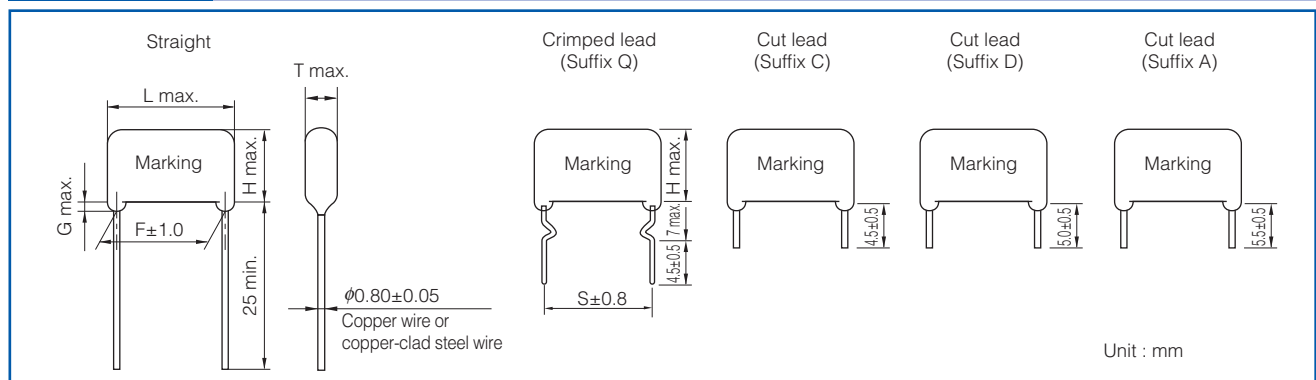

Packaging specifications for bulk package

- Packing quantity : 100 pcs./bag

Taping specifications for automatic insertion

- Taping style

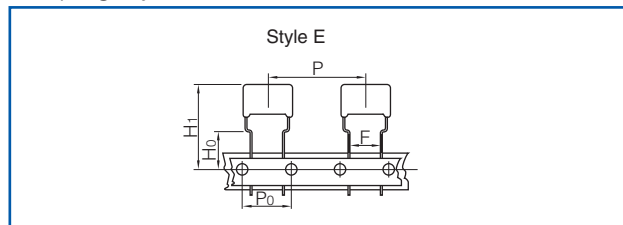

* Refer to the page of taping specifications.

- Taping style

Series	Rated voltage (V.DC)	Capacitance range (μF)	Taping style					Packing	
			AD	AS	B	C	D		E
ECWH(C)	630	0.10 to 0.21						○	Ammo

* See the column "Rating · Dimensions · Quantity" for packing quantity

- Lead spacing

Style	Lead spacing
E	7.5 mm

Rating · Dimensions · Quantity

● Rated voltage : 630 V.DC, Capacitance tolerance : $\pm 3\%$ (H)

Part No.	Capacitance (μF)	Dimensions (mm)						Min. order Q'ty	
		L max.	T max.	H max.	F	G max.	ϕd	Taping	Bulk
								7.5 mm	Straight · Crimped lead
ECWH6104HC()	0.10	20.7	8.6	13.5	17.5	1.5	0.8	350	1000
ECWH6114HC()	0.11	20.7	9.0	13.9	17.5	1.5	0.8	300	
ECWH6124HC()	0.12	20.7	9.4	14.3	17.5	1.5	0.8	250	
ECWH6184HC()	0.18	20.7	11.5	16.3	17.5	1.5	0.8	200	
ECWH6214HC()	0.21	20.7	12.4	17.2	17.5	1.5	0.8		
ECWH6244HC()	0.24	20.7	13.2	18.1	17.5	1.5	0.8	-	700
ECWH6274HC()	0.27	20.7	14.0	18.9	17.5	1.5	0.8		
ECWH6284HC()	0.28	20.7	14.3	19.1	17.5	1.5	0.8		
ECWH6304HC()	0.30	20.7	14.8	19.6	17.5	1.5	0.8		
ECWH6324HC()	0.32	20.7	14.5	20.9	17.5	1.5	0.8		
ECWH6334HC()	0.33	20.7	14.7	21.1	17.5	1.5	0.8		

* () : Suffix for lead form

● Rated voltage : 1250 V.DC, Capacitance tolerance : $\pm 5\%$ (J)

Part No.	Capacitance (μF)	Dimensions (mm)						Min. order Q'ty	
		L max.	T max.	H max.	F	G max.	ϕd	Bulk	
								Straight · Crimped lead	
ECWHC3B803JA	0.08	20.7	12.0	19.0	17.5	1.5	0.8	700	
ECWHC3B104JA	0.10	20.7	13.5	20.6	17.5	1.5	0.8		
ECWHC3B114JA	0.11	20.7	14.2	21.3	17.5	1.5	0.8		
ECWHC3B124JA	0.12	20.7	14.9	21.9	17.5	1.5	0.8	600	

● Rated voltage : 3000 V.DC, Capacitance tolerance : $\pm 5\%$ (J)

Part No.	Capacitance (μF)	Dimensions (mm)							Min. order Q'ty	
		L max.	T max.	H max.	F	S	G max.	ϕd	Bulk	
						Crimped lead (Suffix Q)			Straight · Crimped lead	
ECWHC3F242J()	0.0024	25.8	6.1	10.9	22.5	23.0	1.5	0.8	1000	
ECWHC3F362J()	0.0036	25.8	7.2	11.9	22.5	23.0	1.5	0.8		
ECWHC3F392J()	0.0039	25.8	7.5	12.2	22.5	23.0	1.5	0.8		
ECWHC3F432J()	0.0043	25.8	6.5	11.2	22.5	23.0	1.5	0.8		
ECWHC3F562J()	0.0056	25.8	7.3	12.0	22.5	23.0	1.5	0.8		
ECWHC3F822J()	0.0082	25.8	7.5	15.3	22.5	23.0	1.5	0.8		
ECWHC3F103J()	0.01	25.8	8.2	16.1	22.5	23.0	1.5	0.8		

* () : Suffix for lead form

Metalized Polypropylene Film Capacitors

Series : **TMF Series**
(for smoothing and resonance)



Features

- Wide voltage range up to 2300 V.AC
- High frequency and high current capability
- Low loss, Low ESR
- Long life time, High reliability
- Flame retardant
- RoHS directive compliant

Recommended applications

- Smoothing and resonance circuit, IH equipment and Industrial power supply

Construction

- Dielectric : Polypropylene film
- Electrodes : Metallized plastic film
- Plastic case : UL94 V-0
- Sealing : UL94 V-0
- Terminal : Lead wire (tin plating), Plate terminal (tin plating)

Explanation of part number

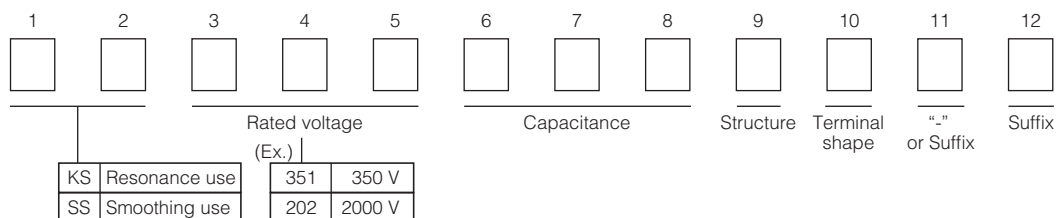

Note) Definition of AC or DC, please refer to an individual drawing

Specifications

	Smoothing circuit		Resonance circuit	
Rated voltage *1	150 V.AC to 220 V.AC 350 V.DC to 630 V.DC		300 V.AC to 2300 V.AC 500 V.DC to 1200 V.DC	
Rated capacitance *1	150 V.AC to 220 V.AC	1 μF to 10 μF	300 V.AC to 2300 V.AC	0.01 μF to 4.0 μF
	350 V.DC to 630 V.DC	1 μF to 10 μF	500 V.DC to 1200 V.DC	0.01 μF to 4.0 μF
Capacitance tolerance	Please refer to an individual drawing			
Withstand voltage	Please refer to an individual drawing			
Insulation resistance	Please refer to an individual drawing			
Maximum permissible temperature (Case wall)	85 °C (Including self temperature rising)			

*1 These are typical values. Please contact if necessary other Voltage and Capacitance.

Metalized Polypropylene Film Capacitor

Series : **ECQUA [Class X2]**

In accordance with UL/CSA and European safety regulation class X2
Equipped with a safety mechanism

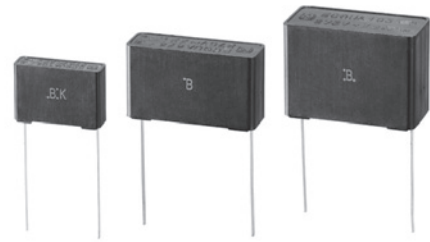

Features

- High humidity resistance
(THB test : 85 °C/85 %/240 V.AC/1000 h (C ≤ 1.0 μF))
- High safety (safety function installed)
- Compact
- Flame-retardant plastic case and non-combustible resin
- RoHS directive compliant

Recommended applications

- Interference suppressors

Explanation of part number

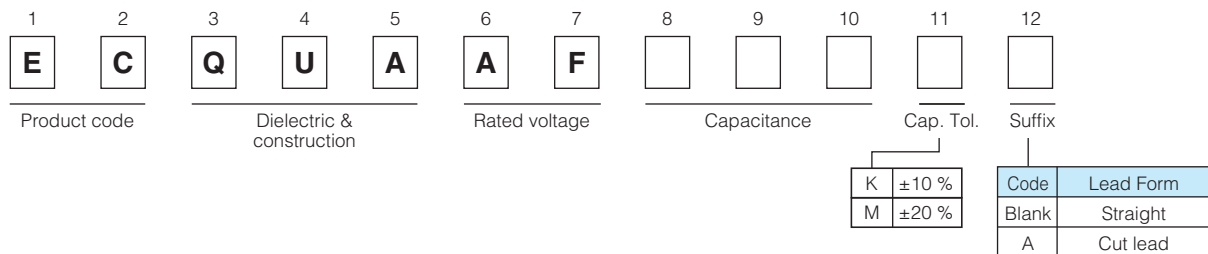

Applicable standard

* It is certified as type ECQUA in the following approval.

Approval		Class	Certification organization
UL	UL60384-14	Class X2	UL
CSA	CAN/CSA E60384-14	Class X2	
Europe	EN60384-14	Class X2	VDE
International	IEC60384-14	Class X2	

* When applying this capacitor to European and American safety standards, please use type designation and rating such as ECQUA, 0.1 μF.

* Approval number (File No.) of safety regulations are subject to revision without notice. Ask factory for a copy of the latest file No.

Specifications

Category temperature range	-40 °C to +110 °C
Rated voltage	275 V.AC
Rated capacitance	0.10 μF to 4.7 μF
Capacitance tolerance	±10 % (K), ±20 % (M)
Dissipation factor (tan δ)	C ≤ 1.0 μF : tan δ ≤ 0.1 % (20 °C, 1 kHz) C > 1.0 μF : tan δ ≤ 0.2 % (20 °C, 1 kHz)
Withstand voltage	Between terminals : 633 V.AC, 1183 V.DC, 60 s Between terminals to enclosure : 2050 V.AC, 60 s
Insulation resistance (IR)	C ≤ 0.33 μF : IR ≥ 15000 MΩ (20 °C, 100 V.DC, 60 s) C > 0.33 μF : IR ≥ 5000 MΩ · μF (20 °C, 100 V.DC, 60 s) C ≤ 0.47 μF : IR ≥ 2000 MΩ (20 °C, 500 V.DC, 60 s)
Maximum AC voltage *	310 V.AC

* Use of this capacitor is limited to AC voltage (50 Hz or 60 Hz sine wave).

* A faint corona discharge may occur inside of the capacitor element at rated voltage, however there is no influence on the reliability of the capacitor. (Suitable for series to the mains usage - for more details, please contact your Panasonic contact person.)

* Maximum AC voltage including line voltage fluctuation is 310 V.AC.

310 V.AC is not nominal continuous applied voltage, but only indicates maximum value including in the voltage of the power supply. Basic nominal voltage is considered as 240 V.AC.

This maximum AC voltage is specified in only ECQUA type, not specified in other types.

Please refer to individual product specification, and contact us for further questions regarding design life.

Design and specifications are each subject to change without notice. Ask factory for the current technical specifications before purchase and/or use.

Should a safety concern arise regarding this product, please be sure to contact us immediately.

Dimensions

Marking Example

(A) side	(B) or (C) side

Note : Only $\pm 10\%$ as cap. tol. be marked as "K".

Note : Date code.

Unit : mm

Rating · Dimensions · Quantity

- Capacitance tolerance : $\pm 10\%$ (K), $\pm 20\%$ (M)

Part No.	Cap. (μF)	Dimensions (mm)							Min. order Q'ty	
		L	T	H	F	ϕd	P	Q	Straight	Cut lead
ECQUAAF104□()	0.10	17.5	5.0	12.0	15.0	0.6	0 \pm 0.8	1.3	1000	1000
ECQUAAF154□()	0.15	17.5	6.0	13.0	15.0	0.6	0 \pm 0.8	1.3		
ECQUAAF224□()	0.22	17.5	7.5	14.0	15.0	0.6	0 \pm 0.8	1.3		
ECQUAAF334□()	0.33	17.5	9.0	16.0	15.0	0.6	0 \pm 0.8	1.3	600	800
ECQUAAF474□()	0.47	26.0	8.5	15.0	22.5	0.8	0 \pm 0.8	1.8		
ECQUAAF684□()	0.68	26.0	10.0	17.0	22.5	0.8	0 \pm 0.8	1.8	500	500
ECQUAAF105□()	1.0	26.0	12.0	19.0	22.5	0.8	0 \pm 0.8	1.8	300	300
ECQUAAF155□()	1.5	31.0	12.0	22.0	27.5	0.8	0 \pm 0.8	1.8	200	200
ECQUAAF225□()	2.2	31.0	14.5	24.5	27.5	0.8	0 \pm 0.8	1.8		
ECQUAAF335□()	3.3	31.0	19.0	29.0	27.5	0.8	0 \pm 0.8	1.8	150	150
ECQUAAF475□()	4.7	31.0	23.0	33.0	27.5	0.8	0 \pm 0.8	1.8	100	100

* □ : Capacitance tolerance code
 () : Suffix for lead form

Metalized Polyester Film Capacitor

Series : **ECQUL [Class X2]**
[Class Y2/X2]

In accordance with UL/CSA and European safety regulation class X2 or class Y2/X2

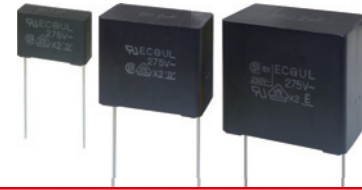

⚠ This series is not a recommended product. Not recommended for new design.

Features

- Compact
- Flame-retardant plastic case and non-combustible resin
- RoHS directive compliant

Recommended applications

- Interference suppressors

Explanation of part number

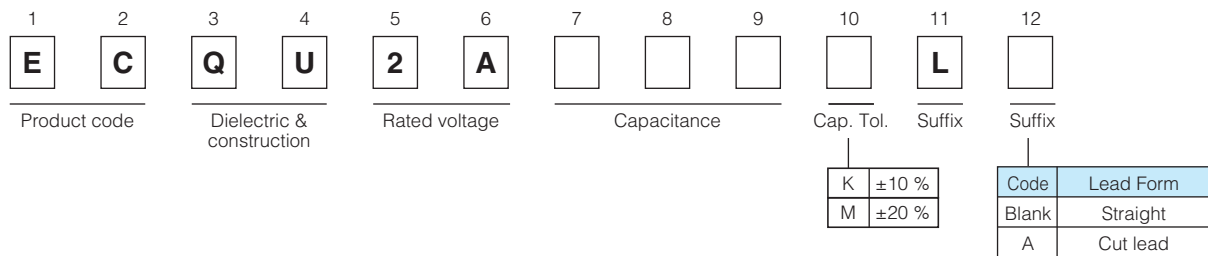

Applicable standard

* It is certified as type ECQUL in the following approval.

Approval		Class	Capacitance range	Certification organization
UL	UL60384-14	Class Y2/X2	(0.0010 μF to 0.0068 μF)	UL
		Class X2	(0.0082 μF to 2.2 μF)	
CSA	CAN/CSA E60384-14 CSA C22.2 No.8-M1986	Class Y2/X2	(0.0010 μF to 0.0068 μF)	CSA
		Class X2	(0.0082 μF to 2.2 μF)	
Europe	EN60384-14	Class Y2/X2	(0.0010 μF to 0.0068 μF)	VDE
		Class X2	(0.0082 μF to 2.2 μF)	
International	IEC60384-14	Class Y2/X2	(0.0010 μF to 0.0068 μF)	VDE
		Class X2	(0.0082 μF to 2.2 μF)	

* When applying this capacitor to European and American safety standards, please use type designation and rating such as ECQUL, 0.1 μF.

* Approval number (File No.) of safety regulations are subject to revision without notice. Ask factory for a copy of the latest file No.

* This capacitor is recognized for European standards by VDE only. But, there are no problems using this capacitor in a device which will get approvals from certification bodies in Europe, SEMKO, DEMKO, NEMKO, FIMKO and SEV etc.

Specifications

Category temperature range	-40 °C to +100 °C (85 °C max. on CSA C22.2 No.8 spec.)
Rated voltage	275 V.AC (250 V.AC on CSA C22.2 No.8 spec.)
Rated capacitance	0.0010 μF to 2.2 μF
Capacitance tolerance	±10 % (K), ±20 % (M)
Dissipation factor (tan δ)	tan δ ≤ 1.0 % (20 °C, 1 kHz)
Withstand voltage	Between terminals : 575 V.AC, 1768 V.DC, 60 s (0.0082 μF to 2.2 μF) Between terminals : 1500 V.AC, 2121 V.DC, 60 s (0.0010 μF to 0.0068 μF) Between terminals to enclosure : 2050 V.AC, 60 s
Insulation resistance (IR)	C ≤ 0.33 μF : IR ≥ 15000 MΩ (20 °C, 100 V.DC, 60 s) C > 0.33 μF : IR ≥ 5000 MΩ · μF (20 °C, 100 V.DC, 60 s) IR ≥ 2000 MΩ (20 °C, 500 V.DC, 60 s)

* Use of this capacitor is limited to AC voltage (50 Hz or 60 Hz sine wave).

Dimensions

STYLE	(A) side	(B) side
1 0.0010 μ F to 0.0068 μ F	M .001 μ F K	ECQUL 275V~ X2/Y2
2 0.0082 μ F to 1.0 μ F	M .0082 μ F K	ECQUL 275V~ X2
3 1.2 μ F to 2.2 μ F	M 1.5 μ F K	BX 250V~ ECQUL 275V~ X2

Note : Only $\pm 10\%$ as cap. tol. be marked as "K".

Note : Date code.

Unit : mm

* $\geq 1.2 \mu\text{F} \pm 1.0$

Rating · Dimensions · Quantity

- Capacitance tolerance : $\pm 10\%$ (K), $\pm 20\%$ (M)

Part No.	Capacitance (μ F)	Dimensions (mm)							Min. order Q'ty	
		L	T	H	F	ϕd	P	Q	Straight	Cut lead
ECQU2A102□L ()	0.0010	15.0	5.0	11.5	12.5	0.6	0 \pm 0.50	1.3	500	500
ECQU2A122□L ()	0.0012	15.0	5.0	11.5	12.5	0.6	0 \pm 0.50	1.3		
ECQU2A152□L ()	0.0015	15.0	5.0	11.5	12.5	0.6	0 \pm 0.50	1.3		
ECQU2A182□L ()	0.0018	15.0	5.0	11.5	12.5	0.6	0 \pm 0.50	1.3		
ECQU2A222□L ()	0.0022	15.0	5.0	11.5	12.5	0.6	0 \pm 0.50	1.3		
ECQU2A272□L ()	0.0027	15.0	5.0	11.5	12.5	0.6	0 \pm 0.50	1.3		
ECQU2A332□L ()	0.0033	15.0	5.0	11.5	12.5	0.6	0 \pm 0.50	1.3		
ECQU2A392□L ()	0.0039	15.0	5.0	11.5	12.5	0.6	0 \pm 0.50	1.3		
ECQU2A472□L ()	0.0047	15.0	5.0	11.5	12.5	0.6	0 \pm 0.50	1.3		
ECQU2A562□L ()	0.0056	15.0	5.0	11.5	12.5	0.6	0 \pm 0.50	1.3		
ECQU2A682□L ()	0.0068	15.0	5.0	11.5	12.5	0.6	0 \pm 0.50	1.3		
ECQU2A822□L ()	0.0082	15.0	5.0	11.5	12.5	0.6	0 \pm 0.50	1.3		
ECQU2A103□L ()	0.010	15.0	5.0	11.5	12.5	0.6	0 \pm 0.50	1.3		
ECQU2A123□L ()	0.012	15.0	5.0	11.5	12.5	0.6	0 \pm 0.50	1.3		
ECQU2A153□L ()	0.015	15.0	5.0	11.5	12.5	0.6	0 \pm 0.50	1.3		
ECQU2A183□L ()	0.018	15.0	5.0	11.5	12.5	0.6	0 \pm 0.50	1.3		
ECQU2A223□L ()	0.022	15.0	5.0	11.5	12.5	0.6	0 \pm 0.50	1.3		
ECQU2A273□L ()	0.027	15.0	5.0	11.5	12.5	0.6	0 \pm 0.50	1.3		
ECQU2A333□L ()	0.033	15.0	6.0	13.0	12.5	0.6	0 \pm 0.50	1.3		
ECQU2A393□L ()	0.039	15.0	6.0	13.0	12.5	0.6	0 \pm 0.50	1.3		
ECQU2A473□L ()	0.047	15.0	6.0	13.0	12.5	0.6	0 \pm 0.50	1.3		
ECQU2A563□L ()	0.056	17.5	4.5	11.5	15.0	0.6	0 \pm 0.50	1.3		
ECQU2A683□L ()	0.068	17.5	4.5	11.5	15.0	0.6	0 \pm 0.50	1.3		
ECQU2A823□L ()	0.082	17.5	5.5	12.0	15.0	0.6	0 \pm 0.50	1.3		
ECQU2A104□L ()	0.10	17.5	5.5	12.0	15.0	0.6	0 \pm 0.50	1.3		
ECQU2A124□L ()	0.12	17.5	6.5	14.5	15.0	0.6	0 \pm 0.50	1.3		
ECQU2A154□L ()	0.15	17.5	6.5	14.5	15.0	0.6	0 \pm 0.50	1.3		
ECQU2A184□L ()	0.18	17.5	8.0	16.0	15.0	0.6	0 \pm 0.50	1.3		
ECQU2A224□L ()	0.22	17.5	8.0	16.0	15.0	0.6	0 \pm 0.50	1.3		
ECQU2A274□L ()	0.27	17.5	9.5	17.5	15.0	0.8	0 \pm 0.50	1.3		
ECQU2A334□L ()	0.33	17.5	9.5	17.5	15.0	0.8	0 \pm 0.50	1.3		
ECQU2A394□L ()	0.39	25.5	8.5	17.5	22.5	0.8	0 \pm 0.75	1.5		
ECQU2A474□L ()	0.47	25.5	8.5	17.5	22.5	0.8	0 \pm 0.75	1.5		
ECQU2A564□L ()	0.56	25.5	10.5	19.5	22.5	0.8	0 \pm 0.75	1.5		
ECQU2A684□L ()	0.68	25.5	10.5	19.5	22.5	0.8	0 \pm 0.75	1.5		
ECQU2A824□L ()	0.82	25.5	12.0	22.0	22.5	0.8	0 \pm 0.75	1.5		
ECQU2A105□L ()	1.0	25.5	12.0	22.0	22.5	0.8	0 \pm 0.75	1.5		
ECQU2A125□L ()	1.2	30.5	16.5	26.0	27.5	0.8	0 \pm 0.75	1.5		
ECQU2A155□L ()	1.5	30.5	16.5	26.0	27.5	0.8	0 \pm 0.75	1.5		
ECQU2A185□L ()	1.8	30.5	19.0	29.5	27.5	0.8	0 \pm 0.75	1.5		
ECQU2A225□L ()	2.2	30.5	19.0	29.5	27.5	0.8	0 \pm 0.75	1.5		

* □ : Capacitance tolerance code
() : Suffix for lead form

Dimensions

Marking example

(A) side	(B) side
Ⓜ .01 μ F	ECQUG 300V~X1 10

Note : Date code.

Unit : mm

Rating · Dimensions · Quantity

- Capacitance tolerance : $\pm 20\%$ (M)

Part No.	Capacitance (μ F)	Dimensions (mm)							Min. order Q'ty	
		L	T	H	F	ϕd	P	Q	Straight	Cut lead
ECQU3A103MG()	0.010	15.0	5.0	11.5	12.5	0.6	0 \pm 0.50	1.3	500	500
ECQU3A153MG()	0.015	15.0	5.0	11.5	12.5	0.6	0 \pm 0.50	1.3		
ECQU3A223MG()	0.022	15.0	5.0	11.5	12.5	0.6	0 \pm 0.50	1.3		
ECQU3A333MG()	0.033	15.0	6.0	13.0	12.5	0.6	0 \pm 0.50	1.3		
ECQU3A473MG()	0.047	15.0	6.0	13.0	12.5	0.6	0 \pm 0.50	1.3		
ECQU3A683MG()	0.068	15.0	8.0	15.0	12.5	0.6	0 \pm 0.50	1.3		
ECQU3A104MG()	0.10	15.0	8.0	15.0	12.5	0.6	0 \pm 0.50	1.3		
ECQU3A154MG()	0.15	18.0	8.0	16.5	15.0	0.8	0 \pm 0.50	1.3		
ECQU3A224MG()	0.22	18.0	9.0	17.5	15.0	0.8	0 \pm 0.50	1.3		
ECQU3A334MG()	0.33	26.0	9.0	18.5	22.5	0.8	0 \pm 0.50	1.5		
ECQU3A474MG()	0.47	26.0	10.5	20.0	22.5	0.8	0 \pm 0.75	1.5	300	400
ECQU3A684MG()	0.68	26.0	12.5	22.0	22.5	0.8	0 \pm 0.75	1.5		300
ECQU3A105MG()	1.0	27.0	16.5	25.5	22.5	0.8	0 \pm 0.75	2.2		300

* () : Suffix for lead form

Film Capacitor for AC Motor

Series : **AMF Series**



Features

- High safety (Safety function installed)
- High reliability
- Small size, lightness, and low loss
- RoHS directive compliant

Recommended applications

- Motor and compressor (for running)

Construction

- Internal electrode : Metallized plastic film (Safety function installed)
- Plastic case : UL94 V-0
- Sealing : UL94 V-0
- Terminal : Faston terminal (tin plating)

Explanation of part number

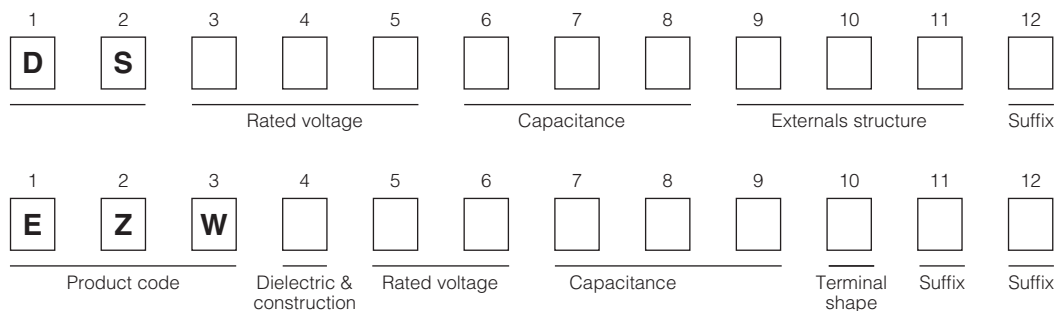

Applicable standard

Japan	JIS C 4908 Capacitors for electrical apparatus CMJ registration parts. Registration No.1475- C9902-026(JET)
UL/cUL	UL810/CSA C22.2 No. 190 FILE No. E76560

Specifications

Applicable standard *1		JIS UL
Safety class		Safety function installed P2 (CMJ approval), 10000 AFC (UL)
Rated voltage (50/60 Hz) *2		180 V.AC to 440 V.AC
Rated capacitance *2		10 μF to 40 μF
Capacitance tolerance		-5 %/+10 % (Refer to the individual drawing)
Withstand voltage	Between terminals	Rated voltage × 1.75, 60 s (min. 2000 V.AC)
	Between terminals to enclosure	Rated voltage × 2.0+1000 (V.AC), 60 s
Maximum permissible temperature (Case wall)		70 °C (Including self temperature rising)

*1 The range of approval is different depending on each approval.
*2 These are typical values.

Dimension (Example)^{*3}

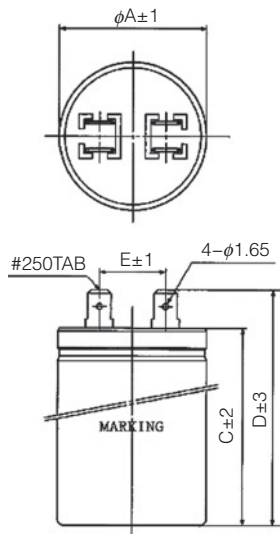

Unit : mm

*3 Other shape and specific requirement can be designed. Please contact, if necessary.

Rating · Dimensions^{*4}

Rated voltage (V.AC)	Capacitance (μ F)	Dimensions (mm)				
		A	B	C	D	E
440	10.0	40.0	60.0	70.5	18.0	16.0
	10.5 to 18.5	40.0	90.0	100.5	18.0	16.0
	19.0 to 27.5	40.0	120.0	130.5	18.0	16.0
	16.0 to 21.0	45.0	80.0	90.5	18.0	16.0
	21.5 to 25.0	45.0	90.0	100.5	18.0	16.0
	25.5 to 28.5	45.0	100.0	110.5	18.0	16.0
	29.0 to 36.5	45.0	120.0	130.5	18.0	18.0
	31.0 to 37.0	50.0	100.0	100.5	18.0	18.0
37.5 to 40.0	50.0	120.0	130.5	18.0	18.0	

*4 Please contact if necessary other Voltage and Capacitance.

Film Capacitor for AC Motor

Series : **DMF Series**



Features

- High safety (with built-in safety device)
- High reliability, Safety standard approval
- Small size, lightness, and low loss
- RoHS directive compliant

Recommended applications

- Motor and compressor (for running)

Construction

- Internal electrode : Metallized plastic film
- Exterior material : Metal case (oil sealing up type)
- Terminal : Faston terminal (tin plating)

Explanation of part number

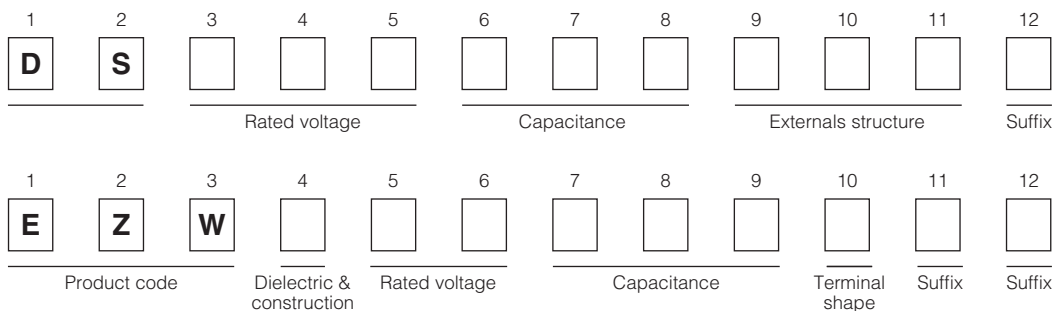

Applicable standard

Japan	JIS C 4908 Capacitors for electrical apparatus CMJ registration parts. Registration No.1475- C9902-026(JET)
UL/cUL	UL810/CSA C22.2 No. 190 FILE No. E76560
Europe	EN60252-1 AC motor Capacitors TUV
China	GB/T 3667.1 AC motor Capacitors CQC

Specifications

Applicable standard *1		JIS UL	EN GB
Safety class		With built-in safety device P1(CMJ approval) 10000 AFC (UL)	S2
Rated voltage (50/60 Hz) *2		180 V.AC to 450 V.AC	EN GB : 440 V.AC, 450 V.AC
Rated capacitance *2		10 μF to 60 μF	
Capacitance tolerance		-5 %/+10 %, ±5 % (Refer to the individual drawing)	
Withstand voltage	Between terminals	Rated voltage × 1.75, 60 s	Rated voltage × 2.0, 60 s
	Between terminals to enclosure	(min. 2000 V.AC) Rated voltage × 2.0+1000 (V.AC), 60 s	
Maximum permissible temperature (Case wall)		70 °C (Including self temperature rising)	

*1 The range of approval is different depending on each approval.

*2 These are typical values.

Dimension (Example)^{*3}

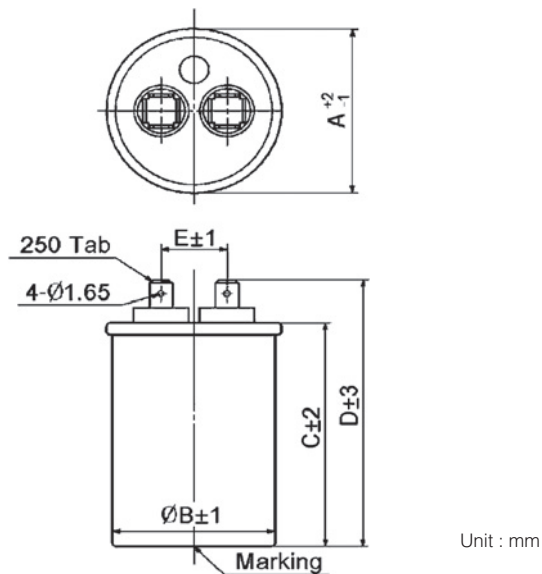

*3 Other shape and specific requirement can be designed. Please contact, if necessary.
Three tabs and as many as four tabs are also possible though standards of the number of terminal tabs are two tabs.

Rating · Dimensions^{*4}

Rated voltage (V.AC)	Capacitance (µF)	Dimensions (mm)				
		A	B	C	D	E
370 to 440	5.0 to 10.0	43.0	41.0	70.0	83.0	16.0
	11.0 to 15.0	43.0	41.0	80.0	93.0	16.0
	16.0 to 20.0	43.0	41.0	90.0	103.0	16.0
	21.0 to 25.0	43.0	41.0	100.0	113.0	16.0
	26.0 to 30.0	43.0	41.0	110.0	123.0	16.0
	31.0 to 35.0	43.0	41.0	130.0	143.0	16.0
	36.0 to 40.0	48.0	45.0	110.0	123.0	18.0
	41.0 to 50.0	48.0	45.0	130.0	143.0	18.0
	51.0 to 55.0	53.0	50.5	110.0	123.0	18.0
	56.0 to 60.0	63.0	60.5	90.0	103.0	20.0
	61.0 to 65.0	63.0	60.5	100.0	113.0	20.0

Rated voltage (V.AC)	Capacitance (µF)	Dimensions (mm)				
		A	B	C	D	E
450	5.0 to 10.0	43.0	41.0	70.0	83.0	16.0
	11.0 to 15.0	43.0	41.0	90.0	103.0	16.0
	16.0 to 20.0	43.0	41.0	110.0	123.0	16.0
	21.0 to 25.0	48.0	45.0	100.0	113.0	18.0
	26.0 to 30.0	48.0	45.0	110.0	123.0	18.0
	31.0 to 35.0	53.0	50.5	100.0	113.0	18.0
	36.0 to 40.0	53.0	50.5	110.0	123.0	18.0
	41.0 to 50.0	63.0	60.5	100.0	113.0	20.0
	51.0 to 55.0	63.0	60.5	110.0	123.0	20.0
	56.0 to 60.0	63.0	60.5	130.0	143.0	20.0

*4 Please contact if necessary other Voltage and Capacitance.

Film Capacitor for AC Motor

Series : **PMF**



Features

- High safety (safety function installed)
- High reliability, safety standard approval
- Small size, lightness, and low loss
- RoHS directive compliant

Recommended applications

- Motor and small compressor (for running)

Construction

- Internal electrode : Metallized plastic film (safety function installed)
- Plastic case : UL94 V-0
- Sealing : UL94 V-0
- Terminal : Faston terminal (tin plating), Lead wire (tin plating), Insulated wire

Explanation of part number

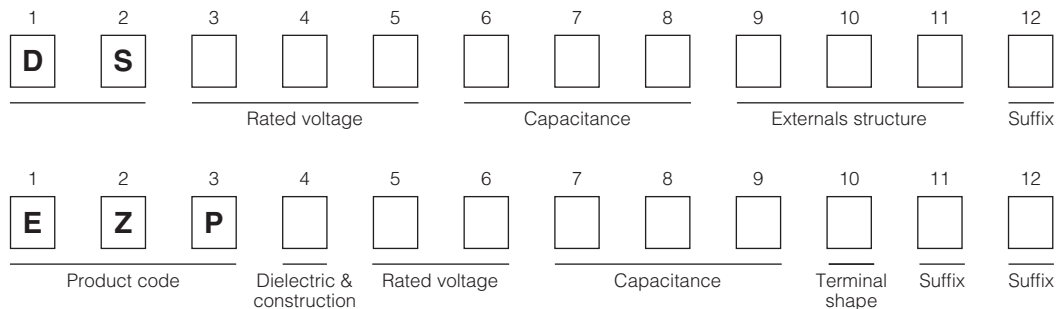

Applicable standard

Japan	JIS C 4908 Capacitors for electrical apparatus CMJ registration parts. Registration No.1475- C9902-026(JET)
UL/cUL CSA	UL810 FILE No. E76560 CSA C22.2 No. 190
Europe	EN60252-1 AC motor Capacitors TUV
China	GB/T 3667.1 AC motor Capacitors CQC

Specifications

Applicable standard *1		JIS UL	EN GB
Safety class		With built-in safety function P2 (CMJ approval) 10000 AFC (UL)	S3
Rated voltage (50/60 Hz) *2		150 V.AC to 500 V.AC (For UL Approved P/N : up to 480 V.AC)	EN/TUV : 450 V.AC GB : 250 V.AC, 450 V.AC
Rated capacitance *2		0.5 µF to 65 µF	
Capacitance tolerance		-5 %/+10 %, ±5 % (Refer to the individual drawing)	
Withstand voltage	Between terminals	Rated voltage × 1.75, 60 s	Rated voltage × 2.0, 60 s
	Between terminals to enclosure	(min. 2000 V) Rated voltage × 2.0+1000 (V), 60 s	
Maximum permissible temperature (Case wall)		70 °C (Including self temperature rising)	

*1 The range of approval is different depending on each approval.

*2 These are typical values.

Dimension (Example)^{*3}

- Q series (Mounting type) * Non Mounting type is available. (P series).

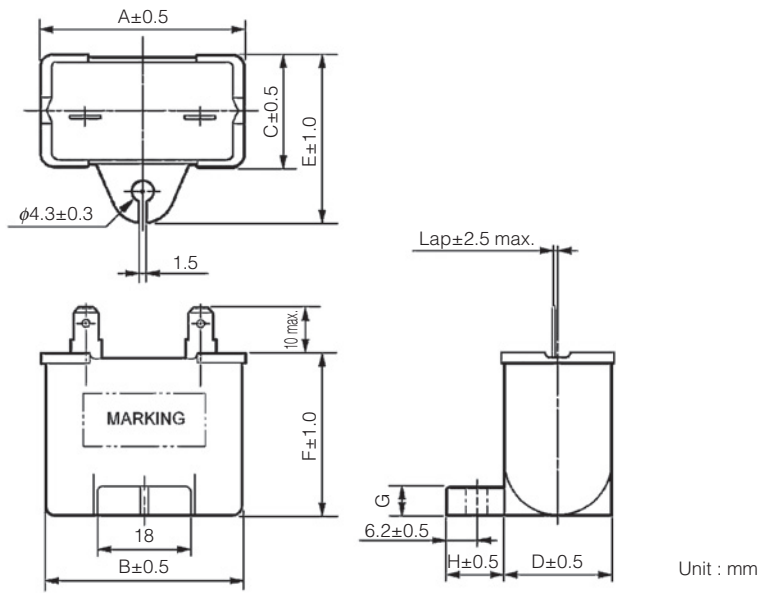

- T series (Printed circuit board (PCB))

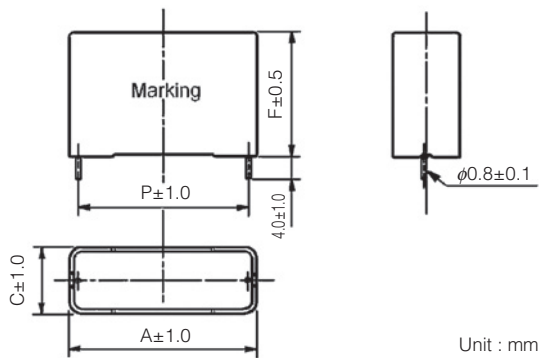

- Terminal shape (Standard)



^{*3} Other shape and specific requirement can be designed. Please contact, if necessary.

Rating · Dimensions*4

● Q series (Mounting type)

Rated voltage (V.AC)	Capacitance (μ F)	Dimensions (mm)								Case series
		A	B	C	D	E	F	G	H	
250	3.0 to 4.5	39.5	38.5	16.2	14.8	27.0	27.0	4.0	11.5	Q
	5.0 to 6.0	39.5	38.2	18.3	16.8	29.0	29.0			
	6.5 to 9.5	39.5	38.2	22.0	20.8	32.5	32.5			
	10.0 to 16.0	49.7	48.3	24.0	22.5	34.5	34.5			
	16.5 to 20.0	50.0	48.5	26.7	25.3	37.5	38.0			
	20.5 to 25.0	50.0	48.5	30.5	28.8	41.0	41.5			
	25.5 to 34.5	50.0	48.5	34.0	32.6	45.0	45.0	6.0		
450	1.0 to 1.4	39.5	38.5	16.2	14.8	27.0	27.0	4.0	11.5	
	1.5 to 1.8	39.5	38.2	18.3	16.8	29.0	29.0			
	1.9 to 2.5	39.5	38.2	22.0	20.8	32.5	32.5			
	3.0 to 5.0	49.7	48.3	24.0	22.5	34.5	34.5			
	5.5 to 6.5	50.0	48.5	26.7	25.3	37.5	38.0			
	7.0 to 8.0	50.0	48.5	30.5	28.8	41.0	41.5			
	8.5 to 10.5	50.0	48.5	34.0	32.6	45.0	45.0	6.0		

● T series (Printed circuit board (PCB))

Rated voltage (V.AC)	Capacitance (μ F)	Dimensions (mm)				Case series
		A	C	F	P	
250	3.0 to 4.0	38.5	14.0	25.5	36.0	T
	4.5 to 6.5	38.5	15.5	29.0	36.0	
	7.0 to 8.0	38.5	20.5	29.0	36.0	
	8.5 to 11.0	38.5	25.0	34.0	36.0	
	11.5 to 18.5	48.5	22.0	36.0	46.0	
450	1.0 to 1.3	38.5	14.0	25.5	36.0	
	1.4 to 2.0	38.5	15.5	29.0	36.0	
	2.1 to 2.5	38.5	20.5	29.0	36.0	
	3.0 to 3.5	38.5	25.0	34.0	36.0	
	4.0 to 5.5	48.5	22.0	36.0	46.0	

*4 Please contact if necessary other Voltage and Capacitance.

Film Capacitor for AC Motor

Series : **SMF**



Features

- High safety (safety function installed)
- High reliability, safety standard approval
- Small size, lightness, and low loss
- RoHS directive compliant

Recommended applications

- Motor and small compressor (for running)

Construction

- Internal electrode : Metallized plastic film (safety function installed)
- Plastic case : UL94 V-0
- Sealing : UL94 V-0
- Terminal : Faston terminal (tin plating), Lead wire (tin plating), Insulated wire

Explanation of part number

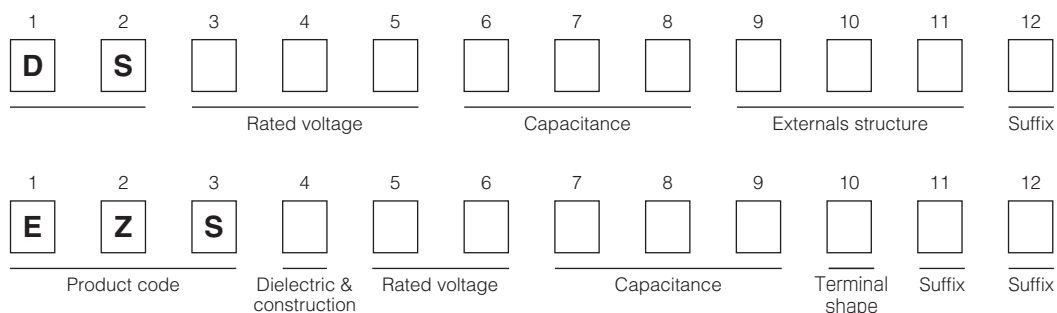

Applicable standard

Japan	JIS C 4908 Capacitors for electrical apparatus CMJ registration parts. Registration No.1475- C9902-026(JET)
UL/cUL	UL810 FILE No. E76560
Europe	EN60252-1 AC motor Capacitors VDE
China	GB/T 3667.1 AC motor Capacitors CQC

Specifications

Applicable standard *1		JIS UL	EN GB
Safety class		With built-in safety function P2 (CMJ approval) 10000 AFC (UL)	S0
Rated voltage (50/60 Hz) *2		370 V.AC to 450 V.AC	400 V.AC, 450 V.AC
Rated capacitance *2		1.5 μF to 9 μF	
Capacitance tolerance		-5 %/+10 %, ±5 % (Refer to the individual drawing)	
Withstand voltage	Between terminals	Rated voltage × 1.75, 60 s	Rated voltage × 2.0, 60 s
	Between terminals to enclosure	(min. 2000 V) Rated voltage × 2.0+1000 (V), 60 s	
Maximum permissible temperature (Case wall)		70 °C (Including self temperature rising)	

*1 The range of approval is different depending on each approval.

*2 These are typical values.

Dimension (Example)^{*3}

- SQ series (Mounting type) * Non Mounting type is available. (SP series).

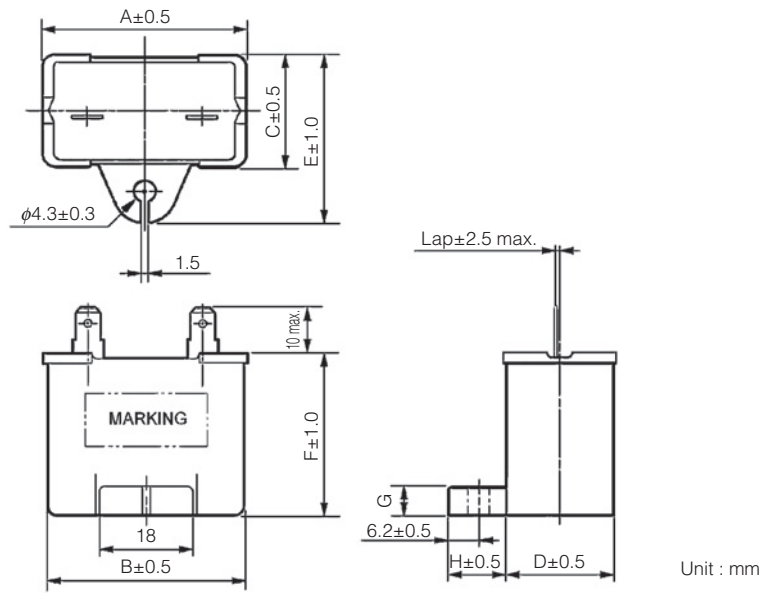

- T series (Printed circuit board (PCB))

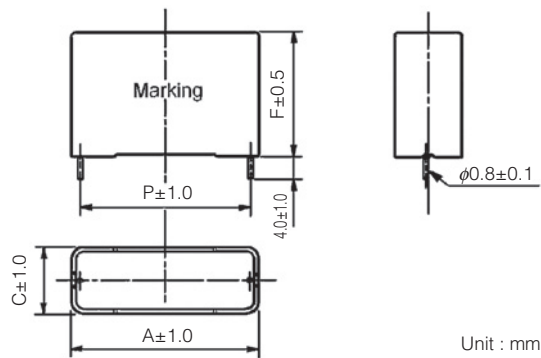

- Terminal shape (Standard)

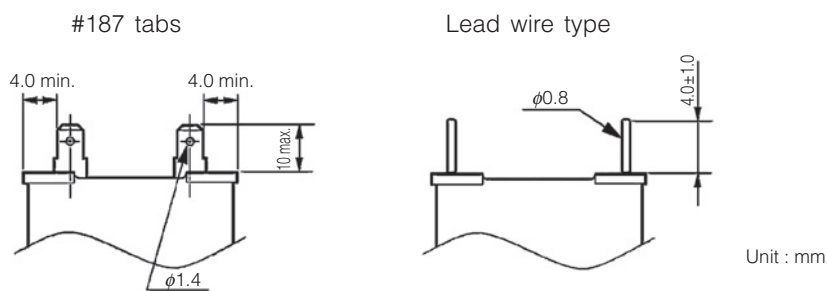

^{*3} Other shape and specific requirement can be designed. Please contact, if necessary.

Rating · Dimensions*4

● SQ series (Installation leg type)

Rated voltage (V.AC)	Capacitance (μ F)	Dimensions (mm)								Case series
		A	B	C	D	E	F	G	H	
400	1.5 to 3.0	39.5	38.0	16.0	14.5	26.5	30.5	4.0	11.0	SQ
	3.5	39.5	38.0	17.5	16.0	28.0	30.5			
	4.0 to 5.0	39.5	38.0	22.0	20.5	32.5	30.5			
	5.5 to 6.5	39.5	38.0	26.7	25.2	37.0	32.0			
	7.0 to 8.0	39.5	38.0	26.7	25.2	37.0	37.0			
	8.5 to 9.0	39.5	38.0	26.7	25.2	37.0	41.0			
450	1.5 to 2.5	39.5	38.0	16.0	14.5	26.5	30.5	4.0	11.0	
	3.0	39.5	38.0	17.5	16.0	28.0	30.5			
	3.5 to 4.0	39.5	38.0	22.0	20.5	32.5	30.5			
	4.5 to 5.5	39.5	38.0	26.7	25.2	37.0	32.0			
	6.0 to 6.5	39.5	38.0	26.7	25.2	37.0	37.0			
	7.0 to 7.5	39.5	38.0	26.7	25.2	37.0	41.0			

● T series (Printed circuit board (PCB))

Rated voltage (V.AC)	Capacitance (μ F)	Dimensions (mm)				Case series
		A	C	F	P	
400	1.5 to 2.5	38.5	14.0	25.5	36.0	T
	3.0 to 3.5	38.5	15.5	29.0	36.0	
	4.0 to 5.0	38.5	20.5	29.0	36.0	
	5.5 to 7.5	38.5	25.0	34.0	36.0	
450	1.5 to 2.0	38.5	14.0	25.5	36.0	
	2.5 to 3.0	38.5	15.5	29.0	36.0	
	3.5 to 4.0	38.5	20.5	29.0	36.0	
	4.5 to 6.5	38.5	25.0	34.0	36.0	

*4 Please contact if necessary other Voltage and Capacitance.

Metalized Polyester Film Capacitor for Noise suppression of Automobile

Series : **ECQE**

Non-inductive construction using metallized polyester film with flame retardant epoxy resin

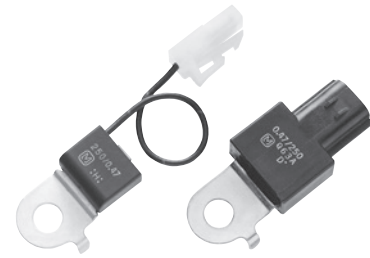

Features

- Excellent water-proof and corrosion-proof construction properties.
- Guaranteed operation temperature of 130 °C max
- Available with wide variety of terminals, including blacket and lead wire
- RoHS directive compliant

Recommended applications

- Noise suppression for automobile

Explanation of part number

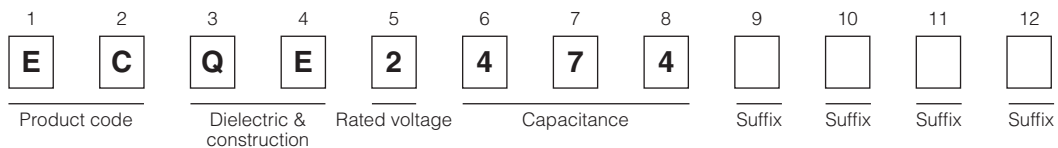

Applicable standard

Category temperature range (Including temperature-rise on unit surface)	-40 °C to +130 °C (Except cord, connector, tube and tape)
Rated voltage *	250 V.DC (Derating of rated voltage by 1.11 %/°C at more than 85 °C)
Rated capacitance *	0.47 μF, 2.2 μF, 4.7 μF
Capacitance tolerance	±20 % (M)
Dissipation factor (tan δ)	tan δ ≤ 1.0 % (20 °C, 1 kHz)
Withstand voltage	250 V.DC × 150 % for 60 s
Insulation resistance (IR)	IR ≥ 3000 MΩ · μF (20 °C, 100 V.DC, 60 s)

Dimensions (Example)

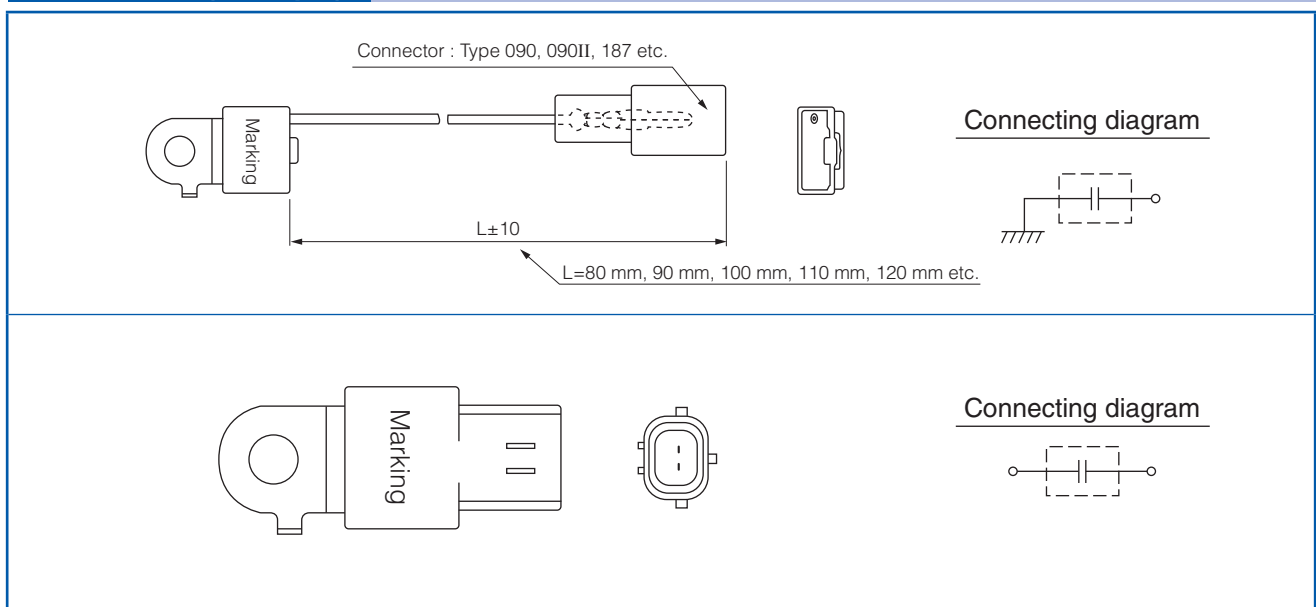

* Other voltage ratings, capacitance values and special dimensions are available upon request. Please consult engineering section.

UPGRADE

Metallized Polypropylene Film Capacitor (For Automotive)

ECWFG series

Non-inductive construction using metallized polypropylene film with flame retardant plastic case.



Features

- High safety (with safety function)
- High moisture resistance (85°C, 85%)
 - 630 V.DC : 500 V.DC, 1000 h
 - 1100 V.DC : 700 V.DC, 500 h (C < 2.0 μF) / 770 V.DC, 500 h (C ≥ 2.0 μF)
- High thermal shock resistance (630, 1100 V.DC : -55°C ⇔ 85°C, 1000 cycles)
- High temperature load test (125°C)
 - 630 V.DC : 450 V.DC, 1000 h
 - 1100 V.DC : 660 V.DC, 1000 h
- Flame-retardant plastic case and non-combustible resin
- AEC-Q200 compliant
- RoHS compliant

Recommended applications

- DC/DC, AC/DC converter circuit in xEV
- High frequency and high current circuits

Explanation of part number

■ Lead pitch : 22.5 mm

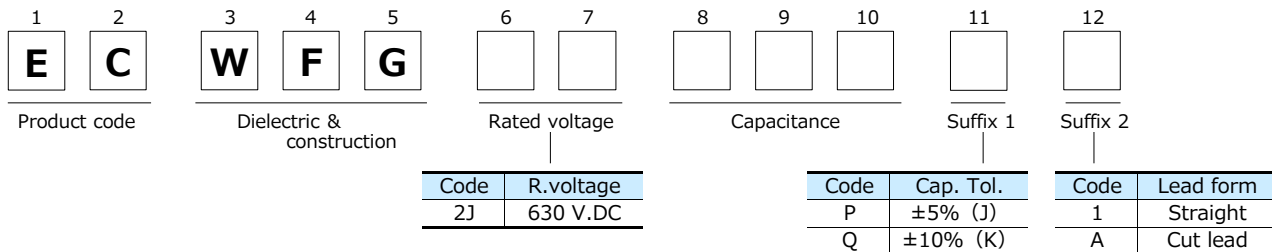

■ Lead pitch : 27.5 mm

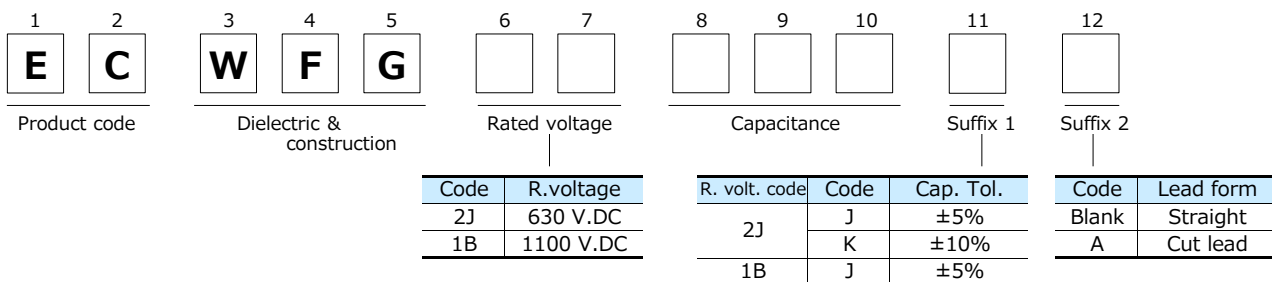

Specifications

Category temp. range (Including temperature-rise on unit surface)	-40 °C to +110 °C		
Rated voltage	630 V.DC, 1100 V.DC (Derating of rated voltage by 1.0 % / °C at more than 85 °C)		
Capacitance range	630 V.DC	Lead pitch : 22.5 mm	1.0 μF, 1.5 μF, 2.2 μF, 3.0 μF
		Lead pitch : 27.5 mm	1.0 μF, 1.5 μF, 2.2 μF, 3.0 μF, 4.7 μF
	1100 V.DC	Lead pitch : 27.5 mm	1.0 μF to 5.0 μF
Capacitance tolerance	±5% (J), ±10% (K)		
Dissipation factor (tan δ)	tan δ ≤ 0.1 % (20 °C, 1 kHz)		
Withstand voltage	Between terminals : Rated voltage (V.DC) × 150 % 60 s		
Insulation resistance (IR)	IR ≥ 3,000 MΩ·uF (20 °C, 500 V.DC, 60 s)		

* In case of applying voltage in alternating current (50 Hz or 60 Hz sine wave) to a capacitor with DC rated voltage, please refer to the page of "Permissible voltage (R.M.S) in alternating current corresponding to DC rated voltage".

Dimensions

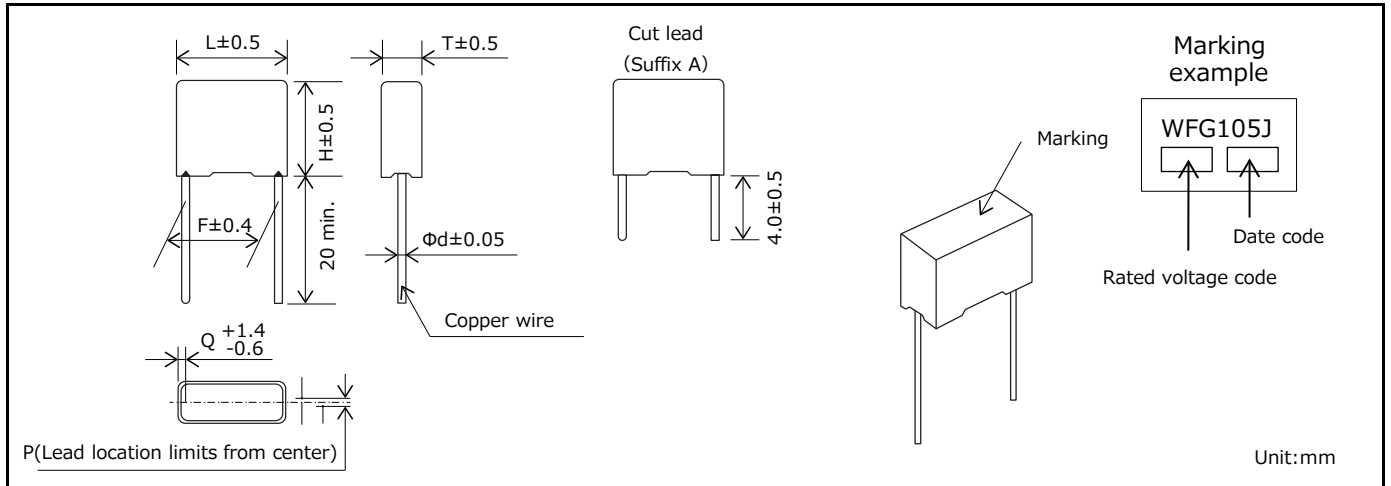

Rating · Dimensions · Quantity

■ Rated voltage : 630 V.DC, Capacitance tolerance : ±5 % (J), ±10 % (K)
 [Lead pitch : 22.5 mm]

Part No	Cap. (μF)	Dimensions (mm)							Min. order Q'ty (PCS)	
		L	T	H	F	Φd	P	Q	Straight	Cut lead
		ECWFG2J105P()	1.0	27.0	10.5	19.0	22.5	1.0		
ECWFG2J105Q()	300	300								
ECWFG2J155P()	1.5	27.0	12.0	21.0	22.5	1.0	0±0.8	2.25	300	300
ECWFG2J155Q()									200	250
ECWFG2J225P()	2.2	27.0	15.5	24.0	22.5	1.0	0±0.8	2.25	200	250
ECWFG2J225Q()									150	150
ECWFG2J305P()	3.0	27.0	17.5	26.5	22.5	1.0	0±0.8	2.25	150	150
ECWFG2J305Q()										

* () : Suffix for lead crimped

[Lead pitch : 27.5 mm]

Part No	Cap. (μF)	Dimensions (mm)							Min. order Q'ty (PCS)	
		L	T	H	F	Φd	P	Q	Straight	Cut lead
		ECWFG2J105□()	1.0	31.5	9.5	18.0	27.5	1.0		
ECWFG2J155□()	1.5	31.5	10.5	21.0	27.5	1.0	0±0.8	2.0	300	300
ECWFG2J225□()	2.2	31.5	12.0	24.5	27.5	1.0	0±0.8	2.0	200	250
ECWFG2J305□()	3.0	31.5	13.5	28.5	27.5	1.0	0±0.8	2.0	150	150
ECWFG2J475□()	4.7	31.5	17.5	32.5	27.5	1.0	0±0.8	2.0	100	100

* □ : Capacitance tolerance code

* () : Suffix for lead crimped

■ Rated voltage : 1100 V.DC, Capacitance tolerance : ±5 % (J)

NEW Part No	Cap. (μF)	Dimensions (mm)							Min. order Q'ty (PCS)	
		L	T	H	F	Φd	P	Q	Straight	Cut lead
		ECWFG1B105J()	1.0	31.5	10.5	21.0	27.5	0.8		
ECWFG1B155J()	1.5	31.5	12.0	24.5	27.5	0.8	0±1.0	2.0	200	250
ECWFG1B205J()	2.0	31.5	12.0	24.5	27.5	0.8	0±1.0	2.0		
ECWFG1B225J()	2.2	31.5	13.5	28.5	27.5	0.8	0±1.0	2.0	150	150
ECWFG1B305J()	3.0	31.5	16.0	29.5	27.5	0.8	0±1.0	2.0		
ECWFG1B335J()	3.3	31.5	16.0	29.5	27.5	0.8	0±1.0	2.0		
ECWFG1B405J()	4.0	31.5	17.5	32.5	27.5	0.8	0±1.0	2.0	100	100
ECWFG1B475J()	4.7	31.5	18.5	35.0	27.5	0.8	0±1.0	2.0		
ECWFG1B505J()	5.0	31.5	18.5	35.0	27.5	0.8	0±1.0	2.0		

* () : Suffix for lead crimped

Metalized Polypropylene Film Capacitor (For Automotive)

ECQUA series [Class X2]

In accordance with UL/CSA and European safety regulation class X2 equipped with a safety mechanism.



Features

- High safety (safety function installed)
- High humidity resistance (THB test : 85 °C, 85 %, 240 V.AC, 1000 h)
- High Thermal shock resistance (-40 ⇔ 85°C, 1000 cycles)
- Flame-retardant plastic case and non-combustible resin
- AEC-Q200 compliant
- RoHS compliant

Recommended applications

- Interference suppressors for automotive

Explanation of part number

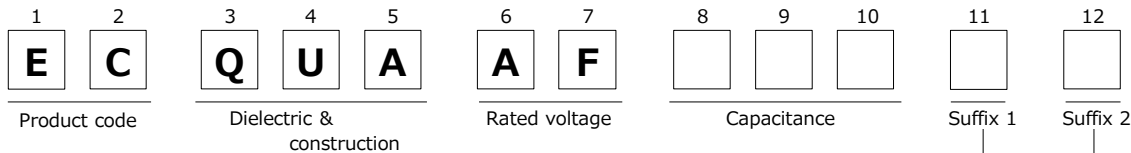

Code	Cap. Tol.	Code	Lead form
T	±10% (K)	1	Straight
S	±20% (M)	A	Cut lead

Applicable standard

* It is certified as type ECQUA in the following approval.

Approval		Class	Certification organization
UL	UL60384-14	Class X2	UL
CSA	CAN/CSA E60384-14	Class X2	
Europe	EN60384-14	Class X2	VDE
International	IEC60384-14	Class X2	

* When applying this capacitor to European and American safety standards, please use type designation and rating such as ECQUA, 0.1 μF.

* Approval number (File No.) of safety regulations are subject to revision without notice. Ask factory for a copy of the latest file No.

Specifications

Category temp. range	-40 °C to +110 °C
Rated voltage	275 V.AC
Capacitance range	0.10 μF to 4.7 μF
Capacitance tolerance	±10 % (K), ±20 % (M)
Dissipation factor (tan δ)	C ≤ 1.0 μF : tan δ ≤ 0.1 % (20 °C, 1 kHz) C > 1.0 μF : tan δ ≤ 0.2 % (20 °C, 1 kHz)
Withstand voltage	Between terminals : 633 V.AC, 1183 V.DC, 60 s Between terminals to enclosure : 2050 V.AC, 60 s
Insulation resistance (IR)	C ≤ 0.33 μF : IR ≥ 15,000 MΩ (20 °C, 100 V.DC, 60 s) C > 0.33 μF : IR ≥ 5,000 MΩ · μF (20 °C, 100 V.DC, 60 s) C ≤ 0.47 μF : IR ≥ 2,000 MΩ (20 °C, 500 V.DC, 60 s)
Maximum AC voltage * *	310 V.AC

* Use of this capacitor is limited to AC voltage (50 Hz or 60 Hz sine wave).

* A faint corona discharge may occur inside of the capacitor element at rated voltage, however there is no influence on the reliability of the capacitor.

* * Maximum AC voltage including line voltage fluctuation is 310 V.AC.

310 V.AC is not nominal continuous applied voltage, but only indicates maximum value including in the voltage of the power supply.

Basic nominal voltage is considered as 240 V.AC.

This maximum AC voltage is specified in only ECQUA type, not specified in other types.

Please refer to individual product specification, and contact us for further questions regarding design life.

Dimensions

$L \pm 0.5$, $T \pm 0.5$, $H \pm 0.5$, $F \pm 0.4$, 20 min. , $\Phi d \pm 0.05$, 4.0 ± 0.5 , $Q \begin{smallmatrix} +1.4 \\ -0.6 \end{smallmatrix}$, P (Lead location limits from center)

Solder-plated copper wire or Solder-plated copper-clad steel wire

Cut lead (Suffix A)

Marking example

(A) side	(B) or (C) side

Note : Only $\pm 10\%$ as cap. tol. Be marked as "K".
 Note: Date code.

Unit: mm

Rating · Dimensions · Quantity

Part No.	Cap. (μF)	Dimensions (mm)							Min. order Q'ty (PCS)			
		L	T	H	F	Φd	P	Q	Straight			
									Cut lead			
ECQUAAF104T ()	0.10	17.5	5.0	12.0	15.0	0.6	0±0.8	1.3	1000	1000		
ECQUAAF104S ()												
ECQUAAF154T ()	0.15	17.5	6.0	13.0	15.0	0.6	0±0.8	1.3			800	
ECQUAAF154S ()												
ECQUAAF224T ()	0.22	17.5	7.5	14.0	15.0	0.6	0±0.8	1.3				600
ECQUAAF224S ()												
ECQUAAF334T ()	0.33	17.5	9.0	16.0	15.0	0.6	0±0.8	1.3	500			
ECQUAAF334S ()												
ECQUAAF474T ()	0.47	26.0	8.5	15.0	22.5	0.8	0±0.8	1.8		500		
ECQUAAF474S ()												
ECQUAAF684T ()	0.68	26.0	10.0	17.0	22.5	0.8	0±0.8	1.8			300	
ECQUAAF684S ()												
ECQUAAF105T ()	1.0	26.0	12.0	19.0	22.5	0.8	0±0.8	1.8	200			
ECQUAAF105S ()												
ECQUAAF155T ()	1.5	31.0	12.0	22.0	27.5	0.8	0±0.8	1.8		150		
ECQUAAF155S ()												
ECQUAAF225T ()	2.2	31.0	14.5	24.5	27.5	0.8	0±0.8	1.8			100	
ECQUAAF225S ()												
ECQUAAF335T ()	3.3	31.0	19.0	29.0	27.5	0.8	0±0.8	1.8	100			
ECQUAAF335S ()												
ECQUAAF475T ()	4.7	31.0	23.0	33.0	27.5	0.8	0±0.8	1.8				
ECQUAAF475S ()												

* () : Suffix for lead crimped

DC-Link Film Capacitor

Series : **TYPE1**

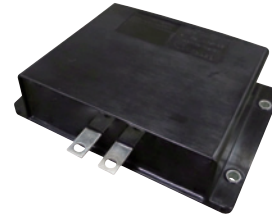

Features

- High safety, Self-healing and Self-protecting function built in.
- No catastrophic failure upon natural end of life due to inbuilt fuse function.
- Open circuit failure mode by fuse function patterned electrode
- Can replace Electrolytic Capacitor
- Low ESR, High Ripple Current capability
- Low ESL
- RoHS directive compliant

Recommended applications

- Any automotive and/or other application requiring DC Linkage
- * Verify the usage and fitting environments, and make sure to observe the rated performance specified in the corresponding specifications.

Construction

- Dielectric : Polypropylene
- Electrode : Metallized dielectric with Segment pattern
- Plastic Case : PPS. equivalent to UL94 V-0
- Sealing : Epoxy Resin equivalent to UL94 HB
- Terminal : Copper with Tin plating

Explanation of part number

1	2	3	4	5	6	7	8	9	10	11	12
E	Z	T	V	K	C	T	Y	P	1	H	A

Specifications

Operating temperature on the surface of the case	- 40 °C to +105 °C including self heat generation
Capacitance	581 μF ^{+10%} / _{-5%} at 1 kHz, 25 °C
Rated voltage	450 V.DC
Maximum voltage	600 V.DC for 60 sec in life time
Rated ripple current	Continuous 80 Arms at 10 kHz
Current derating	Refer Fig.1
ESR	0.8 mΩ or less at 10KHz
ESL	20 nH or less at 1MHz
Insulation Resistance between Terminals and Case	1 GΩ or more Measure after applying 500 V.DC for 2 seconds.
Dimensions L × W × H (Typical data)	164 × 115 × 43.1 mm : Excluding terminals
Weight (Typical data)	980 g

Note:

1) Voltage includes ripple voltage

2) Derate the current when the maximum surface temperature exceeds 95 degC, as shown in Fig. 1.

Characteristics <Reference>

<Temperature characteristics (Typical curve)>

● Change of capacitance

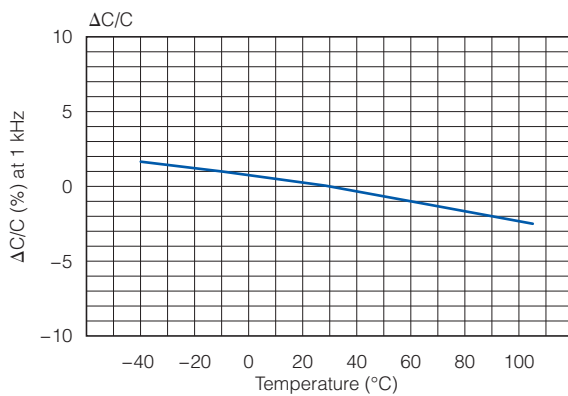

● Equivalent series resistance

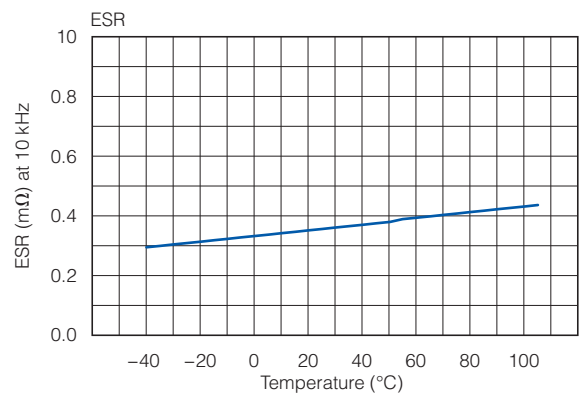

<Frequency characteristics (Typical curve)>

● Equivalent series resistance

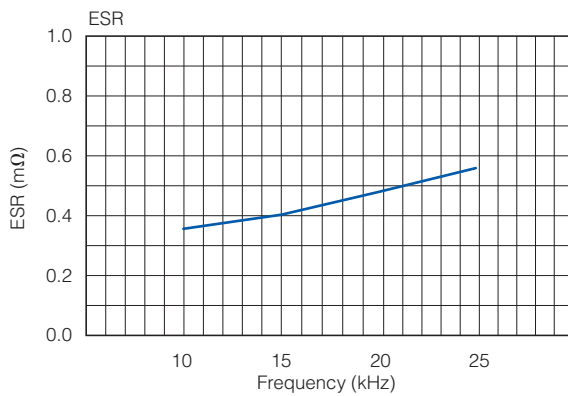

<Lifetime Expectancy (Reference)>

* Expected life : 15,000 hours

* Failure in Time : 300 Fits

The above values are reference calculated under an pre-assumed average operating condition.

Metalized Polypropylene Film Capacitor

Series : **EZPE Series**

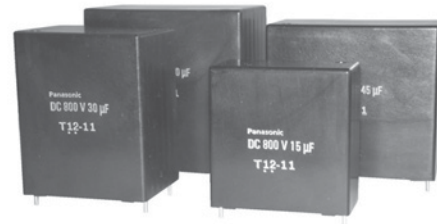

Features

- High safety, Self-healing and Self-protecting function built-in
- Long product life, High reliability
- Low loss, Low ESR
- Flame retardant (Case and sealing resin)
- RoHS directive compliant

Recommended applications

For DC filtering, DC link circuit

- Solar inverters
- Wind power generation
- Industrial power supplies
- Inverter circuit in appliances (Air Conditioners etc.)

Construction

- Dielectric : Polypropylene film
- Electrodes : Metallized dielectric with segmented pattern
- Plastic case : UL94 V-0
- Sealing : UL94 V-0
- Terminals : Tinned wires, 2-pin and 4-pin versions

Explanation of part number

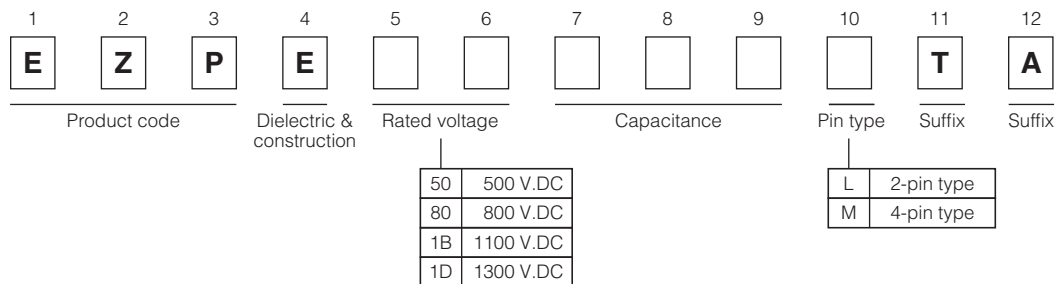

Specifications

Category temperature range (T _C) *1	-40 °C to +85 °C	
Rated voltage(V _R) *2	500 V.DC, 800 V.DC, 1100 V.DC, 1300 V.DC (Derating of rated voltage by more than 70 °C *3)	
Rated capacitance (C _R)	500 V.DC	10 µF to 110 µF
	800 V.DC	10 µF to 60 µF
	1100 V.DC	10 µF to 40 µF
	1300 V.DC	10 µF to 25 µF
Capacitance tolerance	±10 %	
Withstanding DC voltage	Between terminals : Rated voltage. (V.DC)×150 %, 10 s Terminal to case : 2110 V.AC (50 Hz or 60 Hz), 10 s	
Insulation resistance (CR)	CR ≥ 10000 Ω · F (20 °C, 500 V.DC, 60 s)	

*1 : The temperature of capacitor surface (case)

*2 : Use for DC voltage only

*3 : Refer to the page of "DC voltage derating"

Dimensions

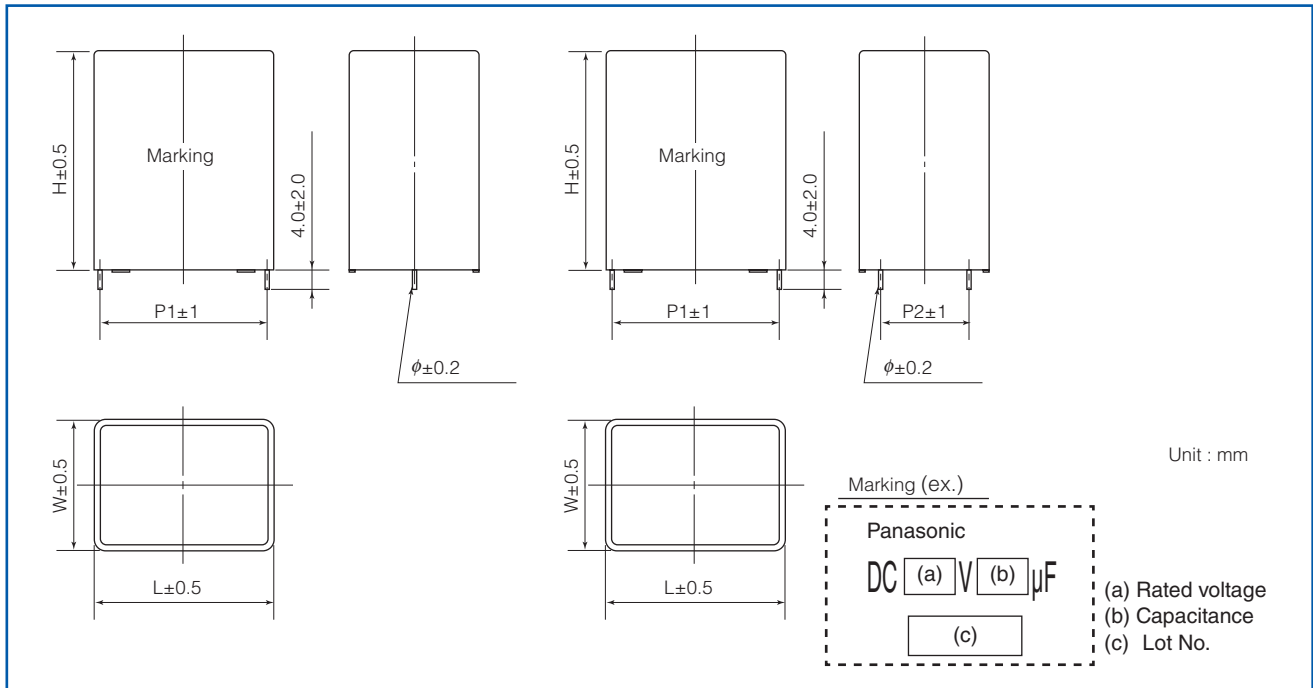

Rating · Dimensions · Quantity

- Rated voltage : 500 V.DC at 70 °C (450 V.DC at 85 °C)

Part No.	Cap. C_R (μ F)	Dimensions (mm)						dv/dt [V/ μ s]	Permissible current		ESR _{typ} ^{*3} (m Ω)	tan δ ^{*4} (%)	Mass (g)	Min. order Q'ty ^{*5} (pcs)
		W	H	L	P1	P2	ϕ		Peak Current ^{*1} (A _{o-p})	RMS Current ^{*2} (A _{rms})				
EZPE50106LTA	10	20	42	41.5	37.5	-	1.2	21	210	5.0	22.0	0.28	45	600
EZPE50156LTA	15	20	42	41.5	37.5	-	1.2	21	315	7.5	14.8	0.28	45	
EZPE50206LTA	20	20	42	41.5	37.5	-	1.2	21	420	9.5	11.0	0.28	44	
EZPE50256LTA	25	20	42	41.5	37.5	-	1.2	21	525	11.0	8.8	0.28	43	
EZPE50306MTA	30	20	42	41.5	37.5	10.2	1.2	21	630	12.5	7.0	0.28	43	
EZPE50356MTA	35	30	51	41.5	37.5	10.2	1.2	21	735	13.5	6.2	0.28	83	400
EZPE50406MTA	40	30	51	41.5	37.5	10.2	1.2	21	840	14.5	5.4	0.28	82	
EZPE50456MTA	45	30	51	41.5	37.5	10.2	1.2	21	945	15.2	4.9	0.28	81	
EZPE50506MTA	50	30	51	41.5	37.5	20.3	1.2	21	1050	16.0	4.4	0.28	80	
EZPE50556MTA	55	30	51	41.5	37.5	20.3	1.2	21	1155	16.3	4.1	0.28	79	
EZPE50606MTA	60	30	51	41.5	37.5	20.3	1.2	21	1260	16.5	3.9	0.28	77	200
EZPE50656MTA	65	30	51	57.5	52.5	10.2	1.2	14	910	15.0	6.8	0.44	111	
EZPE50706MTA	70	30	51	57.5	52.5	10.2	1.2	14	980	15.5	6.5	0.44	109	
EZPE50756MTA	75	30	51	57.5	52.5	20.3	1.2	14	1050	16.0	6.0	0.44	108	
EZPE50806MTA	80	30	51	57.5	52.5	20.3	1.2	14	1120	16.5	5.7	0.44	106	
EZPE50856MTA	85	35	56	57.5	52.5	20.3	1.2	14	1190	16.7	5.4	0.44	142	200
EZPE50906MTA	90	35	56	57.5	52.5	20.3	1.2	14	1260	17.0	5.1	0.44	141	
EZPE50956MTA	95	35	56	57.5	52.5	20.3	1.2	14	1330	17.5	4.9	0.44	140	
EZPE50107MTA	100	35	56	57.5	52.5	20.3	1.2	14	1400	18.0	4.7	0.44	139	
EZPE50117MTA	110	35	56	57.5	52.5	20.3	1.2	14	1540	18.5	4.4	0.44	138	

*1 : When rising temperature of capacitor surface by continuous peak current (included pulse current), use within limit specified for temperature of capacitor surface and self heating temperature rise.

*2 : Maximum RMS current @70 °C, 10 kHz
Use within limit for self heating temperature rise at capacitor surface.

*3 : Typical values @ 20 °C, 10 kHz ESR : less than 2.5×ESR_{typ}

*4 : Maximum dissipation factor @ 20 °C, 1 kHz

*5 : Minimum order quantity consists of 4 packing units.

Rating · Dimensions · Quantity

● Rated voltage : 800 V.DC at 70 °C (700 V.DC at 85 °C)

Part No.	Cap. C _R (μF)	Dimensions (mm)						dv/dt [V/μs]	Permissible current		ESR _{typ} *3 (mΩ)	tan δ *4 (%)	Mass (g)	Min. order Q'ty *5 (pcs)
		W	H	L	P1	P2	φ		Peak Current *1 (A _{o-p})	RMS Current *2 (A _{rms})				
EZPE80106LTA	10	20	42	41.5	37.5	–	1.2	22	220	7	15.8	0.22	44	600
EZPE80156MTA	15	20	42	41.5	37.5	10.2	1.2	22	330	9	10.5	0.22	43	
EZPE80206MTA	20	30	51	41.5	37.5	10.2	1.2	22	440	11	7.7	0.22	82	400
EZPE80256MTA	25	30	51	41.5	37.5	10.2	1.2	22	550	13	6.8	0.22	80	
EZPE80306MTA	30	30	51	41.5	37.5	20.3	1.2	22	660	15	5.3	0.22	78	200
EZPE80356MTA	35	30	51	57.5	52.5	10.2	1.2	15	525	12	9.7	0.33	110	
EZPE80406MTA	40	30	51	57.5	52.5	20.3	1.2	15	600	13	8.3	0.33	107	
EZPE80456MTA	45	30	51	57.5	52.5	20.3	1.2	15	675	14	7.0	0.33	104	
EZPE80506MTA	50	35	56	57.5	52.5	20.3	1.2	15	750	15	6.3	0.33	140	
EZPE80556MTA	55	35	56	57.5	52.5	20.3	1.2	15	825	16	5.9	0.33	138	
EZPE80606MTA	60	35	56	57.5	52.5	20.3	1.2	15	900	17	5.6	0.33	136	

● Rated voltage : 1100 V.DC at 70 °C (920 V.DC at 85 °C)

Part No.	Cap. C _R (μF)	Dimensions (mm)						dv/dt [V/μs]	Permissible current		ESR _{typ} *3 (mΩ)	tan δ *4 (%)	Mass (g)	Min. order Q'ty *5 (pcs)
		W	H	L	P1	P2	φ		Peak Current *1 (A _{o-p})	RMS Current *2 (A _{rms})				
EZPE1B106MTA	10	20	42	41.5	37.5	10.2	1.2	54	540	7.0	12.3	0.20	43	600
EZPE1B156MTA	15	30	51	41.5	37.5	10.2	1.2	54	810	8.5	8.2	0.20	80	
EZPE1B206MTA	20	30	51	41.5	37.5	20.3	1.2	54	1080	10.0	6.3	0.20	76	400
EZPE1B256MTA	25	30	51	57.5	52.5	10.2	1.2	35	875	8.0	10.7	0.28	107	
EZPE1B306MTA	30	30	51	57.5	52.5	20.3	1.2	35	1050	9.0	8.5	0.28	103	200
EZPE1B356MTA	35	35	56	57.5	52.5	20.3	1.2	35	1225	10.0	7.2	0.28	137	
EZPE1B406MTA	40	35	56	57.5	52.5	20.3	1.2	35	1400	11.0	6.5	0.28	134	

● Rated voltage : 1300 V.DC at 70 °C (1100 V.DC at 85 °C)

Part No.	Cap. C _R (μF)	Dimensions (mm)						dv/dt [V/μs]	Permissible current		ESR _{typ} *3 (mΩ)	tan δ *4 (%)	Mass (g)	Min. order Q'ty *5 (pcs)
		W	H	L	P1	P2	φ		Peak Current *1 (A _{o-p})	RMS Current *2 (A _{rms})				
EZPE1D106MTA	10	30	51	41.5	37.5	10.2	1.2	73	730	12.0	10.0	0.17	80	400
EZPE1D156MTA	15	30	51	57.5	52.5	10.2	1.2	50	750	10.0	14.5	0.22	109	200
EZPE1D206MTA	20	30	51	57.5	52.5	20.3	1.2	50	1000	14.0	11.1	0.22	103	
EZPE1D256MTA	25	35	56	57.5	52.5	20.3	1.2	50	1250	17.0	8.5	0.22	136	

*1 : When rising temperature of capacitor surface by continuous peak current (included pulse current), use within limit specified for temperature of capacitor surface and self heating temperature rise.

*2 : Maximum RMS current @70 °C, 10 kHz
Use within limit for self heating temperature rise at capacitor surface.

*3 : Typical values @ 20 °C, 10 kHz ESR : less than 2.5×ESR_{typ}

*4 : Maximum dissipation factor @ 20 °C, 1 kHz

*5 : Minimum order quantity consists of 4 packing units.

Metallized Polypropylene Film Capacitor

Series : **EZPE Series (Low profile type)**



Features

- High safety, Self-healing and Self-protecting function built-in
- Long product life, High reliability, High moisture resistance
- Low loss, Low ESR
- Flame retardant
- Low profile design
- RoHS directive compliant

Recommended applications

For DC filtering, DC link circuit

- Solar inverters, Micro inverters
- Wind power generation
- Industrial power supplies
- Inverter circuit in appliances (Air Conditioners etc.)

Construction

- Dielectric : Polypropylene film
- Electrodes : Metallized dielectric with segmented pattern
- Plastic case : UL94 V-0
- Sealing : UL94 V-0
- Terminals : Tinned wires, 2-pin and 4-pin versions

Explanation of part number

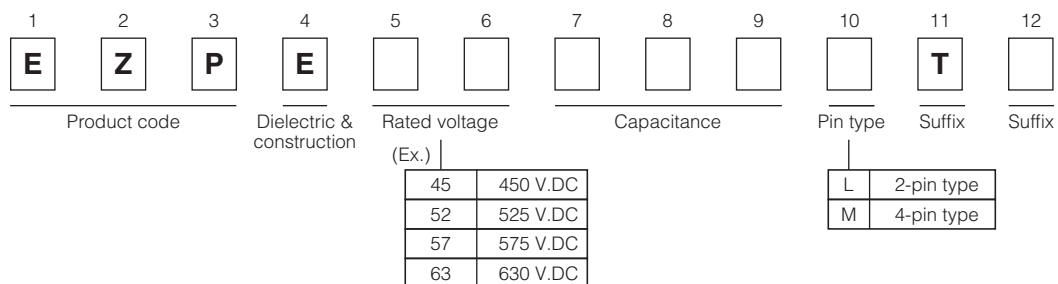

Specifications

Category temperature range (T _C) *1	-40 °C to +85 °C	
Rated voltage(V _R) *2	450 V.DC, 525 V.DC, 575 V.DC, 630 V.DC (Derating of rated voltage by more than 70 °C *3)	
Rated capacitance (C _R)	450 V.DC	66 μF
	525 V.DC	29 μF
	575 V.DC	12 μF
	630 V.DC	10 μF
Capacitance tolerance	±15 %	
Withstanding DC voltage	Between terminals : Rated voltage. (V.DC)×150 %, 10 s Terminal to case : 2000 V.AC (50 Hz or 60 Hz), 10 s	
Insulation resistance (CR)	CR ≥ 10000 Ω · F (20 °C, 500 V.DC, 60 s)	

*1 : The temperature of capacitor surface (case)

*2 : Use for DC voltage only

*3 : Refer to the page of "DC voltage derating"

Dimensions

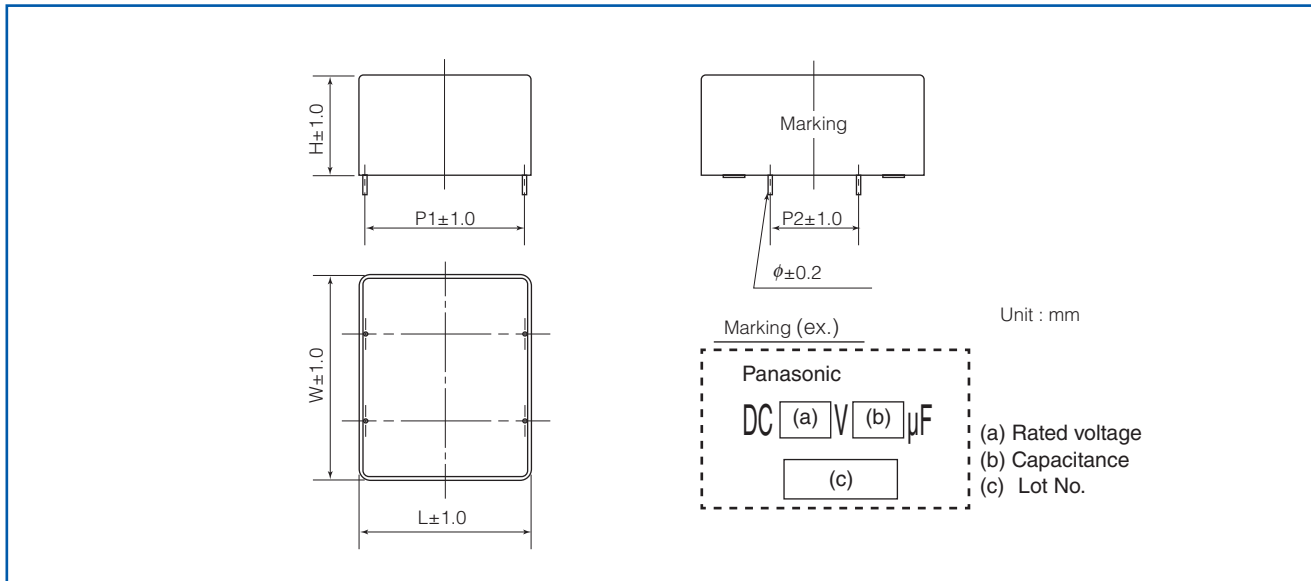

Rating · Dimensions · Quantity

- Rated voltage : 450 V.DC at 70 °C

Part No.	Cap. C_R (μF)	Dimensions (mm)						dv/dt [V/ μs]	Permissible current		ESR _{typ} *3 ($\text{m}\Omega$)	tan δ *4 (%)	Mass (g)	Min. order Q'ty *5 (pcs)
		W	H	L	P1	P2	ϕ		Peak Current *1 (A_{o-p})	RMS Current *2 (A_{rms})				
EZPE45666MTB	66	90	24	32.5	27.5	37.5	0.8	5	300	15.0	5.0	0.3	110	200

- Rated voltage : 525 V.DC at 70 °C

Part No.	Cap. C_R (μF)	Dimensions (mm)						dv/dt [V/ μs]	Permissible current		ESR _{typ} *3 ($\text{m}\Omega$)	tan δ *4 (%)	Mass (g)	Min. order Q'ty *5 (pcs)
		W	H	L	P1	P2	ϕ		Peak Current *1 (A_{o-p})	RMS Current *2 (A_{rms})				
EZPE52296MTB	29	48.5	23.5	37.0	34.0	20.3	0.8	14	400	3.0	7.0	0.4	50	400

- Rated voltage : 575 V.DC at 70 °C

Part No.	Cap. C_R (μF)	Dimensions (mm)						dv/dt [V/ μs]	Permissible current		ESR _{typ} *3 ($\text{m}\Omega$)	tan δ *4 (%)	Mass (g)	Min. order Q'ty *5 (pcs)
		W	H	L	P1	P2	ϕ		Peak Current *1 (A_{o-p})	RMS Current *2 (A_{rms})				
EZPE57126LTB	12	24.5	19.5	41.5	37.5	-	1.0	22	264	5.0	22.0	0.45	25	800

- Rated voltage : 630 V.DC at 70 °C

Part No.	Cap. C_R (μF)	Dimensions (mm)						dv/dt [V/ μs]	Permissible current		ESR _{typ} *3 ($\text{m}\Omega$)	tan δ *4 (%)	Mass (g)	Min. order Q'ty *5 (pcs)
		W	H	L	P1	P2	ϕ		Peak Current *1 (A_{o-p})	RMS Current *2 (A_{rms})				
EZPE63106LTB	10	24.5	19.5	41.5	37.5	-	1.0	21	210	3.0	22.0	0.45	25	800

*1 : When rising temperature of capacitor surface by continuous peak current (included pulse current), use within limit specified for temperature of capacitor surface and self heating temperature rise.

*2 : Maximum RMS current @ 70 °C, 10 kHz
Use within limit for self heating temperature rise at capacitor surface.

*3 : Typical values @ 20 °C, 10 kHz ESR : less than $2.5 \times \text{ESR}_{\text{typ}}$

*4 : Maximum dissipation factor @ 20 °C, 1 kHz

*5 : Minimum order quantity consists of 4 packing units.

UPGRADE

Metallized Polypropylene Film Capacitor

EZPQ series



Features

- High safety (Self-protecting function built-in)
- Long product life, High reliability
- Low loss, Low ESR
- Flame retardant (Case and sealing resin)
- High moisture resistance (85 °C, 85 %RH)
 - 330 V.AC : 280 V.AC, 1000 h
 - 380 V.AC : 320 V.AC, 1000 h
- RoHS compliant

Recommended applications

For AC filter

- Solar inverters
- UPS
- Industrial power supplies
- Inverter circuit in appliances (Air conditioners etc.)

Construction

- Dielectric : Polypropylene film
- Electrodes : Metallized dielectric with segmented pattern
- Plastic case : UL94 V-0
- Sealing : UL94 V-0
- Terminals : Tinned wires, 2-pin and 4-pin versions

Explanation of part number

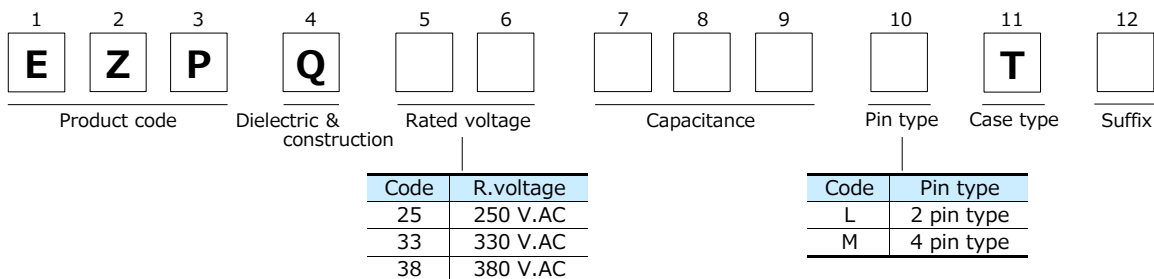

Specifications

Category temperature range *1	250 V.AC	-40 °C to +85 °C
	330 V.AC	-40 °C to +105 °C
	380 V.AC	
Rated voltage *2	250 V.AC	250 V.AC
	330 V.AC, 380 V.AC	(Derating of rated voltage by 1.0 %/°C at more than 85 °C)
Rated capacitance	250 V.AC	12, 22, 36 µF
	330 V.AC	3 µF to 20 µF
	380 V.AC	1 µF to 15 µF
Capacitance tolerance		±5%, ±10 %
Withstand voltage	250 V.AC	Between terminals : Rated voltage (V.AC) × 175 % 10 s Terminal to case : 2000 V.AC (50 Hz or 60 Hz), 10 s
	330 V.AC	Between terminals : Rated voltage (V.AC) × 150 % 60 s Terminal to case : 2000 V.AC (50 Hz or 60 Hz), 10 s
	380 V.AC	
Insulation resistance (IR)		CR ≥ 10,000 Ω·F (20 °C, 100 V.DC, 60 s)

*1 : The temperature of capacitor surface (case).

*2 : Use for AC voltage only.

Dimensions

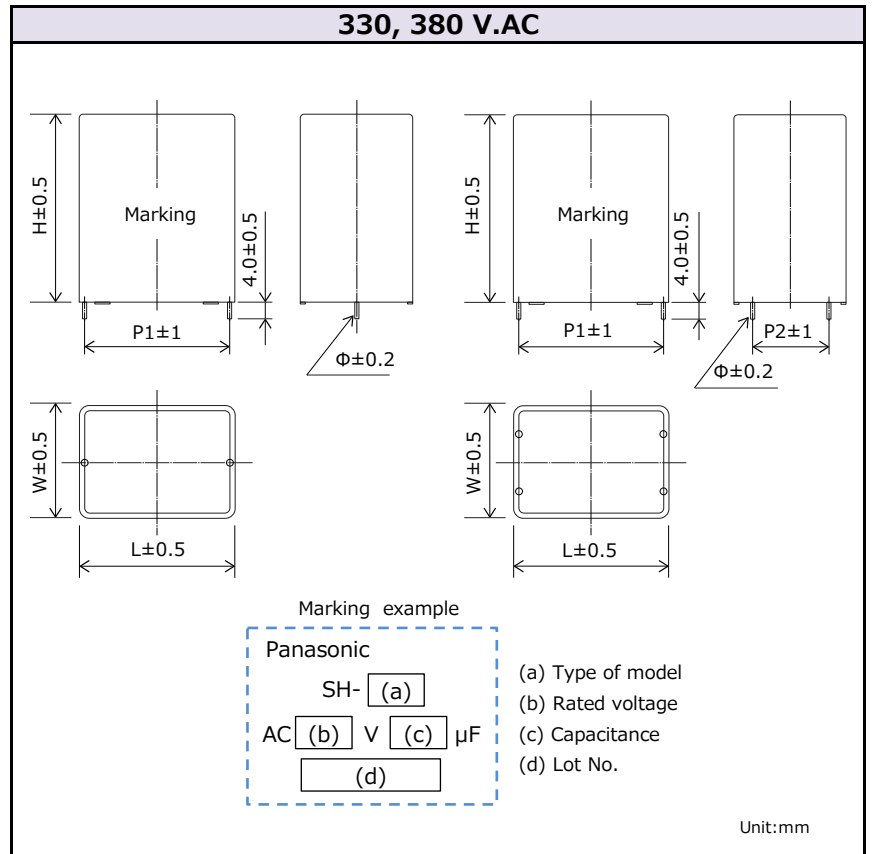
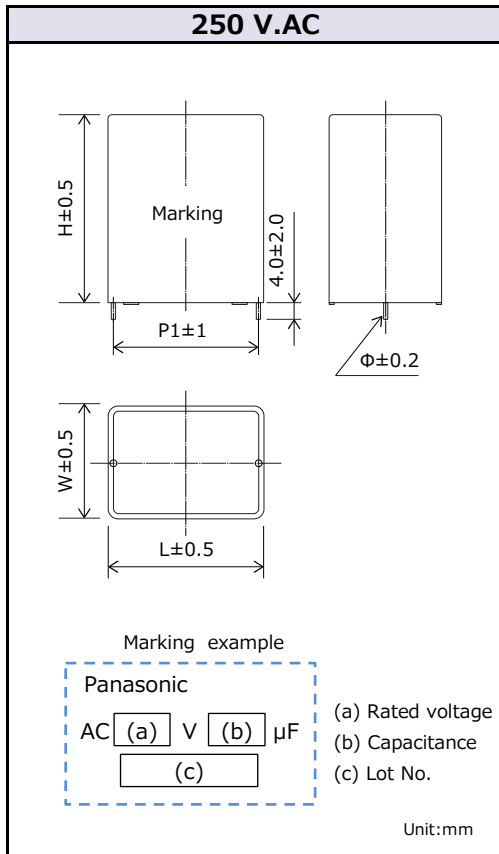

Rating · Dimensions · Quantity

■ Rated voltage : 250 V.AC

Part No.	Capacitance (μF)	Dimensions (mm)						Mass (g)	Min. order Q'ty*1 (PCS)
		W	H	L	P1	P2	Φ		
EZPQ25126LTA	12	22	36	48.5	45.6	—	1.2	80	800
EZPQ25226LTA	22	30	45	57.5	52.5	—	1.2	107	200
EZPQ25366LTA	36	35	56	57.5	52.5	—	1.2	136	200

*1 : Minimum order quantity consists of 4 packing units.

Rating · Dimensions · Quantity

■ Rated voltage : 330 V.AC **NEW**

Part No.	Cap. Tol. (%)	Cap. (μF)	Dimensions (mm)						dv/dt (V/μs)	Permissible current		ESR* ³ (mΩ)	Mass (g)	Min. order Qty* ⁴ (PCS)
			W	H	L	P1	P2	Φ		Peak current* ¹ (A _{0-P})	RMS current* ² (A rms)			
EZPQ33305LTA	±5	3.0	17.0	34.5	41.0	37.5	-	1.0	23	69	5.0	23.0	38	1200
EZPQ33335LTA	±5	3.3	17.0	34.5	41.0	37.5	-	1.0	23	76	5.3	21.2	38	1200
EZPQ33355LTA	±5	3.5	17.0	34.5	41.0	37.5	-	1.0	23	81	5.6	20.0	39	1200
EZPQ33405LTA	±5	4.0	17.0	34.5	41.0	37.5	-	1.0	23	92	6.2	17.5	40	1200
EZPQ33455LTA	±5	4.5	17.0	34.5	41.0	37.5	-	1.0	23	104	6.8	15.9	39	1200
EZPQ33475LTA	±5	4.7	22.0	36.0	41.0	37.5	-	1.0	23	108	6.8	16.2	51	600
EZPQ33505LTA	±5	5.0	22.0	36.0	41.0	37.5	-	1.0	23	115	7.1	15.2	50	600
EZPQ33605LTA	±5	6.0	22.0	36.0	41.0	37.5	-	1.0	23	138	8.0	13.5	58	600
EZPQ33685LTA	±5	6.8	26.0	40.5	41.0	37.5	-	1.0	23	156	8.6	12.6	73	600
EZPQ33705LTA	±5	7.0	26.0	40.5	41.0	37.5	-	1.0	23	161	8.8	12.2	73	600
EZPQ33805LTA	±5	8.0	26.0	40.5	41.0	37.5	-	1.0	23	184	9.5	11.3	74	600
EZPQ33905LTA	±5	9.0	26.5	41.5	41.5	37.5	-	1.0	23	207	10.3	10.6	78	400
EZPQ33106LTB	±5	10.0	30.0	50.5	41.0	37.5	-	1.0	23	230	10.4	10.9	100	400
EZPQ33106LTC	±5	10.0	35.5	50.5	42.5	37.5	-	1.2	23	230	12.1	8.1	115	400
EZPQ33126LTA	±5	12.0	30.0	50.5	41.0	37.5	-	1.0	23	276	11.5	10.0	99	400
EZPQ33146LTA	±5	14.0	35.5	50.5	42.5	37.5	-	1.2	23	322	14.4	7.1	122	400
EZPQ33156LTA	±5	15.0	35.5	50.5	42.5	37.5	-	1.2	23	345	14.9	7.0	143	400
EZPQ33206LTB	±5	20.0	43.0	58.0	41.0	37.5	-	1.2	23	460	17.9	5.9	182	400
EZPQ33106MTA	±5	10.0	30.0	50.5	41.0	37.5	10.2	1.0	23	230	10.4	10.9	101	400
EZPQ33126MTA	±5	12.0	30.0	50.5	41.0	37.5	10.2	1.0	23	276	11.5	10.0	100	400
EZPQ33146MTA	±5	14.0	35.5	50.5	42.5	37.5	10.2	1.2	23	322	14.4	7.1	122	400
EZPQ33156MTA	±5	15.0	35.5	50.5	42.5	37.5	10.2	1.2	23	345	14.9	7.0	144	400
EZPQ33206MTA	±5	20.0	43.0	58.0	41.0	37.5	10.2	1.2	23	460	17.9	5.9	184	400

■ Rated voltage : 380 V.AC **NEW**

Part No.	Cap. Tol. (%)	Cap. (μF)	Dimensions (mm)						dv/dt (V/μs)	Permissible current		ESR* ³ (mΩ)	Mass (g)	Min. order Qty* ⁴ (PCS)
			W	H	L	P1	P2	Φ		Peak current* ¹ (A _{0-P})	RMS current* ² (A rms)			
EZPQ38105LTA	±5	1.0	15.0	29.0	41.0	37.5	-	1.0	50	50	2.1	71.6	27	1200
EZPQ38155LTA	±5	1.5	15.0	29.0	41.0	37.5	-	1.0	50	75	2.8	48.8	28	1200
EZPQ38205LTA	±5	2.0	15.0	29.0	41.0	37.5	-	1.0	50	100	3.5	36.6	29	1200
EZPQ38225LTB	±5	2.2	15.0	29.0	41.0	37.5	-	1.0	50	110	3.8	33.2	30	1200
EZPQ38255LTB	±5	2.5	15.0	29.0	41.0	37.5	-	1.0	50	125	4.1	29.2	31	1200
EZPQ38305LTA	±5	3.0	17.0	34.5	41.0	37.5	-	1.0	50	150	4.8	24.4	39	1200
EZPQ38335LTA	±5	3.3	17.0	34.5	41.0	37.5	-	1.0	50	165	5.2	22.1	38	1200
EZPQ38355LTA	±5	3.5	17.0	34.5	41.0	37.5	-	1.0	50	175	5.4	20.9	39	1200
EZPQ38405LTA	±5	4.0	22.0	36.0	41.0	37.5	-	1.0	50	200	6.0	18.3	50	600
EZPQ38455LTA	±5	4.5	22.0	36.0	41.0	37.5	-	1.0	50	225	6.5	16.7	52	600
EZPQ38475LTA	±5	4.7	22.0	36.0	41.0	37.5	-	1.0	50	235	6.7	16.0	51	600
EZPQ38505LTA	±5	5.0	22.0	36.0	41.0	37.5	-	1.0	50	250	7.1	15.1	59	600
EZPQ38555LTA	±5	5.5	26.0	40.5	41.0	37.5	-	1.0	50	275	7.4	14.4	71	600
EZPQ38605LTA	±5	6.0	26.0	40.5	41.0	37.5	-	1.0	50	300	7.8	13.7	73	600
EZPQ38705LTA	±5	7.0	26.0	40.5	41.0	37.5	-	1.0	50	350	8.7	12.2	74	600
EZPQ38755LTA	±5	7.5	26.5	41.5	41.5	37.5	-	1.0	50	375	9.1	11.8	78	400
EZPQ38805LTC	±10	8.0	26.5	41.5	41.5	37.5	-	1.0	70	560	10.0	6.0	78	400
EZPQ38805LTD	±5	8.0	27.5	42.0	41.5	37.5	-	1.0	50	400	9.2	11.9	80	600
EZPQ38855LTA	±5	8.5	30.0	50.5	41.0	37.5	-	1.0	50	425	9.5	11.7	101	400
EZPQ38905LTA	±5	9.0	30.0	50.5	41.0	37.5	-	1.0	50	450	9.8	11.4	100	400
EZPQ38955LTA	±5	9.5	30.0	50.5	41.0	37.5	-	1.0	50	475	10.1	11.0	100	400
EZPQ38106LTA	±5	10.0	30.0	50.5	41.0	37.5	-	1.0	50	500	10.4	10.8	100	400
EZPQ38126LTA	±5	12.0	30.0	56.0	41.5	37.5	-	1.2	50	600	12.7	8.0	122	400
EZPQ38156LTA	±5	15.0	38.0	57.5	42.0	37.5	-	1.2	50	750	14.6	7.1	157	400
EZPQ38805MTA	±5	8.0	27.5	42.0	41.5	37.5	10.2	1.0	50	400	9.2	11.9	81	600
EZPQ38855MTA	±5	8.5	30.0	50.5	41.0	37.5	10.2	1.0	50	425	9.5	11.7	102	400
EZPQ38905MTA	±5	9.0	30.0	50.5	41.0	37.5	10.2	1.0	50	450	9.8	11.4	101	400
EZPQ38955MTA	±5	9.5	30.0	50.5	41.0	37.5	10.2	1.0	50	475	10.1	11.0	101	400
EZPQ38106MTA	±5	10.0	30.0	50.5	41.0	37.5	10.2	1.0	50	500	10.4	10.8	101	400
EZPQ38126MTA	±5	12.0	30.0	56.0	41.5	37.5	10.2	1.2	50	600	12.7	8.0	124	400
EZPQ38156MTB	±5	15.0	38.0	57.5	42.0	37.5	10.2	1.2	50	750	14.6	7.1	159	400

*1 : When rising temperature of capacitor surface by continuous peak current(included pulse current), use within limit specified for temperature of capacitor surface and self heating temperature rise.

*2 : Maximum RMS current @ 85°C , 10kHz Use within limit for self heating temperature rise at capacitor surface.

*3 : 20 °C, 10 kHz

*4 : Minimum order quantity consists of 4 packing units.

NEW

Metallized Polypropylene Film Capacitor

EZPV series



Features

- High Safety (with safety function)
- Long product life, High reliability
- Low loss, Low ESR
- Flame retardant (Case and sealing resin)
- AEC-Q200 compliant (For automotive part No.)*¹
- RoHS compliant

Recommended applications

- For DC filtering, DC link circuit
- Solar inverters
- Wind power generation
- Industrial power supplies
- Inverter circuit in appliances (Air Conditioners etc.)
- On board charger, AC/DC, DC/DC converter for automotive

Construction

- Dielectric : Polypropylene film
- Electrodes : Metallized dielectric with segmented pattern
- Plastic case : UL94 V-0
- Sealing : UL94 V-0
- Terminals : Tinned wires, 2-pin and 4-pin versions

Explanation of part number

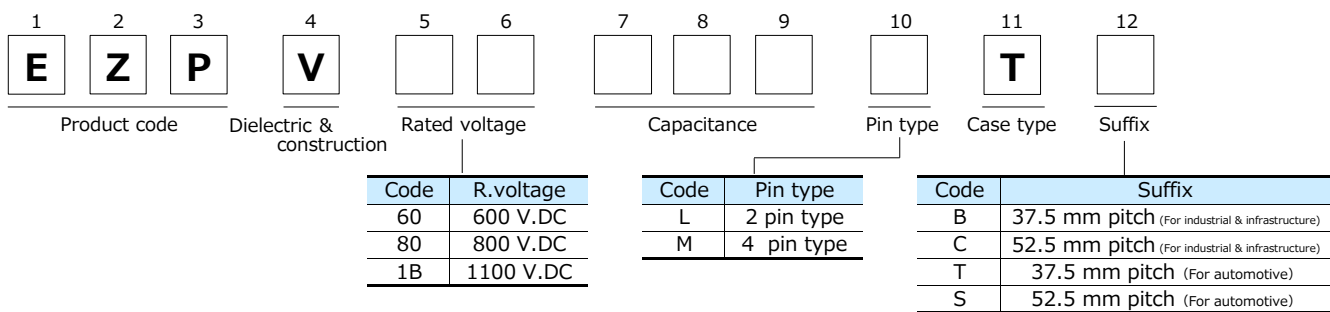

Specifications

Category temperature range* ²	-40 °C to +105 °C	
Rated voltage* ³	600 V.DC, 800 V.DC, 1100 V.DC (Derating of rated voltage by 1.0 %/°C at more than 85 °C)	
Rated capacitance	600 V.DC	10 µF to 110 µF
	800 V.DC	8 µF to 65 µF
	1100 V.DC	3 µF to 40 µF
Capacitance tolerance	±10 %	
Withstand voltage	Between terminals : Rated voltage (V.DC) × 150 % 10 s	
	Terminal to case : 2000 V.AC 10 s	
Insulation resistance (IR)	CR ≥ 3,000 Ω·F (20 °C, 500 V.DC, 60 s)	

*1 : The products are tested based on all or part of the test conditions and methods defined in AEC-Q200.
Please refer to the product specification for the details of the product specification and the test conditions

*2 : The temperature of capacitor surface (case).

*3 : Use for DC voltage only.

Dimensions

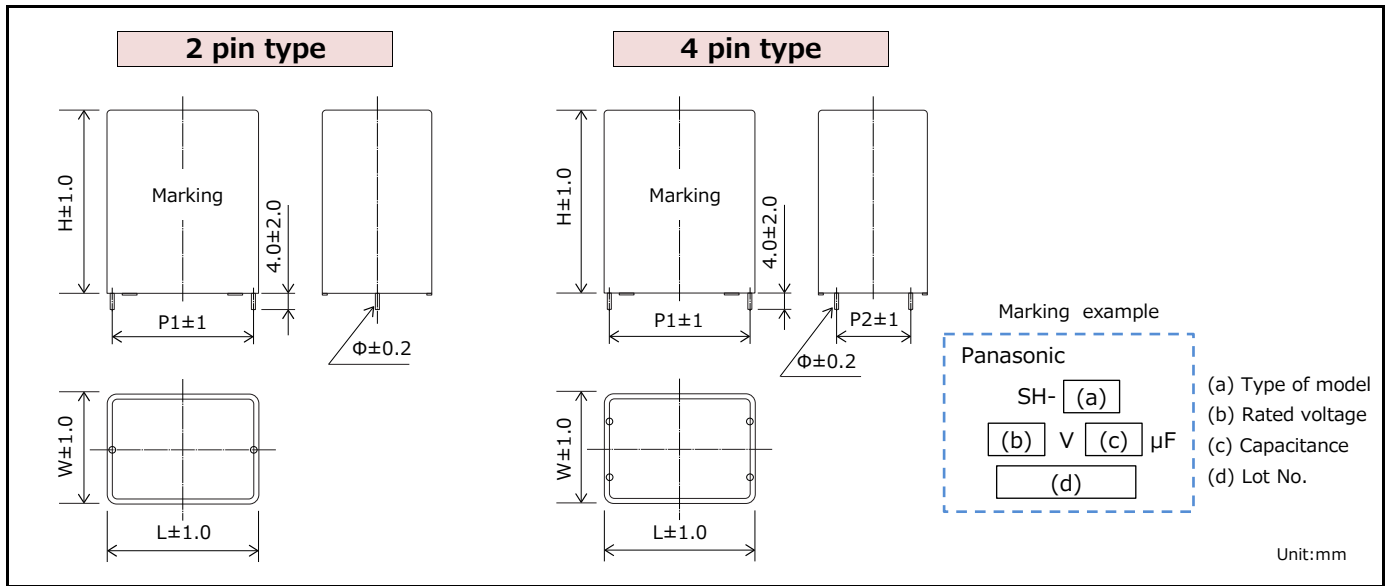

Rating · Dimensions · Quantity

For industrial & infrastructure

■ Rated voltage : 600 V.DC

Part No.	Cap. Tol. (%)	Cap. (μF)	Dimensions (mm)						dv/dt (V/μs)	Permissible current		ESR* ³ (mΩ)	Mass (g)	Min. order Qty* ⁴ (PCS)
			W	H	L	P1	P2	Φ		Peak current* ¹ (A _{0-p})	RMS current* ² (A rms)			
EZPV60106LTB	±10	10	15.0	29.0	41.0	37.5	-	1.0	25	250	8.6	16.9	29	1200
EZPV60126LTB	±10	12	15.0	29.0	41.0	37.5	-	1.0	25	300	9.2	14.3	30	1200
EZPV60156LTB	±10	15	17.0	34.5	41.0	37.5	-	1.0	25	375	10.0	12.8	37	1200
EZPV60206MTB	±10	20	22.0	36.0	41.0	37.5	10.2	1.0	25	500	11.9	10.4	50	600
EZPV60226MTB	±10	22	22.0	36.0	41.0	37.5	10.2	1.0	25	550	12.7	9.6	55	600
EZPV60256MTB	±10	25	22.0	36.0	41.0	37.5	10.2	1.0	25	625	13.8	8.6	58	600
EZPV60306MTB	±10	30	26.0	40.5	41.0	37.5	10.2	1.0	25	750	15.6	8.2	71	600
EZPV60356MTB	±10	35	26.0	40.5	41.0	37.5	10.2	1.0	25	875	17.2	7.1	74	600
EZPV60406MTB	±10	40	27.5	42.0	41.5	37.5	10.2	1.0	25	1000	18.7	6.5	80	600
EZPV60456MTB	±10	45	30.0	50.5	41.0	37.5	20.3	1.0	25	1125	20.1	6.2	94	400
EZPV60506MTB	±10	50	30.0	50.5	41.0	37.5	20.3	1.0	25	1250	21.5	5.3	97	400
EZPV60556MTB	±10	55	30.0	50.5	41.0	37.5	20.3	1.0	25	1375	22.0	4.5	116	400
EZPV60606MTB	±10	60	30.0	56.0	41.5	37.5	20.3	1.2	25	1500	22.5	4.1	120	400
EZPV60656MTB	±10	65	30.0	56.0	41.5	37.5	20.3	1.2	25	1625	23.0	3.6	122	400
EZPV60706MTB	±10	70	38.0	52.5	42.0	37.5	20.3	1.2	25	1750	23.4	3.6	152	400
EZPV60756MTB	±10	75	38.0	57.0	42.0	37.5	20.3	1.2	25	1875	23.8	4.1	153	400
EZPV60806MTB	±10	80	43.0	58.0	41.0	37.5	20.3	1.2	25	2000	24.3	3.9	173	400
EZPV60856MTB	±10	85	43.0	58.0	41.0	37.5	20.3	1.2	25	2125	24.7	3.7	184	400
EZPV60406MTC	±10	40	25.0	40.0	57.0	52.5	10.2	1.2	15	600	16.9	8.4	83	600
EZPV60456MTC	±10	45	25.0	40.0	57.0	52.5	10.2	1.2	15	675	18.0	7.6	86	600
EZPV60506MTC	±10	50	25.0	40.0	57.0	52.5	10.2	1.2	15	750	19.1	6.8	89	600
EZPV60556MTC	±10	55	30.0	51.0	57.5	52.5	10.2	1.2	15	825	20.1	8.0	111	200
EZPV60606MTC	±10	60	30.0	51.0	57.5	52.5	10.2	1.2	15	900	21.0	7.5	115	200
EZPV60656MTC	±10	65	30.0	51.0	57.5	52.5	20.3	1.2	15	975	21.9	7.0	116	200
EZPV60706MTC	±10	70	30.0	51.0	57.5	52.5	20.3	1.2	15	1050	22.8	6.6	120	200
EZPV60756MTC	±10	75	30.0	51.0	57.5	52.5	20.3	1.2	15	1125	23.6	5.5	124	200
EZPV60806MTC	±10	80	30.0	51.0	57.5	52.5	20.3	1.2	15	1200	24.5	4.9	139	200
EZPV60856MTC	±10	85	30.0	51.0	57.5	52.5	20.3	1.2	15	1275	25.3	4.6	144	200
EZPV60906MTC	±10	90	35.0	50.0	57.5	52.5	20.3	1.2	15	1350	26.0	4.7	160	200
EZPV60956MTC	±10	95	35.0	50.0	57.5	52.5	20.3	1.2	15	1425	26.8	5.2	161	200
EZPV60107MTC	±10	100	40.0	51.5	57.0	52.5	20.3	1.2	15	1500	27.5	5.1	190	200
EZPV60117MTC	±10	110	35.0	56.0	57.5	52.5	20.3	1.2	15	1650	28.9	4.8	177	200

*1 : When rising temperature of capacitor surface by continuous peak current(included pulse current), use within limit specified for temperature of capacitor surface and self heating temperature rise.

*2 : Maximum RMS current @ 70°C , 10kHz Use within limit for self heating temperature rise at capacitor surface.

*3 : 20 °C、 10 kHz

*4 : Minimum order quantity consists of 4 packing units.

Rating · Dimensions · Quantity

For industrial & infrastructure

■ Rated voltage : 800 V.DC

Part No.	Cap. Tol. (%)	Cap. (μF)	Dimensions (mm)						dv/dt (V/μs)	Permissible current		ESR* ³ (mΩ)	Mass (g)	Min. order Qty* ⁴ (PCS)
			W	H	L	P1	P2	Φ		Peak current* ¹ (A _{0-p})	RMS current* ² (A rms)			
EZPV80805LTB	±10	8	17.0	34.5	41.0	37.5	-	1.0	35	280	8.2	17.1	36	1200
EZPV80905LTB	±10	9	17.0	34.5	41.0	37.5	-	1.0	35	315	8.9	15.6	37	1200
EZPV80106LTB	±10	10	17.0	34.5	41.0	37.5	-	1.0	35	350	9.5	13.9	38	1200
EZPV80126LTB	±10	12	22.0	36.0	41.0	37.5	-	1.0	35	420	10.7	12.5	49	600
EZPV80156MTB	±10	15	22.0	36.0	41.0	37.5	10.2	1.0	35	525	13.0	10.2	58	600
EZPV80206MTB	±10	20	26.0	40.5	41.0	37.5	10.2	1.0	35	700	15.8	8.7	74	600
EZPV80256MTB	±10	25	30.0	50.5	41.0	37.5	10.2	1.0	35	875	18.3	8.7	91	400
EZPV80306MTB	±10	30	30.0	50.5	41.0	37.5	20.3	1.0	35	1050	20.6	7.1	98	400
EZPV80356MTB	±10	35	30.0	56.0	41.5	37.5	20.3	1.2	35	1225	22.7	5.5	117	400
EZPV80406MTB	±10	40	38.0	52.5	42.0	37.5	20.3	1.2	35	1400	24.6	5.1	152	400
EZPV80456MTB	±10	45	38.0	57.0	42.0	37.5	20.3	1.2	35	1575	26.4	4.5	156	400
EZPV80506MTB	±10	50	43.0	58.0	41.0	37.5	20.3	1.2	35	1750	28.2	4.8	184	400
EZPV80256MTC	±10	25	25.0	40.0	57.0	52.5	10.2	1.2	22	550	14.4	11.6	86	600
EZPV80306MTC	±10	30	30.0	51.0	57.5	52.5	10.2	1.2	22	660	16.8	11.6	111	200
EZPV80356MTC	±10	35	30.0	51.0	57.5	52.5	10.2	1.2	22	770	18.9	10.2	115	200
EZPV80406MTC	±10	40	30.0	51.0	57.5	52.5	20.3	1.2	22	880	20.9	9.1	120	200
EZPV80456MTC	±10	45	30.0	51.0	57.5	52.5	20.3	1.2	22	990	22.8	7.9	125	200
EZPV80506MTC	±10	50	30.0	51.0	57.5	52.5	20.3	1.2	22	1100	24.5	6.8	144	200
EZPV80556MTC	±10	55	35.0	50.0	57.5	52.5	20.3	1.2	22	1210	26.2	6.3	161	200
EZPV80606MTC	±10	60	35.0	56.0	57.5	52.5	20.3	1.2	22	1320	27.8	6.2	176	200
EZPV80656MTC	±10	65	35.0	64.5	57.5	52.5	20.3	1.2	22	1430	29.3	6.2	178	200

■ Rated voltage : 1100 V.DC

Part No.	Cap. Tol. (%)	Cap. (μF)	Dimensions (mm)						dv/dt (V/μs)	Permissible current		ESR* ³ (mΩ)	Mass (g)	Min. order Qty* ⁴ (PCS)
			W	H	L	P1	P2	Φ		Peak current* ¹ (A _{0-p})	RMS current* ² (A rms)			
EZPV1B305LTB	±10	3	15.0	29.0	41.0	37.5	-	1.0	50	150	4.4	30.8	28	1200
EZPV1B405LTB	±10	4	15.0	29.0	41.0	37.5	-	1.0	50	200	5.5	23.5	31	1200
EZPV1B475LTB	±10	4.7	17.0	34.5	41.0	37.5	-	1.0	50	235	6.2	21.7	36	1200
EZPV1B505LTB	±10	5	17.0	34.5	41.0	37.5	-	1.0	50	250	6.5	20.4	37	1200
EZPV1B605LTB	±10	6	17.0	34.5	41.0	37.5	-	1.0	50	300	7.3	17.5	39	1200
EZPV1B705MTB	±10	7	22.0	36.0	41.0	37.5	10.2	1.0	50	350	8.5	15.5	49	600
EZPV1B805MTB	±10	8	22.0	36.0	41.0	37.5	10.2	1.0	50	400	9.5	13.7	56	600
EZPV1B905MTB	±10	9	22.0	36.0	41.0	37.5	10.2	1.0	50	450	10.4	12.4	58	600
EZPV1B106MTB	±10	10	23.5	43.5	41.5	37.5	10.2	1.0	50	500	11.2	12.7	65	400
EZPV1B126MTB	±10	12	26.0	40.5	41.0	37.5	10.2	1.0	50	600	12.8	10.4	74	600
EZPV1B156MTB	±10	15	30.0	50.5	41.0	37.5	10.2	1.0	50	750	15.0	10.4	91	400
EZPV1B186MTB	±10	18	30.0	50.5	41.0	37.5	20.3	1.0	50	900	16.9	8.5	97	400
EZPV1B206MTB	±10	20	30.0	56.0	41.5	37.5	20.3	1.2	50	1000	18.1	7.2	117	400
EZPV1B256MTB	±10	25	38.0	52.5	42.0	37.5	20.3	1.2	50	1250	20.9	5.9	152	400
EZPV1B306MTB	±10	30	43.0	58.0	41.0	37.5	20.3	1.2	50	1500	23.4	5.7	184	400
EZPV1B156MTC	±10	15	25.0	40.0	57.0	52.5	10.2	1.2	30	450	10.6	13.7	84	600
EZPV1B206MTC	±10	20	35.5	45.5	57.5	52.5	10.2	1.2	30	600	12.2	11.2	125	200
EZPV1B256MTC	±10	25	35.5	45.5	57.5	52.5	20.3	1.2	30	750	13.6	9.1	135	200
EZPV1B306MTC	±10	30	35.0	50.0	57.5	52.5	20.3	1.2	30	900	14.9	9.9	142	200
EZPV1B356MTC	±10	35	35.0	56.0	57.5	52.5	20.3	1.2	30	1050	16.1	9.2	170	200
EZPV1B406MTC	±10	40	35.0	56.0	57.5	52.5	20.3	1.2	30	1200	17.2	7.8	177	200

*1 : When rising temperature of capacitor surface by continuous peak current(included pulse current), use within limit specified for temperature of capacitor surface and self heating temperature rise.

*2 : Maximum RMS current @ 70°C , 10kHz Use within limit for self heating temperature rise at capacitor surface.

*3 : 20 °C、10 kHz

*4 : Minimum order quantity consists of 4 packing units.

Rating · Dimensions · Quantity

For automotive

■ Rated voltage : 600 V.DC

Part No.	Cap. Tol. (%)	Cap. (μF)	Dimensions (mm)						dv/dt (V/μs)	Permissible current		ESR* ³ (mΩ)	Mass (g)	Min. order Qty* ⁴ (PCS)
			W	H	L	P1	P2	Φ		Peak current* ¹ (A _{0-p})	RMS current* ² (A rms)			
EZPV60106LTT	±10	10	15.0	29.0	41.0	37.5	-	1.0	25	250	8.6	16.9	29	1200
EZPV60126LTT	±10	12	15.0	29.0	41.0	37.5	-	1.0	25	300	9.2	14.3	30	1200
EZPV60156LTT	±10	15	17.0	34.5	41.0	37.5	-	1.0	25	375	10.0	12.8	37	1200
EZPV60206MTT	±10	20	22.0	36.0	41.0	37.5	10.2	1.0	25	500	11.9	10.4	50	600
EZPV60226MTT	±10	22	22.0	36.0	41.0	37.5	10.2	1.0	25	550	12.7	9.6	55	600
EZPV60256MTT	±10	25	22.0	36.0	41.0	37.5	10.2	1.0	25	625	13.8	8.6	58	600
EZPV60306MTT	±10	30	26.0	40.5	41.0	37.5	10.2	1.0	25	750	15.6	8.2	71	600
EZPV60356MTT	±10	35	26.0	40.5	41.0	37.5	10.2	1.0	25	875	17.2	7.1	74	600
EZPV60406MTT	±10	40	27.5	42.0	41.5	37.5	10.2	1.0	25	1000	18.7	6.5	80	600
EZPV60456MTT	±10	45	30.0	50.5	41.0	37.5	20.3	1.0	25	1125	20.1	6.2	94	400
EZPV60506MTT	±10	50	30.0	50.5	41.0	37.5	20.3	1.0	25	1250	21.5	5.3	97	400
EZPV60556MTT	±10	55	30.0	50.5	41.0	37.5	20.3	1.0	25	1375	22.0	4.5	116	400
EZPV60606MTT	±10	60	30.0	56.0	41.5	37.5	20.3	1.2	25	1500	22.5	4.1	120	400
EZPV60656MTT	±10	65	30.0	56.0	41.5	37.5	20.3	1.2	25	1625	23.0	3.6	122	400
EZPV60706MTT	±10	70	38.0	52.5	42.0	37.5	20.3	1.2	25	1750	23.4	3.6	152	400
EZPV60756MTT	±10	75	38.0	57.0	42.0	37.5	20.3	1.2	25	1875	23.8	4.1	153	400
EZPV60806MTT	±10	80	43.0	58.0	41.0	37.5	20.3	1.2	25	2000	24.3	3.9	173	400
EZPV60856MTT	±10	85	43.0	58.0	41.0	37.5	20.3	1.2	25	2125	24.7	3.7	184	400
EZPV60406MTS	±10	40	25.0	40.0	57.0	52.5	10.2	1.2	15	600	16.9	8.4	83	600
EZPV60456MTS	±10	45	25.0	40.0	57.0	52.5	10.2	1.2	15	675	18.0	7.6	86	600
EZPV60506MTS	±10	50	25.0	40.0	57.0	52.5	10.2	1.2	15	750	19.1	6.8	89	600
EZPV60556MTS	±10	55	30.0	51.0	57.5	52.5	10.2	1.2	15	825	20.1	8.0	111	200
EZPV60606MTS	±10	60	30.0	51.0	57.5	52.5	10.2	1.2	15	900	21.0	7.5	115	200
EZPV60656MTS	±10	65	30.0	51.0	57.5	52.5	20.3	1.2	15	975	21.9	7.0	116	200
EZPV60706MTS	±10	70	30.0	51.0	57.5	52.5	20.3	1.2	15	1050	22.8	6.6	120	200
EZPV60756MTS	±10	75	30.0	51.0	57.5	52.5	20.3	1.2	15	1125	23.6	5.5	124	200
EZPV60806MTS	±10	80	30.0	51.0	57.5	52.5	20.3	1.2	15	1200	24.5	4.9	139	200
EZPV60856MTS	±10	85	30.0	51.0	57.5	52.5	20.3	1.2	15	1275	25.3	4.6	144	200
EZPV60906MTS	±10	90	35.0	50.0	57.5	52.5	20.3	1.2	15	1350	26.0	4.7	160	200
EZPV60956MTS	±10	95	35.0	50.0	57.5	52.5	20.3	1.2	15	1425	26.8	5.2	161	200
EZPV60107MTS	±10	100	40.0	51.5	57.0	52.5	20.3	1.2	15	1500	27.5	5.1	190	200
EZPV60117MTS	±10	110	35.0	56.0	57.5	52.5	20.3	1.2	15	1650	28.9	4.8	177	200

*1 : When rising temperature of capacitor surface by continuous peak current(included pulse current), use within limit specified for temperature of capacitor surface and self heating temperature rise.

*2 : Maximum RMS current @ 70°C , 10kHz Use within limit for self heating temperature rise at capacitor surface.

*3 : 20 °C、10 kHz

*4 : Minimum order quantity consists of 4 packing units.

Rating · Dimensions · Quantity

For automotive

■ Rated voltage : 800 V.DC

Part No.	Cap. Tol. (%)	Cap. (μF)	Dimensions (mm)						dv/dt (V/μs)	Permissible current		ESR* ³ (mΩ)	Mass (g)	Min. order Qty* ⁴ (PCS)
			W	H	L	P1	P2	Φ		Peak current* ¹ (A _{0-p})	RMS current* ² (A rms)			
EZPV80805LTT	±10	8	17.0	34.5	41.0	37.5	-	1.0	35	280	8.2	17.1	36	1200
EZPV80905LTT	±10	9	17.0	34.5	41.0	37.5	-	1.0	35	315	8.9	15.6	37	1200
EZPV80106LTT	±10	10	17.0	34.5	41.0	37.5	-	1.0	35	350	9.5	13.9	38	1200
EZPV80126LTT	±10	12	22.0	36.0	41.0	37.5	-	1.0	35	420	10.7	12.5	49	600
EZPV80156MTT	±10	15	22.0	36.0	41.0	37.5	10.2	1.0	35	525	13.0	10.2	58	600
EZPV80206MTT	±10	20	26.0	40.5	41.0	37.5	10.2	1.0	35	700	15.8	8.7	74	600
EZPV80256MTT	±10	25	30.0	50.5	41.0	37.5	10.2	1.0	35	875	18.3	8.7	91	400
EZPV80306MTT	±10	30	30.0	50.5	41.0	37.5	20.3	1.0	35	1050	20.6	7.1	98	400
EZPV80356MTT	±10	35	30.0	56.0	41.5	37.5	20.3	1.2	35	1225	22.7	5.5	117	400
EZPV80406MTT	±10	40	38.0	52.5	42.0	37.5	20.3	1.2	35	1400	24.6	5.1	152	400
EZPV80456MTT	±10	45	38.0	57.0	42.0	37.5	20.3	1.2	35	1575	26.4	4.5	156	400
EZPV80506MTT	±10	50	43.0	58.0	41.0	37.5	20.3	1.2	35	1750	28.2	4.8	184	400
EZPV80256MTS	±10	25	25.0	40.0	57.0	52.5	10.2	1.2	22	550	14.4	11.6	86	600
EZPV80306MTS	±10	30	30.0	51.0	57.5	52.5	10.2	1.2	22	660	16.8	11.6	111	200
EZPV80356MTS	±10	35	30.0	51.0	57.5	52.5	10.2	1.2	22	770	18.9	10.2	115	200
EZPV80406MTS	±10	40	30.0	51.0	57.5	52.5	20.3	1.2	22	880	20.9	9.1	120	200
EZPV80456MTS	±10	45	30.0	51.0	57.5	52.5	20.3	1.2	22	990	22.8	7.9	125	200
EZPV80506MTS	±10	50	30.0	51.0	57.5	52.5	20.3	1.2	22	1100	24.5	6.8	144	200
EZPV80556MTS	±10	55	35.0	50.0	57.5	52.5	20.3	1.2	22	1210	26.2	6.3	161	200
EZPV80606MTS	±10	60	35.0	56.0	57.5	52.5	20.3	1.2	22	1320	27.8	6.2	176	200
EZPV80656MTS	±10	65	35.0	64.5	57.5	52.5	20.3	1.2	22	1430	29.3	6.2	178	200

■ Rated voltage : 1100 V.DC

Part No.	Cap. Tol. (%)	Cap. (μF)	Dimensions (mm)						dv/dt (V/μs)	Permissible current		ESR* ³ (mΩ)	Mass (g)	Min. order Qty* ⁴ (PCS)
			W	H	L	P1	P2	Φ		Peak current* ¹ (A _{0-p})	RMS current* ² (A rms)			
EZPV1B305LTT	±10	3	15.0	29.0	41.0	37.5	-	1.0	50	150	4.4	30.8	28	1200
EZPV1B405LTT	±10	4	15.0	29.0	41.0	37.5	-	1.0	50	200	5.5	23.5	31	1200
EZPV1B475LTT	±10	4.7	17.0	34.5	41.0	37.5	-	1.0	50	235	6.2	21.7	36	1200
EZPV1B505LTT	±10	5	17.0	34.5	41.0	37.5	-	1.0	50	250	6.5	20.4	37	1200
EZPV1B605LTT	±10	6	17.0	34.5	41.0	37.5	-	1.0	50	300	7.3	17.5	39	1200
EZPV1B705MTT	±10	7	22.0	36.0	41.0	37.5	10.2	1.0	50	350	8.5	15.5	49	600
EZPV1B805MTT	±10	8	22.0	36.0	41.0	37.5	10.2	1.0	50	400	9.5	13.7	56	600
EZPV1B905MTT	±10	9	22.0	36.0	41.0	37.5	10.2	1.0	50	450	10.4	12.4	58	600
EZPV1B106MTT	±10	10	23.5	43.5	41.5	37.5	10.2	1.0	50	500	11.2	12.7	65	400
EZPV1B126MTT	±10	12	26.0	40.5	41.0	37.5	10.2	1.0	50	600	12.8	10.4	74	600
EZPV1B156MTT	±10	15	30.0	50.5	41.0	37.5	10.2	1.0	50	750	15.0	10.4	91	400
EZPV1B186MTT	±10	18	30.0	50.5	41.0	37.5	20.3	1.0	50	900	16.9	8.5	97	400
EZPV1B206MTT	±10	20	30.0	56.0	41.5	37.5	20.3	1.2	50	1000	18.1	7.2	117	400
EZPV1B256MTT	±10	25	38.0	52.5	42.0	37.5	20.3	1.2	50	1250	20.9	5.9	152	400
EZPV1B306MTT	±10	30	43.0	58.0	41.0	37.5	20.3	1.2	50	1500	23.4	5.7	184	400
EZPV1B156MTS	±10	15	25.0	40.0	57.0	52.5	10.2	1.2	30	450	10.6	13.7	84	600
EZPV1B206MTS	±10	20	35.5	45.5	57.5	52.5	10.2	1.2	30	600	12.2	11.2	125	200
EZPV1B256MTS	±10	25	35.5	45.5	57.5	52.5	20.3	1.2	30	750	13.6	9.1	135	200
EZPV1B306MTS	±10	30	35.0	50.0	57.5	52.5	20.3	1.2	30	900	14.9	9.9	142	200
EZPV1B356MTS	±10	35	35.0	56.0	57.5	52.5	20.3	1.2	30	1050	16.1	9.2	170	200
EZPV1B406MTS	±10	40	35.0	56.0	57.5	52.5	20.3	1.2	30	1200	17.2	7.8	177	200

*1 : When rising temperature of capacitor surface by continuous peak current(included pulse current), use within limit specified for temperature of capacitor surface and self heating temperature rise.

*2 : Maximum RMS current @ 70°C , 10kHz Use within limit for self heating temperature rise at capacitor surface.

*3 : 20 °C、10 kHz

*4 : Minimum order quantity consists of 4 packing units.

CAUTION AND WARNING

1. The electronic components contained in this catalog are designed and produced for use in home electric appliances, office equipment, information equipment, communications equipment, and other general purpose electronic devices.
Before use of any of these components for equipment that requires a high degree of safety, such as medical instruments, aerospace equipment, disaster-prevention equipment, security equipment, vehicles (automobile, train, vessel), please be sure to contact our sales representative corporation.
2. When applying one of these components for equipment requiring a high degree of safety, no matter what sort of application it might be, be sure to install a protective circuit or redundancy arrangement to enhance the safety of your equipment. In addition, please carry out the safety test on your own responsibility.
3. When using our products, no matter what sort of equipment they might be used for, be sure to make a written agreement on the specifications with us in advance.
4. Technical information contained in this catalog is intended to convey examples of typical performances and or applications and is not intended to make any warranty with respect to the intellectual property rights or any other related rights of our company or any third parties nor grant any license under such rights.
5. In order to export products in this catalog, the exporter may be subject to the export license requirement under the Foreign Exchange and Foreign Trade Law of Japan.
6. No ozone-depleting substances (ODSs) under the Montreal Protocol are used in the manufacturing processes of Automotive & Industrial Systems Company, Panasonic Corporation.

● Please contact

● Factory

Device Solutions Business Division
Industrial Solutions Company

Panasonic[®]

1006 Kadoma, Kadoma City, Osaka 571-8506,
JAPAN

The information in this catalog is valid as of December 2019.