



FINISAR[®]

swdm4[®]

Cost-effective 40G/100G Data Center Upgrades

Key Message: Use SWDM4 for Data Center Upgrades

- SWDM4 transceivers provide numerous advantages when upgrading networks from 10G to 40G/100G, specially for enterprises and small cloud service providers.
- **SWDM4 works on installed/legacy OM3/OM4 multimode fiber.** Additionally, it supports an **extended link length** when used with new wideband **OM5 multimode fiber**.
- **SWDM4 uses the industry-preferred duplex LC connector instead of MPO.** It uses two fibers (**duplex**) instead of eight fibers like SR4, **enabling fiber infrastructure cost savings**.
- Availability: Both 40G and 100G QSFP SWDM4 modules are **in full production** at Finisar.
- **Industry adoption:** SWDM4 is backed by an industry MSA. To-date, Finisar SWDM4 modules have completed 24 customer qualifications, with another 11 ongoing (a mix of system OEMs and end users). The following system OEMs have already published SWDM4 products on their public websites and/or product literature:
 - Arista (100G SWDM4)
 - Dell (40G and 100G SWDM4)
 - Extreme Networks (100G SWDM4)
 - H3C (40G and 100G SWDM4)
 - Huawei (100G SWDM4)
- **Finisar whitepaper** covering our SWDM4 products is available.
 - Posted on our external website and on our partner sites. See: <http://www.finisar.com/swdm4>
 - It can also be found as an article here: <https://www.cablinginstall.com/articles/2018/10/swdm-40g-100g-enterprise-data-center.html>

Many Types of 100G QSFP28 Modules in the Market^(*)

	PARALLEL (MPO)	DUPLEX (LC)
MULTIMODE	SR4 & 4x25G-SR (breakouts) 70/100/100m SR4 w/Low-Latency 30/40/40m eSR4 200/300/300m	Support for existing 10G fiber infrastructure?
SINGLE MODE	PSM4 500m	LR4 / eCWDM4 (4WDM-10) 10km CWDM4 2km eLR4 (4WDM-20) 20km ER4f (4WDM-40) 40km

BLACK = Standardized IEEE interfaces

RED = MSA or Proprietary interfaces

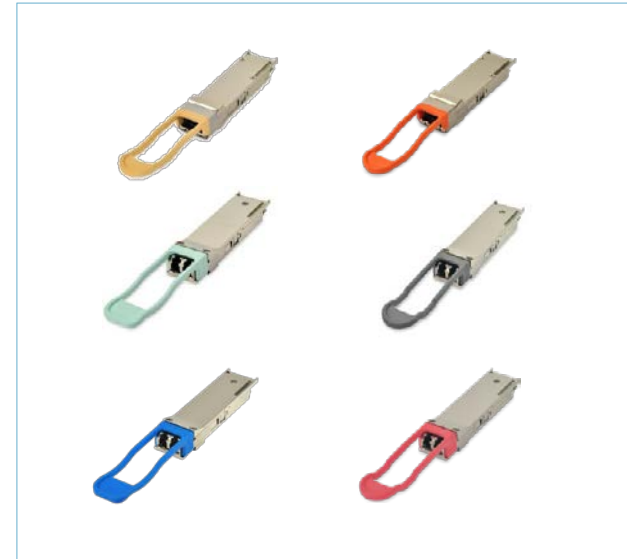

Multimode distances refer to OM3/OM4/OM5 MMF; Single mode distances refer to SMF.

^(*) Announced to be either in production or under development by at least one optical supplier.

Why Duplex Multimode Fiber Matters

- **For Brownfield Applications:**
 - Enterprise data centers have deployed a large amount of 10G Ethernet
 - Primarily 10GBASE-SR over duplex MMF, using LC connectors
- As they migrate from 10G to 40G/100G, most enterprise data centers want to maintain their existing fiber infrastructure.
 - SR4 however requires using 8 fibers instead of 2 fibers (duplex).
 - SR4 also requires new patch cords with MPO connectors (not LC).

Many data centers want to upgrade from 10G to 40G and 100G
without changing their duplex MMF + LC infrastructure

Responding to Market Needs: SWDM4

- **Shortwave WDM (SWDM)** technology uses multiple wavelengths in the 850nm region, optically multiplexed and demultiplexed inside the transceiver.
- SWDM4 enables the transmission of 40G (4x10G) and 100G (4x25G) **over existing OM3/OM4 duplex multimode fiber with LC connectors.**
- 40G and 100G QSFP SWDM4 modules are already available and have been publicly demonstrated.



swdm4[®]

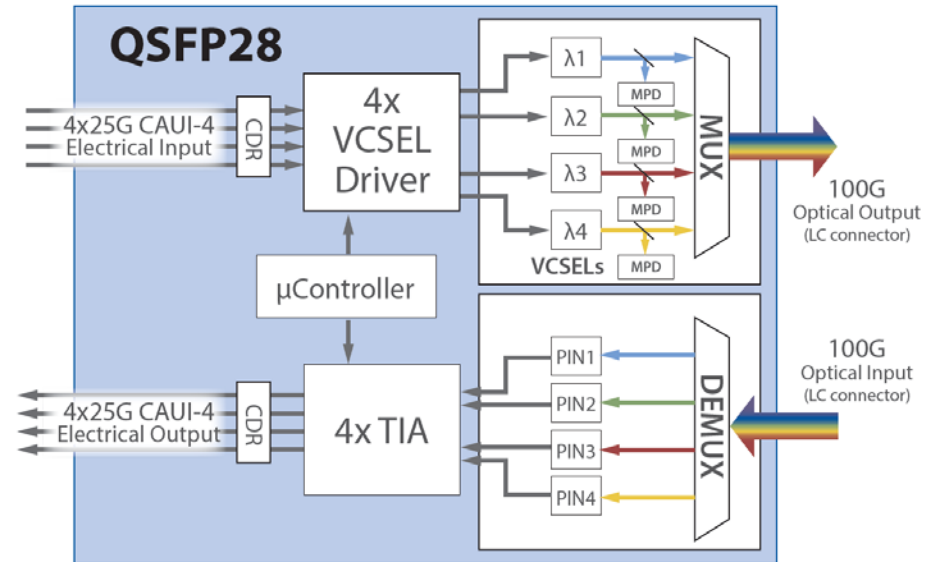

Why Duplex Multimode Fiber Matters

- **For Greenfield Applications:**

- Many new data centers require very high bandwidth density and longer reaches.
- SWDM4 requires **2 fibers** per full-duplex link instead of 8 fibers like SR4. This significantly **decreases the cost** of new OM3/OM4 multimode fiber trunks/structured cabling infrastructure, while still using cost-effective multimode transceivers.
- For larger data centers, **new OM5 multimode fiber can extend the reach of SWDM4 optics**, since it allows wavelengths up to 953nm to propagate further.
- OM5 fiber also **future-proofs the infrastructure** for possible future 200G, 400G and 800G interfaces.

For new data centers using 40G/100G, *SWDM4 is a great solution to decrease infrastructure cost, and/or to increase link performance.*

- Industry group to promote SWDM technology for duplex multimode fiber in data centers.
- Finisar is a founding member of the SWDM Alliance and SWDM MSA.
- More information at www.swdm.org

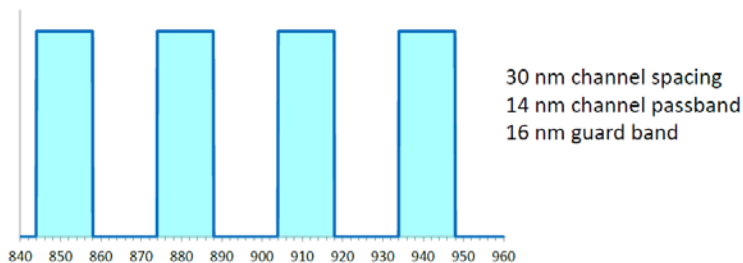

Nominal channel wavelength, nm							
850		880		910		940	
start	stop	start	stop	start	stop	start	stop
844	858	874	888	904	918	934	948

Source: SWDM MSA

Anritsu COMMSCOPE®

CORNING DELL EMC

FINISAR® H3C

Hisense HUAWEI

HUBER+SUHNER Excellence in Connectivity Solutions INNEOS

JUNIPER NETWORKS LUMENTUM ofS A Furukawa Company

PANDUIT® Prysmian Group SURUGA SEIKI

YOFC 长飞

System OEMs Publicly Offering SWDM4 Products

System OEM	URL
100G SWDM4 QSFP28	
Arista	https://www.arista.com/en/products/transceivers-cables
Dell	http://i.dell.com/sites/doccontent/shared-content/data-sheets/en/Documents/Dell-Networking-Optics-Spec-Sheet.pdf
Extreme Networks	https://cloud.kapostcontent.net/pub/1360b218-a70e-4d4a-b038-2514165bacca/100gb-qsfp28-transceivers-and-cables-data-sheet.pdf?kui=8f3kjatplk8K9f18_FXCw
H3C	http://www.h3c.com.hk/Technical_Support_Documents/Technical_Documents/Switches/H3C_S12500/H3C_S12500_Series_Switches/Installation/Installation_Manual/H3C_Transceiver_Modules_UG-6W107/201806/1088945_1285_0.htm#_Toc517271371
Huawei	https://e.huawei.com/en/material/onLineView?materialid=59420abb35834c118283537ff0718484
40G SWDM4 QSFP+	
Dell	http://i.dell.com/sites/doccontent/shared-content/data-sheets/en/Documents/Dell-Networking-Optics-Spec-Sheet.pdf
H3C	http://www.h3c.com.hk/Technical_Support_Documents/Technical_Documents/Switches/H3C_S12500/H3C_S12500_Series_Switches/Installation/Installation_Manual/H3C_Transceiver_Modules_UG-6W107/201806/1088945_1285_0.htm#_Toc517271399

40G and 100G SWDM4 QSFP Transceivers

- Lowest total link cost for enterprise and small cloud data centers
- Supports both legacy and wideband **duplex multimode fiber**.
- Uses duplex LC connectors.
- 4x10G or 4x25G VCSEL transmitters.
- Fully electrically and mechanically compliant to QSFP host requirements.
- Finisar 40G/100G SWDM4 QSFP modules are **in full production**, and they exceed the requirements of the SWDM MSA:



swdm4[®]

Data Rate	Module Type	Finisar Part Number	OM3 Reach	OM4 Reach	OM5 Reach
40G	QSFP+ SWDM4	FTL4S1QE2C	300m	400m	500m
100G	QSFP28 SWDM4	FTLC9152RGPL	100m	150m	180m

Using QSFP SWDM4 Transceivers

Structured Cabling with 40G/100G SR4 optics

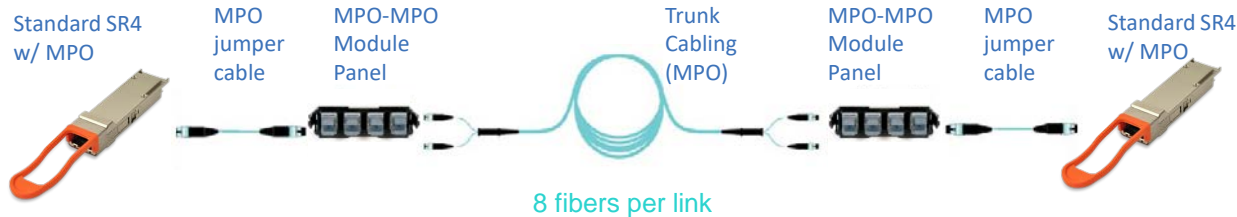

Savings by using SWDM4 optics:

- Reuse existing 10G fiber cabling infrastructure.
- Use 2 instead of 8 multimode fiber strands per link.
- Continue using the well-known LC connector.

Structured Cabling with 40G/100G SWDM4 optics

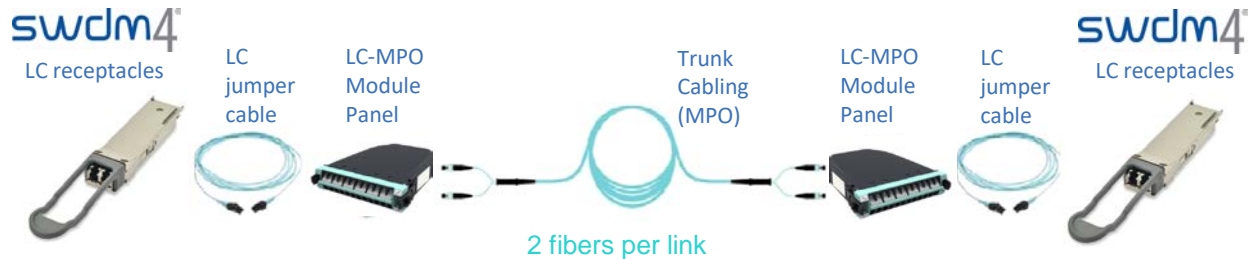

SWDM4 or BiDi Transceivers?

- 40G/100G BiDi QSFP transceivers also enable the use of duplex multimode fiber.
- However, **SWDM4 offers several advantages** with respect to BiDi transceivers:
 - 40G/100G SWDM4 supports **longer reaches** on all multimode fiber types (OM3, OM4 and OM5).
 - 40G/100G SWDM4 is backed by an **industry Alliance and an MSA**.
 - 40G/100G SWDM4 can be easily tapped for **network traffic/performance monitoring** (it does not require special bidi taps or transceivers without transmitters).

Advantages of SWDM4 vs. BiDi Modules

- The **reach of Finisar 40G SWDM4 (Gen2) is 300/400/500m** on OM3/OM4/OM5 MMF respectively, versus only 100/150/200m on OM3/OM4/OM5 MMF for 40G BiDi. They interoperate with SWDM MSA compliant modules.
- The latest **reach of Finisar 100G SWDM4 is 100/150/180m** on OM3/OM4/OM5 MMF respectively, versus only 70/100/150m on OM3/OM4/OM5 MMF for 100G BiDi. They interoperate with SWDM MSA compliant modules.
- 40G/100G BiDi is a one-vendor solution (proprietary to FIT), while **40G/100G SWDM4 is backed by an industry Alliance and an MSA**, which means that its optical spec has been published and that any optics vendor (not only those that are MSA members) can design an interoperable product. See: www.swdm.org and www.swdm.org/msa Having multiple sources ensures that SWDM4 will be a more price-competitive solution in high market volumes.
- **SWDM4 can easily be tapped for traffic/performance monitoring** since one fiber strand contains all wavelengths in each direction (similar to LR4 or CWDM4). BiDi is more complex to tap since both fiber strands carry signals in each direction, requiring special bidirectional taps and special transceivers (without Tx) in the monitoring equipment, in order to avoid link performance issues.
- **Multiple system OEMs are expected to support SWDM4.** We cannot provide many details due to NDAs but users should look at the SWDM Alliance members for guidance. **Arista, Dell, Huawei, H3C and Extreme Networks** have already posted their QSFP SWDM4 part numbers on their public websites and/or product literature. Note that Arista has announced they support 100G QSFP28 SWDM4 (even if they're not an SWDM Alliance member). See: https://www.arista.com/assets/data/pdf/Arista100G_TC_QA.pdf
- Even though BiDi technology was recently chosen for each of four 100G lanes in the new 400GBASE-SR4.2 standard, there are no plans currently at the IEEE to standardize a "100G-SR1.2" BiDi interface. Additionally, it is expected to take many years for the enterprise market to start deploying multimode 400G SR4.2 ports.



FINISAR[®]

swdm4[®]

Please contact sales@finisar.com

