

FEATURES AND BENEFITS*

- Up to 500,000 duty cycles or 10 year life
- Low internal resistance
- High power density
- 1F to 150F capacitance range
- -40° to 85°C operating temperature range

TYPICAL APPLICATIONS

- Back-up power for cache-to-flash applications
- Smart Meters
- Automotive subsystems
- Consumer and industrial electronics
- Wireless transmitters



PRODUCT SPECIFICATIONS

ELECTRICAL	BCAP0001	BCAP0003	BCAP0005	BCAP0010 T01/T11/T12
Rated Capacitance ¹	1 F	3.3 F	5 F	10 F
Minimum Capacitance, initial ¹	0.8 F	2.6 F	4.0 F	8.0 F
Maximum ESR _{DC} , initial ¹	700 mΩ	290 mΩ	170 mΩ	75 mΩ
Test Current for Capacitance and ESR _{DC} ¹	0.1 A	0.33 A	0.5 A	1 A
Rated Voltage (65°/85°C)	2.70 / 2.30 V	2.70 / 2.30 V	2.70 / 2.30 V	2.70 / 2.30 V
Absolute Maximum Voltage ²	2.85 V	2.85 V	2.85 V	2.85 V
Absolute Maximum Current	0.8 A	1.9 A	3.2 A	7.2 A
Leakage Current at 25°C, maximum ³	0.006 mA	0.012 mA	0.015 mA	0.030 mA

TEMPERATURE				
Operating temperature range (Cell case temperature)				
Minimum	-40°C	-40°C	-40°C	-40°C
Maximum	65° / 85°C	65° / 85°C	65° / 85°C	65° / 85°C
Storage temperature range (Stored uncharged)				
Minimum	-40°C	-40°C	-40°C	-40°C
Maximum	70°C	70°C	70°C	70°C

PHYSICAL				
Mass, typical	1.1 g	1.7 g	2.3 g	3.5 g
Terminals	Wire Leads	Wire Leads	Wire Leads	Wire Leads
Vibration	-	-	-	-
Shock	-	-	-	-

*Results may vary. Additional terms and conditions, including the limited warranty, apply at the time of purchase. See the warranty details and enclosed information for applicable operating and use requirements.

PRODUCT SPECIFICATIONS (Cont'd)

ELECTRICAL	BCAP0025 T01/T11	BCAP0050	BCAP0100 T01	BCAP0100 T07	BCAP0150
Rated Capacitance ¹	25 F	50 F	100 F	100 F	150 F
Minimum Capacitance, initial ¹	25 F	50 F	100 F	100 F	150 F
Maximum ESR _{DC} , initial ¹	42 mΩ	20 mΩ	15 mΩ	15 mΩ	14 mΩ
Test Current for Capacitance and ESR _{DC} ¹	2.5 A	5 A	10 A	10 A	15 A
Rated Voltage (65°/85°C)	2.70 / 2.30 V	2.70 / 2.30 V	2.70 / 2.30 V	2.70 / 2.30 V	2.70 / 2.30 V
Absolute Maximum Voltage ²	2.85 V	2.85 V	2.85 V	2.85 V	2.85 V
Absolute Maximum Current	20 A	27 A	36 A	36 A	40 A
Leakage Current at 25°C, maximum ³	0.045 mA	0.075 mA	0.260 mA	0.260 mA	0.500 mA
TEMPERATURE					
Operating temperature range (Cell case temperature)					
Minimum	-40°C	-40°C	-40°C	-40°C	-40°C
Maximum	65° / 85°C	65° / 85°C	65° / 85°C	65° / 85°C	65° / 85°C
Storage temperature range (Stored uncharged)					
Minimum	-40°C	-40°C	-40°C	-40°C	-40°C
Maximum	70°C	70°C	70°C	70°C	70°C
PHYSICAL					
Mass, typical	7.5 g	13 g	23 g	22 g	32 g
Terminals	Wire Leads	Wire Leads	Wire Leads	Snap In	Snap in
Vibration	-	-	-	-	-
Shock	-	-	-	-	-

PRODUCT SPECIFICATIONS (Cont'd)

POWER & ENERGY AT 2.7V	BCAP0001	BCAP0003	BCAP0005	BCAP0010 T01/T11/T12
Usable Specific Power, P_d^4	1,100 W/kg	1,800 W/kg	2,200 W/kg	3,300 W/kg
Impedance Match Specific Power, P_{max}^5	2,400 W/kg	3,700 W/kg	4,700 W/kg	6,900 W/kg
Specific Energy, E_{max}^6	0.9 Wh/kg	2.0 Wh/kg	2.2 Wh/kg	2.9 Wh/kg
Stored Energy, $E_{stored}^{7,11}$	0.001 Wh	0.003 Wh	0.005 Wh	0.010 Wh

SAFETY

Short Circuit Current, typical (Current possible with short circuit from rated voltage. Do not use as an operating current.)	4 A	9 A	16 A	36 A
Certifications	UL810a, RoHS	UL810a, RoHS	UL810a, RoHS	UL810a, RoHS

TYPICAL CHARACTERISTICS

THERMAL CHARACTERISTICS

Thermal Resistance (R_{ca} , Case to Ambient), typical ⁸	120°C/W	76°C/W	73°C/W	43°C/W
Thermal Capacitance (C_{th}), typical	1.0 J/°C	1.4 J/°C	2.0 J/°C	3.6 J/°C
Maximum Continuous Current ($\Delta T = 15^\circ C$) ⁸	0.4 A _{RMS}	0.8 A _{RMS}	1.1 A _{RMS}	2.2 A _{RMS}
Maximum Continuous Current ($\Delta T = 40^\circ C$) ⁸	0.7 A _{RMS}	1.3 A _{RMS}	1.8 A _{RMS}	3.5 A _{RMS}

PRODUCT SPECIFICATIONS (Cont'd)

POWER & ENERGY AT 2.7V	BCAP0025 T01/T11	BCAP0050	BCAP0100 T01	BCAP0100 T07	BCAP0150
Usable Specific Power, P_d^4	2,800 W/kg	3,400 W/kg	2,500 W/kg	2,700 W/kg	2,000 W/kg
Impedance Match Specific Power, P_{max}^5	5,800 W/kg	7,000 W/kg	5,300 W/kg	5,500 W/kg	4,100 W/kg
Specific Energy, E_{max}^6	3.4 Wh/kg	3.9 Wh/kg	4.4 Wh/kg	4.6 Wh/kg	4.7 Wh/kg
Stored Energy, $E_{stored}^{7,11}$	0.025 Wh	0.051 Wh	0.101 Wh	0.101 Wh	0.152 Wh

SAFETY

Short Circuit Current, typical (Current possible with short circuit from rated voltage. Do not use as an operating current.)	64 A	140 A	180 A	180 A	190 A
Certifications	UL810a, RoHS	UL810a, RoHS	UL810a, RoHS	UL810a, RoHS	UL810a, RoHS

TYPICAL CHARACTERISTICS

THERMAL CHARACTERISTICS

Thermal Resistance (R_{ca} , Case to Ambient), typical ⁸	47°C/W	26°C/W	22°C/W	22°C/W	18°C/W
Thermal Capacitance (C_{th}), typical	6.3 J/°C	13 J/°C	23 J/°C	23 J/°C	32
Maximum Continuous Current ($\Delta T = 15^\circ C$) ⁸	2.8 A _{RMS}	5.4 A _{RMS}	6.7 A _{RMS}	6.7 A _{RMS}	7.7 A _{RMS}
Maximum Continuous Current ($\Delta T = 40^\circ C$) ⁸	4.5 A _{RMS}	8.8 A _{RMS}	11 A _{RMS}	11 A _{RMS}	13 A _{RMS}

TYPICAL CHARACTERISTICS (Cont'd)

LIFE	BCAP0001	BCAP0003	BCAP0005	BCAP0010 T01/T11/T12
DC Life at High Temperature ¹ (held continuously at Rated Voltage & Maximum Operating Temperature)	1,000 hours	1,000 hours	1,000 hours	1,000 hours
Capacitance Change (% decrease from minimum initial value)	30%	30%	30%	30%
ESR Change (% increase from maximum initial value)	100%	100%	100%	100%
Projected DC Life at 25°C ¹ (at Rated Voltage & 25°C)	10 years	10 years	10 years	10 years
Capacitance Change (% decrease from minimum initial value)	30%	30%	30%	30%
ESR Change (% increase from maximum initial value)	100%	100%	100%	100%
Projected Cycle Life at 25°C ^{1,9,10}	500,000 cycles	500,000 cycles	500,000 cycles	500,000 cycles
Capacitance Change (% decrease from minimum initial value)	30%	30%	30%	30%
ESR Change (% increase from maximum initial value)	100%	100%	100%	100%
Test Current	0.1 A	0.33 A	0.5 A	1.0 A
Shelf Life (Stored uncharged at 25°C)	2 years	2 years	2 years	2 years

ESR AND CAPACITANCE VS TEMPERATURE

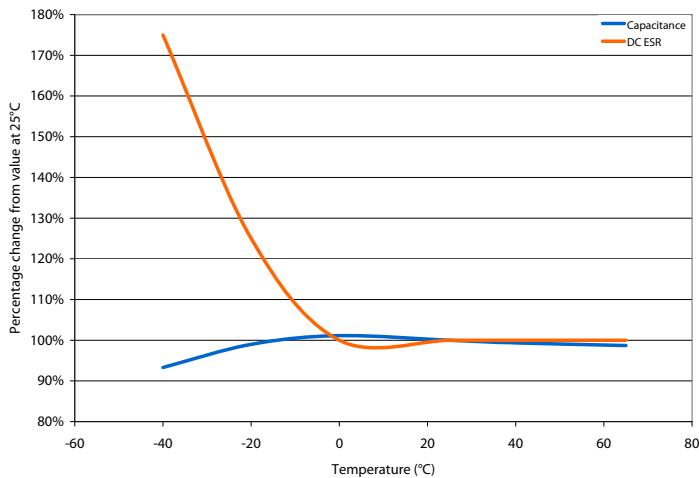

TYPICAL CHARACTERISTICS (Cont'd)

LIFE	BCAP0025 T01/ T11	BCAP0050	BCAP0100 T01	BCAP0100 T07	BCAP0150
DC Life at High Temperature ¹ (at Rated Voltage & Maximum Operating Temperature)	1,000 hours	1,000 hours	1,000 hours	1,000 hours	1,000 hours
Capacitance Change (% decrease from minimum initial value)	30%	30%	30%	30%	30%
ESR Change (% increase from maximum initial value)	100%	100%	100%	100%	100%
Projected DC Life at 25°C ¹ (at Rated Voltage & 25°C)	10 years	10 years	10 years	10 years	10 years
Capacitance Change (% decrease from minimum initial value)	30%	30%	30%	30%	30%
ESR Change (% increase from maximum initial value)	100%	100%	100%	100%	100%
Projected Cycle Life at 25°C ^{1,9,10}	500,000 cycles	500,000 cycles	500,000 cycles	500,000 cycles	500,000 cycles
Capacitance Change (% decrease from minimum initial value)	30%	30%	30%	30%	30%
ESR Change (% increase from maximum initial value)	100%	100%	100%	100%	100%
Test Current	2.5 A	5 A	10 A	10 A	15 A
Shelf Life (Stored uncharged at 25°C)	2 years	2 years	2 years	2 years	2 years

NOTES

1. Capacitance and ESR_{DC} measured at 25°C using specified test current per waveform below.
2. Absolute maximum voltage, non-repeated. Not to exceed 1 second.
3. After 72 hours at rated voltage. Initial leakage current can be higher.
4. Per IEC 62391-2, $P_d = \frac{0.12V^2}{ESR_{DC} \times \text{mass}}$
5. $P_{max} = \frac{V^2}{4 \times ESR_{DC} \times \text{mass}}$
6. $E_{max} = \frac{1/2 CV^2}{3,600 \times \text{mass}}$
7. $E_{stored} = \frac{1/2 CV^2}{3,600}$
8. $\Delta T = I_{RMS}^2 \times ESR \times R_{ca}$
9. Cycle using specified test current per waveform below.
10. Cycle life varies depending upon application-specific characteristics. Actual results will vary.
11. Per United Nations material classification UN3499, all Maxwell ultracapacitors have less than 10 Wh capacity to meet the requirements of Special Provisions 361. Both individual ultracapacitors and modules composed of those ultracapacitors shipped by Maxwell can be transported without being treated as dangerous goods (hazardous materials) under transportation regulations.

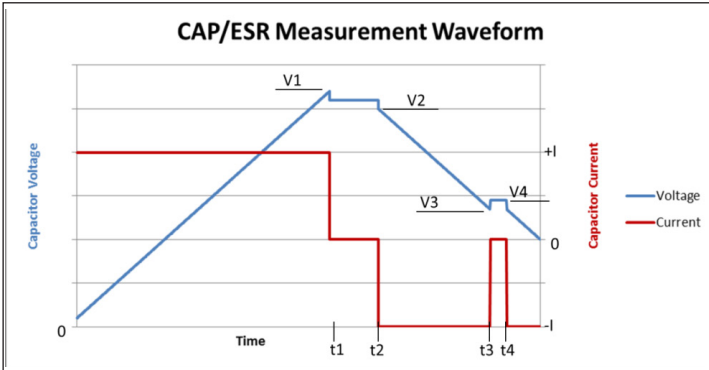

$V1 = V_{rated}$ $t2 - t1 = 15 \text{ seconds}$ $\text{Capacitance} = I \times (t3 - t2) / (V2 - V3)$
 $V3 = 0.5 \times V_{rated}$ $t4 - t3 = 5 \text{ seconds}$ $\text{ESR} = (V4 - V3) / I$

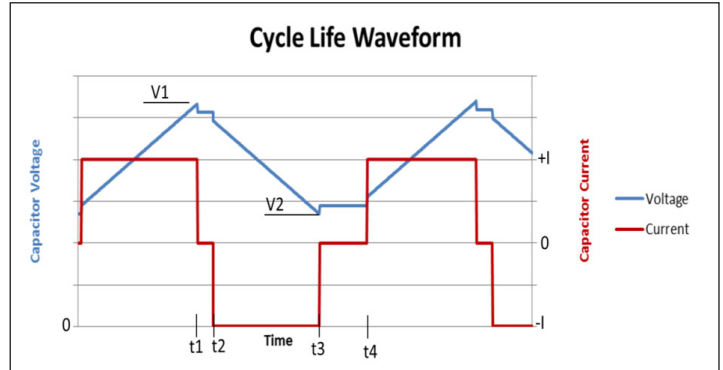

$V1 = V_{rated}$ $t2 - t1 = 5 \text{ seconds (I=0)}$
 $V2 = 0.5 \times V_{rated}$ $t4 - t3 = 15 \text{ seconds (I=0)}$

MOUNTING RECOMMENDATIONS

Please refer to the user manual for installation recommendations.

MARKINGS

Products are marked with the following information: Rated capacitance, rated voltage, product number, name of manufacturer, negative terminal, warning marking, serial number.

BCAP0001, 3, 5, 10, 25, 50, 100 (T01)

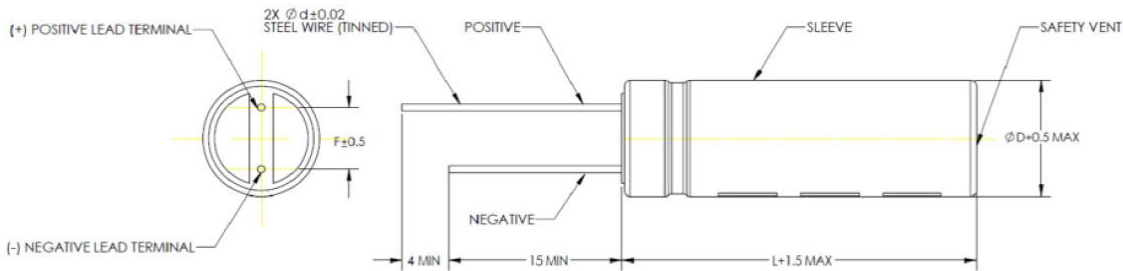

BCAP0010, 25 (T11)

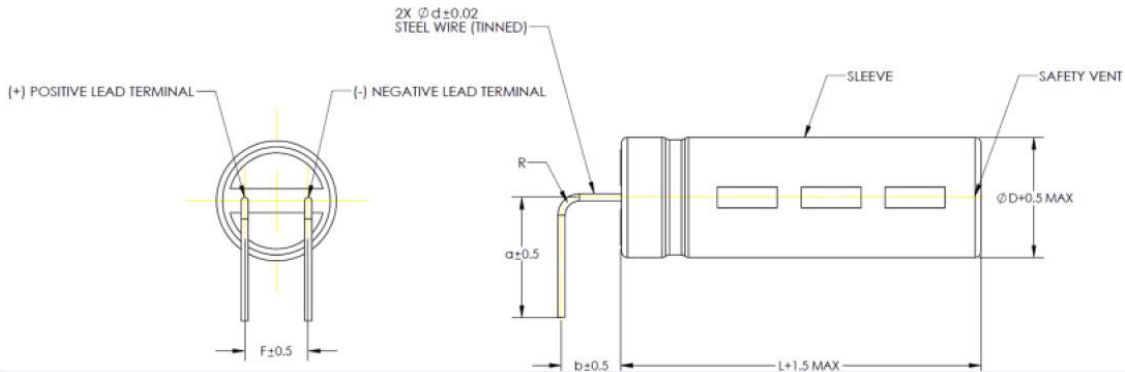

BCAP0010 (T12)

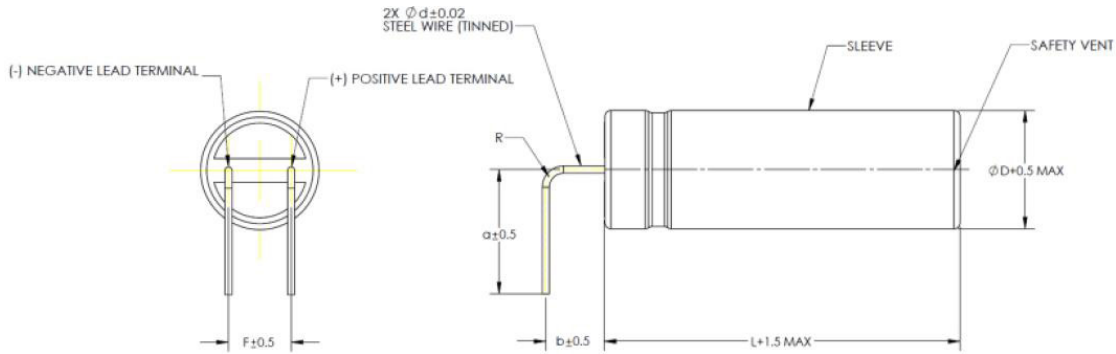

Product dimensions are for reference only unless otherwise identified. Product dimensions and specifications may change without notice. Please contact Maxwell Technologies directly for any technical specifications critical to application.

Part Description	Dimensions (mm)							Package Quantity
	L	D	d	F	R	a	b	
BCAP0001 P270 T01	12	8	0.6	3.8	-	-	-	4,000
BCAP0003 P270 T01	20	10	0.6	5	-	-	-	4,000
BCAP0005 P270 T01	20	10	0.6	5	-	-	-	4,000
BCAP0010 P270 T01	30	10	0.6	5	-	-	-	3,000
BCAP0010 P270 T11	30	10	0.6	5	1.5	10.5	5	1,600
BCAP0010 P270 T12	30	10	0.6	5	1.5	10.5	5	1,600
BCAP0025 P270 T01	26	16	0.8	7.5	-	-	-	1,300
BCAP0025 P270 T11	26	16	0.8	7.5	2	11.6	8.4	975
BCAP0050 P270 T01	40	18	0.8	7.5	-	-	-	800
BCAP0100 P270 T01	45	22	1	9.5	-	-	-	400

BCAP0100, 150 (T07)

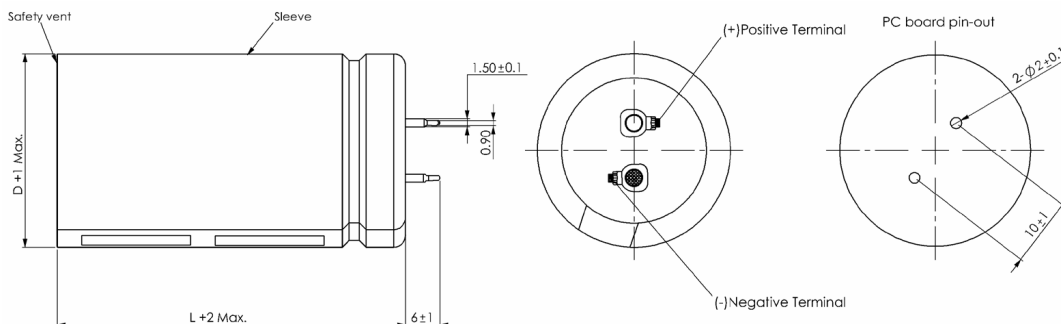

Part Description	Dimensions (mm)				Package Quantity
	L	D	d	F	
BCAP0100 P270 T07	45	22	-	-	400
BCAP0150 P270 T07	50	25	-	-	400

Product dimensions are for reference only unless otherwise identified. Product dimensions and specifications may change without notice. Please contact Maxwell Technologies directly for any technical specifications critical to application. All products featured on this datasheet are covered by the following U.S. patents and their respective foreign counterparts: 6525924, 6643119, 7295423, 7342770, 7352558, 7384433, 7492571, 7508651, 7791860, 7791861, 7883553, 7935155, 8072734, 8279580, and patents pending.



Maxwell Technologies, Inc.
Global Headquarters
 3888 Calle Fortunada
 San Diego, CA 92123
 USA
 Tel: +1 858 503 3300
 Fax: +1 858 503 3301



Maxwell Technologies SA
 Route de Montena 65
 CH-1728 Rossens
 Switzerland
 Tel: +41 (0)26 411 85 00
 Fax: +41 (0)26 411 85 05



Maxwell Technologies, GmbH
 Leopoldstrasse 244
 80807 München
 Germany
 Tel: +49 (0)89 / 4161403 0
 Fax: +49 (0)89 / 4161403 99



Maxwell Technologies Shanghai Trading Co. Ltd.
 Unit A2,C 12th Floor
 Huarun Times Square
 500 Zhangyang Road,
 Pudong New Area
 Shanghai 200122,
 P.R. China
 Phone: +86 21 3852 4000
 Fax: +86 21 3852 4099



Maxwell Technologies Korea Co., Ltd.
 Room 1524, D-Cube City
 Office Tower, 15F #662
 Gyeongin-Ro, Guro-Gu,
 Seoul, 152-706
 South Korea
 Phone: +82 10 4518 9829

MAXWELL TECHNOLOGIES, MAXWELL, MAXWELL CERTIFIED INTEGRATOR, ENABLING ENERGY'S FUTURE, BOOSTCAP, C CELL, D CELL and their respective designs and/or logos are either trademarks or registered trademarks of Maxwell Technologies, Inc. and may not be copied, imitated or used, in whole or in part, without the prior written permission Maxwell Technologies, Inc. All contents copyright © 2013 Maxwell Technologies, Inc. All rights reserved. No portion of these materials may be reproduced in any form, or by any means, without prior written permission from Maxwell Technologies, Inc.