

Series 84

Attractive. Versatile and functional.

<https://eao.com/84>



Key advantages

- Attractive design and reliable operation
- IP67 front protection
- Powerful, consistent illumination with innovative technologies
- Animated illumination options for a wide variety of potential applications
- Available with soldered, plug, PCB and flat ribbon cable terminals
- Freely configurable HMIs with IO-Link interface (Industry 4.0)

Typical application areas

- Machinery
- Measurement and control engineering
- Lifting and handling equipment
- Process automation
- Special vehicles
- Ticketing machines
- Medical equipment
- Food industry

Functions

- Pushbutton
- Illuminated pushbutton
- Indicator
- Capacitive buttons with IO-Link configurability

Design

- Flush
- Raised

IP front protection

- IP40
- IP65
- IP67
- IP69K

Ratings

- 42 VAC (100 mA)
- 240 VAC (1.5 A)
- 8.4 ... 32V (200 mA) electronic switching element

Mounting cut-outs

- Ø 22.3 mm
- Ø 22.5 mm
- Ø 30.5 mm

Terminal

- Soldering/plug-in terminal
- PCB
- Cable
- M12

Lens Material

- Aluminium
- Plastic
- Stainless steel

Markings

- Engraving
- Laser marking
- Hot stamping
- Pad printing
- Screen print
- Milling
- Illuminated Symbols

Approvals

- CB (IEC 60947)
- UL
- TSI PRM
- CSA
- EHEDG
- FDH Compliant
- CQC

Conformities

- CE
- UKCA
- 2006/42/EC (MD)
- 2011/65/EC (RoHS)
- 1300/2014 (PRM)
- 2014/30/EU (EMC)



Flush design	
Pushbutton standard	4
Pushbutton PCB standard	6
Pushbutton ring illumination standard	8
Pushbutton ring illumination PCB standard	9
Pushbutton ring illumination PCB	10
Pushbutton Halo Compact	11
Illuminated pushbutton standard	12
Illuminated pushbutton PCB standard	14
Indicator standard	16
Indicator PCB standard	17
Indicator ring illumination standard	18
Indicator ring illumination PCB standard	19
Indicator ring illumination PCB	20
Indicator Halo Compact	21
IO-Link Touch Standard	22
IO-Link Touch Stainless Steel	24
IO-Link Touch Hygiene	26
Raised design	
Stop switch	28
Emergency stop switch	31
Emergency stop switch, Bi-Colour	34
USB socket	36
Components	37
Accessories	52
Technical data	60
Application guidelines	66

84 Flush design

Pushbutton standard, IP40, IP67



Product can differ from the current configuration.

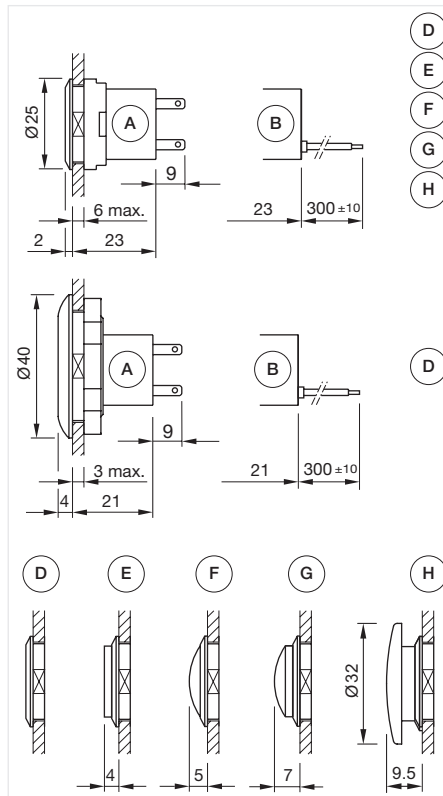

Dimensions [mm]
 A = Plug-in terminal 2.8 mm x 0.5 mm
 B = Flat ribbon cable
 D = Lens level with bezel
 E = Lens raised above bezel
 F = Lens konvexe level with bezel
 G = Lens konvexe raised above bezel
 H = Mushroom-head cap

Equipment consisting of (schematic overview)

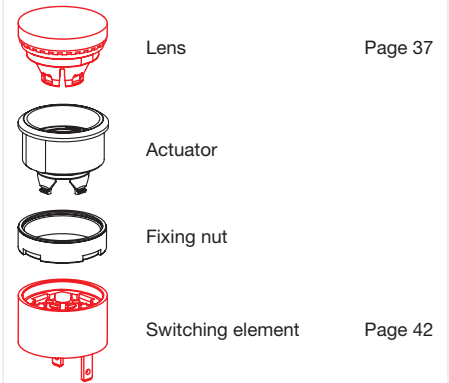

Each Part Number listed below includes all the black components shown in the 3D-drawing.

To obtain a complete unit, please select the red components from the pages shown.

General information

- Non-illuminated lens and bezel
- The colour of anodised aluminium parts can vary due to technical production reasons

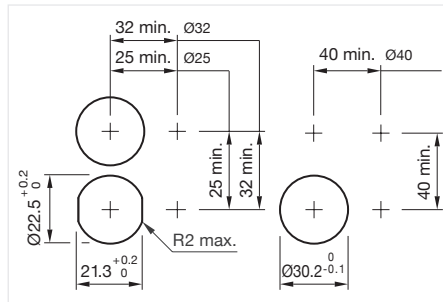

Mounting cut-outs [mm]



Actuator, Front dimension

Switching action	Front bezel colour	Front bezel material	IP front protection	Terminal	Dimension	Part No.	Wiring diagram
Momentary	Black	Plastic	IP67	null	Ø 25 mm	84-1101.0	72
	Black	Aluminium	IP67	null	Ø 25 mm	84-1201.0	72
	Red	Aluminium	IP67	null	Ø 25 mm	84-1201.2	72
	Gold	Aluminium	IP67	null	Ø 25 mm	84-1201.4	72
	Olive	Aluminium	IP67	null	Ø 25 mm	84-1201.5	72
	Blue	Aluminium	IP67	null	Ø 25 mm	84-1201.6	72
	Nature	Aluminium	IP67	null	Ø 25 mm	84-1201.7	72
	Black	Plastic	IP40	null	Ø 25 mm	84-2101.0	294



Actuator, Front dimension

Switching action	Front bezel colour	Front bezel material	IP front protection	Terminal	Dimension	Part No.	Wiring diagram
Momentary	Nature	Aluminium	IP67	null	Ø 40 mm	84-1221.7	294

Wiring diagrams

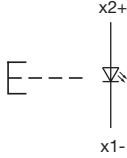
	
Wiring diagram 72	Wiring diagram 294

84 Flush design

Pushbutton PCB standard, IP40, IP67



Product can differ from the current configuration.

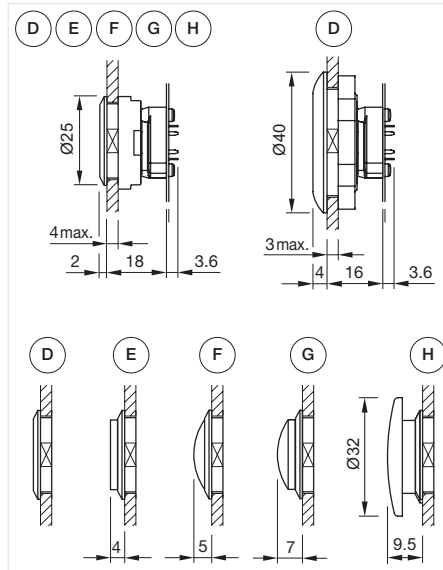

Dimensions [mm]
 D = Lens level with bezel
 E = Lens raised above bezel
 F = Lens konvexe level with bezel
 G = Lens konvexe raised above bezel
 H = Mushroom-head cap

Equipment consisting of (schematic overview)

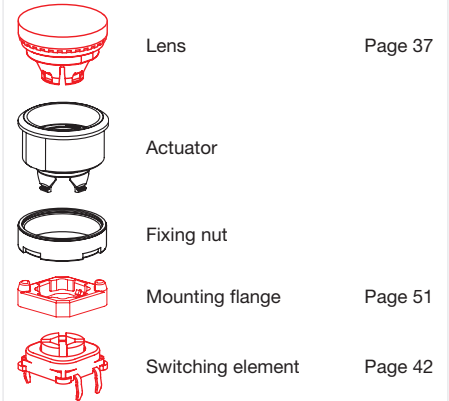

Each Part Number listed below includes all the black components shown in the 3D-drawing.

To obtain a complete unit, please select the red components from the pages shown.

General information

- Non-illuminated lens and bezel
- The colour of anodised aluminium parts can vary due to technical production reasons

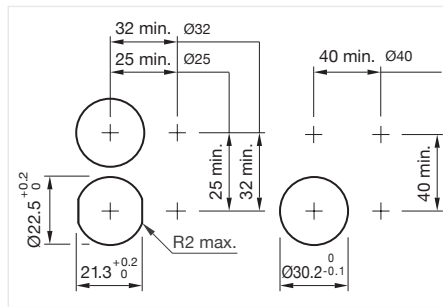

Mounting cut-outs [mm]



Actuator, Front dimension

Switching action	Front bezel colour	Front bezel material	IP front protection	Terminal	Dimension	Part No.	Wiring diagram
Momentary	Black	Plastic	IP67	null	Ø 25 mm	84-1101.0	72
	Black	Aluminium	IP67	null	Ø 25 mm	84-1201.0	72
	Red	Aluminium	IP67	null	Ø 25 mm	84-1201.2	72
	Gold	Aluminium	IP67	null	Ø 25 mm	84-1201.4	72
	Olive	Aluminium	IP67	null	Ø 25 mm	84-1201.5	72
	Blue	Aluminium	IP67	null	Ø 25 mm	84-1201.6	72
	Nature	Aluminium	IP67	null	Ø 25 mm	84-1201.7	72
	Black	Plastic	IP40	null	Ø 25 mm	84-2101.0	294



Actuator, Front dimension

Switching action	Front bezel colour	Front bezel material	IP front protection	Terminal	Dimension	Part No.	Wiring diagram
Momentary	Nature	Aluminium	IP67	null	Ø 40 mm	84-1221.7	294

Wiring diagrams

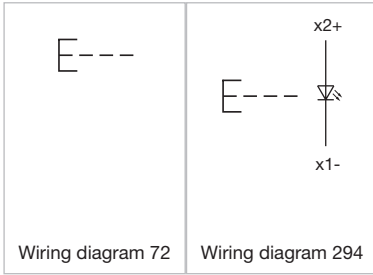

84 Flush design

Pushbutton ring illumination standard, IP67



Product can differ from the current configuration.

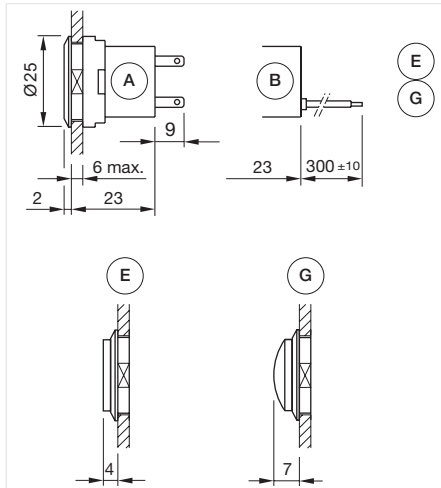

Dimensions [mm]
 A = Plug-in terminal 2.8 mm x 0.8 mm
 B = Flat ribbon cable
 E = Lens raised above bezel
 G = Lens convexe raised above bezel

Equipment consisting of (schematic overview)

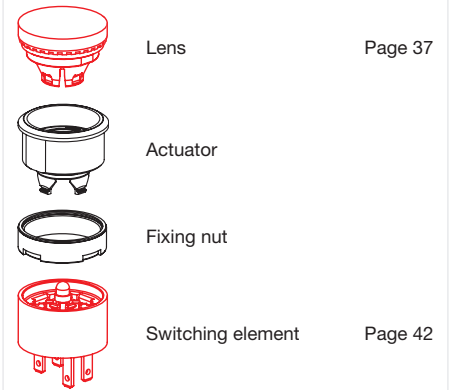

Each Part Number listed below includes all the black components shown in the 3D-drawing.

To obtain a complete unit, please select the red components from the pages shown.

General information

- Front bezel illuminated
- Accessories for halo illumination: Essential lenses Part No. 84-7202.x00A and 84-7205.x00A

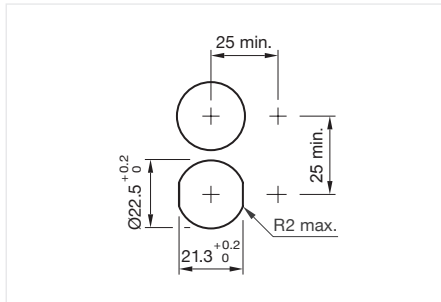

Mounting cut-outs [mm]



Actuator, Front dimension \varnothing 25 mm





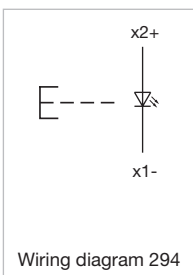

Switching action	Front bezel colour	Front bezel material	IP front protection	Terminal	Front bezel optics	Part No.	Wiring diagram
Momentary	White	Plastic	IP67	null	translucent	84-1091.7	294

Wiring diagrams



Pushbutton ring illumination PCB standard, IP67

Equipment consisting of (schematic overview)

	Lens	Page 37
	Actuator	
	Fixing nut	
	Mounting flange	Page 51
	Single-LED	Page 41
	Switching element	Page 42

Each Part Number listed below includes all the black components shown in the 3D-drawing.

To obtain a complete unit, please select the red components from the pages shown.

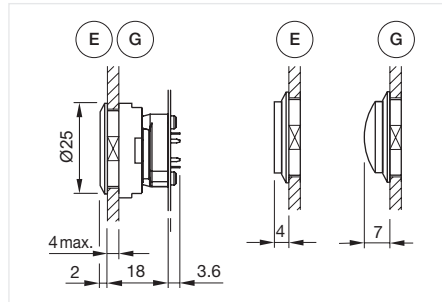

Dimensions [mm]
 E = Lens raised above bezel
 G = Lens convex raised above bezel



Product can differ from the current configuration.

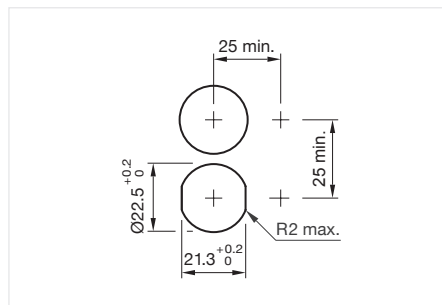

Mounting cut-outs [mm]

General information

- Front bezel illuminated
- Accessories for halo illumination: Essential lenses Part No. 84-7202.x00A and 84-7205.x00A



Actuator, Front dimension \varnothing 25 mm

Switching action	Front bezel colour	Front bezel material	IP front protection	Terminal	Front bezel optics	Part No.	Wiring diagram
Momentary	White	Plastic	IP67	null	translucent	84-1091.7	294

Wiring diagrams

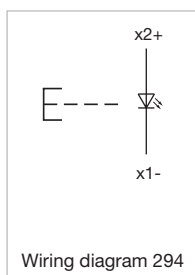

84 Flush design

Pushbutton ring illumination PCB, IP67



Product can differ from the current configuration.

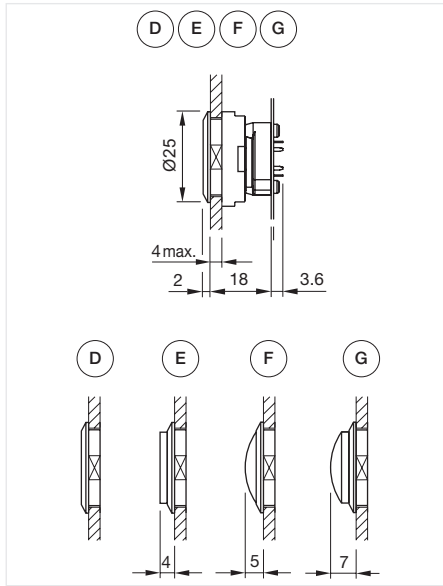

Dimensions [mm]
 D = Lens level with bezel
 E = Lens raised above bezel
 F = Lens konvexe level with bezel
 G = Lens konvexe raised above bezel

Equipment consisting of (schematic overview)

	Lens	Page 37
	Actuator	
	Fixing nut	
	Mounting flange	Page 51
	Single-LED	Page 41
	Switching element	Page 42

Each Part Number listed below includes all the black components shown in the 3D-drawing.

To obtain a complete unit, please select the red components from the pages shown.

General information

- The mini TOP LEDs are not part of delivery. Recommendation: Osram Hyper Mini TOP LED

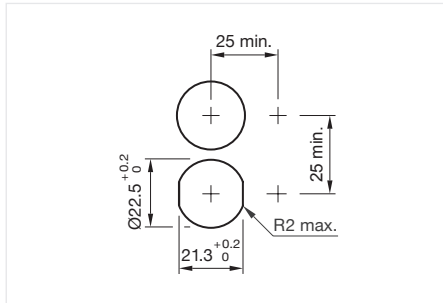

Mounting cut-outs [mm]



Actuator, Front dimension Ø 25 mm

Switching action	Front bezel colour	Front bezel material	IP front protection	Terminal	Front bezel optics	Part No.	Wiring diagram
Momentary	Colourless	Plastic	IP67	null	transparent	84-1081.7	294

Wiring diagrams

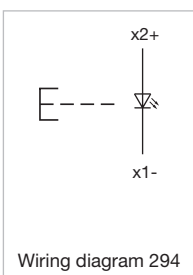

Pushbutton Halo Compact, IP67

Equipment consisting of (schematic overview)



Lens

Page 37



Actuator



Fixing nut



Switching element

Page 42

Each Part Number listed below includes all the black components shown in the 3D-drawing.

To obtain a complete unit, please select the red components from the pages shown.

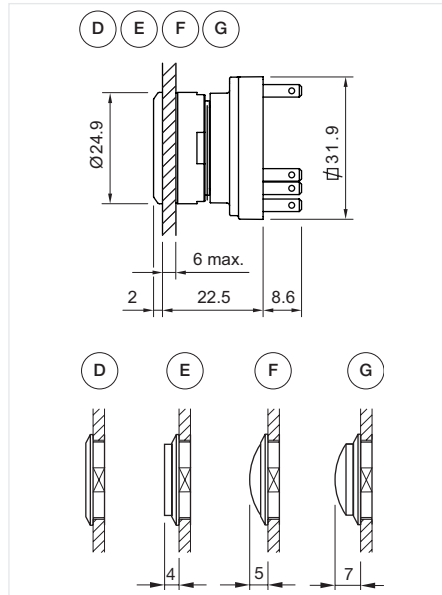

Dimensions [mm]



Product can differ from the current configuration.

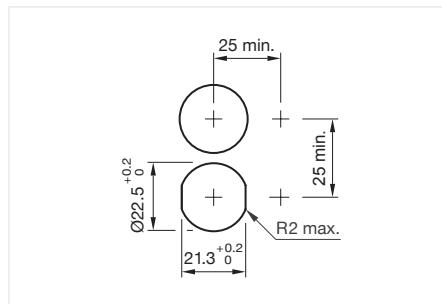

Mounting cut-outs [mm]

General information

- The mini TOP LEDs are not part of delivery. Recommendation: Osram Hyper Mini TOP LED



Actuator, Front dimension Ø 25 mm

Switching action	Front bezel colour	Front bezel material	IP front protection	Terminal	Front bezel optics	Part No.	Wiring diagram
Momentary	Colourless	Plastic	IP67	null	transparent	84-1081.7	294

Wiring diagrams

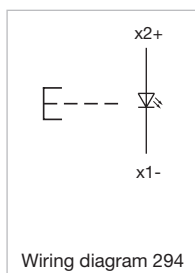

84 Flush design

Illuminated pushbutton standard, IP40, IP67



Product can differ from the current configuration.

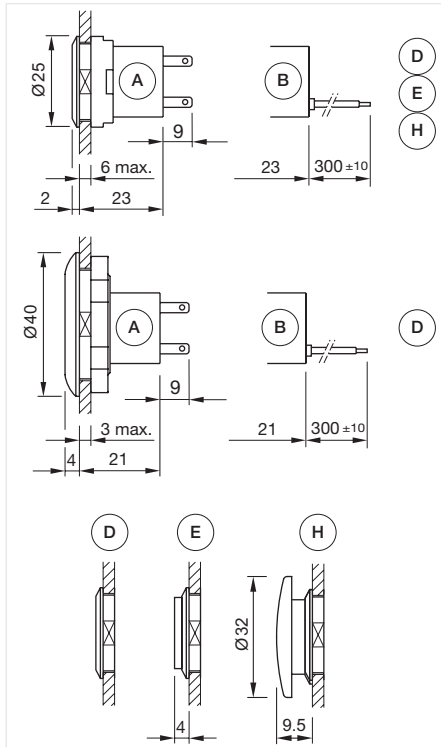

Dimensions [mm]
 A = Plug-in terminal 2.8 mm x 0.8 mm
 B = Flat ribbon cable
 D = Lens level with bezel
 E = Lens raised above bezel
 H = Mushroom-head cap

Equipment consisting of (schematic overview)

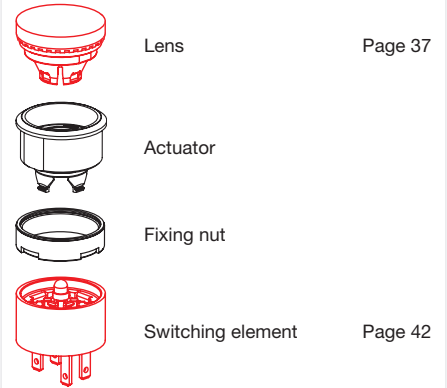

Each Part Number listed below includes all the black components shown in the 3D-drawing.

To obtain a complete unit, please select the red components from the pages shown.

General information

- Illuminated lens, non-illuminated bezel
- The colour of anodised aluminium parts can vary due to technical production reasons

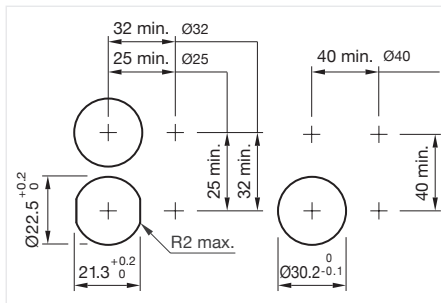

Mounting cut-outs [mm]



Actuator, Front dimension

Switching action	Front bezel colour	Front bezel material	IP front protection	Terminal	Dimension	Part No.	Wiring diagram
Momentary	Black	Plastic	IP67	null	$\varnothing 25$ mm	84-1101.0	72
	Black	Aluminium	IP67	null	$\varnothing 25$ mm	84-1201.0	72
	Red	Aluminium	IP67	null	$\varnothing 25$ mm	84-1201.2	72
	Gold	Aluminium	IP67	null	$\varnothing 25$ mm	84-1201.4	72
	Olive	Aluminium	IP67	null	$\varnothing 25$ mm	84-1201.5	72
	Blue	Aluminium	IP67	null	$\varnothing 25$ mm	84-1201.6	72
	Nature	Aluminium	IP67	null	$\varnothing 25$ mm	84-1201.7	72
	Black	Plastic	IP40	null	$\varnothing 25$ mm	84-2101.0	294



Actuator, Front dimension

Switching action	Front bezel colour	Front bezel material	IP front protection	Terminal	Dimension	Part No.	Wiring diagram
Momentary	Nature	Aluminium	IP67	null	Ø 40 mm	84-1221.7	294

Wiring diagrams

Wiring diagram 72	Wiring diagram 294

84 Flush design

Illuminated pushbutton PCB standard, IP40, IP67



Product can differ from the current configuration.

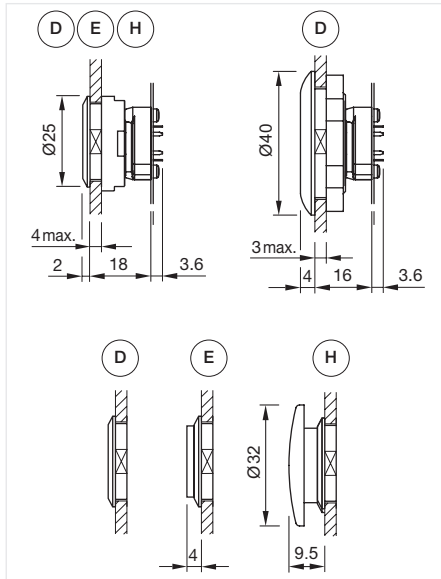

Dimensions [mm]
 A = Lens level with bezel
 E = Lens raised above bezel
 H = Mushroom-head cap

Equipment consisting of (schematic overview)

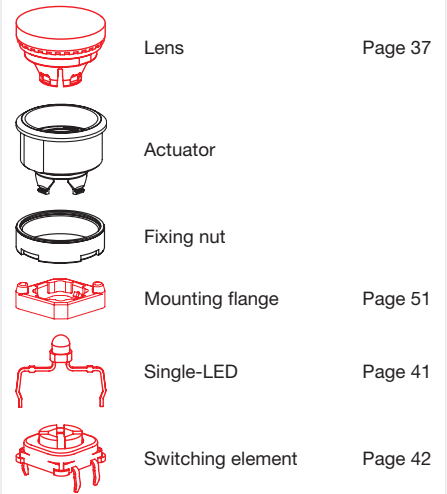

Each Part Number listed below includes all the black components shown in the 3D-drawing.

To obtain a complete unit, please select the red components from the pages shown.

General information

- Illuminated lens, non-illuminated bezel
- The colour of anodised aluminium parts can vary due to technical production reasons

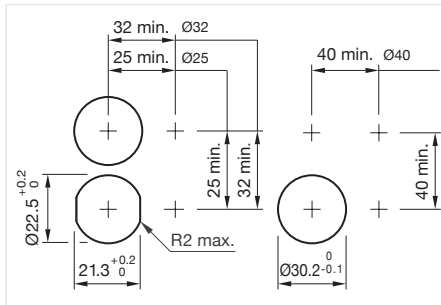

Mounting cut-outs [mm]



Actuator, Front dimension

Switching action	Front bezel colour	Front bezel material	IP front protection	Terminal	Dimension	Part No.	Wiring diagram
Momentary	Black	Plastic	IP67	null	$\varnothing 25$ mm	84-1101.0	72
	Black	Aluminium	IP67	null	$\varnothing 25$ mm	84-1201.0	72
	Red	Aluminium	IP67	null	$\varnothing 25$ mm	84-1201.2	72
	Gold	Aluminium	IP67	null	$\varnothing 25$ mm	84-1201.4	72
	Olive	Aluminium	IP67	null	$\varnothing 25$ mm	84-1201.5	72
	Blue	Aluminium	IP67	null	$\varnothing 25$ mm	84-1201.6	72
	Nature	Aluminium	IP67	null	$\varnothing 25$ mm	84-1201.7	72
	Black	Plastic	IP40	null	$\varnothing 25$ mm	84-2101.0	294



Actuator, Front dimension

Switching action	Front bezel colour	Front bezel material	IP front protection	Terminal	Dimension	Part No.	Wiring diagram
Momentary	Nature	Aluminium	IP67	null	$\varnothing 40$ mm	84-1221.7	294

Wiring diagrams

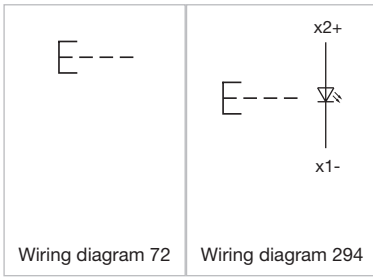

84 Flush design

Indicator standard, IP40, IP67



Product can differ from the current configuration.

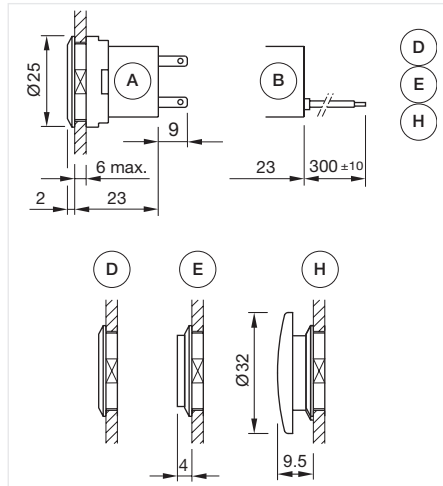

Dimensions [mm]
 A = Plug-in terminal 2.8 mm x 0.8 mm
 B = Flat ribbon cable
 D = Lens level with bezel
 E = Lens raised above bezel
 H = Mushroom-head cap

Equipment consisting of (schematic overview)

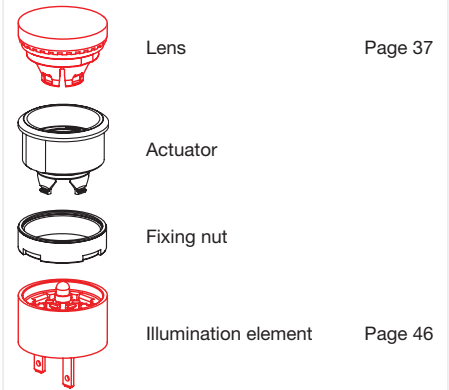

Each Part Number listed below includes all the black components shown in the 3D-drawing.

To obtain a complete unit, please select the red components from the pages shown.

General information

- Illuminated lens, non-illuminated bezel
- The colour of anodised aluminium parts can vary due to technical production reasons

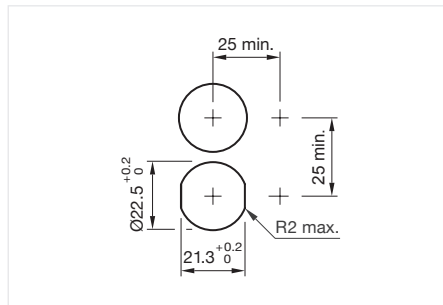

Mounting cut-outs [mm]



Actuator, Front dimension \varnothing 25 mm





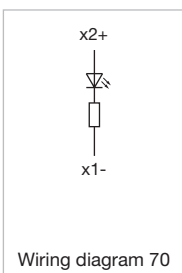

IP front protection	Front bezel colour	Front bezel material	Part No.	Wiring diagram
IP67	Black	Plastic	84-0100.0	70
	Nature	Aluminium	84-0200.7	70
IP40	Black	Plastic	84-3100.0	70

Wiring diagrams



Indicator PCB standard, IP40, IP67

Equipment consisting of (schematic overview)

	Lens	Page 37
	Actuator	
	Fixing nut	
	Mounting flange	Page 51
	Single-LED	Page 41
	Illumination element	Page 46

Each Part Number listed below includes all the black components shown in the 3D-drawing.

To obtain a complete unit, please select the red components from the pages shown.

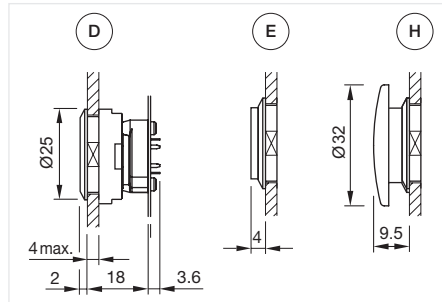

Dimensions [mm]
 A = Lens level with bezel
 E = Lens raised above bezel
 H = Mushroom-head cap

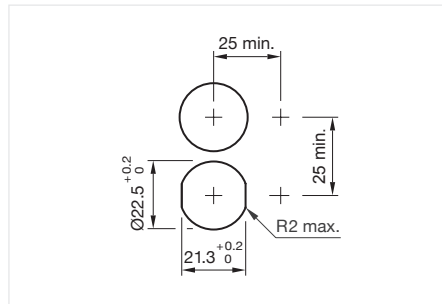

Mounting cut-outs [mm]



Product can differ from the current configuration.

General information

- Illuminated lens, non-illuminated bezel
- The colour of anodised aluminium parts can vary due to technical production reasons



Actuator, Front dimension $\text{Ø} 25 \text{ mm}$

IP front protection	Front bezel colour	Front bezel material	Part No.	Wiring diagram
IP67	Black	Plastic	84-0100.0	70
	Nature	Aluminium	84-0200.7	70
IP40	Black	Plastic	84-3100.0	70

Wiring diagrams

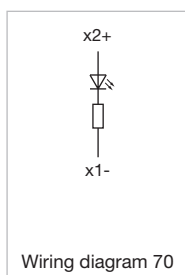

Wiring diagram 70

84 Flush design

Indicator ring illumination standard, IP67



Product can differ from the current configuration.

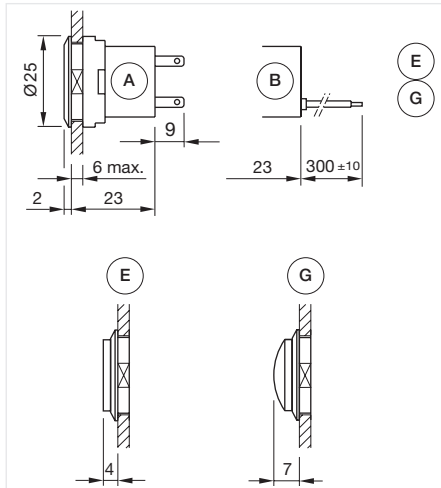

Dimensions [mm]
 A = Plug-in terminal 2.8 mm x 0.8 mm
 B = Flat ribbon cable
 E = Lens raised above bezel
 G = Lens convexe raised above bezel

Equipment consisting of (schematic overview)

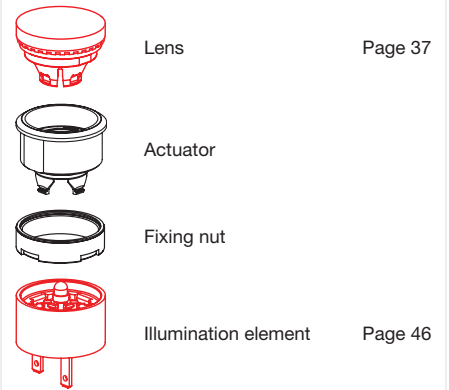

Each Part Number listed below includes all the black components shown in the 3D-drawing.

To obtain a complete unit, please select the red components from the pages shown.

General information

- Front bezel illuminated

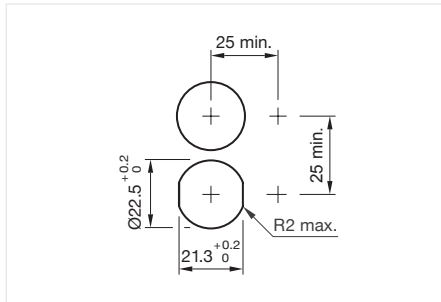

Mounting cut-outs [mm]



Actuator, Front dimension \varnothing 25 mm





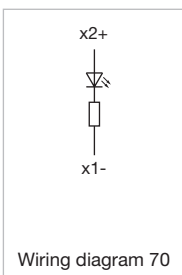

IP front protection	Front bezel colour	Front bezel material	Front bezel optics	Part No.	Wiring diagram
IP67	Colourless	Plastic	translucent	84-0090.7	70

Wiring diagrams



Indicator ring illumination PCB standard, IP67

Equipment consisting of (schematic overview)

	Lens	Page 37
	Actuator	
	Fixing nut	
	Mounting flange	Page 51
	Single-LED	Page 41
	Illumination element	Page 46

Each Part Number listed below includes all the black components shown in the 3D-drawing.

To obtain a complete unit, please select the red components from the pages shown.

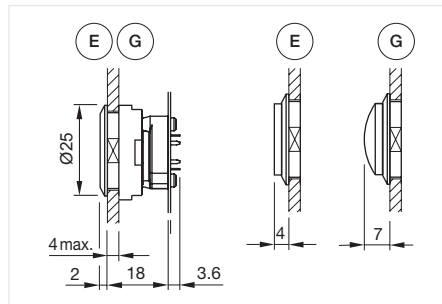

Dimensions [mm]
 E = Lens raised above bezel
 G = Lens convex raised above bezel



Product can differ from the current configuration.

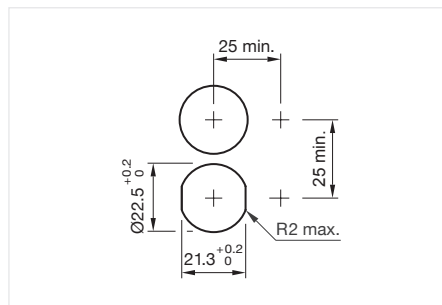

Mounting cut-outs [mm]

General information

- Front bezel illuminated
- Accessories for halo illumination: Essential lenses Part No. 84-7202.x00A and 84-7205.x00A



Actuator, Front dimension Ø 25 mm

IP front protection	Front bezel colour	Front bezel material	Front bezel optics	Part No.	Wiring diagram
IP67	Colourless	Plastic	translucent	84-0090.7	70

Wiring diagrams

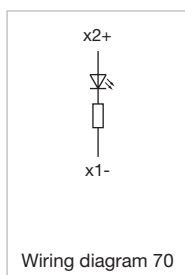

84 Flush design

Indicator ring illumination PCB, IP67



Product can differ from the current configuration.

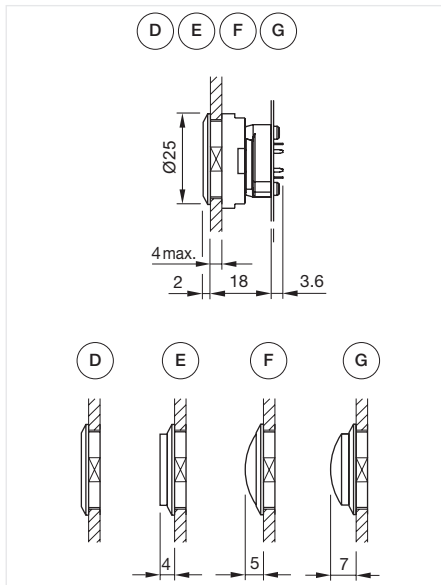

Dimensions [mm]
 D = Lens level with bezel
 E = Lens raised above bezel
 F = Lens konvexe level with bezel
 G = Lens konvexe raised above bezel

Equipment consisting of (schematic overview)

	Lens	Page 37
	Actuator	
	Fixing nut	
	Mounting flange	Page 51
	Single-LED	Page 41
	Illumination element	Page 46

Each Part Number listed below includes all the black components shown in the 3D-drawing.

To obtain a complete unit, please select the red components from the pages shown.

General information

- The mini TOP LEDs are not part of delivery. Recommendation: Osram Hyper Mini TOP LED

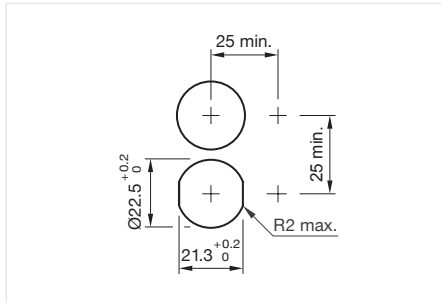

Mounting cut-outs [mm]



Actuator, Front dimension $\varnothing 25$ mm

IP front protection	Front bezel colour	Front bezel material	Front bezel optics	Part No.	Wiring diagram
IP67	Colourless	Plastic	transparent	84-0080.7	70

Wiring diagrams

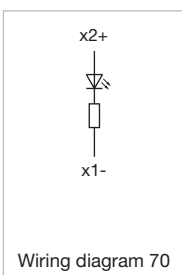

Wiring diagram 70

Indicator Halo Compact, IP67

Equipment consisting of (schematic overview)



Lens

Page 37



Actuator



Fixing nut



Switching element

Page 42

Each Part Number listed below includes all the black components shown in the 3D-drawing.

To obtain a complete unit, please select the red components from the pages shown.

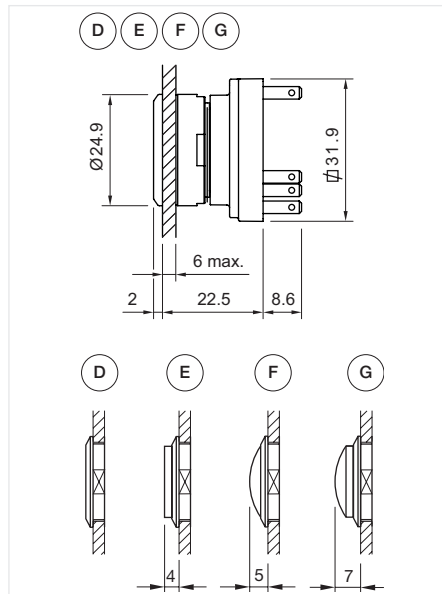

Dimensions [mm]



Product can differ from the current configuration.

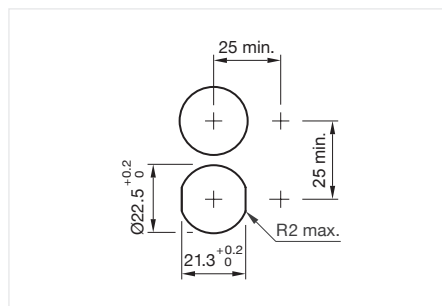

Mounting cut-outs [mm]

General information

- The mini TOP LEDs are not part of delivery. Recommendation: Osram Hyper Mini TOP LED



Actuator, Front dimension Ø 25 mm

IP front protection	Front bezel colour	Front bezel material	Front bezel optics	Part No.	Wiring diagram
IP67	Colourless	Plastic	transparent	84-0080.7	70

Wiring diagrams

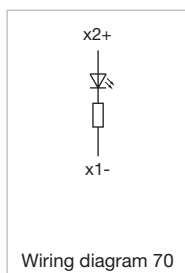

84 Flush design

IO-Link Touch Standard, IP69K



Product can differ from the current configuration.

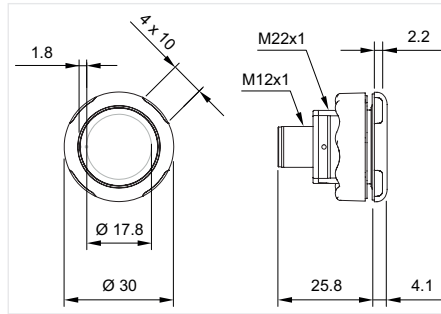

Dimensions [mm]

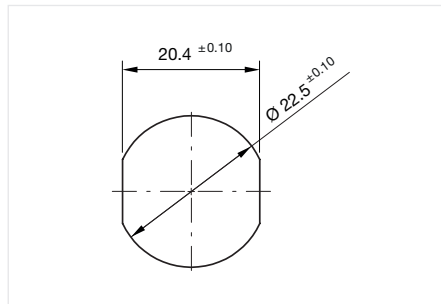

Mounting cut-outs [mm]

Equipment consisting of (schematic overview)

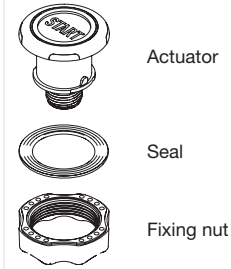

Each Part Number listed below includes all the black components shown in the 3D-drawing.



IO-Link Touch Standard

Front bezel material	Output	Output pulse	LED control	LED colour 1	LED colour 2	Symbol	Part No.
Plastic	PNP/NPN; NO/NC	Dynamic	Automatic	Green	Red	START (B10)	84-ASKS-B10-049C
	PNP/NPN; NO/NC	Dynamic	Automatic	Green	Red	STOP (B11)	84-ASKS-B11-049D
	PNP/NPN; NO/NC	Dynamic	Automatic	Green	Red	ON/OFF (B12)	84-ASKS-B12-049E
	PNP/NPN; NO/NC	Dynamic	Automatic	Green	Red	RESET (B13)	84-ASKS-B13-049F
	PNP/NPN; NO/NC	Dynamic	Automatic	Green	Red	Standby (B14)	84-ASKS-B14-04A0
	PNP/NPN; NO/NC	Dynamic	Automatic	Green	Red	arrows (B15)	84-ASKS-B15-04A1
	PNP/NPN; NO/NC	Dynamic	Automatic	Green	Red	START (C10)	84-ASKS-C10-04A2
	PNP/NPN; NO/NC	Dynamic	Automatic	Green	Red	STOP (C11)	84-ASKS-C11-04A3
	PNP/NPN; NO/NC	Dynamic	Automatic	Green	Red	ON/OFF (C12)	84-ASKS-C12-04A4
	PNP/NPN; NO/NC	Dynamic	Automatic	Green	Red	Standby (C14)	84-ASKS-C14-04A5
	PNP/NPN; NO/NC	Dynamic	Automatic	Green	Red	Standby (C16)	84-ASKS-C16-04A6
	PNP/NPN; NO/NC	Dynamic	Automatic	Green	Red	START (C17)	84-ASKS-C17-04A7
	PNP/NPN; NO/NC	Dynamic	Automatic	Green	Red	STOP (C18)	84-ASKS-C18-04A8
	PNP/NPN; NO/NC	Dynamic	Automatic	Green	Red	RESET (C19)	84-ASKS-C19-04A9
	PNP/NPN; NO/NC	Dynamic	Automatic	Green	Red	C20	84-ASKS-C20-049B

Wiring diagrams

3-pole

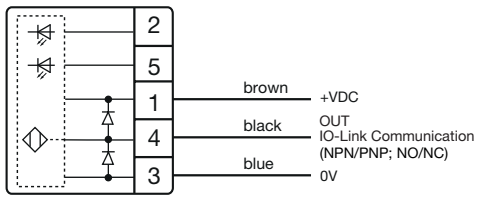

Wiring diagram

4-pole

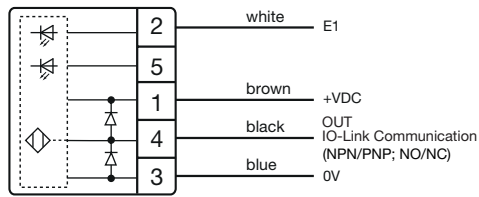

Wiring diagram

5-pole

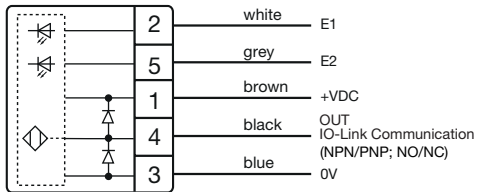

Wiring diagram

Component layouts

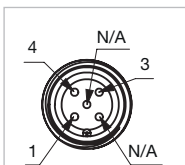

Component layout

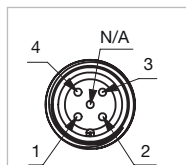

Component layout

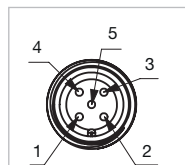

Component layout

84 Flush design

IO-Link Touch Stainless Steel, IP69K



Product can differ from the current configuration.

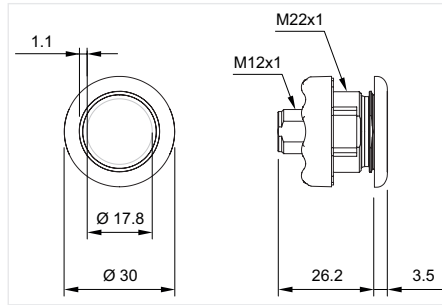

Dimensions [mm]

Equipment consisting of (schematic overview)

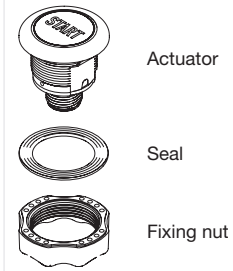

Each Part Number listed below includes all the black components shown in the 3D-drawing.

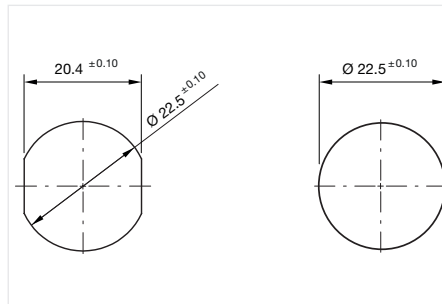

Mounting cut-outs [mm]



IO-Link Touch Stainless Steel

Front bezel material	Output	Output pulse	LED control	LED colour 1	LED colour 2	Symbol	Part No.
Plastic	PNP/NPN; NO/NC	Dynamic	Automatic	Green	Red	START (B10)	84-ADKS-B10-04AA
	PNP/NPN; NO/NC	Dynamic	Automatic	Green	Red	STOP (B11)	84-ADKS-B11-04AB
	PNP/NPN; NO/NC	Dynamic	Automatic	Green	Red	ON/OFF (B12)	84-ADKS-B12-04AC
	PNP/NPN; NO/NC	Dynamic	Automatic	Green	Red	RESET (B13)	84-ADKS-B13-04AD
	PNP/NPN; NO/NC	Dynamic	Automatic	Green	Red	Standby (B14)	84-ADKS-B14-04AE
	PNP/NPN; NO/NC	Dynamic	Automatic	Green	Red	arrows (B15)	84-ADKS-B15-04AF
	PNP/NPN; NO/NC	Dynamic	Automatic	Green	Red	START (C10)	84-ADKS-C10-04B0
	PNP/NPN; NO/NC	Dynamic	Automatic	Green	Red	STOP (C11)	84-ADKS-C11-04B1
	PNP/NPN; NO/NC	Dynamic	Automatic	Green	Red	ON/OFF (C12)	84-ADKS-C12-04B2
	PNP/NPN; NO/NC	Dynamic	Automatic	Green	Red	Standby (C14)	84-ADKS-C14-04B3
	PNP/NPN; NO/NC	Dynamic	Automatic	Green	Red	START (B10)	84-ADKS-C16-04B4
	PNP/NPN; NO/NC	Dynamic	Automatic	Green	Red	START (C17)	84-ADKS-C17-04B5
	PNP/NPN; NO/NC	Dynamic	Automatic	Green	Red	STOP (C18)	84-ADKS-C18-04B6
	PNP/NPN; NO/NC	Dynamic	Automatic	Green	Red	RESET (C19)	84-ADKS-C19-04B7
	PNP/NPN; NO/NC	Dynamic	Automatic	Green	Red	C20	84-ADKS-C20-04B8

Wiring diagrams

3-pole

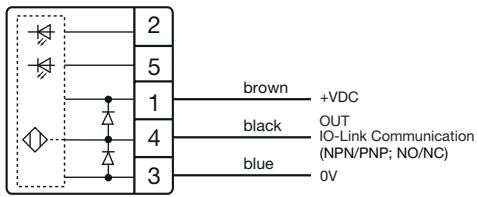

Wiring diagram

4-pole

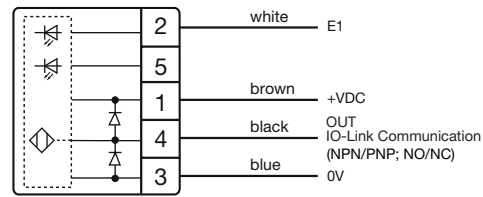

Wiring diagram

5-pole

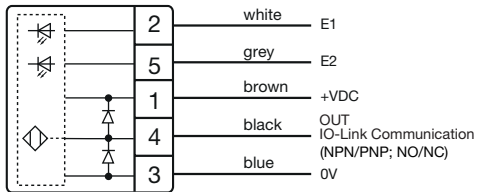

Wiring diagram

Component layouts

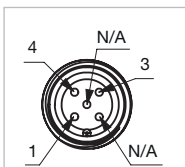

Component layout

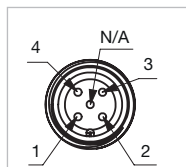

Component layout

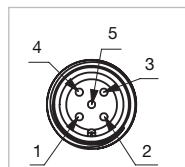

Component layout

84 Flush design

IO-Link Touch Hygiene, IP69K



Product can differ from the current configuration.

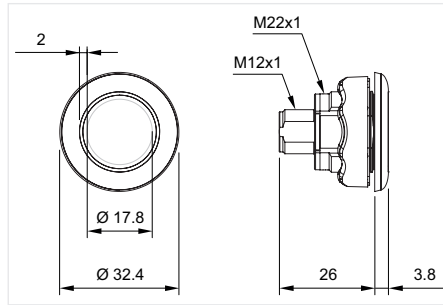

Dimensions [mm]

Equipment consisting of (schematic overview)

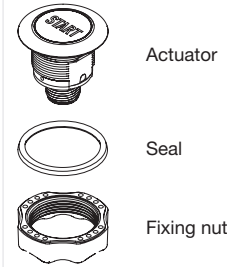

Each Part Number listed below includes all the black components shown in the 3D-drawing.

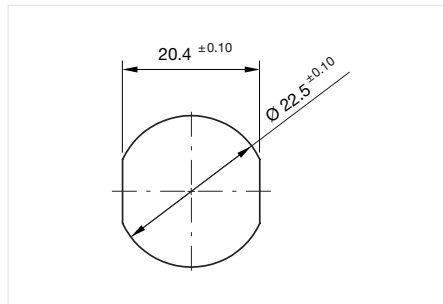

Mounting cut-outs [mm]



IO-Link Touch Hygiene

Front bezel material	Output	Output pulse	LED control	LED colour 1	LED colour 2	Symbol	Part No.
Plastic	PNP/NPN; NO/NC	Dynamic	Automatic	Green	Red	START (B10)	84-ACKS-B10-04B9
	PNP/NPN; NO/NC	Dynamic	Automatic	Green	Red	STOP (B11)	84-ACKS-B11-04BA
	PNP/NPN; NO/NC	Dynamic	Automatic	Green	Red	ON/OFF (B12)	84-ACKS-B12-04BB
	PNP/NPN; NO/NC	Dynamic	Automatic	Green	Red	RESET (B13)	84-ACKS-B13-04BC
	PNP/NPN; NO/NC	Dynamic	Automatic	Green	Red	Standby (B14)	84-ACKS-B14-04BD
	PNP/NPN; NO/NC	Dynamic	Automatic	Green	Red	arrows (B15)	84-ACKS-B15-04BE
	PNP/NPN; NO/NC	Dynamic	Automatic	Green	Red	START (C10)	84-ACKS-C10-04BF
	PNP/NPN; NO/NC	Dynamic	Automatic	Green	Red	STOP (C11)	84-ACKS-C11-04C0
	PNP/NPN; NO/NC	Dynamic	Automatic	Green	Red	ON/OFF (C12)	84-ACKS-C12-04C1
	PNP/NPN; NO/NC	Dynamic	Automatic	Green	Red	Standby (C14)	84-ACKS-C14-04C2
	PNP/NPN; NO/NC	Dynamic	Automatic	Green	Red	Standby (C16)	84-ACKS-C16-04C3
	PNP/NPN; NO/NC	Dynamic	Automatic	Green	Red	START (C17)	84-ACKS-C17-04C4
	PNP/NPN; NO/NC	Dynamic	Automatic	Green	Red	STOP (C18)	84-ACKS-C18-04C5
	PNP/NPN; NO/NC	Dynamic	Automatic	Green	Red	RESET (C19)	84-ACKS-C19-04C6
	PNP/NPN; NO/NC	Dynamic	Automatic	Green	Red	C20	84-ACKS-C20-04C7

Wiring diagrams

3-pole

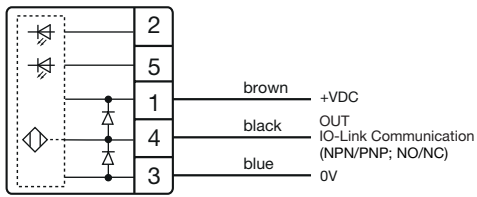

4-pole

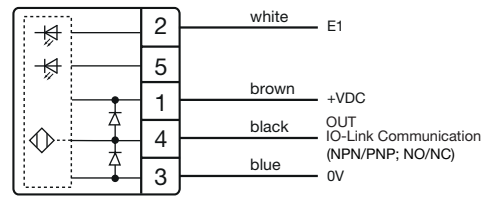

5-pole

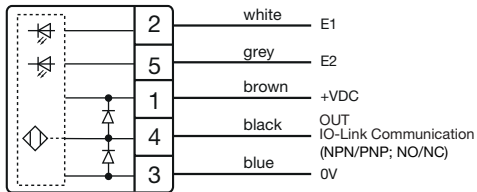

Component layouts

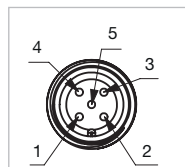
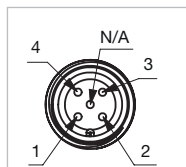
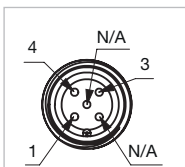

84 Raised design

Stop switch, IP65, IP66, IP67



Product can differ from the current configuration.

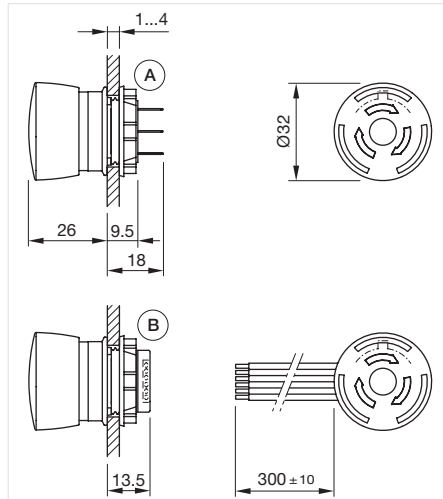

Dimensions [mm]
 A = Plug-in terminal 2.8 mm x 0.5 mm
 B = Flat ribbon cable

Equipment consisting of (schematic overview)

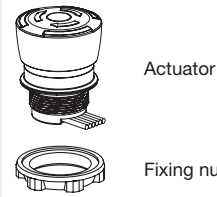

Each Part Number listed below includes all the black components shown in the 3D-drawing.

General information

- Position indication ring black
- Lens plastic grey

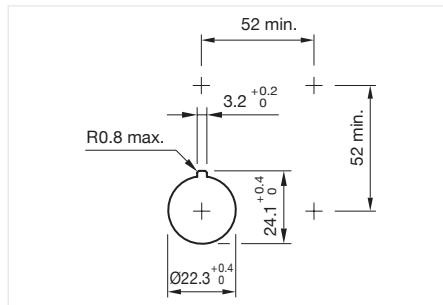

Mounting cut-outs [mm]



Stop switch, Front dimension Ø 32 mm

Switching action	Contacts	Terminal	Lens colour	Illumination colour	Product attributes	Switching position ring	Part No.	Wiring diagram	Component Layout
Maintained	1 NC	Plug-in terminal, 2.8 x 0.5 mm	Grey		Twist to unlock clockwise	Black	84-6220.0020	345	99
	1 NC	Flat ribbon cable 300 mm	Grey		Twist to unlock clockwise	Black	84-6220.0040	426	98
	1 NC	Plug-in terminal, 2.8 x 0.5 mm	Grey	Red	Twist to unlock clockwise	Black	84-6221.2B20	348	99
	1 NC	Flat ribbon cable 300 mm	Grey	Red	Twist to unlock clockwise	Black	84-6221.2B40	429	98
	1 NC / 1 NO	Plug-in terminal, 2.8 x 0.5 mm	Grey		Twist to unlock clockwise	Black	84-6230.0020	346	99
	1 NC / 1 NO	Flat ribbon cable 300 mm	Grey		Twist to unlock clockwise	Black	84-6230.0040	427	98
	1 NC / 1 NO	Plug-in terminal, 2.8 x 0.5 mm	Grey	Red	Twist to unlock clockwise	Black	84-6231.2B20	349	99
	1 NC / 1 NO	Flat ribbon cable 300 mm	Grey	Red	Twist to unlock clockwise	Black	84-6231.2B40	431	98
	2 NC	Plug-in terminal, 2.8 x 0.5 mm	Grey		Twist to unlock clockwise	Black	84-6240.0020	347	99
	2 NC	Flat ribbon cable 300 mm	Grey	none	Twist to unlock clockwise	Black	84-6240.0040	428	98
2 NC	Plug-in terminal, 2.8 x 0.5 mm	Grey	Red	Twist to unlock clockwise	Black	84-6241.2B20	350	99	

Contacts: NC = Normally closed, NO = Normally open

Switching action	Contacts	Terminal	Lens colour	Illumination colour	Product attributes	Switching position ring	Part No.	Wiring diagram	Component Layout
Maintained	2 NC	Flat ribbon cable 300 mm	Grey	Red	Twist to unlock clockwise	Black	84-6241.2B40	430	98
	1 NC / 1 NO	Flat ribbon cable 300 mm	Black	none	Twist to unlock clockwise	Black	84-6330.0040	427	98
	1 NC / 1 NO	Plug-in terminal, 2.8 x 0.5 mm	Black	Red	Twist to unlock clockwise	Black	84-6331.2B20	349	99
	1 NC / 1 NO	Flat ribbon cable 300 mm	Black	Red	Twist to unlock clockwise	Black	84-6331.2B40	431	98
	2 NC	Flat ribbon cable 300 mm	Black	none	Twist to unlock clockwise	Black	84-6340.0040	428	98
	2 NC	Plug-in terminal, 2.8 x 0.5 mm	Black	Red	Twist to unlock clockwise	Black	84-6341.2B20	350	99
	2 NC	Flat ribbon cable 300 mm	Black	Red	Twist to unlock clockwise	Black	84-6341.2B40	430	98

Contacts: NC = Normally closed, NO = Normally open

Wiring diagrams

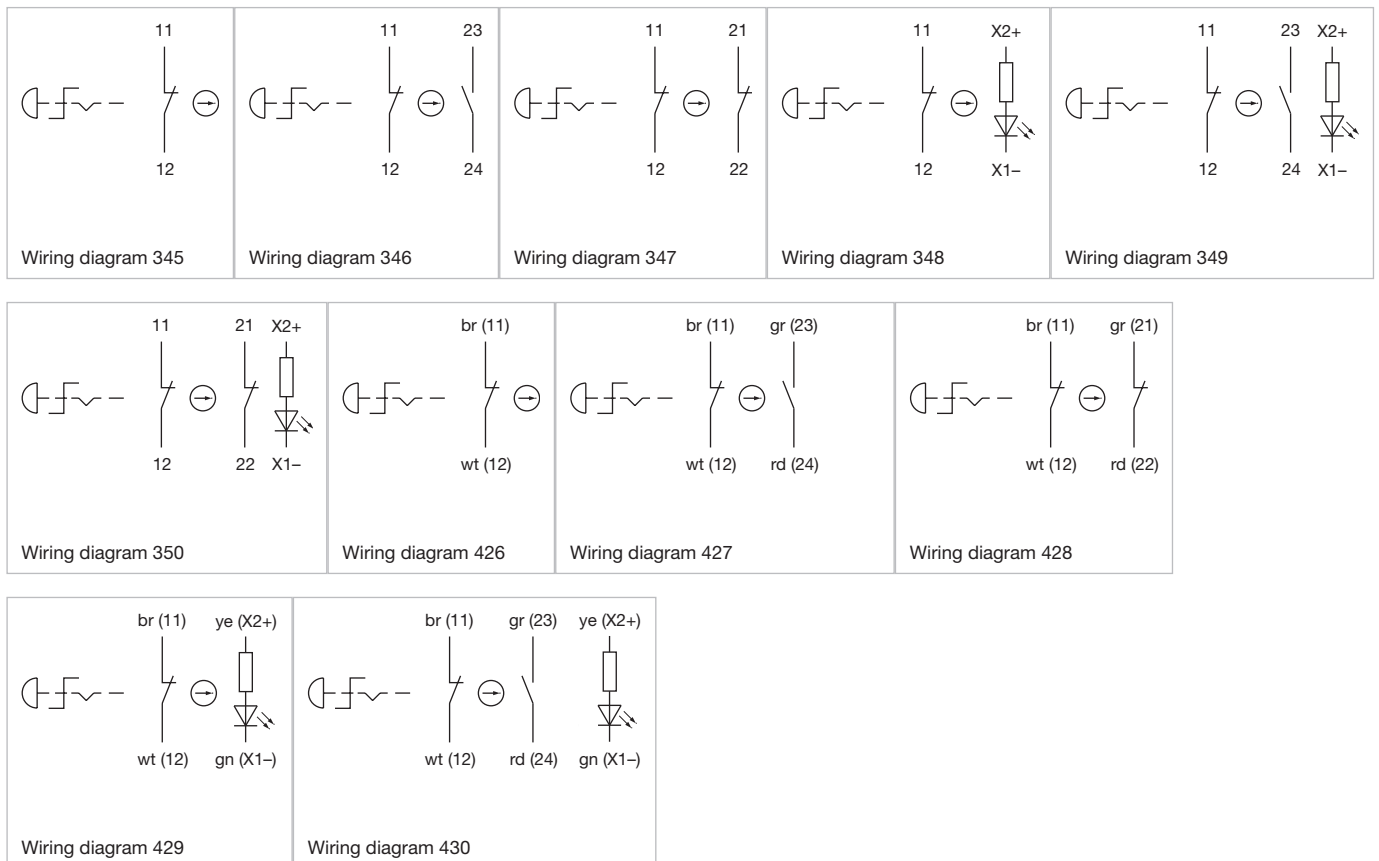

84 Raised design

Component layouts

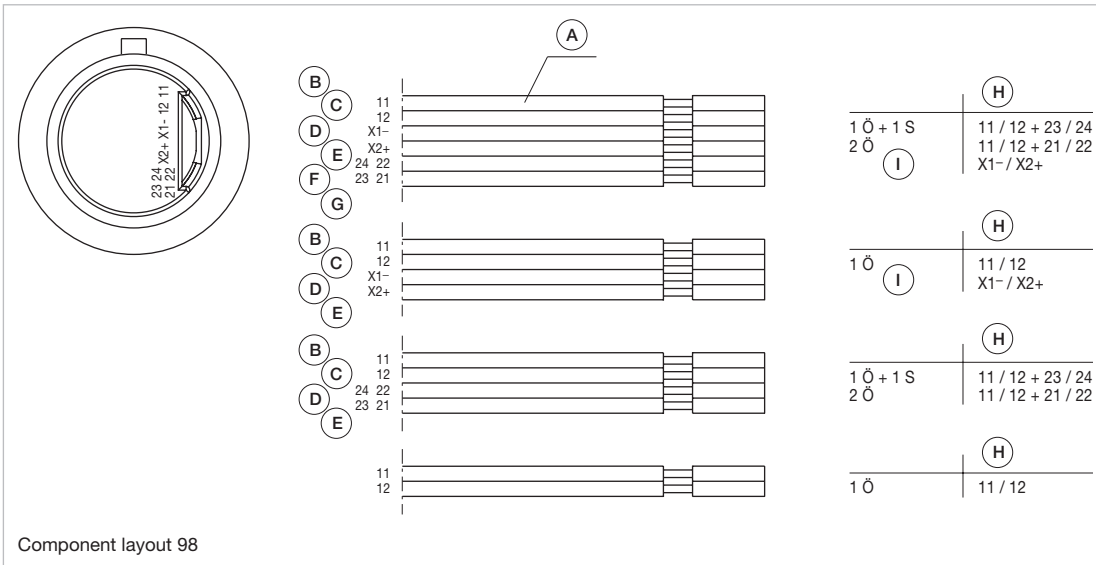

- A = Cable
- B = white
- C = brown
- D = green
- E = yellow
- F = grey
- G = pink
- H = Terminals
- I = Illumination

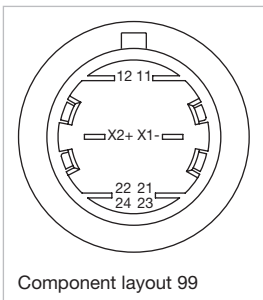

Emergency stop switch, IP65, IP66, IP67

Equipment consisting of (schematic overview)

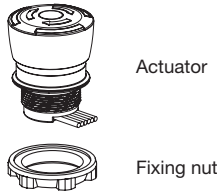

Each Part Number listed below includes all the black components shown in the 3D-drawing.

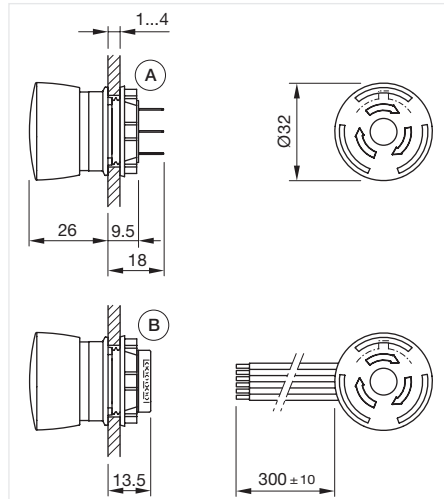

Dimensions [mm]
 A = Plug-in terminal 2.8 mm x 0.5 mm
 B = Flat ribbon cable



Product can differ from the current configuration.

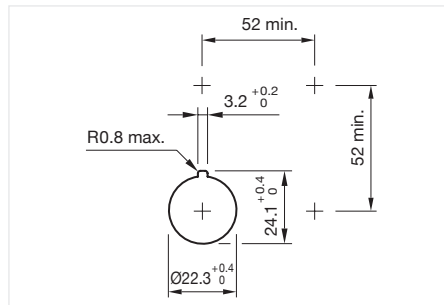

Mounting cut-outs [mm]

General information

- Lens plastic red



Emergency stop switch, Front dimension Ø 32 mm

Switching action	Contacts	Terminal	Lens colour	Illumination colour	Product attributes	Switching position ring	Part No.	Wiring diagram	Component Layout
Maintained	1 NC	Plug-in terminal, 2.8 x 0.5 mm	Red / White		Switching position ring black	Black	84-5220.0020	345	99
	1 NC	Flat ribbon cable 300 mm	Red / White		Switching position ring black	Black	84-5220.0040	426	98
	1 NC	Plug-in terminal, 2.8 x 0.5 mm	Red	Red	Switching position ring black	Black	84-5221.2B20	348	99
	1 NC	Flat ribbon cable 300 mm	Red	Red	Switching position ring black	Black	84-5221.2B40	429	98
	1 NC / 1 NO	Plug-in terminal, 2.8 x 0.5 mm	Red / White		Switching position ring black	Black	84-5230.0020	346	99
	1 NC / 1 NO	Flat ribbon cable 300 mm	Red / White		Switching position ring black	Black	84-5230.0040	427	98
	1 NC / 1 NO	Plug-in terminal, 2.8 x 0.5 mm	Red	Red	Switching position ring black	Black	84-5231.2B20	349	99
	1 NC / 1 NO	Flat ribbon cable 300 mm	Red	Red	Switching position ring black	Black	84-5231.2B40	430	98
	2 NC	Plug-in terminal, 2.8 x 0.5 mm	Red / White		Switching position ring black	Black	84-5240.0020	347	99
	2 NC	Flat ribbon cable 300 mm	Red / White		Switching position ring black	Black	84-5240.0040	428	98
	2 NC	Plug-in terminal, 2.8 x 0.5 mm	Red	Red	Switching position ring black	Black	84-5241.2B20	350	99

Contacts: NC = Normally closed, NO = Normally open

84 Raised design

Switching action	Contacts	Terminal	Lens colour	Illumination colour	Product attributes	Switching position ring	Part No.	Wiring diagram	Component Layout
Maintained	2 NC	Flat ribbon cable 300 mm	Red	Red	Switching position ring black	Black	84-5241.2B40	431	98
	1 NC	Plug-in terminal, 2.8 x 0.5 mm	Red / White		Switching position ring green	Green	84-5320.0020	345	99
	1 NC	Flat ribbon cable 300 mm	Red / White		Switching position ring green	Green	84-5320.0040	426	98
	1 NC	Plug-in terminal, 2.8 x 0.5 mm	Red	Red	Switching position ring green	Green	84-5321.2B20	347	99
	1 NC	Flat ribbon cable 300 mm	Red	Red	Switching position ring green	Green	84-5321.2B40	429	98
	1 NC / 1 NO	Plug-in terminal, 2.8 x 0.5 mm	Red / White		Switching position ring green	Green	84-5330.0020	346	99
	1 NC / 1 NO	Flat ribbon cable 300 mm	Red / White		Switching position ring green	Green	84-5330.0040	427	98
	1 NC / 1 NO	Plug-in terminal, 2.8 x 0.5 mm	Red	Red	Switching position ring green	Green	84-5331.2B20	349	99
	1 NC / 1 NO	Flat ribbon cable 300 mm	Red	Red	Switching position ring green	Green	84-5331.2B40	430	98
	2 NC	Plug-in terminal, 2.8 x 0.5 mm	Red / White		Switching position ring green	Green	84-5340.0020	347	99
	2 NC	Flat ribbon cable 300 mm	Red / White		Switching position ring green	Green	84-5340.0040	428	98
	2 NC	Plug-in terminal, 2.8 x 0.5 mm	Red	Red	Switching position ring green	Green	84-5341.2B20	350	99
	2 NC	Flat ribbon cable 300 mm	Red	Red	Switching position ring green	Green	84-5341.2B40	431	98
	1 NC	Plug-in terminal, 2.8 x 0.5 mm	Red		Switching position ring green	Green	84-5520.0020	345	99
	1 NC / 1 NO	Plug-in terminal, 2.8 x 0.5 mm	Red		Switching position ring green	Green	84-5530.0020	346	99
	2 NC	Plug-in terminal, 2.8 x 0.5 mm	Red		Switching position ring green	Green	84-5540.0020	347	99
	1 NC	Flat ribbon cable 300 mm	Red		Switching position ring green	Green	84-5520.0040	426	98
	1 NC / 1 NO	Flat ribbon cable 300 mm	Red		Switching position ring green	Green	84-5530.0040	427	98
	2 NC	Flat ribbon cable 300 mm	Red		Switching position ring green	Green	84-5540.0040	428	98

Contacts: NC = Normally closed, NO = Normally open

Wiring diagrams

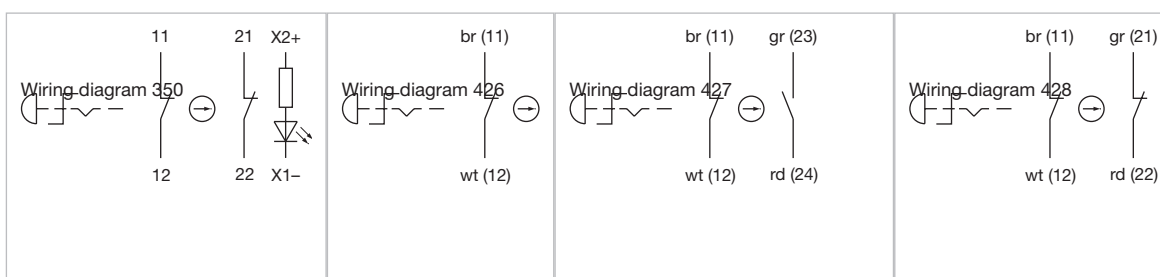
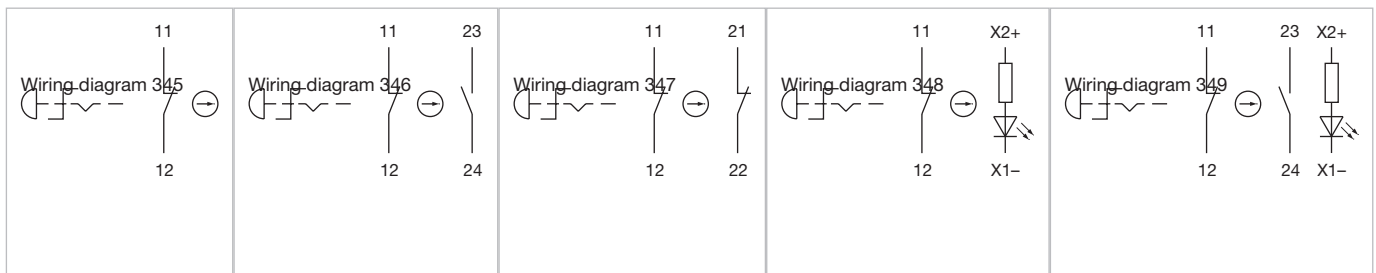

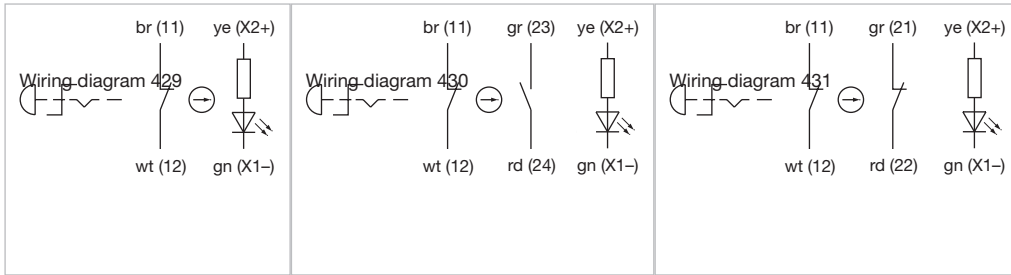

Component layouts

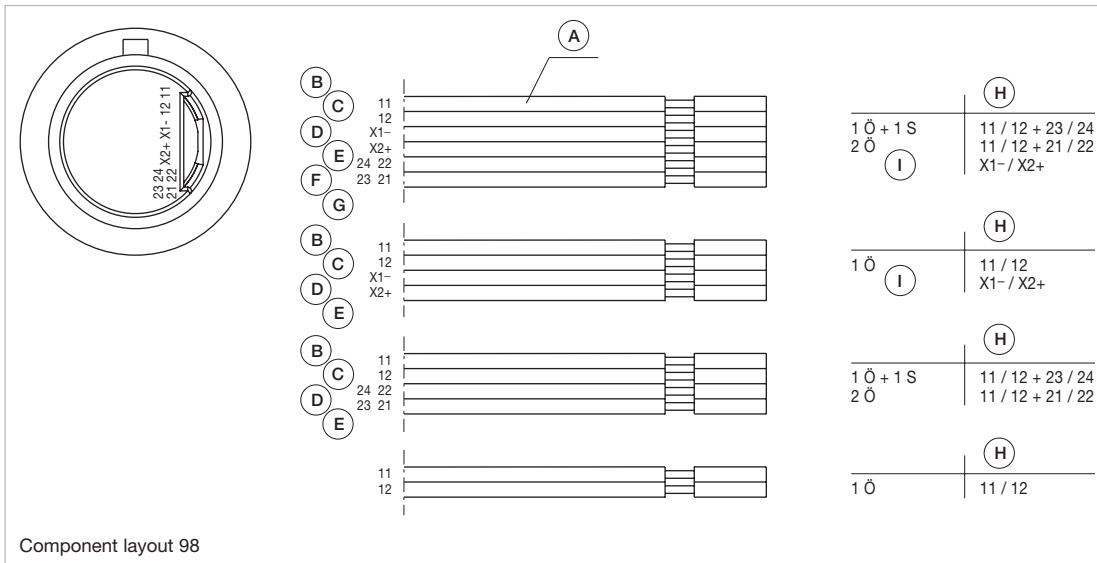

- A = Cable
- B = white
- C = brown
- D = green
- E = yellow
- F = grey
- G = pink
- H = Terminals
- I = Illumination

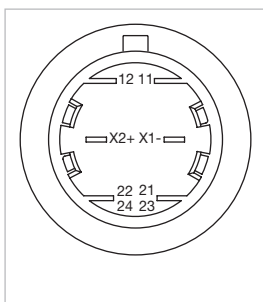

Component layout 99

84 Raised design

Emergency stop switch, Bi-Colour, IP65, IP66, IP67



Product can differ from the current configuration.

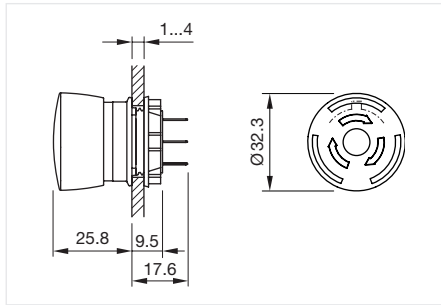

Dimensions [mm]

Equipment consisting of (schematic overview)

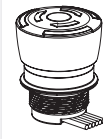

Actuator



Fixing nut

Each Part Number listed below includes all the black components shown in the 3D-drawing.

General information

- Lens plastic red
- Without built-in series resistor
- Operating voltage LED 2,2 VDC (Red), 2,6 VDC (Green)

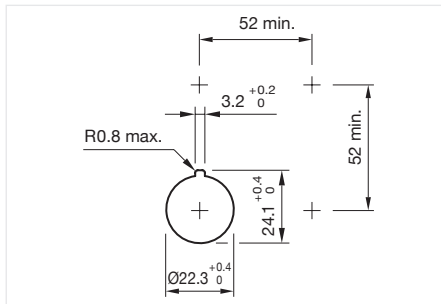

Mounting cut-outs [mm]



Emergency stop switch, Front dimension Ø 32 mm

Switching action	Contacts	Terminal	Lens colour	Illumination colour	Product attributes	Switching position ring	Part No.	Wiring diagram	Component Layout
Maintained	2 NC	Plug-in terminal, 2.8 x 0.5 mm	Red	Red / Green	Twist to unlock clockwise, position indication ring black	Black	84-5241.8D20	344	99
	2 NC	Plug-in terminal, 2.8 x 0.5 mm	Red	Red / Green	Twist to unlock clockwise, position indication ring green	Green	84-5341.8D20	344	99
	2 NC	Flat ribbon cable 300 mm	Red	Red / Green	Twist to unlock clockwise, position indication ring black	Black	84-5241.8D40	344	98
	2 NC	Flat ribbon cable 300 mm	Red	Red / Green	Twist to unlock clockwise, position indication ring green	Green	84-5341.8D40	344	98

Contacts: NC = Normally closed

Wiring diagrams

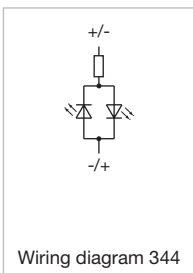

Component layouts

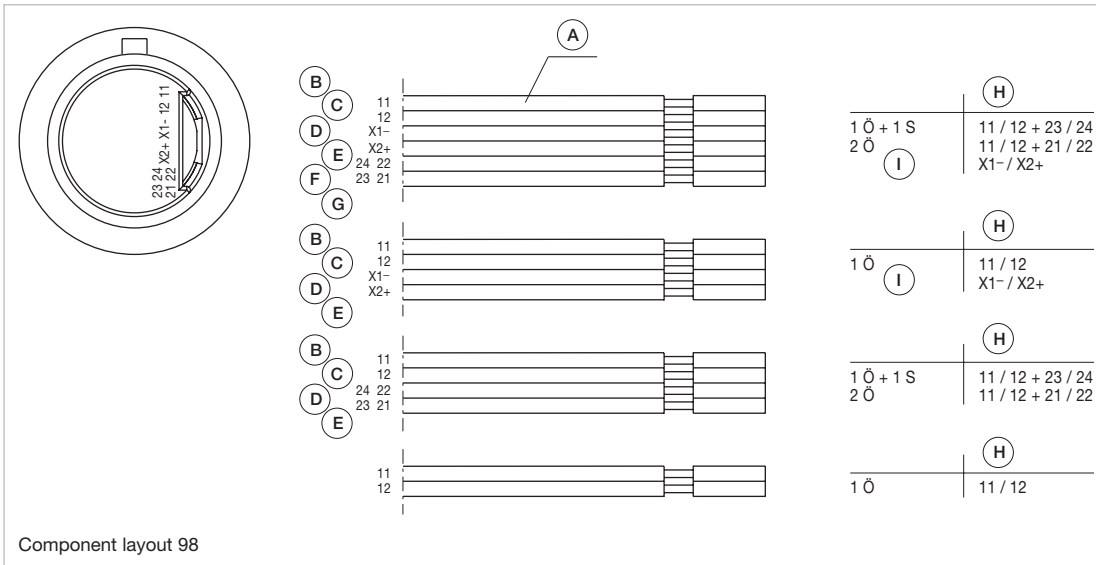

- A = Cable
- B = white
- C = brown
- D = green
- E = yellow
- F = grey
- G = pink
- H = Terminals
- I = Illumination

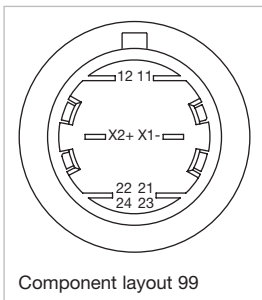

84 Raised design

USB socket



Actuator

Terminal	Terminal length cable	Mounting cut-out	Front dimension	Part No.
USB 3.0 socket type A-A	600.00 mm	Ø 30.1 mm	Ø 34,75 mm	84-3103.0000.1
	1000.00 mm	Ø 30.1 mm	Ø 34,75 mm	84-3103.0000.2



Lens for stop request pushbutton

Lens material	Lens colour	Lens optics	Lens shape	Lens illumination	Lens type	Symbol	Dimension	Part No.
Aluminium	Nature	opaque	flush	non illuminative	raised above front bezel	Door open	Ø 19.7 mm	84-7205.804A
	Nature	opaque	flush	non illuminative	raised above front bezel	Wheelchair	Ø 19.7 mm	84-7205.805A
	Nature	opaque	flush	non illuminative	raised above front bezel	Baby pram	Ø 19.7 mm	84-7205.806A
	Nature	opaque	flush	non illuminative	raised above front bezel	Bell	Ø 19.7 mm	84-7205.808A

Additional information

- With raised labelling symbol, TSI compliant
- The colour of anodised aluminium parts can vary due to technical production reasons



Lens metal for halo illumination

Lens material	Lens colour	Lens optics	Lens shape	Lens illumination	Lens type	Symbol	Dimension	Part No.
Aluminium	Black	opaque	flush	non illuminative	raised above front bezel	no symbol	Ø 19.7 mm	84-7205.000A
	Red	opaque	flush	non illuminative	raised above front bezel	no symbol	Ø 19.7 mm	84-7205.200A
	Olive green	opaque	flush	non illuminative	raised above front bezel	no symbol	Ø 19.7 mm	84-7205.500A
	Blue	opaque	flush	non illuminative	raised above front bezel	no symbol	Ø 19.7 mm	84-7205.600A
	Nature	opaque	flush	non illuminative	raised above front bezel	no symbol	Ø 19.7 mm	84-7205.800A
	Black	opaque	convex	non illuminative	raised above front bezel	no symbol	Ø 19.7 mm	84-7202.000A
	Red	opaque	convex	non illuminative	raised above front bezel	no symbol	Ø 19.7 mm	84-7202.200A
	Blue	opaque	convex	non illuminative	raised above front bezel	no symbol	Ø 19.7 mm	84-7202.600A
	Nature	opaque	convex	non illuminative	raised above front bezel	no symbol	Ø 19.7 mm	84-7202.800A

Additional information

- The colour of anodised aluminium parts can vary due to technical production reasons

84 Components



Lens plastic

Lens material	Lens colour	Lens optics	Lens shape	Lens illumination	Lens type	Symbol	Dimension	Part No.
Plastic	Red	transparent	flush	illuminative	level with front bezel	no symbol	Ø 19.7 mm	84-7111.200
	Orange	transparent	flush	illuminative	level with front bezel	no symbol	Ø 19.7 mm	84-7111.300
	Yellow	transparent	flush	illuminative	level with front bezel	no symbol	Ø 19.7 mm	84-7111.400
	Green	transparent	flush	illuminative	level with front bezel	no symbol	Ø 19.7 mm	84-7111.500
	Blue	transparent	flush	illuminative	level with front bezel	no symbol	Ø 19.7 mm	84-7111.600
	Colourless	transparent	flush	illuminative	level with front bezel	no symbol	Ø 19.7 mm	84-7111.700
	Black	opaque	flush	non illuminative	level with front bezel	no symbol	Ø 19.7 mm	84-7121.000
	Grey	opaque	flush	non illuminative	level with front bezel	no symbol	Ø 19.7 mm	84-7121.800
	Red	transparent	flush	illuminative	raised above front bezel	no symbol	Ø 19.7 mm	84-7115.200
	Orange	transparent	flush	illuminative	raised above front bezel	no symbol	Ø 19.7 mm	84-7115.300
	Yellow	transparent	flush	illuminative	raised above front bezel	no symbol	Ø 19.7 mm	84-7115.400
	Green	transparent	flush	illuminative	raised above front bezel	no symbol	Ø 19.7 mm	84-7115.500
	Blue	transparent	flush	illuminative	raised above front bezel	no symbol	Ø 19.7 mm	84-7115.600
	Colourless	transparent	flush	illuminative	raised above front bezel	no symbol	Ø 19.7 mm	84-7115.700
	Black	opaque	flush	non illuminative	raised above front bezel	no symbol	Ø 19.7 mm	84-7125.000
	Grey	opaque	flush	non illuminative	raised above front bezel	no symbol	Ø 19.7 mm	84-7125.800



Lens plastic with symbol

Lens material	Lens colour	Lens optics	Lens shape	Lens illumination	Lens type	Symbol	Dimension	Part No.
Plastic	Red	transparent	flush	illuminative	level with front bezel	Ring	Ø 19.7 mm	84-7111.201
	Orange	transparent	flush	illuminative	level with front bezel	Ring	Ø 19.7 mm	84-7111.301
	Yellow	transparent	flush	illuminative	level with front bezel	Ring	Ø 19.7 mm	84-7111.401
	Green	transparent	flush	illuminative	level with front bezel	Ring	Ø 19.7 mm	84-7111.501
	Blue	transparent	flush	illuminative	level with front bezel	Ring	Ø 19.7 mm	84-7111.601
	Colourless	transparent	flush	illuminative	level with front bezel	Ring	Ø 19.7 mm	84-7111.701
	Green	transparent	flush	illuminative	level with front bezel	ON/OFF	Ø 19.7 mm	84-7111.502
	Blue	transparent	flush	illuminative	level with front bezel	ON/OFF	Ø 19.7 mm	84-7111.602
	Colourless	transparent	flush	illuminative	level with front bezel	ON/OFF	Ø 19.7 mm	84-7111.702
	Green	transparent	flush	illuminative	level with front bezel	Standby	Ø 19.7 mm	84-7111.503
	Blue	transparent	flush	illuminative	level with front bezel	Standby	Ø 19.7 mm	84-7111.603
	Colourless	transparent	flush	illuminative	level with front bezel	Standby	Ø 19.7 mm	84-7111.703

Additional information

- The silvery coat is being applied on the lens (screen print) with an additional protective lacquer. Further information see Technical data



Lens metal

Lens material	Lens colour	Lens optics	Lens shape	Lens illumination	Lens type	Symbol	Dimension	Part No.
Aluminium	Black	opaque	flush	non illuminative	level with front bezel	no symbol	Ø 19.7 mm	84-7201.000
	Red	opaque	flush	non illuminative	level with front bezel	no symbol	Ø 19.7 mm	84-7201.200
	Gold	opaque	flush	non illuminative	level with front bezel	no symbol	Ø 19.7 mm	84-7201.400
	Olive green	opaque	flush	non illuminative	level with front bezel	no symbol	Ø 19.7 mm	84-7201.500
	Blue	opaque	flush	non illuminative	level with front bezel	no symbol	Ø 19.7 mm	84-7201.600
	Nature	opaque	flush	non illuminative	level with front bezel	no symbol	Ø 19.7 mm	84-7201.800
	Red	opaque	flush	non illuminative	raised above front bezel	no symbol	Ø 19.7 mm	84-7205.200
	Nature	opaque	flush	non illuminative	raised above front bezel	no symbol	Ø 19.7 mm	84-7205.800
	Black	opaque	convex	non illuminative	level with front bezel	no symbol	Ø 19.7 mm	84-7202.000
	Red	opaque	convex	non illuminative	level with front bezel	no symbol	Ø 19.7 mm	84-7202.200
	Olive green	opaque	convex	non illuminative	level with front bezel	no symbol	Ø 19.7 mm	84-7202.500
	Nature	opaque	convex	non illuminative	level with front bezel	no symbol	Ø 19.7 mm	84-7202.800

Additional information

- The colour of anodised aluminium parts can vary due to technical production reasons

84 Components



Lens metal with spot

Lens material	Lens colour	Lens optics	Lens shape	Lens illumination	Lens type	Symbol	Dimension	Part No.
Aluminium	Black	opaque	flush	illuminative	level with front bezel	no symbol	Ø 19.7 mm	84-7211.000
	Red	opaque	flush	illuminative	level with front bezel	no symbol	Ø 19.7 mm	84-7211.200
	Gold	opaque	flush	illuminative	level with front bezel	no symbol	Ø 19.7 mm	84-7211.400
	Olive green	opaque	flush	illuminative	level with front bezel	no symbol	Ø 19.7 mm	84-7211.500
	Blue	opaque	flush	illuminative	level with front bezel	no symbol	Ø 19.7 mm	84-7211.600
	Nature	opaque	flush	illuminative	level with front bezel	no symbol	Ø 19.7 mm	84-7211.800
	Black	opaque	flush	illuminative	raised above front bezel	no symbol	Ø 19.7 mm	84-7215.000
	Red	opaque	flush	illuminative	raised above front bezel	no symbol	Ø 19.7 mm	84-7215.200
	Gold	opaque	flush	illuminative	raised above front bezel	no symbol	Ø 19.7 mm	84-7215.400
	Olive green	opaque	flush	illuminative	raised above front bezel	no symbol	Ø 19.7 mm	84-7215.500
	Blue	opaque	flush	illuminative	raised above front bezel	no symbol	Ø 19.7 mm	84-7215.600
	Nature	opaque	flush	illuminative	raised above front bezel	no symbol	Ø 19.7 mm	84-7215.800

Additional information

- The colour of anodised aluminium parts can vary due to technical production reasons



Mushroom-head cap

Lens material	Lens colour	Lens optics	Lens shape	Lens illumination	Symbol	Dimension	Part No.
Plastic	Blue	transparent	mushroom-head	illuminative	no symbol		84-7114.600A
	Black	opaque	mushroom-head	non illuminative	no symbol	Ø 25 mm	84-7124.000A
	Red	opaque	mushroom-head	non illuminative	no symbol	Ø 25 mm	84-7124.200A



Marking plate

Marking plate material	Marking plate colour	Marking plate optics	Marking plate illumination	Dimension	Diameter	Part No.
Plastic	Colourless	transparent	illuminative	Ø 16 mm	16 mm	61-9707.7

Additional information

- Can be hot stamped



Single-LED, T1 3/4 MG

Illumination colour	Operating voltage	Lumi. Intensity	Dom. Wavelength	Forward voltage	Part No.	Wiring diagram
Red	2 - 6,00 V DC	160 mcd	625 nm	2.0 VDC @ 20 mA	10-2601.3172S	4
Amber	2 - 6,00 V DC	165 mcd	605 nm	2.0 VDC @ 20 mA	10-2601.3173S	4
Yellow	2 - 6,00 V DC	600 mcd	580 nm	2.9 VDC @ 20 mA	10-2603.3174S	4
Green	2 - 6,00 V DC	650 mcd	525 nm	3.2 VDC @ 20 mA	10-2603.3175S	4
Blue	2 - 6,00 V DC	250 mcd	467 nm	3.0 VDC @ 20 mA	10-2603.3176S	4
White	2 - 6,00 V DC	500 mcd	x: 0,31 / y: 0,32 nm	3.2 VDC @ 20 mA	10-2603.3178S	4

Additional information

- The customer has to decide what series resistor shall be used to the LED
- Luminosity and wave length variations caused by LED manufacturing processes may cause slight differences regarding the illumination. The customer has to decide what resistor shall be used to the LED

Wiring diagrams

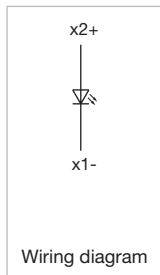

Bi-colour LED, T1 Bi-Pin

Illumination colour	Lumi. Intensity	Dom. Wavelength	Forward voltage	Part No.	Wiring diagram
Red / Green	1000/1800 mcd	628/525 nm	1.9 / 3.5 VDC @ 20 mA	10-2603.320AL	352
Green / Yellow	1100/900 mcd	588/525 nm	2.0/3.2 VDC @ 20 mA	10-2603.320CL	352

Additional information

- The customer has to decide what series resistor shall be used to the LED
- Luminosity and wave length variations caused by LED manufacturing processes may cause slight differences regarding the illumination. The customer has to decide what resistor shall be used to the LED

Wiring diagrams

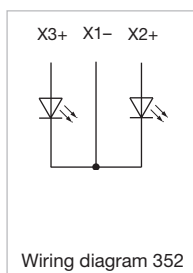

84 Components



Switching element with illumination and plug-in terminal

Switching voltage	Switching current	Contacts	Contact material	Terminal	Part No.	Wiring diagram
42.00 V	.10 A	1 NO	Gold-plated silver	Plug-in terminal, 2.8 x 0.8 mm	84-8511.2320	354
	.10 A	1 NO	Gold-plated silver	Plug-in terminal, 2.8 x 0.8 mm	84-8511.3320	354
	.10 A	1 NO	Gold-plated silver	Plug-in terminal, 2.8 x 0.8 mm	84-8511.4320	354
	.10 A	1 NO	Gold-plated silver	Plug-in terminal, 2.8 x 0.8 mm	84-8511.5320	354
	.10 A	1 NO	Gold-plated silver	Plug-in terminal, 2.8 x 0.8 mm	84-8511.6320	354
	.10 A	1 NO	Gold-plated silver	Plug-in terminal, 2.8 x 0.8 mm	84-8511.9320	354
	.10 A	1 NO	Gold-plated silver	Plug-in terminal, 2.8 x 0.8 mm	84-8511.2620	354
	.10 A	1 NO	Gold-plated silver	Plug-in terminal, 2.8 x 0.8 mm	84-8511.3620	354
	.10 A	1 NO	Gold-plated silver	Plug-in terminal, 2.8 x 0.8 mm	84-8511.4620	354
	.10 A	1 NO	Gold-plated silver	Plug-in terminal, 2.8 x 0.8 mm	84-8511.5620	354
	.10 A	1 NO	Gold-plated silver	Plug-in terminal, 2.8 x 0.8 mm	84-8511.6620	354
	.10 A	1 NO	Gold-plated silver	Plug-in terminal, 2.8 x 0.8 mm	84-8511.9620	354

Contacts: NO = Normally open

Additional information

- LED and built-in resistor included
- Standard version: Cable length 300 mm
- Other options on request: Customisation of cable and connectors, rear side fully sealed (IP 67)
- Protection degree (rear side): IP 40, upgrade to IP 67 with plug Part No. 84-900 possible. With applications where strong vibrations occur, the plugs may become loose
- Luminosity and wave length variations caused by LED manufacturing processes may cause slight differences regarding the illumination. The customer has to decide what resistor shall be used to the LED

Wiring diagrams

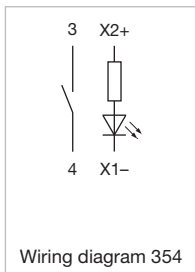



Switching element with illumination and flat ribbon cable

Operating voltage	Operation current	Switching system	Contacts	Contact material	Illumination colour	Terminal	Part No.	Wiring diagram	Component Layout
12 V DC $\pm 10\%$	10 mA	Short-travel element	1 NO	Gold-plated silver	Red	Flat ribbon cable	84-8511.2340	354	119
	10 mA	Short-travel element	1 NO	Gold-plated silver	Yellow	Flat ribbon cable	84-8511.4340	354	119
	10 mA	Short-travel element	1 NO	Gold-plated silver	Green	Flat ribbon cable	84-8511.5340	354	119
	10 mA	Short-travel element	1 NO	Gold-plated silver	Blue	Flat ribbon cable	84-8511.6340	354	119
	10 mA	Short-travel element	1 NO	Gold-plated silver	White	Flat ribbon cable	84-8511.9340	354	119
24 V DC $\pm 10\%$	10 mA	Short-travel element	1 NO	Gold-plated silver	Red	Flat ribbon cable	84-8511.2640	354	119
	10 mA	Short-travel element	1 NO	Gold-plated silver	Orange	Flat ribbon cable	84-8511.3640	354	119
	10 mA	Short-travel element	1 NO	Gold-plated silver	Yellow	Flat ribbon cable	84-8511.4640	354	119
	10 mA	Short-travel element	1 NO	Gold-plated silver	Green	Flat ribbon cable	84-8511.5640	354	119
	10 mA	Short-travel element	1 NO	Gold-plated silver	Blue	Flat ribbon cable	84-8511.6640	354	119
	10 mA	Short-travel element	1 NO	Gold-plated silver	White	Flat ribbon cable	84-8511.9640	354	119

Contacts: NO = Normally open

Additional information

- LED and built-in resistor included
- Standard version: Cable length 300 mm
- Other options on request: Customisation of cable and connectors, rear side fully sealed (IP 67)
- Protection degree (rear side): IP 40, upgrade to IP 67 with plug Part No. 84-900 possible. With applications where strong vibrations occur, the plugs may become loose
- Luminosity and wave length variations caused by LED manufacturing processes may cause slight differences regarding the illumination. The customer has to decide what resistor shall be used to the LED

Wiring diagrams

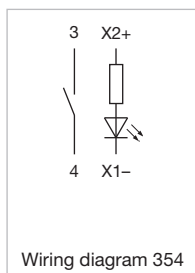

84 Components



Switching element Bi-colour

Operating voltage	Operation current	Switching system	Contacts	Contact material	Illumination colour	Terminal	Part No.	Wiring diagram	Component Layout
24 V DC $\pm 10\%$	10 mA	Short-travel element	1 NO	Gold-plated silver	Red / Green	Flat ribbon cable	84-8515.8640	355	120
	10 mA	Short-travel element	1 NO	Gold-plated silver	Yellow / Green	Flat ribbon cable	84-8515.7640	355	120

Contacts: NO = Normally open

Additional information

- LED and built-in resistor included
- Cable connection IP 67, rear side fully sealed. The illumination element of the cable version cannot be disconnected from the actuator any longer
- Best illumination level will be reached with aluminium lens with spot, Part No. 84-7215.x00 and 84-7211.x00
- Standard version: Cable length 300 mm
- Other options on request: Customisation of cable and connectors, rear side fully sealed (IP 67)
- Luminosity and wave length variations caused by LED manufacturing processes may cause slight differences regarding the illumination. The customer has to decide what resistor shall be used to the LED

Wiring diagrams

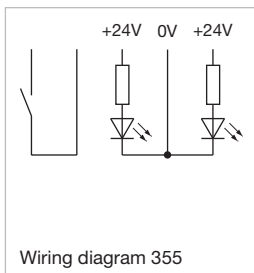

Switching element without illumination

Switching voltage	Switching current	Contacts	Contact material	Terminal	Part No.	Wiring diagram	Component Layout
42.00 V	.10 A	1 NO	Gold-plated silver	Plug-in terminal, 2.8 x 0.8 mm	84-8510.0020	356	
Short-travel element	1 NO	Gold-plated silver	Flat ribbon cable		84-8510.0040	356	117

Contacts: NO = Normally open

Additional information

- Standard version: Cable length 300 mm
- Other options on request: Customisation of cable and connectors, rear side fully sealed (IP 67)
- Protection degree (rear side): IP 40, upgrade to IP 67 with plug Part No. 84-900 possible. With applications where strong vibrations occur, the plugs may become loose

Wiring diagrams

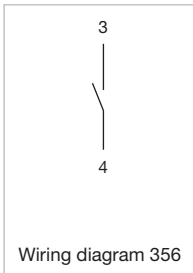

Switching element PCB illuminative

Switching system	Contacts	Contact material	Terminal	Part No.	Wiring diagram	Component Layout
Short-travel element	1 NO	Gold	PCB terminal	92-851.342	332	82

Contacts: NO = Normally open

Additional information

- The customer has to decide what series resistor shall be used to the LED
- LED and mounting flange to be ordered separately

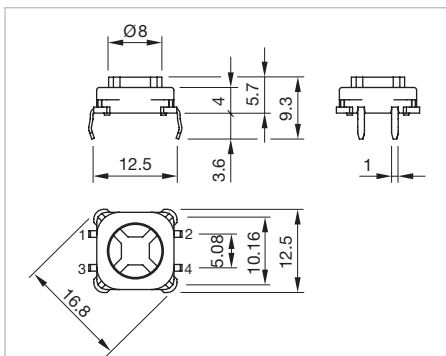

Dimensions [mm]

Wiring diagrams

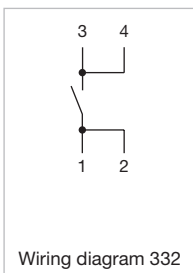

84 Components

Component layouts

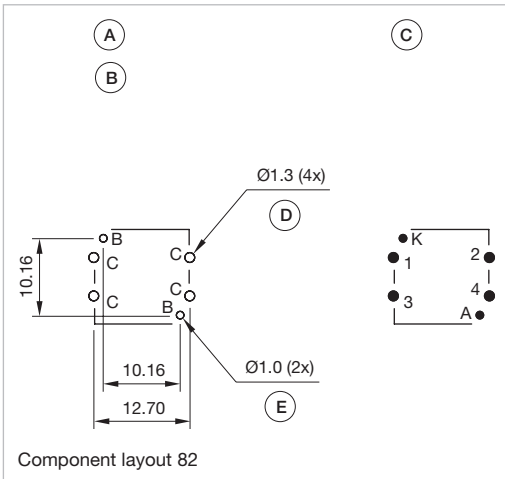

- A = Switching element with illumination
- B = Single LED
- C = Drilling plan (component side)
- D = Hole for switching element, pad max. \varnothing 2.5 mm
- E = Hole for LED



Illumination element with plug-in terminal

IP Protection	Illumination colour	Operating voltage	Terminal	Part No.	Wiring diagram
IP40	Red	12 V DC \pm 10 %	Plug-in terminal, 2.8 x 0.8 mm	84-8001.2320	351
	Yellow	12 V DC \pm 10 %	Plug-in terminal, 2.8 x 0.8 mm	84-8001.4320	351
	Green	12 V DC \pm 10 %	Plug-in terminal, 2.8 x 0.8 mm	84-8001.5320	351
	Blue	12 V DC \pm 10 %	Plug-in terminal, 2.8 x 0.8 mm	84-8001.6320	351
	White	12 V DC \pm 10 %	Plug-in terminal, 2.8 x 0.8 mm	84-8001.9320	351
	Red	24 V DC \pm 10 %	Plug-in terminal, 2.8 x 0.8 mm	84-8001.2620	351
	Amber	24 V DC \pm 10 %	Plug-in terminal, 2.8 x 0.8 mm	84-8001.3620	351
	Yellow	24 V DC \pm 10 %	Plug-in terminal, 2.8 x 0.8 mm	84-8001.4620	351
	Green	24 V DC \pm 10 %	Plug-in terminal, 2.8 x 0.8 mm	84-8001.5620	351
	Blue	24 V DC \pm 10 %	Plug-in terminal, 2.8 x 0.8 mm	84-8001.6620	351
	White	24 V DC \pm 10 %	Plug-in terminal, 2.8 x 0.8 mm	84-8001.9620	351

Additional information

- LED and built-in resistor included
- Standard version: Cable length 300 mm
- Other options on request: Customisation of cable and connectors, rear side fully sealed (IP 67)
- Protection degree (rear side): IP 40, upgrade to IP 67 with plug Part No. 84-900 possible. With applications where strong vibrations occur, the plugs may become loose
- Luminosity and wave length variations caused by LED manufacturing processes may cause slight differences regarding the illumination. The customer has to decide what resistor shall be used to the LED
- Standard version: Cable length 300 mm with insulated ferrule, plug-in terminal 2.8 mm x 0.5 mm

Wiring diagrams

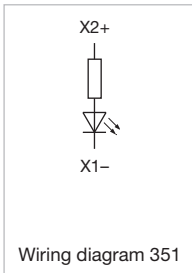

Illumination element with flat ribbon cable

IP Protection	Illumination colour	Operating voltage	Terminal	Part No.	Wiring diagram	Component Layout
IP40	Red	12 V DC ± 10 %	Flat ribbon cable	84-8001.2340	351	118
	Yellow	12 V DC ± 10 %	Flat ribbon cable	84-8001.4340	351	
	Green	12 V DC ± 10 %	Flat ribbon cable	84-8001.5340	351	118
	White	12 V DC ± 10 %	Flat ribbon cable	84-8001.9340	351	118
	Red	24 V DC ± 10 %	Flat ribbon cable	84-8001.2640	351	118
	Amber	24 V DC ± 10 %	Flat ribbon cable	84-8001.3640	351	118
	Yellow	24 V DC ± 10 %	Flat ribbon cable	84-8001.4640	351	118
	Green	24 V DC ± 10 %	Flat ribbon cable	84-8001.5640	351	118
	Blue	24 V DC ± 10 %	Flat ribbon cable	84-8001.6640	351	118
	White	24 V DC ± 10 %	Flat ribbon cable	84-8001.9640	351	118

Additional information

- LED and built-in resistor included
- Standard version: Cable length 300 mm
- Other options on request: Customisation of cable and connectors, rear side fully sealed (IP 67)
- Protection degree (rear side): IP 40, upgrade to IP 67 with plug Part No. 84-900 possible. With applications where strong vibrations occur, the plugs may become loose
- Luminosity and wave length variations caused by LED manufacturing processes may cause slight differences regarding the illumination. The customer has to decide what resistor shall be used to the LED

Wiring diagrams

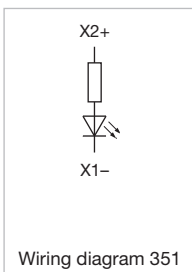

84 Components



Illumination element bi-colour

IP Protection	Illumination colour	Operating voltage	Terminal	Part No.	Wiring diagram	Component Layout
IP40	Red / Green	24 V AC/DC ± 10 %	Plug-in terminal, 2.8 x 0.8 mm	84-8005.8620	353	
IP67	Red / Green	24 V AC/DC ± 10 %	Flat ribbon cable	84-8005.8640	353	121

Additional information

- LED and built-in resistor included
- Standard version: Cable length 300 mm
- Other options on request: Customisation of cable and connectors, rear side fully sealed (IP 67)
- Best illumination level will be reached with aluminium lens with spot, Part No. 84-7215.x00 and 84-7211.x00
- Protection degree (rear side): IP 40, upgrade to IP 67 with plug Part No. 84-900 possible. With applications where strong vibrations occur, the plugs may become loose
- Cable connection IP 67, rear side fully sealed. The illumination element of the cable version cannot be disconnected from the actuator any longer
- Luminosity and wave length variations caused by LED manufacturing processes may cause slight differences regarding the illumination. The customer has to decide what resistor shall be used to the LED

Wiring diagrams

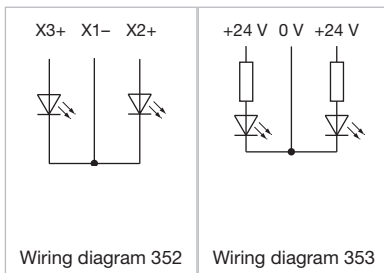



Switching element Halo Compact

Contacts	Contact material	Terminal	Part No.	Wiring diagram	Component Layout
1 NO	Gold-plated silver	Plug-in terminal, 2.8 x 0.8 mm	84-8716.2620	439	103
	Gold-plated silver	Plug-in terminal, 2.8 x 0.8 mm	84-8716.4620	439	103
	Gold-plated silver	Plug-in terminal, 2.8 x 0.8 mm	84-8716.5620	439	103
	Gold-plated silver	Plug-in terminal, 2.8 x 0.8 mm	84-8716.6620	439	103
	Gold-plated silver	Plug-in terminal, 2.8 x 0.8 mm	84-8716.9620	439	103
	Gold-plated silver	Plug-in terminal, 2.8 x 0.8 mm	84-8716.8620	439	103

Contacts: NO = Normally open

Additional information

- Preconfigured light sequences see Technical data
- Integrated electronic switch for latching function (High-Side-Switch)

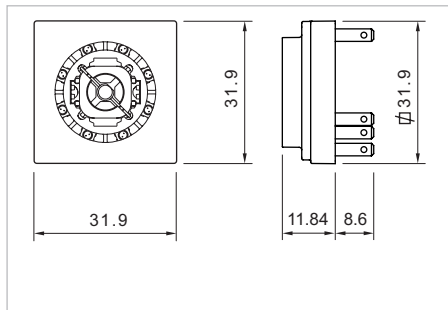

Dimensions [mm]

Wiring diagrams

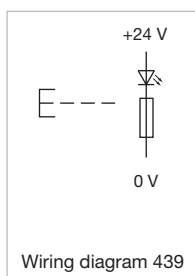

84 Components

Component layouts

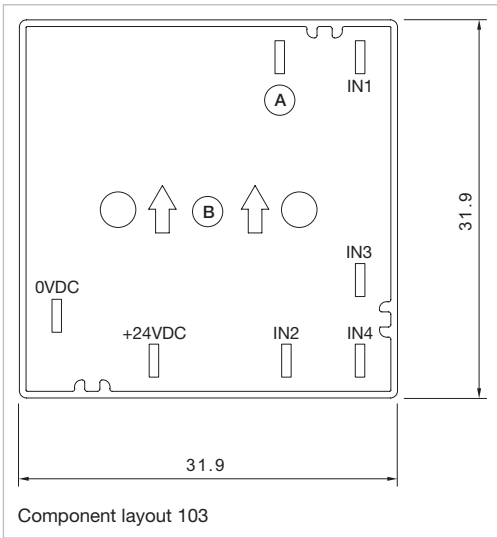

A = Switch out
B = Top



Illumination element PCB

Terminal	Part No.	Wiring diagram	Component Layout
PCB terminal	92-800.042	330	79

Additional information

- The customer has to decide what series resistor shall be used to the LED
- LED and mounting flange to be ordered separately

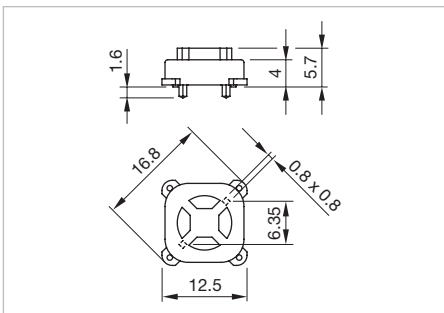

Dimensions [mm]

Wiring diagrams

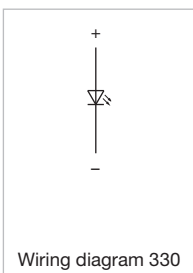

Component layouts

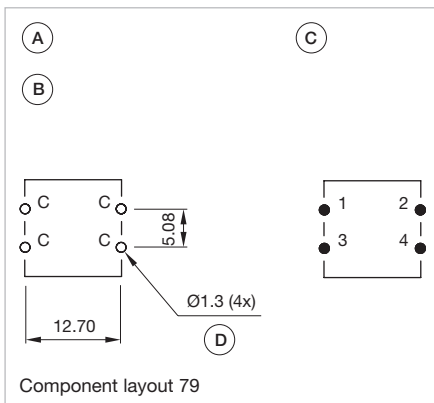

- A = Switching element without illumination
- B = Drilling plan (component side)
- C = Occupancy plan (component side)
- D = Hole for switching element



Mounting flange

Product attributes	Material	Fastening	Part No.
Tightening torque fixing screw 0.3 Nm	Plastic	With screws	92-960.0
	Plastic	Mit Schrauben	84-960.0

Additional information

- For discrete switching applications including switching element and mounting flange, soldering terminal (assembled PCB incl. series resistor and LED on request)
- Halo illumination (illuminated multi-color bezel)

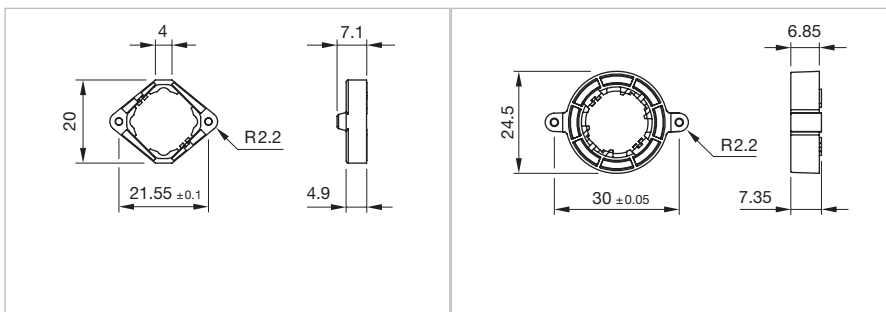

Dimensions [mm]
for Part No. 92-960.0

Dimensions [mm]
for Part No. 84-960.0

84 Accessories

Front side



Legend frame

Dimension	Material	Colour	Surface	Mounting type	Mounting cut-out	Part No.
30 mm x 50 mm	Aluminium	Black	anodised	adhesive	Ø 22.5 mm	61-9980.0

Additional information

- For devices with front dimension Ø 25 mm, flush design
- The colour of anodised aluminium parts can vary due to technical production reasons

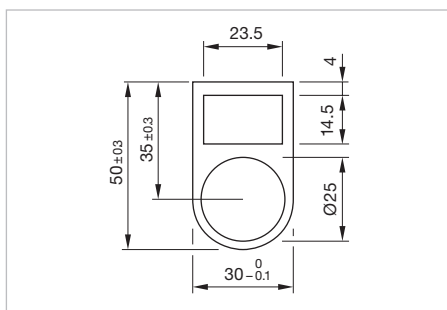

Dimensions [mm]



Legend plate

Product attributes	Dimension	Material	Colour	Surface	Mounting type	Part No.
For legend frame Part No.704.968.2 and 704.968.3	14.5 mm x 23.5 mm	Aluminium	Nature	anodised	adhesive	704.968.0
	14.5 mm x 23.5 mm	Aluminium	Black	anodised	adhesive	704.968.1

Additional information

- The colour of anodised aluminium parts can vary due to technical production reasons



Emergency stop legend

Dimension	Material	Colour	Mounting cut-out	Marking	Part No.
Ø 60 mm	Plastic	Yellow	Ø 22.5 mm	NOT AUS	704.963.5
	Plastic	Yellow	Ø 22.5 mm	EMERGENCY STOP	704.963.6
	Plastic	Yellow	Ø 22.5 mm	ARRET D'URGENCE	704.963.7
	Plastic	Yellow	Ø 22.5 mm	NOT HALT	704.963.8
	Plastic	Yellow	Ø 22.5 mm	EN ISO 13850 symbol	704.963.9
Ø 90 mm	Plastic	Yellow	Ø 22.5 mm	NOT AUS	704.963.0
	Plastic	Yellow	Ø 22.5 mm	EMERGENCY STOP	704.963.1
	Plastic	Yellow	Ø 22.5 mm	ARRET D'URGENCE	704.963.2
	Plastic	Yellow	Ø 22.5 mm	NOT HALT	704.963.3
	Plastic	Yellow	Ø 22.5 mm	EN ISO 13850 symbol	704.963.4

Additional information

- Front panel thickness 3 mm max.



Blind plug

Dimension	Material	Colour	Mounting cut-out	Part No.
Ø 25 mm	Plastic	Black	Ø 22.5 mm	61-9453.0
Ø 36 mm	Plastic	Black	Ø 30.5 mm	704.964.8

Additional information

- Please note that bigger minimum distances are necessary
- Only for mounting in round hole without D-shape (Part No. 61-9453.0)

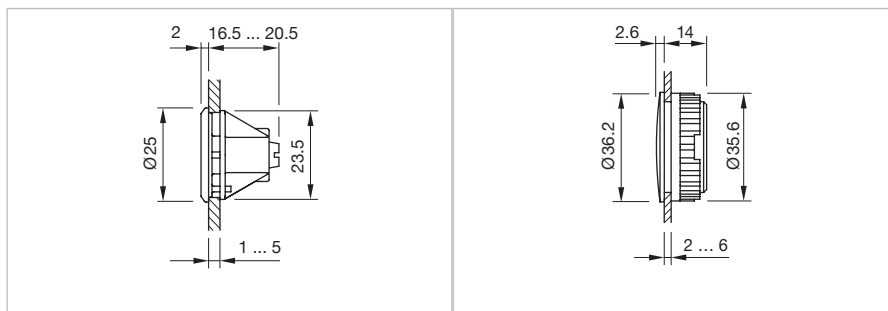

Dimensions [mm]
for Part No. 61-9453.0

Dimensions [mm]
for Part No. 704.964.8



Protective cap

Product attributes	Dimension	Material	Colour	Optics	Part No.
For front bezel Ø 25 mm	Ø 25 mm	Silicone	Colourless	transparent	84-9103.7

Additional information

- For flat lens profil only
- When using the front protection cover the external sealing in the actuator has to be removed

84 Accessories



Protection cover

Product attributes	Dimension	Material	Colour	Part No.
For USB socket	Ø 36 mm	Plastic	Black	84-916
For single pushbutton	42 mm x 33 mm x 8.5 mm	Aluminium Plastic	Colourless	84-922

Additional information

- When mounting the protective cover 84-916 make sure that the USB adapter is mounted in center position.

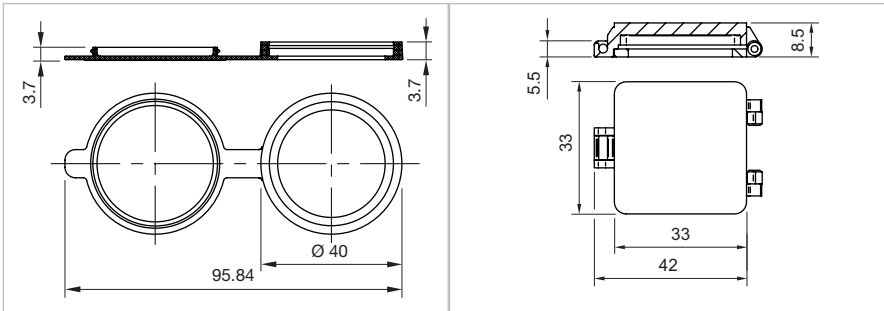

Dimensions [mm]
for Part No. 84-916

Dimensions [mm]
for Part No. 84-922



E stop protective shroud

Dimension	Material	Colour	Marking	Part No.
Ø 50 mm	Plastic	Yellow		84-902
	Plastic	Yellow	NOT - AUS	84-902A
	Plastic	Yellow	EMERGENCY STOP	84-902B
	Plastic	Yellow	NOT - HALT	84-902D
Ø 45 mm	Metal	Yellow		84-909
Ø 50 mm	Plastic	Yellow		84-906

Additional information

- Front panel thickness 1 ... 3 mm
- With anti-twist device
- When using a protective shroud the e-stop or stop-switch has to be turned by 180° to be mounted. See dimensional drawing
- The protection shroud Part No. 84-909 is not suitable for a proper use of emergency-stop. It can obstruct a spontaneous operation of the emergency-stop switch
- This shroud Part No. 84-906 is not compliant to EN ISO 13850. There are no restrictions when combined with stop switches.

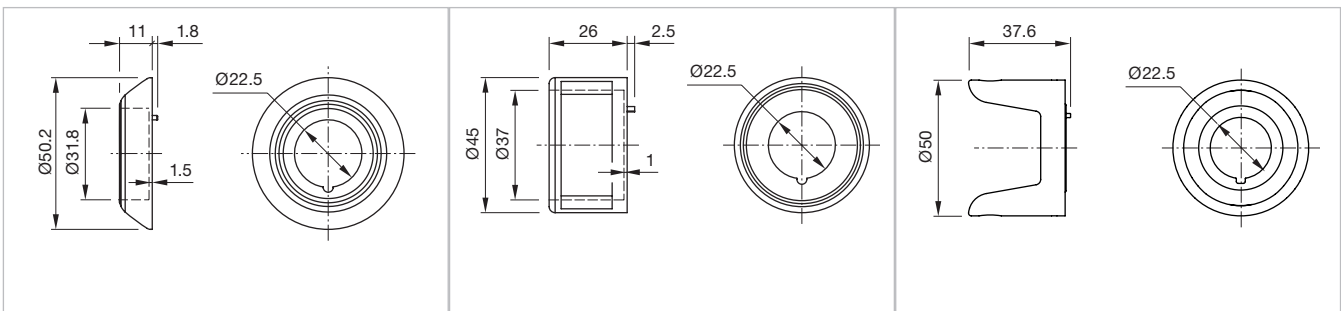

Dimensions [mm]
for Part No. 84-902, 84-902A
84-902B, 84-902C

Dimensions [mm]
for Part No. 84-909

Dimensions [mm]
for Part No. 84-906

Rear side



Adaptor reducing to 25 mm

Product attributes	Material	Colour	Part No.
For housing, pole mounting 35 mm dia.	Plastic	Yellow	84-9300.4
	Plastic	Grey	84-9300.8

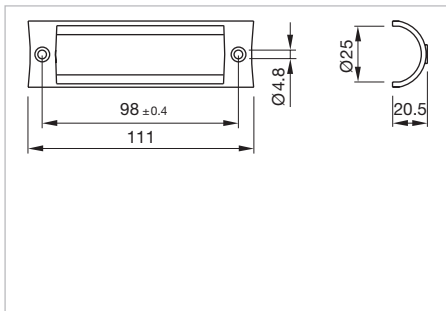

Dimensions [mm]



Adaptor reducing to 30 mm

Product attributes	Material	Colour	Part No.
For housing, pole mounting 35 mm dia.	Plastic	Yellow	84-9700.4
	Plastic	Grey	84-9700.8

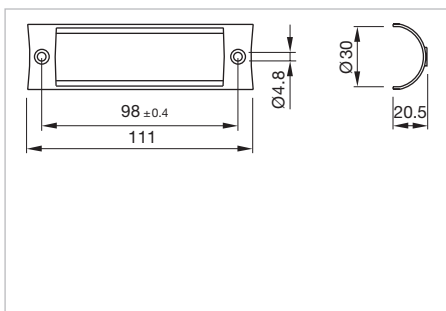

Dimensions [mm]



Flat receptacle

Product attributes	Material	Terminal	Part No.
2.8 x 0.8 mm plug-in terminal	Metal	null	84-9420



Insulation sleeve

Product attributes	Material	Terminal	Part No.
For flat receptacle 2.8 mm	Plastic	null	31-929

84 Accessories



PCB plug-in base

Product attributes	Dimension	Material	Terminal	Pins	Part No.	Component Layout
For Emergency stop switch, stop switch	20.3 mm x 15.8 mm x 8.3 mm	Metal / plastic	PCB terminal	Axial	84-920	102

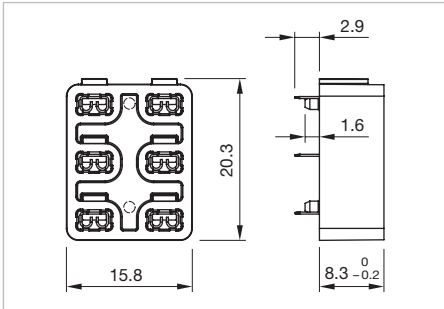

Dimensions [mm]

Component layouts

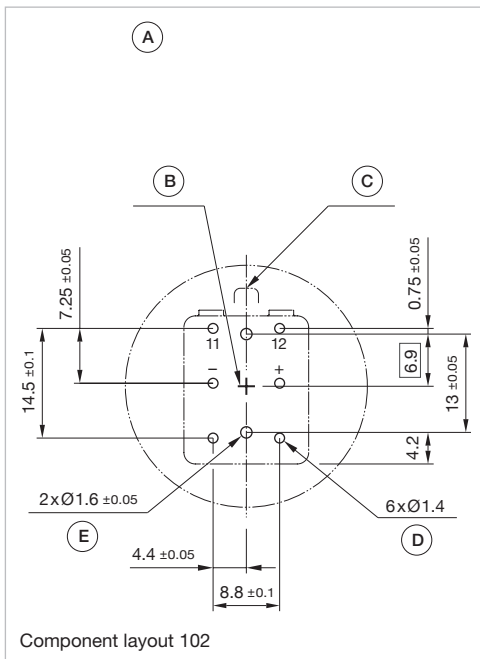

Component layout 102

- A = Drilling plan (component side)
- B = Centre from switch
- C = Anti-twist protection
- D = Pins for contacts/LED
- E = Positioning hole



Plug

Material	Terminal	Part No.
Plastic	null	84-900

Additional information

- For back protection IP67 of switching elements and illumination elements. Two plugs are necessary per element

Mounting



Enclosure

Product attributes	Dimension	Material	Colour	IP Protection	Part No.
With mounting cut-out 1 x Ø 22.3 mm, with anti-twist device	94 mm x 94 mm x 81 mm	Plastic	Grey	IP66	704.945.1
With mounting cut-out 2 x Ø 22.3 mm, with anti-twist device	130 mm x 94 mm x 81 mm	Plastic	Grey	IP66	704.945.2
With mounting cut-out 3 x Ø 22.3 mm, with anti-twist device	180 mm x 94 mm x 81 mm	Plastic	Grey	IP66	704.945.3
With mounting cut-out 4 x Ø 22.3 mm, with anti-twist device	180 mm x 182 mm x 110 mm	Plastic	Grey	IP66	704.945.4
With mounting cut-out 6 x Ø 22.3 mm, with anti-twist device	180 mm x 182 mm x 110 mm	Plastic	Grey	IP66	704.945.5
Bottom grey similar RAL 7035; cover lead-sealable, yellow similar RAL 1004	65 mm x 65 mm x 57 mm	Plastic		IP66	84-910

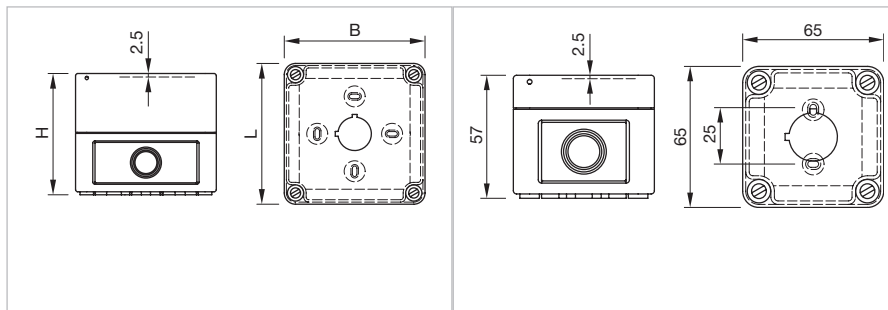

Dimensions [mm]
for Part No. 704.945.1, 704.945.2, 704.945.3,
704.945.4, 704.945.5

Dimensions [mm]
for Part No. 84-910



Fixing nut

Product attributes	Dimension	Material	Colour	Part No.
Standard version	Ø 30 mm	Plastic	Black	84-901
For emergency stop switch	Ø 28 mm	Plastic	Black	84-905
	Ø 30 mm	Plastic	Black	84-908
	Ø 25 mm	Metal	Silver	84-911



Dismantling tool

Product attributes	Material	Part No.
For dismantling switching elements or lenses	Metal / plastic	84-918

84 Accessories



Housing pole mounting 35 mm

Product attributes	Material	Colour	Mounting cut-out	Part No.
Please note: The cut-out of the pole must read min. 22 mm and needs to be aligned with the switch	Plastic	Yellow	Ø 22.5 mm	84-9500.4
	Plastic	Traffic blue		84-9500.6A
	Plastic	Grey	Ø 22.5 mm	84-9500.8

Additional information

- Screws are not contained in the scope of supply

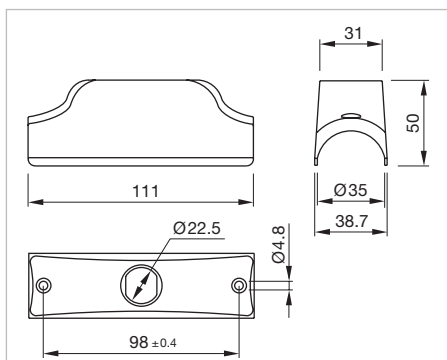

Dimensions [mm]



Housing pole mounting 38 mm

Product attributes	Material	Colour	Mounting cut-out	Part No.
Please note: The cut-out of the pole must read min. 22 mm and needs to be aligned with the switch	Plastic	Yellow	Ø 22.5 mm	84-9600.4
	Plastic	Grey	Ø 22.5 mm	84-9600.8

Additional information

- Screws are not contained in the scope of supply

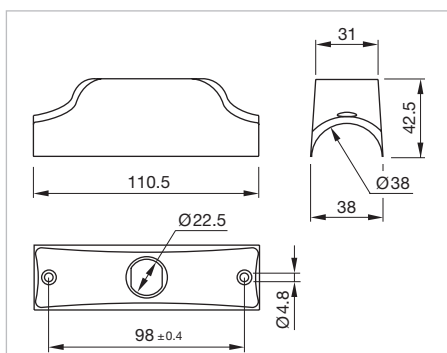

Dimensions [mm]



Housing wall mounting

Material	Colour	Mounting cut-out	Part No.
Plastic	Yellow	Ø 22.5 mm	84-9800.4
	Grey	Ø 22.5 mm	84-9800.8

Additional information

- Screws are not contained in the scope of supply

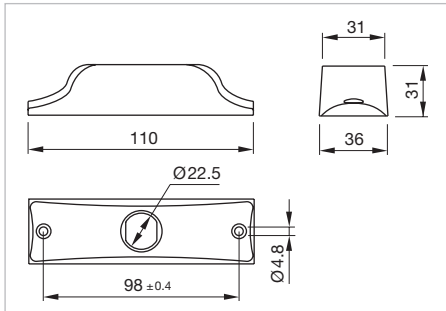

Dimensions [mm]



Cable gland

Product attributes	Material	Colour	IP Protection	Thread	Part No.
With traction relief	Plastic	Grey	IP68	M16 x 1.5 mm	61-9481.6
	Plastic	Grey	IP68	M20 x 1.5 mm	704.945.6



Mounting tool

Product attributes	Dimension	Material	Part No.
For tightening or loosening the fixing nut, for emergency-stop and stop-switch		Plastic	84-996
For tightening or loosening of the fixing nut Ø 22 mm, for Part No. 82-903	Ø 22 mm	Metal	84-997

Emergency-stop

Switching system

The double-break switching system can be supplied for the following switching functions:

1 Normally closed, 2 Normally closed, 1 Normally closed + 1 Normally open.

The Normally closed contacts have forced opening according to EN 60947-5-5

Material

Connection cable

Plastic, operating temperature up to +65 °C

Mushroom-head cap

Plastic, as per UL 94 V0

Actuator housing

Plastic, as per UL 94 V0

Material of contact

Silver alloy gold plated

Mechanical characteristics

Front panel thickness

Standard 1 ... 4 mm
with emergency stop protective shroud Part No. 84-902 1 ... 3 mm

Mounting cut-outs

Ø22.3 mm as per EN IEC 60947-5-1 with anti-twist device

Terminals

Soldering terminals 2.8 mm x 0.5 mm (solderable), CuSn6 tin-plated
Flat ribbon cable 2-, 4-, or 6-poles 0.35 mm² (AWG 22)

Tightening torque

Fixing nut 0.8 Nm

Actuating force

17 N ± 4 N

Actuating travel

Approx. 5 mm

Mechanical lifetime

250 000 cycles of operations

Electrical characteristics

Standards

The devices comply with: EN IEC 60947-5-1, EN IEC 60947-5-5 (emergency stop), DIN EN ISO 13850, EN IEC 60204

Illumination

LED red with pole reversal, constant current source
Operation Voltage 5 VDC ... 30 VDC
Current consumption 9.7 mA ... 12.4 mA

Rated Operational Voltage U_o

250 VAC, as per EN IEC 60947-1

Rated Insulation Voltage U_i

250 V, as per EN IEC 60947-1

Rated Impulse Withstand Voltage U_{imp}

4 kV, as per EN IEC 60947-1

Electrical life

50 000 cycles of operations
(inductive $\cos\phi$ 0,95) as per EN IEC 60947-5-1

Air thermal I_{th}

5 A (plug in)
3 A (cable leads)

Switching voltage and switching current

Switch rating AC with silver contact (gold plated), service category AC-15, as per EN IEC 60947-5-1

Voltage	120 VAC	240 VAC
Current	3 A	1.5 A

Switch rating DC for silver contact (gold plated), service category DC-13, as per EN IEC 60947-5-1

NO contacts (48 VA)	NC contacts (60 VA)	NO/NC contacts
12 VDC/2.0 A	12 VDC/2.5 A	125 VDC/0.22 A
24 VDC/2.0 A	24 VDC/2.5 A	250 VDC/0.11 A
48 VDC/1.0 A	48 VDC/1.25 A	
60 VDC/0.8 A	60 VDC/1.0 A	

Recommended minimum operating data

Silver contacts (gold plated)

Voltage	1 VAC/DC
Current	1 mA

Electric strength

500 VAC, 50 Hz, 1 minute, as per DIN IEC 60512-2

Rated conditional short-circuit current

1000 A, type of short-circuit unit 6 A gG, as per EN IEC 60947-5-1

Protection class

Class II, as per EN IEC 60947-5

Overvoltage category

III, as per EN IEC 60947-1

Degree of pollution

3, as per EN IEC 60947-1

Ambient conditions

Storage temperature

-25 °C ... +80 °C

Operating temperature

-25 °C ... +65 °C

Front protection

IP65 front side, as per EN IEC 60529

IP66 front side, as per EN IEC 60529

IP67 front side, as per EN IEC 60529

IP20 (cable lead connection)

Impact resistance

IK07, as per IEC 62262

Shock resistance

(semi-sinusoidal)

Max. 150 m/s², pulse width 11 ms, 3-axis,

as per EN IEC 60068-2-27

Vibration resistance

(sinusoidal)

Max. 50 m/s² at 10 Hz ... 500 Hz, 10 cycles, 3-axis,

as per EN IEC 60068-2-6

Climate resistance

Damp heat, cyclic

96 hours, +25 °C/97 %, +55 °C/93 % relative humidity, as per EN IEC 60068-2-30

Damp heat, steady

56 days, +40 °C/93 % relative humidity,

as per EN IEC 60068-2-78

Dry heat

96 hours, +65 °C, as per EN IEC 60068-2-2

Low temperature

96 hours, -25 °C, as per EN IEC 60068-2-1

Saline mist

96 hours, +35 °C in chemical solution NaCl,

as per EN IEC 60068-2-11

Approvals

Approbations

CB (IEC 60947-5-1, IEC 60947-5-5)

UL NISD

CCC (pending)

Declaration of conformity

CE

UKCA

2006/42/EC (MD)

2011/65/EC (RoHS)

Switching element illuminated pushbutton

Switching system

Short-travel switching system with 2 independent contact points and tactile operation.

Guarantees reliable switching even of very light loads.

Fitted with 1 normally open contact.

Material

Connection cable

Plastic, short-time heat-resistant up to 105 °C

Material of contact

Silver alloy gold plated

Switching element

Plastic, as per UL 94 V0 and

Plastic, as per UL 94 HB

Mechanical characteristics

Terminals

Plug-in terminals 2.8 mm x 0.8 mm (solderable)

Flat ribbon cable 0.5 mm²

PCB terminal

Actuating force

4.0 N ±0.2 N

Tightening torque

Fixing screw mounting flange 0.4 Nm

Actuating travel

~0.5 mm

Resistance to heat of soldering

250 °C, 3 s (PCB assembly)

320 °C, 3 s (when using a soldering iron)

84 Technical data

Mechanical lifetime

≥ 1 million cycles of operations

Electrical characteristics

Illumination

Single-Chip LED, green, orange, red, yellow, white and blue

Operation Voltage 12 VDC 24 VDC

Current consumption 10 mA 10 mA

Electrical life

as per EN IEC 60512-5

5 million cycles of operation	24 VAC, 50 mA at 480 Ω
5 million cycles of operation	24 VAC, 100 mA at 240 Ω
2 million cycles of operation	42 VAC, 50 mA at 840 Ω
2 million cycles of operation	42 VAC, 100 mA at 420 Ω
300 000 cycles of operation	42 VAC, 100 mA at $\cos\varphi$ 0.4
250 000 cycles of operation	42 VAC, 200 mA at $\cos\varphi$ 0.395
1 million cycles of operation	12 VDC, 250 mA at 48 Ω
1 million cycles of operation	24 VDC, 50 mA at 480 Ω
1 million cycles of operation	24 VDC, 100 mA at 240 Ω
5 million cycles of operation	42 VDC, 25 mA at 1680 Ω
1.5 million cycles of operation	42 VDC, 50 mA at 840 Ω
100 000 cycles of operation	42 VDC, 100 mA at 420 Ω
500 000 cycles of operation	24 VDC, 200 mA at L/R = 30 ms
300 000 cycles of operation	42 VDC, 100 mA at L/R = 30 ms
100 000 cycles of operation	42 VDC, 200 mA at L/R = 30 ms

Switching voltage and switching current

Voltage 50 mVAC/DC ... 42 VAC/DC

Current 10 µA ... 100 mA

Power max. 2 W

Electric strength

500 VAC, 50 Hz, 1 minute, as per DIN IEC 60512-2

Ambient conditions

Storage temperature

-40 °C ... +85 °C

Operating temperature

-25 °C ... +70 °C

Protection degree

Back protection:

IP40, standard version

IP67, fully sealed version, with mounted actuator only.

Shock resistance

(semi-sinusoidal)

Max. 100 m/s², pulse width 11 ms, 3-axis,

as per EN IEC 60068-2-27

Vibration resistance

(sinusoidal)

Max. 50 m/s² at 10 Hz ... 500 Hz, 10 cycles, 3-axis,

as per EN IEC 60068-2-6

Switching element Halo Compact

Switch configuration

A complete switch requires a halo compact programmable switch actuator body (transparent) and a lens. If the switch needs lens illumination in addition then a translucent plastic lens or aluminium lens with a window is required.

Use Halo Compact with illuminated pushbutton actuator (Part No. 84-1081.7) or with the indicator actuator (Part No. 84-0080.7).

The illumination style is selected by the connection of 24V to the pins.

Material

Housing

Plastic

Plastic (sealing compound)

Material of contact

Silver alloy, gold-plated

The materials used comply with the high EAO standards relating to quality, functional safety, service life and design.

Mechanical characteristics

Terminals

Soldering/plug-in terminals

2.8 mm x 0.8 mm (solderable)

Actuating force

4.0 N ± 0.2 N

(measured at the lens)

Actuating distance

~ 0.5 mm

Mechanical lifetime

≥ 1 million cycles of operation

Electrical characteristics

Switching element

Short-travel snap-action switching system with two independent contact points and tactile operation.

Number of contacts: one normal open contact

Output

Electronic high-side switch

Pre-configured light sequences

- Full illumination
- Blinking (interval: 1 second)
- Rotating/chasing (one full rotation per second)
- Process (changeover a group of 4 LEDs per second)

Special feature

Integrated electronic switch for maintained action (High-side switch)

Operating voltage

24VDC ± 10 %

Max. 100 mA

Current consumption

< 80 mA

LED-colours

All versions available with eight SMD LEDs for halo illumination plus one single LED (3mm) for central illumination. The following variants are available:

- 8 x red LEDs + 1 white single LED
- 8 x green LEDs + 1 white single LED
- 8 x yellow LEDs + 1 white single LED
- 8 x white LEDs + 1 white single LED
- 8 x blue LEDs + 1 white single LED
- 8 x red/green bi-colour LEDs + 1 white single LED

Light sequences central LED		IN1	IN2	IN3
not illuminated	illuminated			
1	–	0VDC	0VDC	0VDC
2	–	+24VDC	0VDC	0VDC
3	–	0VDC	+24VDC	0VDC
4	–	+24VDC	+24VDC	0VDC
–	5	0VDC	0VDC	+24VDC
–	6	+24VDC	0VDC	+24VDC
–	7	0VDC	+24VDC	+24VDC
–	8	+24VDC	+24VDC	+24VDC

* Functionen of light sequence:

1/5 = Full illumination

2/6 = Blink

3/7 = Rotation

4/8 = Process

Ambient conditions

Storage temperature

–40 °C ... +85 °C

Operating temperature

–25 °C ... +70 °C

Degree of protection

IP67 front side

(with actuator Part No. 84-1081.7 and 84-0080.7)

Shock resistance

(semi-sinusoidal)

Max. 100 m/s², pulse width 6 ms, 3-axis, as per EN IEC 60068-2-27

Vibration resistance

(sinusoidal)

Max. 50 m/s² at 10 Hz... 500 Hz, 10 cycles, 3-axis, as per EN IEC 60068-2-6

Approvals

Conformities

CE

UKCA

2014/30/EU (EMC)

2011/65/EC (RoHS)

Actuator

Material

Lens

Plastic, as per UL 94 V2 or Aluminium anodised

Actuator housing

Plastic, as per UL 94 V0 or Aluminium anodised

Mechanical characteristics

Frontplate thickness

Standard 1 ... 4 mm

Tightening torque

Fixing nut max. 80 Ncm

Actuating force

4.0 N \pm 0.2 N (measured at the lens)

Actuating travel

1.2 mm

Mechanical lifetime

\geq 1 million cycles of operation

Electrical characteristics

Electrostatic breakdown value

Plastic case \geq 15 kV

Aluminium case \geq 5 kV

as per IEC 61000-4-2, mounted in plastic front panel

Ambient conditions

Storage temperature

-40 °C ... +85 °C

Operating temperature

-25 °C ... +70 °C

Protection degree

IP 67 and IP40 front side, as per EN IEC 60529

Climate resistance

Damp heat, cyclic

96 hours, +25 °C/97 %, +55 °C/93 % relative humidity, as per EN IEC 60068-2-30

Damp heat, state

56 days, +40 °C/93 % relative humidity, as per EN IEC 60068-2-78

Rapid change of temperature

100 cycles, -40 °C ... +80 °C, as per EN IEC 60068-2-14

Approvals

Approbations

EBC (TSI/PRM)

NFF

Conformities

CE

UKCA













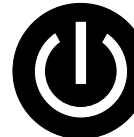
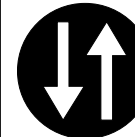

2011/65/EC (RoHS)

EAO reserves the right to alter specifications without further notice.

IO-Link Touch – Standard Symbols

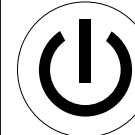
Please note

- BXX symbols are illuminated
- CXX symbols are printed on
- Further standard symbols and also customised symbols possible

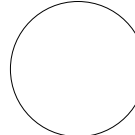
 Symbol B10	 Symbol B11	 Symbol B12	 Symbol B13	 Symbol B14	 Symbol B15
 Symbol C10	 Symbol C11	 Symbol C12	 Symbol C13	 Symbol C14	 Symbol C16
 Symbol C17	 Symbol C18	 Symbol C19	 Symbol C20		

84 Application guidelines

Suppressor circuits

When switching inductive loads such as relays, DC motors, and DC solenoids, it is always important to absorb surges (e.g. with a diode) to protect the contacts. When these inductive loads are switched off, a counter emf can severely damage switch contacts and greatly shorten lifetime.

Fig. 1 shows an inductive load with a free-wheeling diode connected in parallel. This free-wheeling diode provides a path for the inductor current to flow when the current is interrupted by the switch. Without this free-wheeling diode, the voltage across the coil will be limited only by dielectric breakdown voltages of the circuit or parasitic elements of the coil. This voltage can be kilo-

volts in amplitude even when nominal circuit voltages are low (e.g. 12 VDC) see Fig. 2.

The free-wheeling diode should be chosen so that the reverse breakdown voltage is greater than the voltage driving the inductive load. The DC blocking voltage (VR) of the free-wheeling diode can be found in the datasheet of a diode. The forward current should be equal or greater than the maximum current flowing through the load.

To get an efficient protection, the free-wheeling diode must be connected as close as possible to the inductive load!

Switching with inductive load

Fig. 1

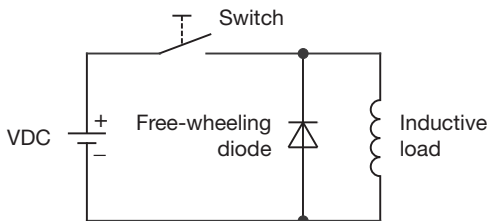

Counter EMF over load without free-wheeling diode

Fig. 2

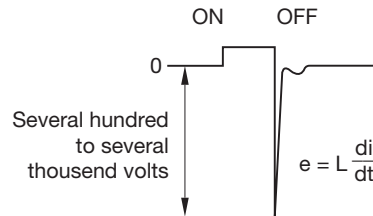

Note for soldering

Process parameter for wave soldering

Basic specification for wave soldering J-STD 75 W4C.

Maximum temperature on the component side (Temp 2): (Temperature must not exceed during the entire processing)	120 °C
Preheating phase (t1 ... t2):	70 ... 120 sec
Ramp up:	typ. +1 °C/sec
Ramp up to maximum temperature (t2 ... t3):	not defined
Maximum temperature on the soldering side (Temp 3):	250 °C
Maximum time of soldering process (t3 ... t4):	3 sec
Ramp down at 170 °C:	typ. -2 °C/sec

Temperature curve wave soldering

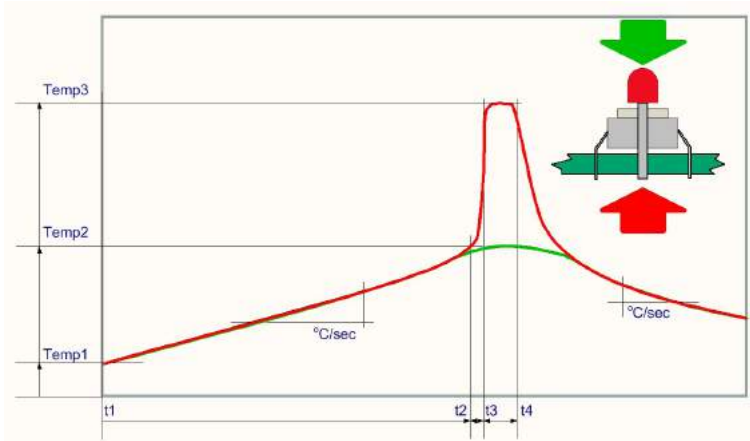

Green curve:	Temperature on the component side of the pcb
Red curve:	Temperature on the soldering side of the pcb
Room temperature:	Temp 1
Preheating:	Temperature process = Temp 1 ... Temp 2 Process time = t1 ... t2
Ramp up to soldering temperature:	Process time = t2 ... t3
Soldering phase:	Temperature process = Temp 3 Process time = t3 ... t4

Iron soldering

Basic specification for iron soldering IEC 60068-2-20

Maximum temperature at tip of iron:	320 °C
Maximum soldering time:	3 sec

Cleaning/Lacquering

The switching elements are not sealed. Cleaning up the PCB may damage the contacts in the switching elements. For this reason, the following points should be noted:

- When soldering make sure that the flux does not pass on the upper side of the PCB.
- When cleaning the PCB with detergents ensure that no dust or other debris may get inside of the switching elements.
- Ensure that no lacquer penetrates into the interior of the switching element when lacquering the PCB.

Storage of components

To obtain the optimum solderability of the components, the following points should be noted during storage:

- Do not store components in locations with high temperature or humidity.
- Do not expose components to corrosive gases.
- Avoid direct sunlight for a long period.

84 Application guidelines

Arrangement mounting flange for switching- and illumination element, PCB mounting

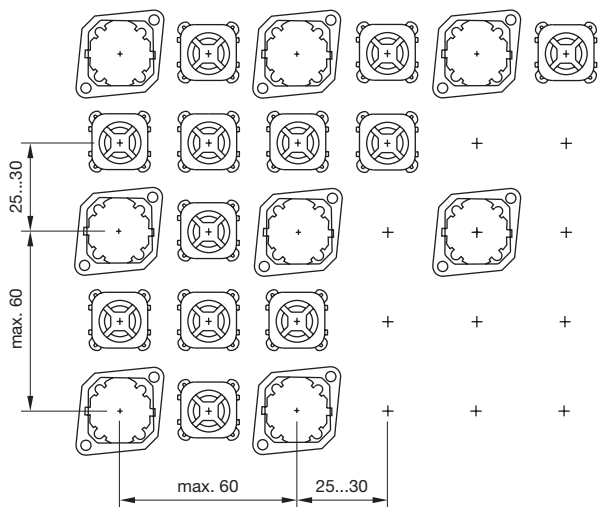

The arrangement of the mounting flanges and their number is determined by the size of the front panel or PCB. To ensure uniform, tactile switching, we recommend a layout of the flanges as per adjacent sketch.

For large PCBs with several switching elements we recommend the following procedure:

1. Fit the actuator to the front panel.
2. Clip the mounting flange to the rear of the intended actuator.
3. Screw the PCB with the components soldered to it to the assembled mounting flange.

This arrangement applies to PCBs 1.6mm thick.

Dismantling mounting flange

The tool Part No. 84-998 must be used for removing the mounting flange from the actuator.

Before removing the flange, the PCB fixing screws must be loosened.

Part No.	Page	Part No.	Page	Part No.	Page	Part No.	Page	Part No.	Page
10-2601.3172S.....	41	84-2101.0.....	6	84-7114.600A.....	40	84-8511.2620.....	42	84-ADKS-B11-04AB...24	
10-2601.3173S.....	41	84-2101.0.....	12	84-7115.200.....	38	84-8511.2640.....	43	84-ADKS-B12-04AC..24	
10-2603.3174S.....	41	84-2101.0.....	14	84-7115.300.....	38	84-8511.3320.....	42	84-ADKS-B13-04AD..24	
10-2603.3175S.....	41	84-3100.0.....	16	84-7115.400.....	38	84-8511.3620.....	42	84-ADKS-B14-04AE..24	
10-2603.3176S.....	41	84-3100.0.....	17	84-7115.500.....	38	84-8511.3640.....	43	84-ADKS-B15-04AF...24	
10-2603.3178S.....	41	84-3103.0000.1.....	36	84-7115.600.....	38	84-8511.4320.....	42	84-ADKS-C10-04B0...24	
10-2603.320AL.....	41	84-3103.0000.2.....	36	84-7115.700.....	38	84-8511.4340.....	43	84-ADKS-C11-04B1...24	
10-2603.320CL.....	41	84-5220.0020.....	31	84-7121.000.....	38	84-8511.4620.....	42	84-ADKS-C12-04B2...24	
31-929.....	55	84-5220.0040.....	31	84-7121.800.....	38	84-8511.4640.....	43	84-ADKS-C14-04B3...24	
61-9453.0.....	53	84-5221.2B20.....	31	84-7124.000A.....	40	84-8511.5320.....	42	84-ADKS-C16-04B4...24	
61-9481.6.....	59	84-5221.2B40.....	31	84-7124.200A.....	40	84-8511.5340.....	43	84-ADKS-C17-04B5...24	
61-9707.7.....	40	84-5230.0020.....	31	84-7125.000.....	38	84-8511.5620.....	42	84-ADKS-C18-04B6...24	
61-9980.0.....	52	84-5230.0040.....	31	84-7125.800.....	38	84-8511.5640.....	43	84-ADKS-C19-04B7...24	
704.945.1.....	57	84-5231.2B20.....	31	84-7201.000.....	39	84-8511.6320.....	42	84-ADKS-C20-04B8...24	
704.945.2.....	57	84-5231.2B40.....	31	84-7201.200.....	39	84-8511.6340.....	43	84-ASKS-B10-049C...22	
704.945.3.....	57	84-5240.0020.....	31	84-7201.400.....	39	84-8511.6620.....	42	84-ASKS-B11-049D...22	
704.945.4.....	57	84-5240.0040.....	31	84-7201.500.....	39	84-8511.6640.....	43	84-ASKS-B12-049E...22	
704.945.5.....	57	84-5241.2B20.....	31	84-7201.600.....	39	84-8511.9320.....	42	84-ASKS-C16-049F...22	
704.945.6.....	59	84-5241.2B40.....	32	84-7201.800.....	39	84-8511.9340.....	43	84-ASKS-B14-04A0...22	
704.963.0.....	53	84-5241.8D20.....	34	84-7202.000.....	39	84-8511.9620.....	42	84-ASKS-B15-04A1...22	
704.963.1.....	53	84-5241.8D40.....	34	84-7202.000A.....	37	84-8511.9640.....	43	84-ASKS-C10-04A2...22	
704.963.2.....	53	84-5320.0020.....	32	84-7202.200.....	39	84-8515.7640.....	44	84-ASKS-C11-04A3...22	
704.963.3.....	53	84-5320.0040.....	32	84-7202.200A.....	37	84-8515.8640.....	44	84-ASKS-C12-04A4...22	
704.963.4.....	53	84-5321.2B20.....	32	84-7202.500.....	39	84-8716.2620.....	49	84-ASKS-C14-04A5...22	
704.963.5.....	53	84-5321.2B40.....	32	84-7202.600A.....	37	84-8716.4620.....	49	84-ASKS-C16-04A6...22	
704.963.6.....	53	84-5330.0020.....	32	84-7202.800.....	39	84-8716.5620.....	49	84-ASKS-C17-04A7...22	
704.963.7.....	53	84-5330.0040.....	32	84-7202.800A.....	37	84-8716.6620.....	49	84-ASKS-C18-04A8...22	
704.963.8.....	53	84-5331.2B20.....	32	84-7205.000A.....	37	84-8716.8620.....	49	84-ASKS-C19-04A9...22	
704.963.9.....	53	84-5331.2B40.....	32	84-7205.200.....	39	84-8716.9620.....	49	84-ASKS-C20-049B...22	
704.964.8.....	53	84-5340.0020.....	32	84-7205.200A.....	37	84-900.....	56	92-800.042.....50	
704.968.0.....	52	84-5340.0040.....	32	84-7205.500A.....	37	84-901.....	57	92-851.342.....45	
704.968.1.....	52	84-5341.2B20.....	32	84-7205.600A.....	37	84-902.....	54	92-960.0.....51	
84-0080.7.....	20	84-5341.2B40.....	32	84-7205.800.....	39	84-902A.....	54		
84-0080.7.....	21	84-5341.8D20.....	34	84-7205.800A.....	37	84-902B.....	54		
84-0090.7.....	18	84-5341.8D40.....	34	84-7205.804A.....	37	84-902D.....	54		
84-0090.7.....	19	84-5520.0020.....	32	84-7205.805A.....	37	84-905.....	57		
84-0100.0.....	16	84-5530.0020.....	32	84-7205.806A.....	37	84-906.....	54		
84-0100.0.....	17	84-5540.0020.....	32	84-7205.808A.....	37	84-908.....	57		
84-0200.7.....	16	84-5520.0040.....	32	84-7211.000.....	40	84-909.....	54		
84-0200.7.....	17	84-5530.0040.....	32	84-7211.200.....	40	84-910.....	57		
84-1081.7.....	10	84-5540.0040.....	32	84-7211.400.....	40	84-9103.7.....	53		
84-1081.7.....	11	84-6220.0020.....	28	84-7211.500.....	40	84-911.....	57		
84-1091.7.....	8	84-6220.0040.....	28	84-7211.600.....	40	84-916.....	54		
84-1091.7.....	9	84-6221.2B20.....	28	84-7211.800.....	40	84-918.....	57		
84-1101.0.....	4	84-6221.2B40.....	28	84-7215.000.....	40	84-920.....	56		
84-1101.0.....	6	84-6230.0020.....	28	84-7215.200.....	40	84-922.....	54		
84-1101.0.....	12	84-6230.0040.....	28	84-7215.400.....	40	84-9300.4.....	55		
84-1101.0.....	14	84-6231.2B20.....	28	84-7215.500.....	40	84-9300.8.....	55		
84-1201.0.....	4	84-6231.2B40.....	28	84-7215.600.....	40	84-9420.....	55		
84-1201.0.....	6	84-6240.0020.....	28	84-7215.800.....	40	84-9500.4.....	58		
84-1201.0.....	12	84-6240.0040.....	28	84-8001.2320.....	46	84-9500.6A.....	58		
84-1201.0.....	14	84-6241.2B20.....	28	84-8001.2340.....	47	84-9500.8.....	58		
84-1201.2.....	4	84-6241.2B40.....	29	84-8001.2620.....	46	84-960.0.....	51		
84-1201.2.....	6	84-6330.0040.....	29	84-8001.2640.....	47	84-9600.4.....	58		
84-1201.2.....	12	84-6331.2B20.....	29	84-8001.3620.....	46	84-9600.8.....	58		
84-1201.2.....	14	84-6331.2B40.....	29	84-8001.3640.....	47	84-9700.4.....	55		
84-1201.4.....	4	84-6340.0040.....	29	84-8001.4320.....	46	84-9700.8.....	55		
84-1201.4.....	6	84-6341.2B20.....	29	84-8001.4340.....	47	84-9800.4.....	59		
84-1201.4.....	12	84-6341.2B40.....	29	84-8001.4620.....	46	84-9800.8.....	59		
84-1201.4.....	14	84-7111.200.....	38	84-8001.4640.....	47	84-996.....	59		
84-1201.5.....	4	84-7111.201.....	39	84-8001.5320.....	46	84-997.....	59		
84-1201.5.....	6	84-7111.300.....	38	84-8001.5340.....	47	84-ACKS-B10-04B9...26			
84-1201.5.....	12	84-7111.301.....	39	84-8001.5620.....	46	84-ACKS-B11-04BA..26			
84-1201.5.....	14	84-7111.400.....	38	84-8001.5640.....	47	84-ACKS-B12-04BB..26			
84-1201.6.....	4	84-7111.401.....	39	84-8001.6320.....	46	84-ACKS-B13-04BC..26			
84-1201.6.....	6	84-7111.500.....	38	84-8001.6620.....	46	84-ACKS-B14-04BD..26			
84-1201.6.....	12	84-7111.501.....	39	84-8001.6640.....	47	84-ACKS-B15-04BE..26			
84-1201.6.....	14	84-7111.502.....	39	84-8001.9320.....	46	84-ACKS-C10-04BF...26			
84-1201.7.....	4	84-7111.503.....	39	84-8001.9340.....	47	84-ACKS-C11-04C0...26			
84-1201.7.....	6	84-7111.600.....	38	84-8001.9620.....	46	84-ACKS-C12-04C1...26			
84-1201.7.....	12	84-7111.601.....	39	84-8001.9640.....	47	84-ACKS-C14-04C2...26			
84-1201.7.....	14	84-7111.602.....	39	84-8005.8620.....	48	84-ACKS-C16-04C3...26			
84-1221.7.....	5	84-7111.603.....	39	84-8005.8640.....	48	84-ACKS-C17-04C4...26			
84-1221.7.....	6	84-7111.700.....	38	84-8510.0020.....	44	84-ACKS-C18-04C5...26			
84-1221.7.....	13	84-7111.701.....	39	84-8510.0040.....	44	84-ACKS-C19-04C6...26			
84-1221.7.....	14	84-7111.702.....	39	84-8511.2320.....	42	84-ACKS-C20-04C7...26			
84-2101.0.....	4	84-7111.703.....	39	84-8511.2340.....	43	84-ADKS-B10-04AA...24			

