



FERRITE CORES

Toroids • Shapes • Pot Cores

Part Number Index

| TOROIDS | | | | E CORES | | | | | | SHAPES | | | | |
|---------|----|---------|----|---------|----|-------------|----|------------|----|--------------|----|--------------|-----------|--|
| TOROID | PG | TOROID | PG | E, I | PG | PLANAR E, I | PG | EC | PG | U, I | PG | Pot | | |
| 40200TC | 20 | 44416TC | 24 | 40904EC | 28 | 41425EC | 32 | 43517EC | 42 | 41106UC | 38 | 40704UG | 54 | |
| 40301TC | 20 | 44419TC | 24 | 41203EC | 28 | 41434EC | 32 | 44119EC | 42 | 41106IC | 38 | 40905UG | 54 | |
| 40401TC | 20 | 44715TC | 24 | 41205EC | 28 | 41434IC | 32 | 45224EC | 42 | 42220UC | 38 | 41107UG | 54 | |
| 40402TC | 20 | 44916TC | 26 | 41707EC | 28 | 41805EC | 32 | 47035EC | 42 | 42512UC | 38 | 41109UG | 54 | |
| 40502TC | 20 | 44920TC | 26 | 41808EC | 28 | 41805IC | 32 | EER | | 42515UC | 38 | 41408UG | 54 | |
| 40503TC | 20 | 44925TC | 26 | 41810EC | 28 | 42107EC | 32 | 42814EC | 44 | 42516IC | 38 | 41811UG | 54 | |
| 40601TC | 20 | 44932TC | 26 | 42510EC | 28 | 42107IC | 32 | 42817EC | 44 | 42530UC | 38 | 41814UG | 54 | |
| 40603TC | 20 | 46013TC | 26 | 42513EC | 28 | 42214EC | 32 | 43521EC | 44 | 49316UC | 38 | 42213UG | 54 | |
| 40705TC | 20 | 46019TC | 26 | 42515EC | 28 | 42214IC | 32 | 44013EC | 44 | 49316IC | 38 | 42438UG | 54 | |
| 40907TC | 20 | 46113TC | 26 | 42520EC | 28 | 42216EC | 32 | 44216EC | 44 | 49330UC | 38 | 42616UG | 54 | |
| 41003TC | 20 | 46325TC | 26 | 42526EC | 28 | 42216IC | 32 | 44818EC | 44 | 49332UC | 38 | 42823UG | 54 | |
| 41005TC | 20 | 46326TC | 26 | 42530EC | 28 | 42217EC | 32 | 44821EC | 44 | 49920UC | 38 | 43019UG | 54 | |
| 41206TC | 20 | 47313TC | 26 | 43007EC | 28 | 43208EC | 32 | 45418EC | 44 | 49925UC | 38 | 43622UG | 54 | |
| 41303TC | 20 | 47325TC | 26 | 43009EC | 28 | 43208IC | 32 | EFD | | 49925IC | 38 | 44229UG | 54 | |
| 41304TC | 20 | 47326TC | 26 | 43515EC | 28 | 43618EC | 32 | 41009EC | 46 | UR | | RS-DS | PG | |
| 41305TC | 20 | 48613TC | 26 | 43520EC | 28 | 43618IC | 32 | 41212EC | 46 | 44119UC | 40 | 41408UG | 56 | |
| 41306TC | 20 | 48619TC | 26 | 44011EC | 30 | 43808EC | 34 | 41515EC | 46 | 44121UC | 40 | 41811UG | 56 | |
| 41405TC | 22 | 48625TC | 26 | 44016EC | 30 | 43808IC | 34 | 42019EC | 46 | 44125UC | 40 | 42311UG | 56 | |
| 41406TC | 22 | 48626TC | 26 | 44020EC | 30 | 43809EC | 34 | 42523EC | 46 | 44130UC | 40 | 42318UG | 56 | |
| 41407TC | 22 | 49715TC | 26 | 44020IC | 30 | 44008EC | 34 | 43030EC | 46 | 45716UC | 40 | 42616UG | 56 | |
| 41410TC | 22 | 49718TC | 26 | 44022EC | 30 | 44008IC | 34 | ETD | | 45917UC | 40 | 43019UG | 56 | |
| 41435TC | 22 | 49725TC | 26 | 44033EC | 30 | 44308EC | 34 | 42929EC | 48 | 46420UC | 40 | 43622UG | 56 | |
| 41450TC | 22 | 49740TC | 26 | 44317EC | 30 | 44308IC | 34 | 43434EC | 48 | BLOCK | | 44229UG | 56 | |
| 41506TC | 22 | | | 44721EC | 30 | 44310EC | 34 | 43939EC | 48 | 41106IC | 50 | PQ | | |
| 41605TC | 22 | | | 45528EC | 30 | 44310IC | 34 | 44444EC | 48 | 41308IC | 50 | 42016UG | 58 | |
| 41606TC | 22 | | | 45530EC | 30 | 45810EC | 34 | 44949EC | 48 | 41805IC | 50 | 42020UG | 58 | |
| 41607TC | 22 | | | 45724EC | 30 | 45810IC | 34 | 45454EC | 48 | 42014IC | 50 | 42610UG | 58 | |
| 41610TC | 22 | | | 46016EC | 30 | 46410EC | 34 | 45959EC | 48 | 42107IC | 50 | 42614UG | 58 | |
| 41809TC | 22 | | | 46022EC | 30 | 46410IC | 34 | 47054EC | 48 | 42216IC | 50 | 42620UG | 58 | |
| 42106TC | 22 | | | 46527EC | 30 | 49938EC | 34 | | | 42516IC | 50 | 42625UG | 58 | |
| 42109TC | 22 | | | 47133EC | 30 | ER | | | | 43208IC | 50 | 43214UG | 58 | |
| 42206TC | 22 | | | 47228EC | 30 | 40906EC | 36 | | | 43618IC | 50 | 43220UG | 58 | |
| 42207TC | 22 | | | 48020EC | 30 | 41126EC | 36 | | | 43808IC | 50 | 43230UG | 58 | |
| 42212TC | 22 | | | 49928EC | 30 | 41308EC | 36 | | | 44008IC | 50 | 43535UG | 58 | |
| 42506TC | 22 | | | | | 41308IC | 36 | | | 44020IC | 50 | 44040UG | 58 | |
| 42507TC | 22 | | | | | 41426EC | 36 | | | 44308IC | 50 | 45050UG | 58 | |
| 42508TC | 22 | | | | | 41826EC | 36 | | | 44310IC | 50 | RM | | |
| 42712TC | 24 | | | | | 42014EC | 36 | | | 45810IC | 50 | 41110UG | 60 | |
| 42908TC | 24 | | | | | 42014IC | 36 | | | 46410IC | 50 | 41510UG | 60 | |
| 42915TC | 24 | | | | | 42313EC | 36 | | | 49316IC | 50 | 41812UG | 60 | |
| 43113TC | 24 | | | | | 42517EC | 36 | | | 49925IC | 50 | 41912UG | 60 | |
| 43205TC | 24 | | | | | 42517IC | 36 | | | 49938FB | 50 | 42013UG | 60 | |
| 43610TC | 24 | | | | | 42521EC | 36 | | | 49966FB | 50 | 42316UG | 60 | |
| 43615TC | 24 | | | | | 43021EC | 36 | | | 49985FB | 50 | 42819UG | 60 | |
| 43620TC | 24 | | | | | 43021IC | 36 | | | EP | | 43723UG | 60 | |
| 43806TC | 24 | | | | | 43225EC | 36 | | | 40707UG | 52 | 44230UG | 60 | |
| 43813TC | 24 | | | | | | | | | 41010UG | 52 | | | |
| 43825TC | 24 | | | | | | | | | 41313UG | 52 | | | |
| 44015TC | 24 | | | | | | | | | 41717UG | 52 | | | |
| | | | | | | | | | | 42120UG | 52 | | | |

Index

| | | | |
|---|-------------------------------|--|---------------------------|
| | Applications & Materials 2-15 |  | EFD Cores..... 46-47 |
| | Gapped Cores..... 16-19 |  | ETD Cores 48-49 |
|  | Toroids 20-27 |  | Block Cores..... 50-51 |
|  | E, I Cores..... 28-31 |  | EP Cores..... 52-53 |
|  | Planar E, I Cores 32-35 |  | Pot Cores..... 54-55 |
|  | ER Cores..... 36-37 |  | RS/DS Cores 56-57 |
|  | U, I Cores 38-39 |  | PQ Cores 58-59 |
|  | UR Cores 40-41 |  | RM Cores..... 60-61 |
|  | EC Cores..... 42-43 |  | Hardware 62 |
|  | EER Cores 44-45 | | Design Guides 63-67 |

Applications & Materials



Ferrites are dense, homogenous ceramic structures made by mixing iron oxide with oxides or carbonates of one or more metals such as zinc, manganese, nickel or magnesium. They are pressed, then fired in a kiln at 1,000 - 1,500°C and machined as needed to meet various operational requirements. Ferrite parts can be easily and economically molded into many different geometries. A diverse set of materials, providing a range of desired electrical and mechanical properties, are available from Magnetics.

Magnetics' ferrite cores are manufactured for a wide variety of applications. Magnetics has the leading MnZn ferrite materials for power transformers, power inductors, wide-band transformers, common mode chokes, as well as many other applications.

ADVANTAGES OF MAGNETICS' FERRITES

- The widest range of toroid sizes in power and high permeability materials
- Superior toroid coatings available in epoxy and Parylene C
- Standard gapping to precise inductance or mechanical dimension: wide range of coil former and assembly hardware available
- The full range of standard planar E and I cores
- Rapid prototyping capability for new development

FERRITE APPLICATIONS

| APPLICATIONS | DESIRED PROPERTIES | PREFERRED MATERIALS | AVAILABLE SHAPES |
|-------------------------------------|---|---------------------|---|
| Broadband Transformers | Low loss, high μ . Good frequency response. | J, W, M | Pot cores, Toroids, E, U & I cores, RM cores, EP cores |
| Common Mode Chokes | Very high μ (permeability). | J, W, M | Toroids, E Cores |
| Converter and Inverter Transformers | Low losses, high saturation. | F, L, P, R, T | Toroids, E, U & I cores, Pot cores, RS cores, Planar cores |
| Differential Mode Inductors | Low losses, high temperature stability, good stability across load conditions. | F, P, R, T | Gapped Pot cores, EP cores, E cores, RM cores, Planar cores, PQ cores |
| Linear Filters and Sensors | Good loss factor, linearity and temperature linearity at low drive level. | C, E, V | Pot cores, Toroids |
| Narrow Band Transformers | Moderate Q, high μ , high stability. | F, J | Pot cores, Toroids, RM cores, EP cores |
| Noise Filters | High μ , good frequency response. | J, W, M | Toroids |
| Power Inductors | Low losses at high flux densities and temperatures. High saturation. Good stability across load conditions. | F, L, P, R, T | Pot cores, E cores, PQ cores, RM cores, Planar cores |
| Power Transformers | High μ and low losses at high flux densities and temperatures. High saturation. Low exciting currents. | F, L, P, R, T | Ungapped Pot cores, E, U & I cores, Toroids, EP cores, RS cores, DS cores, PQ cores, Planar cores |
| Pulse Transformers | High μ , low loss, high B saturation. | J, W, M | Toroids |
| Telecom Inductors | Low losses, high temperature stability, good stability across load conditions. | F, P, R, T | Pot cores, EP cores, E cores, RM cores, Planar cores |

Ferrite Materials



| | | | INDUCTORS & POWER TRANSFORMERS | | | | | EMI/RFI FILTERS & BROADBAND TRANSFORMERS | | | LINEAR FILTERS & SENSORS | | |
|---|--------------------------------|---------------------------------|--------------------------------|---------------|---------------|---------------|---------------|--|----------------|----------------|--------------------------|---------------|---------------|
| MATERIAL | | | L | R | P | F | T | J | W | M | C | E | V |
| Initial Permeability | μ_i | | 750 ±25% | 2,300 ±25% | 2,500 ±25% | 3,000 ±20% | 3,000 ±25% | 5,000 ±20% | 10,000 ±30% | 15,000 ±30% | 900 ±25% | 2,000 ±25% | 2,300 ±25% |
| Maximum Usable Frequency (50% roll-off) | f | MHz | ≤6 | ≤1.8 | ≤1.8 | ≤1.5 | ≤1.5 | ≤0.7 | ≤0.5 | ≤0.12 | ≤8 | ≤3 | ≤1.5 |
| Relative Loss Factor X 10 ⁻⁶ 25°C | | $\frac{\tan \delta}{\mu_{iac}}$ | | | | | | ≤15 100 kHz | ≤7 10 kHz | ≤10 10 kHz | ≤10 300 kHz | ≤3 100 kHz | ≤5 100 kHz |
| Curie Temperature | T _c | °C | >280 | >210 | >210 | >210 | >220 | >145 | >135 | >130 | >200 | >160 | >170 |
| Flux Density @ 1,194 A/m (15 Oe) 25°C | B _m 10 kHz | G mT | 5,200 520 | 4,700 470 | 4,700 470 | 4,700 470 | 5,300 530 | 4,300 430 | 3,900 390 | 4,700 470 | 3,800 380 | 3,600 360 | 4,400 440 |
| Remanence 25°C | B _r | G mT | 1,500 150 | 1,600 160 | 1,600 160 | 1,500 150 | 1,500 150 | 1,000 100 | 800 80 | 2,700 270 | 1,500 150 | 700 70 | 1,500 150 |
| Power Loss (PL) Sine Wave in mW/cm ³ (typical) | 25 kHz 200 mT (2,000 G) | @25°C | | 90 | 180 | 60 | 80 | | | | | | |
| | | @60°C | | 65 | 110 | 55 | 75 | | | | | | |
| | | @100°C | | 60 | 65 | 90 | 70 | | | | | | |
| | | @120°C | | 65 | 110 | 125 | 75 | | | | | | |
| | 100 kHz 100 mT (1,000 G) | @25°C | | 87 | 70 | 70 | 65 | | | | | | |
| | | @60°C | | 64 | 50 | 65 | 57 | | | | | | |
| | | @100°C | | 58 | 65 | 110 | 55 | | | | | | |
| | | @120°C | | 64 | 45 | 150 | 58 | | | | | | |
| | 500 kHz 50 mT (500 G) | @25°C | 290 | | | | | | | | | | |
| | | @60°C | 150 | | | | | | | | | | |
| | | @100°C | 115 | 175 | 300 | | 150 | | | | | | |
| | | @120°C | 130 | | | | | | | | | | |
| Resistivity | ρ | Ω·m | 10 | 5 | 5 | 5 | 5 | 0.5 | 0.1 | 0.5 | 2 | 2 | 1 |
| Density | δ | g/cm ³ | 4.8 | 4.8 | 4.8 | 4.8 | 4.8 | 4.8 | 4.9 | 5.0 | 4.7 | 4.7 | 4.8 |

Ferrite Materials



TYPICAL MECHANICAL PROPERTIES OF FERRITE MATERIALS

| MECHANICAL DATA | | UNITS | THERMAL DATA | | UNITS |
|----------------------|--|---|---------------------------------|-----------------------|---|
| Bulk Density | 4.85 | g/cm ³ | Coefficient of Linear Expansion | 10.5x10 ⁻⁶ | °C ⁻¹ |
| Tensile Strength | 5.0, 7.0x10 ³ | kgf.mm ⁻² , lbs.in ⁻² | Specific Heat (25°) | 800 | J/kgK |
| Compressive Strength | 45, 63x10 ³ | kgf.mm ⁻² , lbs.in ⁻² | Thermal Conductivity (25-85°C) | 3500-4300 | μW.mm ⁻¹ .°C ⁻¹ |
| Youngs Modulus | 12.4x10 ³ , 1.8x10 ⁷ | kgf.mm ⁻² , lbs.in ⁻² | | 35-43 | mW.cm ⁻¹ .°C ⁻¹ |
| Hardness (Knoop) | 650 Typical | | | .0083-.010 | cal.s ⁻¹ .cm ⁻¹ .°C ⁻¹ |
| Resistivity | 10 ² -10 ³ | ohm-cm | | | |



R Material

A medium frequency multi-purpose power transformer, inductor and filter material. Widely available in shapes and toroids. Engineered for lowest losses between 90 - 100°C.

Initial Perm (25°C; ≤ 10 kHz) **2,300 \pm 25%**
 Saturation Flux Density (4,700 G at 15 Oe, 25°C) 470 mT, 11.9 A-T/cm
 Curie Temperature 210°C

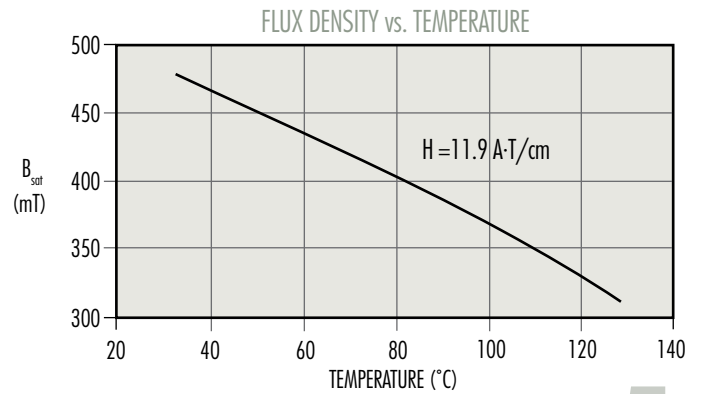
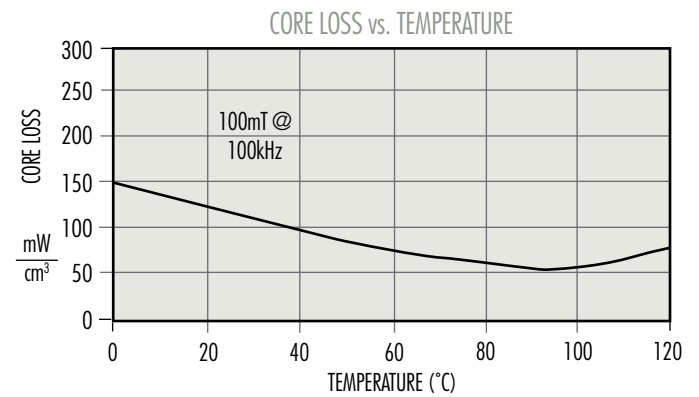
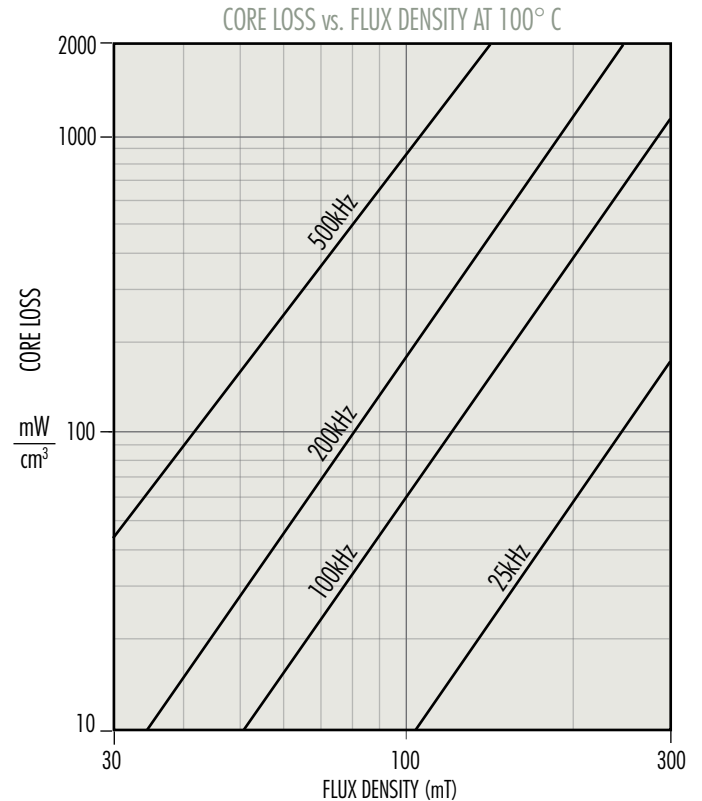
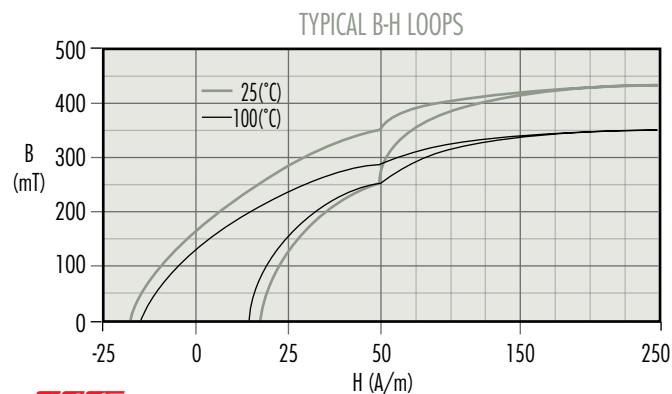
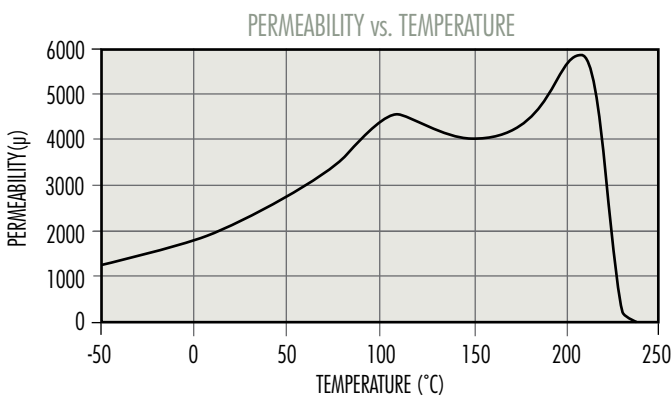
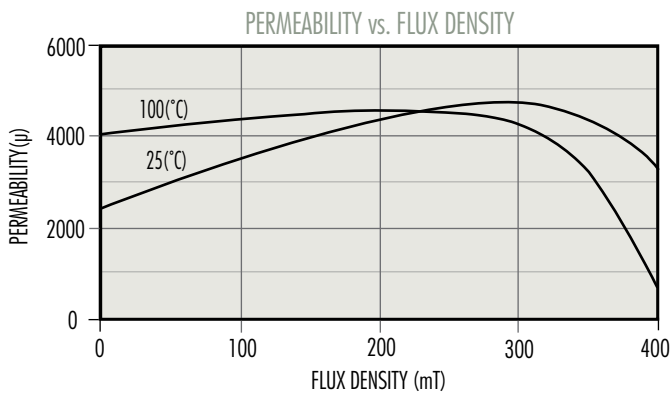
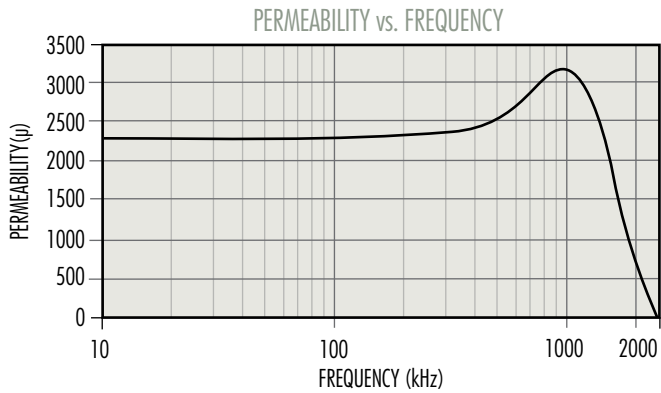

P Material

A low-medium frequency general-purpose power converter material. Engineered for lowest losses between 80 - 100°C. Available in almost all core sizes and shapes.

Initial Perm (25°C; ≤ 10 kHz) **2,500 ± 25%**
 Saturation Flux Density (4,700 G at 15 Oe, 25°C) 470 mT, 11.9 A-T/cm
 Curie Temperature 210°C

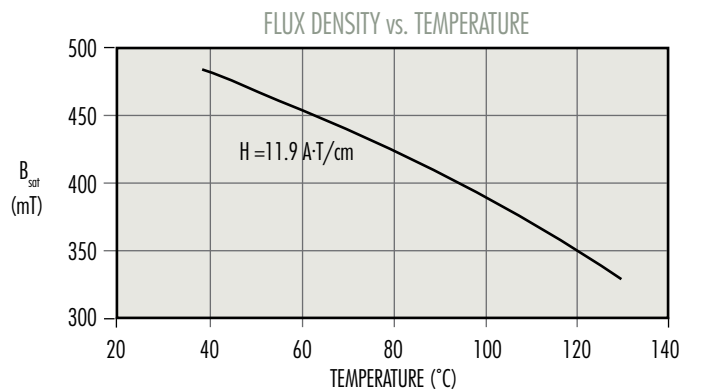
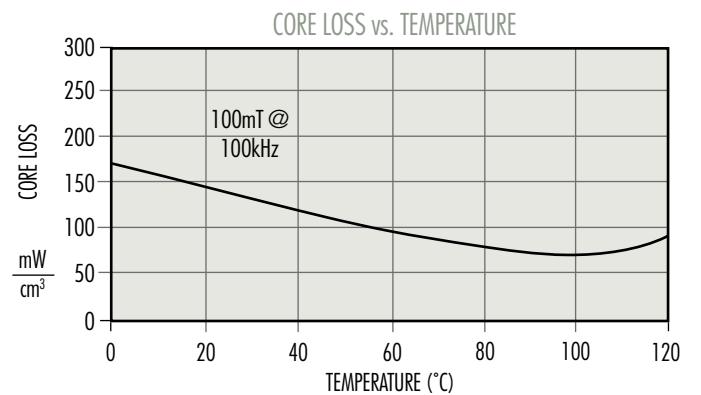
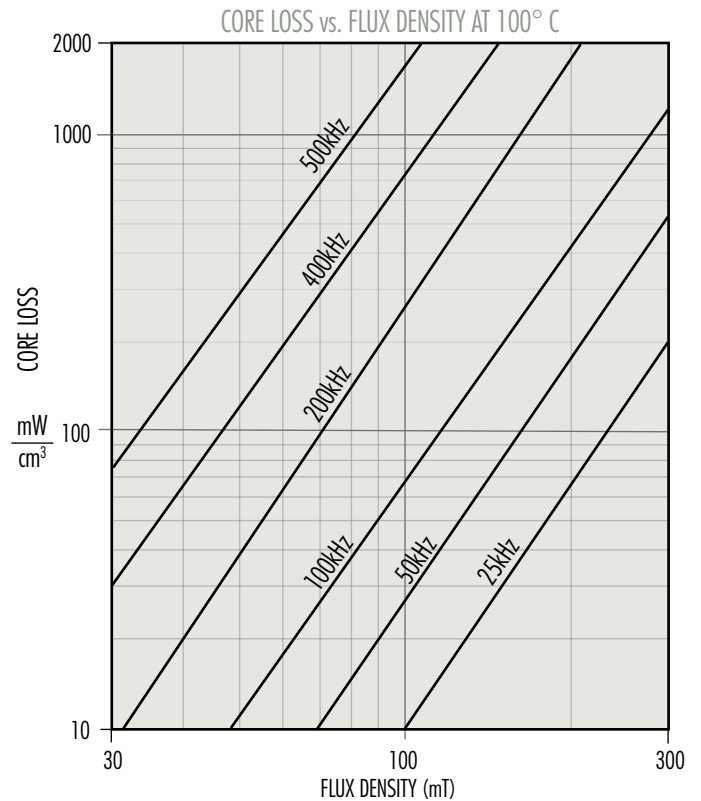
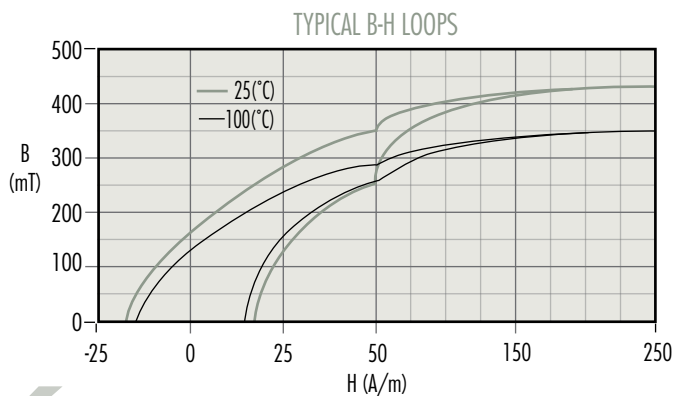
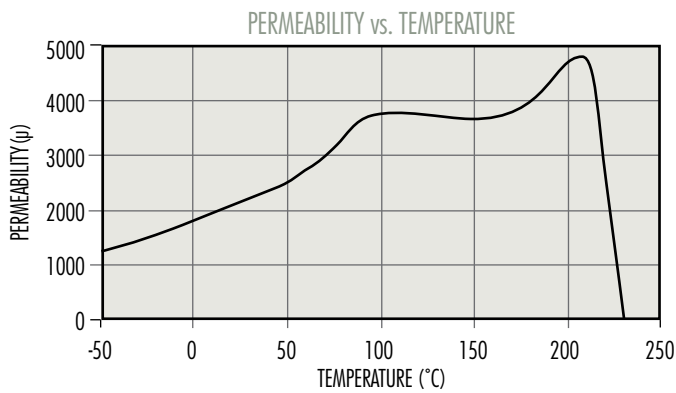
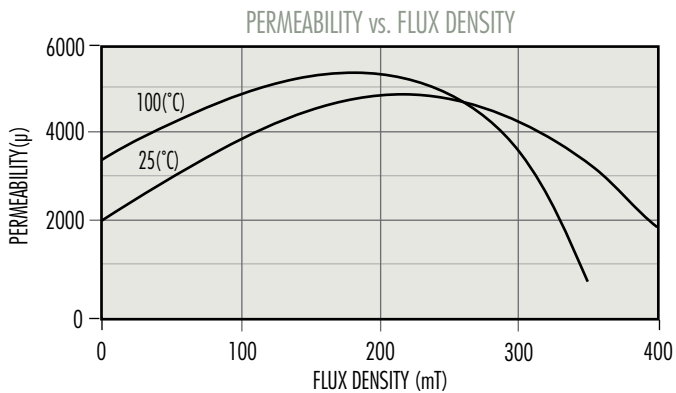
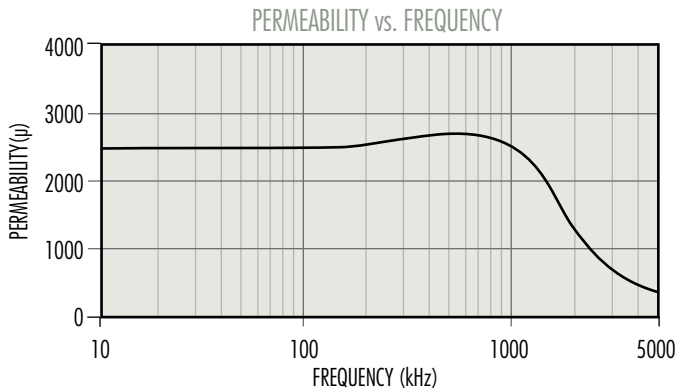

F Material

A medium frequency general-purpose power transformer, inductor and filter material. Slightly higher in perm than P or R Material. Engineered for lowest losses between 50 - 80°C.

Initial Perm (25°C; ≤ 10 kHz) **3,000 ± 20%**
 Saturation Flux Density (4,700 G at 15 Oe, 25°C) 470 mT, 11.9 A-T/cm
 Curie Temperature 210°C

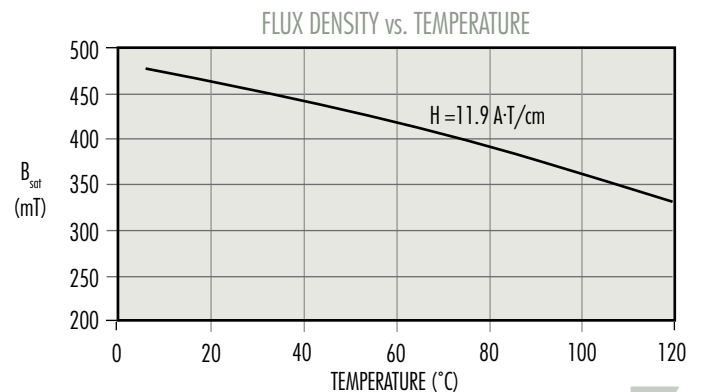
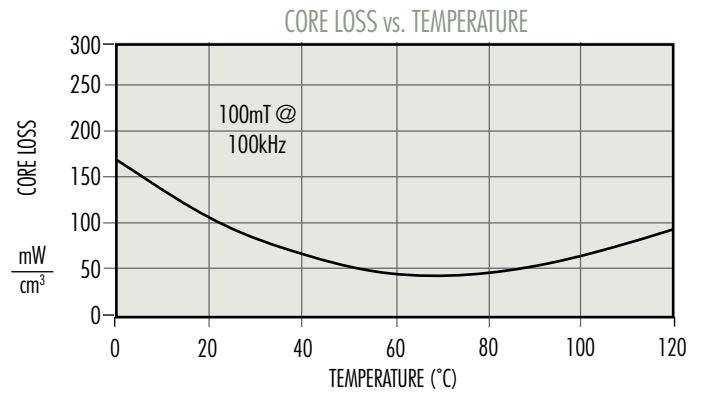
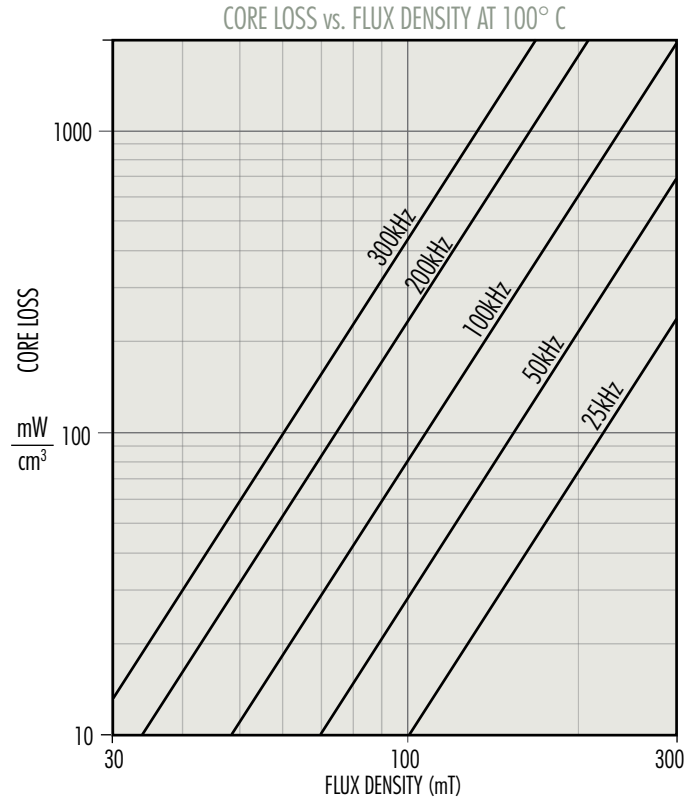
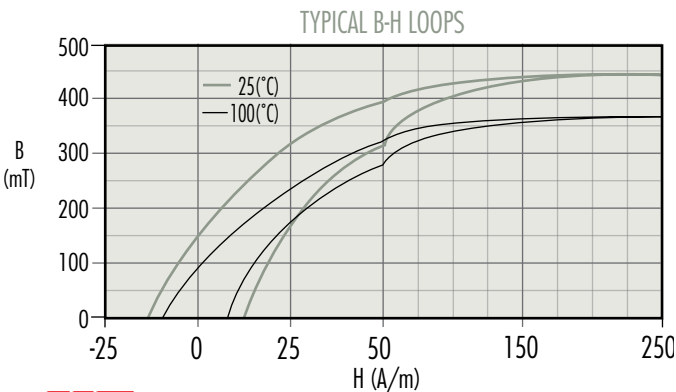
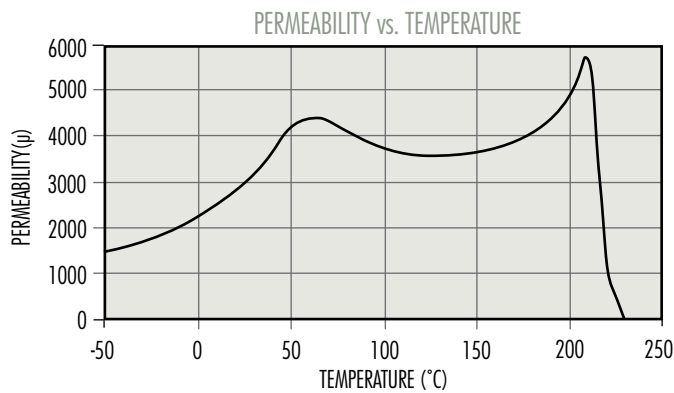
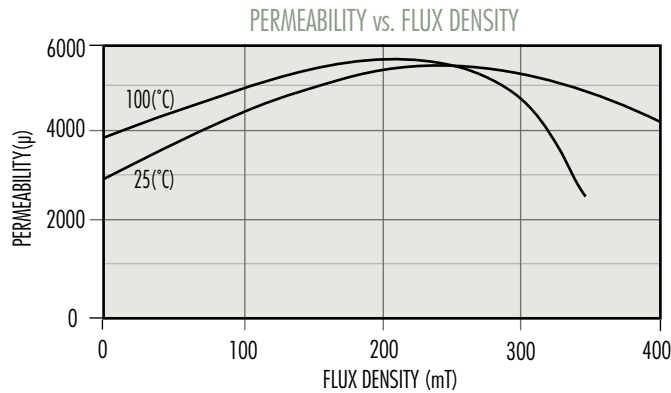
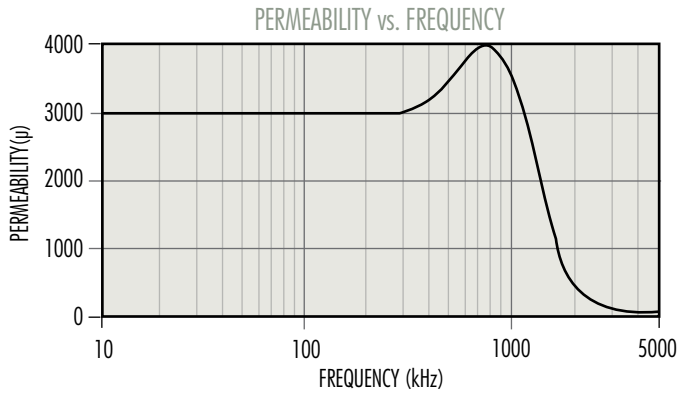

T Material

A power material for transformers and inductors operating from 20 kHz to 750 kHz. T material offers stability in both perm and losses over a wide temperature range.

Initial Perm (25°C; ≤ 10 kHz) **3,000 ± 25%**
 Saturation Flux Density (5,300 G at 15 Oe, 25°C) 530 mT, 11.9 A-T/cm
 Curie Temperature 220°C

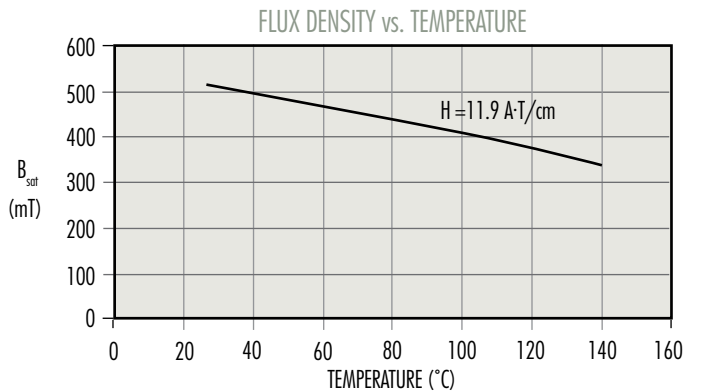
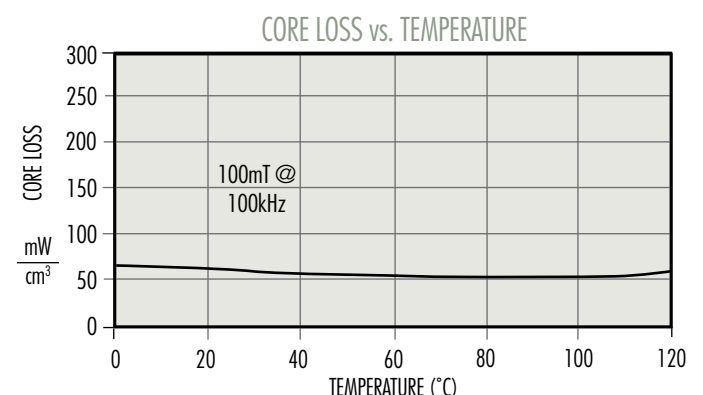
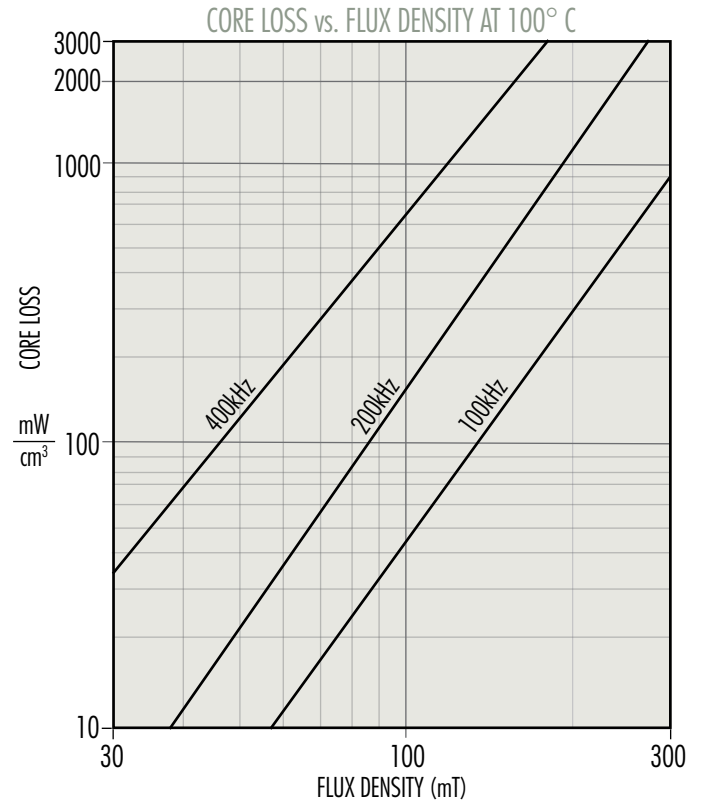
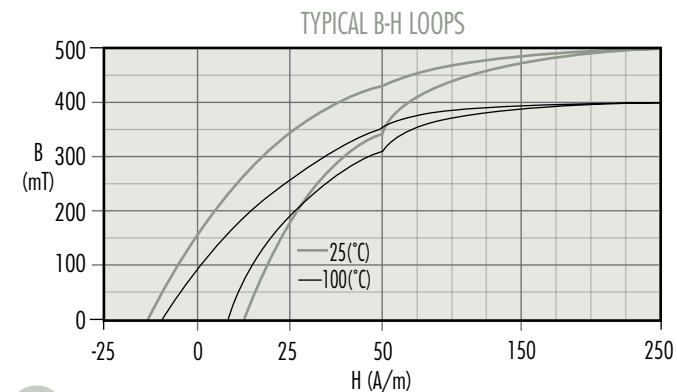
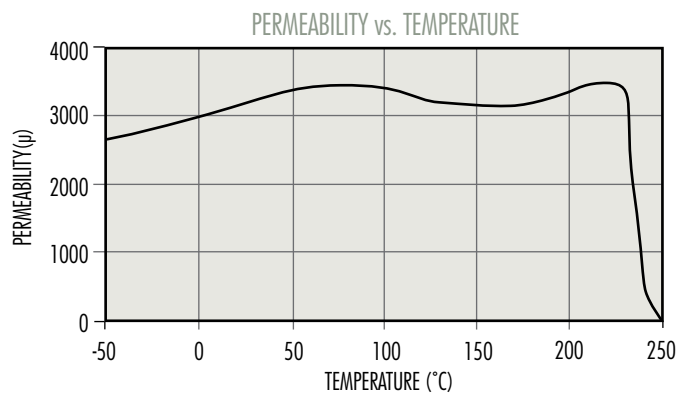
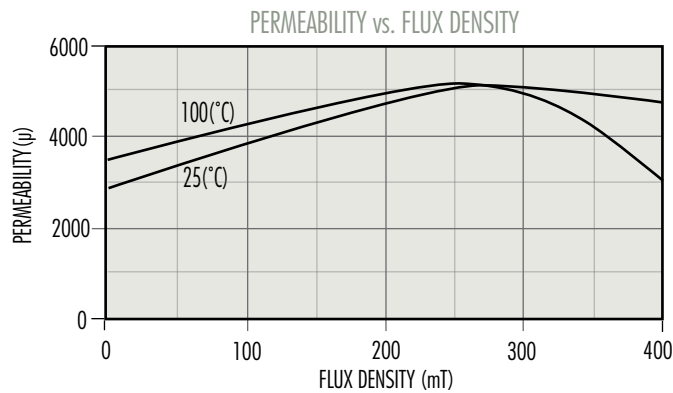
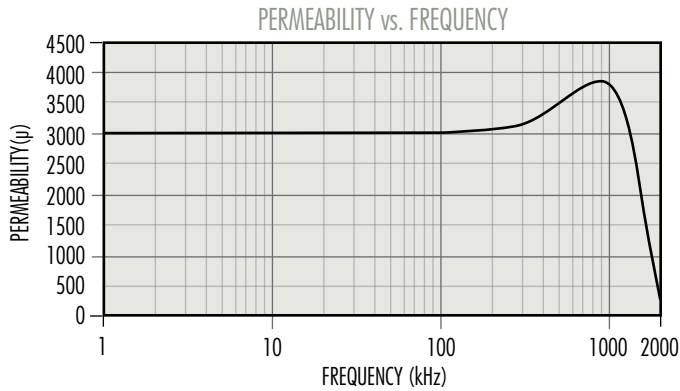

L Material

A high-frequency high-temperature power material.
L material is optimized for transformers and inductors from 500 kHz – 3 MHz. Core losses are minimized between 70 – 100°C.

Initial Perm (25°C; ≤ 10 kHz) $750 \pm 25\%$
Saturation Flux Density (5,200 G at 15 Oe, 25°C) 520 mT, 12 A-T/cm
Curie Temperature 280°C

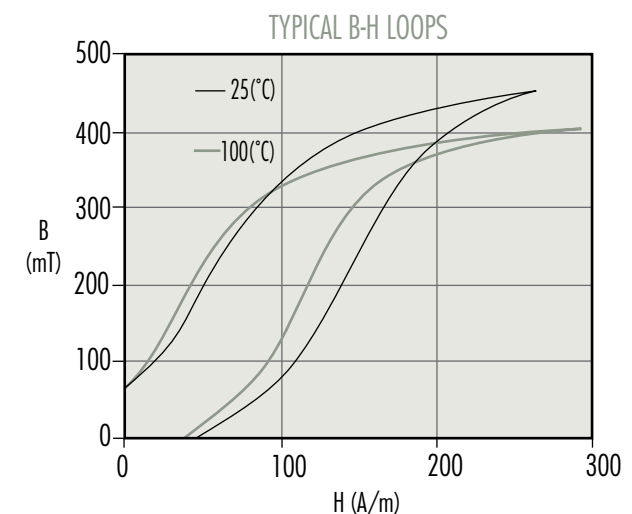
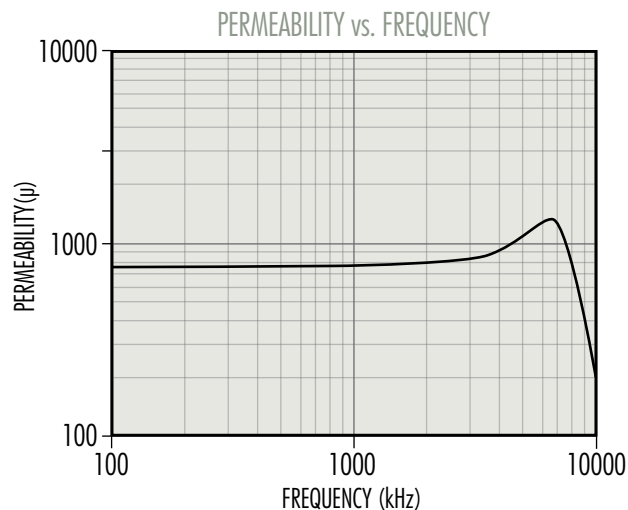
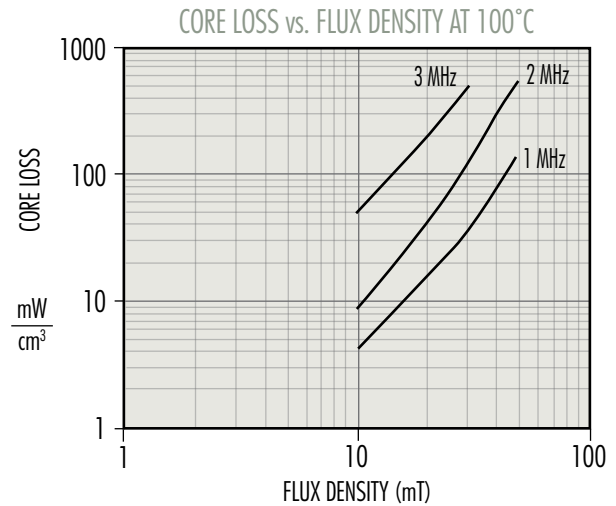
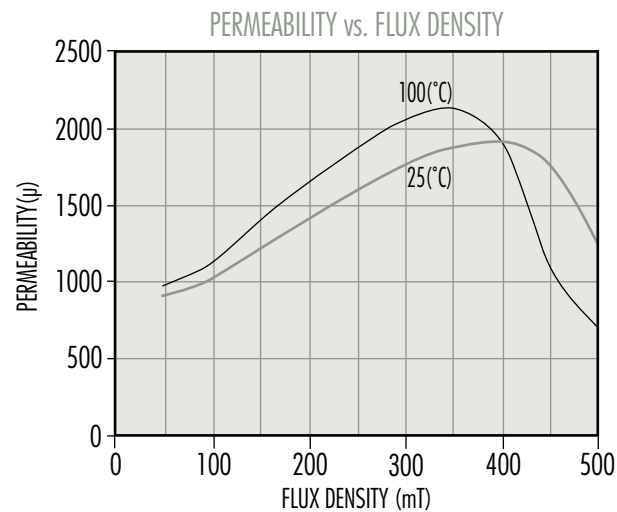
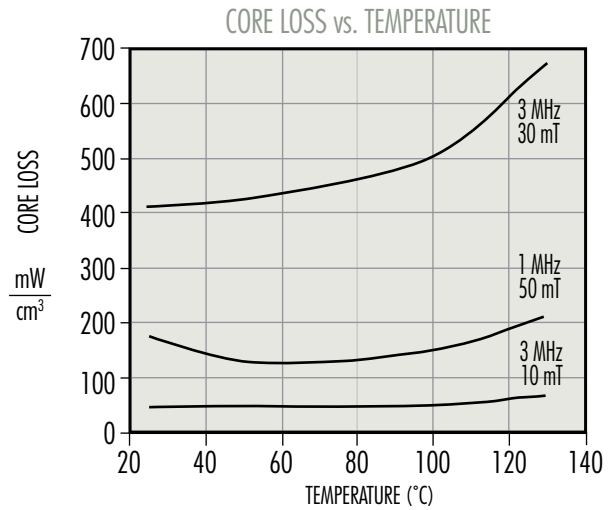
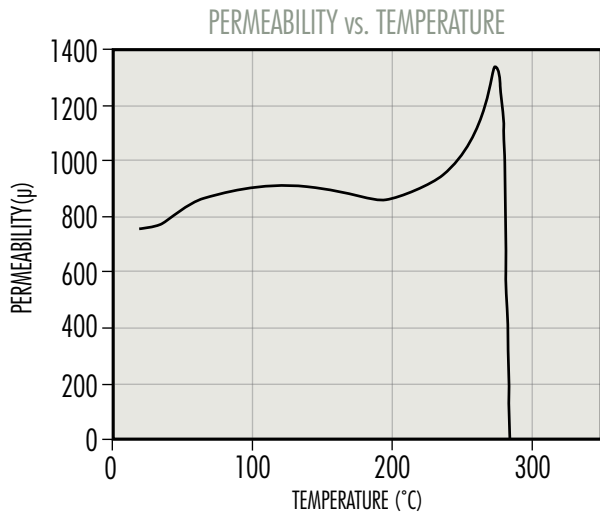

C Material

C Material works well for Telecom Filters, Wideband, Matching and Pulse transformer applications, and High Q inductors.

Initial Perm (25°C; ≤ 10 kHz), Uncoated **900 \pm 25%**
Saturation Flux Density 380 mT, 11.9 A-T/cm (3,800 G at 25°C, 15 Oe)
Curie Temperature 200°C

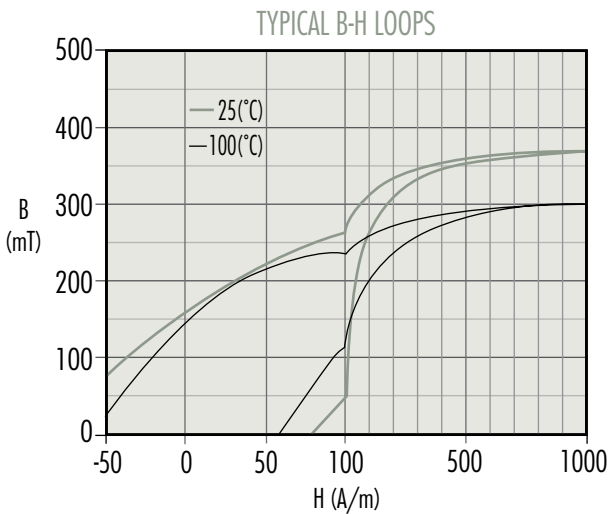
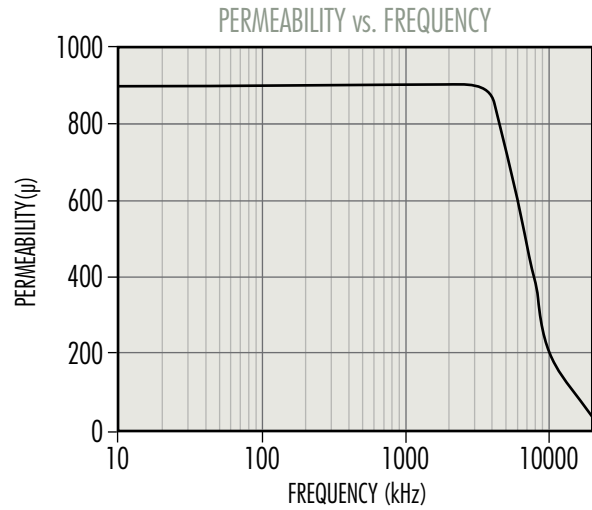
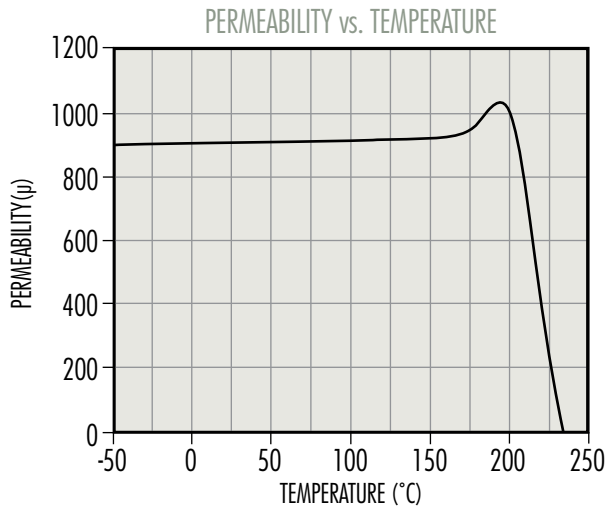

E Material

E Material works well for Telecom Filters, Wideband, Matching and Pulse transformer applications, and High Q inductors.

Initial Perm (25°C; ≤ 10 kHz), Uncoated **2,000 \pm 25%**
 Saturation Flux Density 360 mT, 11.9 A-T/cm (3,600 G at 25°C, 15 Oe)
 Curie Temperature 160°C

PERMEABILITY vs. TEMPERATURE

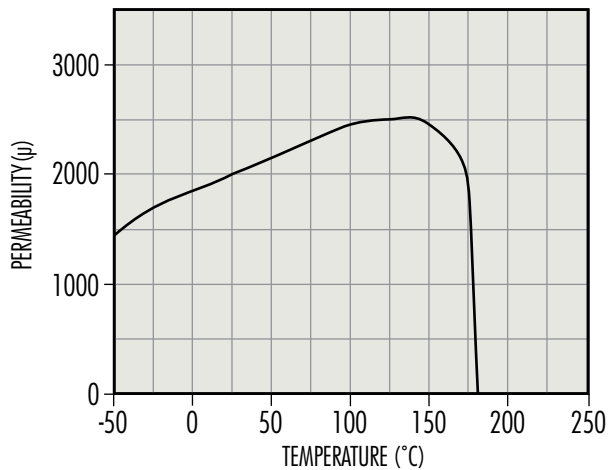

PERMEABILITY vs. FREQUENCY

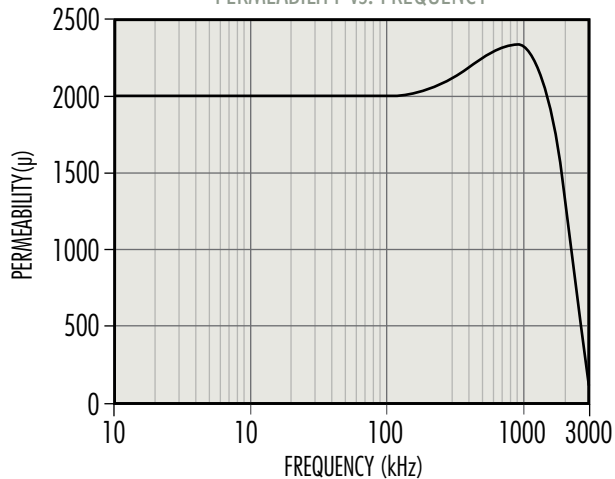

TYPICAL B-H LOOPS

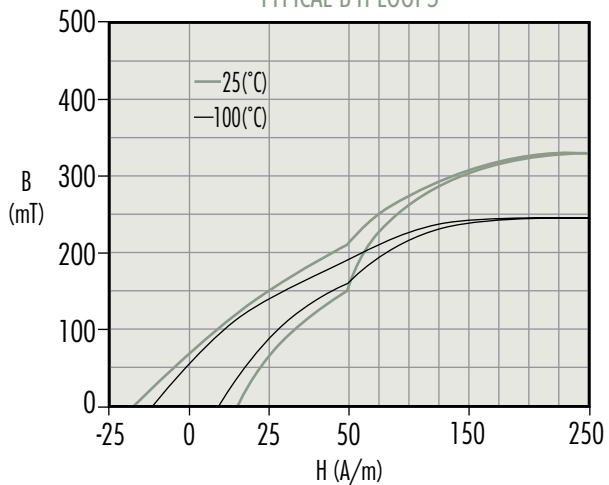

V Material

V Material works well for Telecom Filters, Wideband, Matching and Pulse transformer applications, and High Q inductors.

Initial Perm (25°C; ≤ 10 kHz), Uncoated **2,300 \pm 25%**

Saturation Flux Density 440 mT, 11.9 A·T/cm (4,400 G at 25°C, 15 Oe)

Curie Temperature 170°C

PERMEABILITY vs. TEMPERATURE

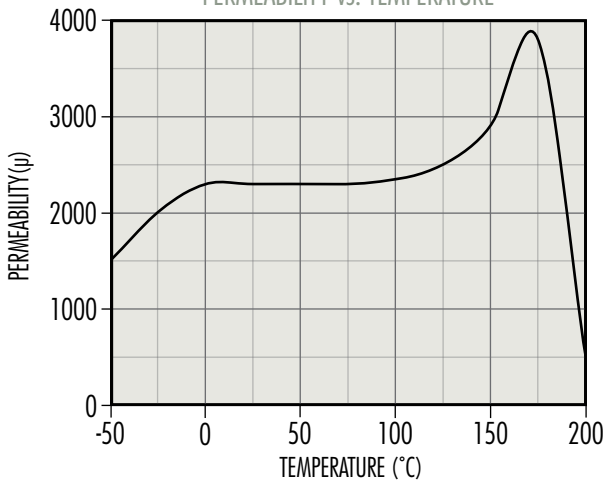

PERMEABILITY vs. FREQUENCY

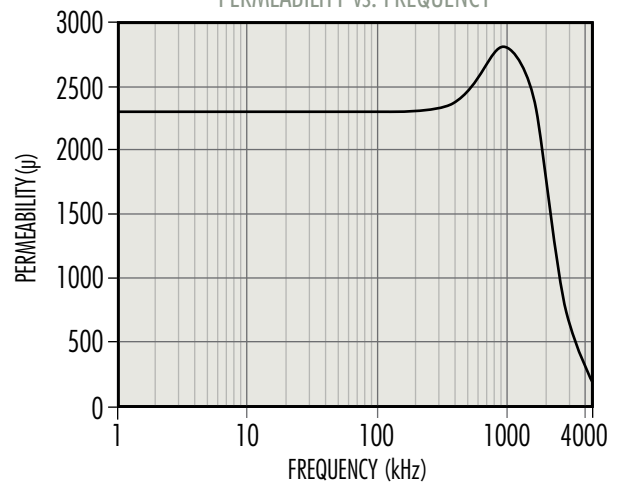

TYPICAL B-H LOOPS

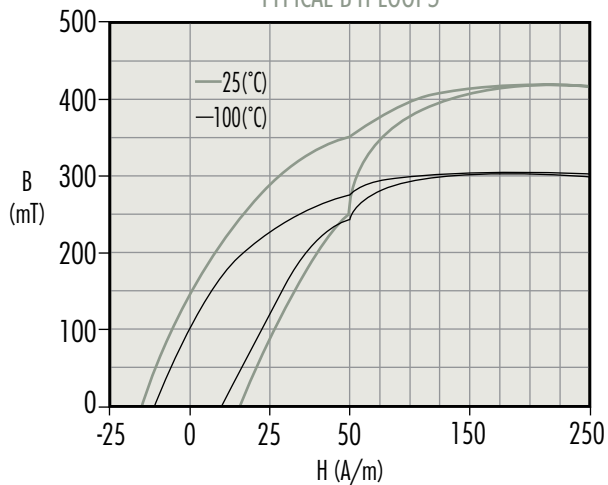

J Material

A medium perm general-purpose material. Well suited both for EMI/RFI filtering and broadband transformers.

Initial Perm (25°C; ≤ 10 kHz) **5,000 ± 20%**
 Saturation Flux Density (4,300 G at 15 Oe, 25°C) 430 mT, 11.9 A-T/cm
 Curie Temperature 145°C

PERMEABILITY vs. TEMPERATURE

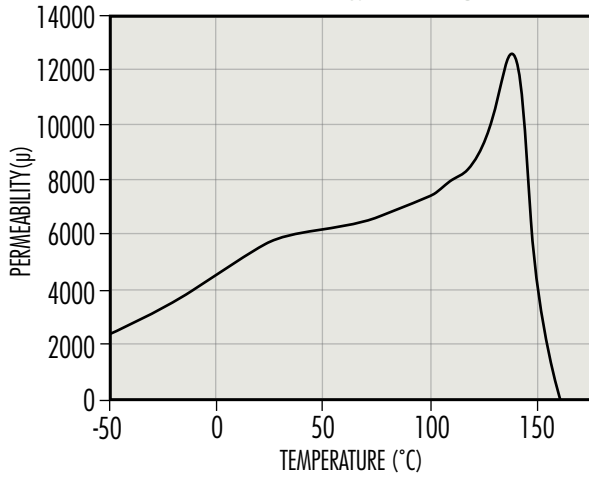

PERMEABILITY vs. FREQUENCY

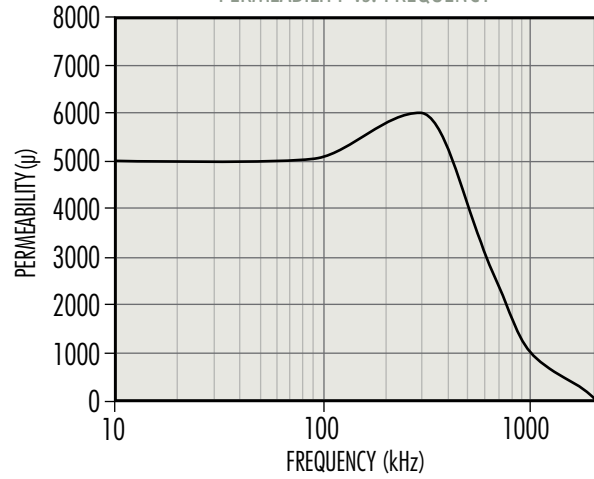

PERMEABILITY vs. DC BIAS

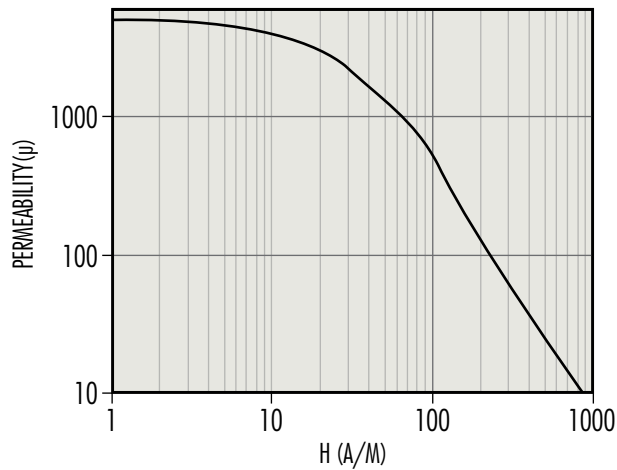

TYPICAL B-H LOOPS

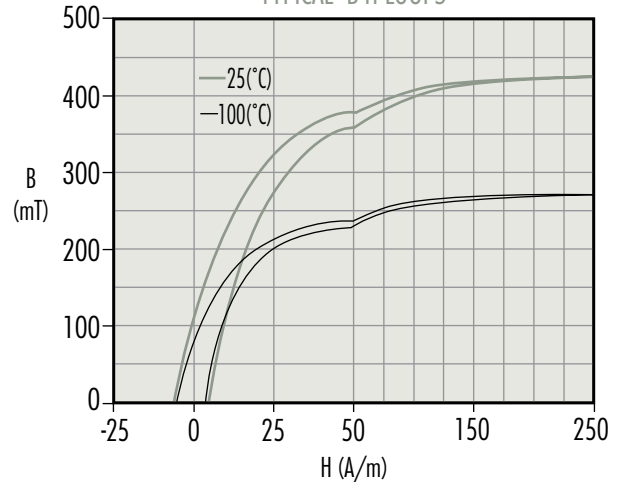

W Material

A high permeability material used for EMI/RFI suppression, common mode chokes, pulse and broadband transformers.

Initial Perm (25°C; ≤ 10 kHz) **10,000 \pm 30%**
 Saturation Flux Density (3,900 G at 15 Oe, 25°C) 390 mT, 11.9 A-T/cm
 Curie Temperature 135°C

PERMEABILITY vs. TEMPERATURE

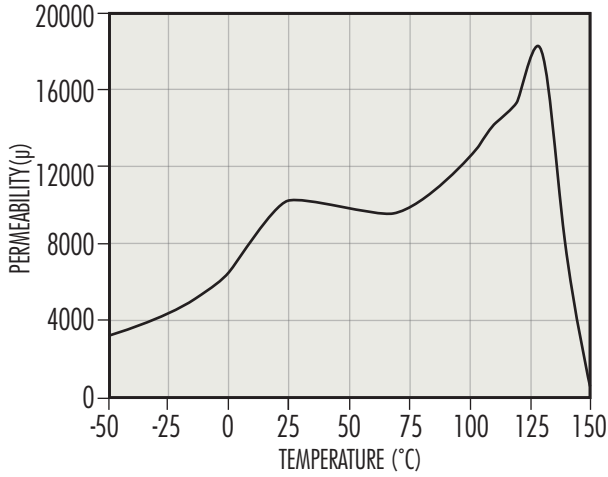

PERMEABILITY vs. FREQUENCY

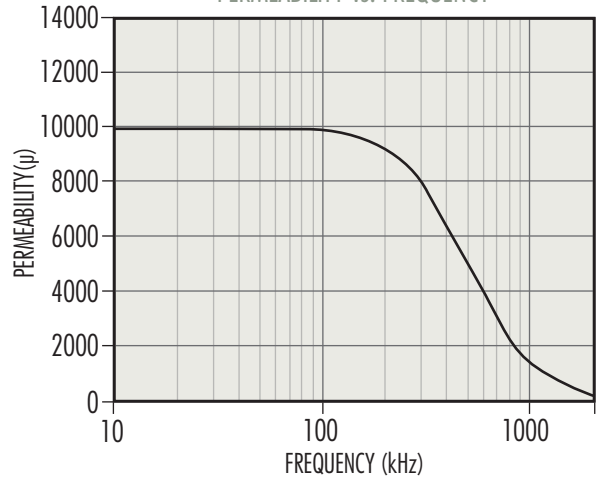

PERMEABILITY vs. DC BIAS

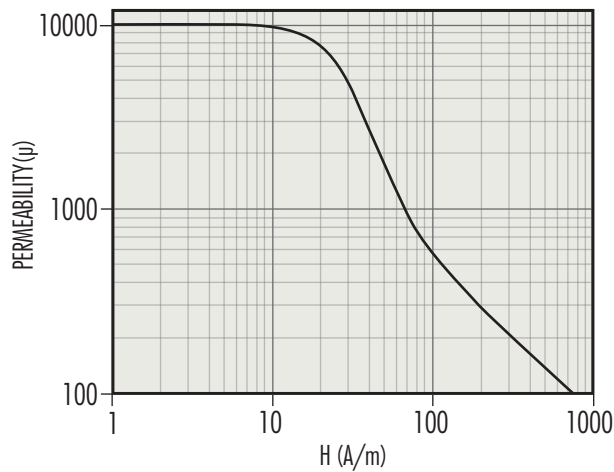

TYPICAL B-H LOOPS

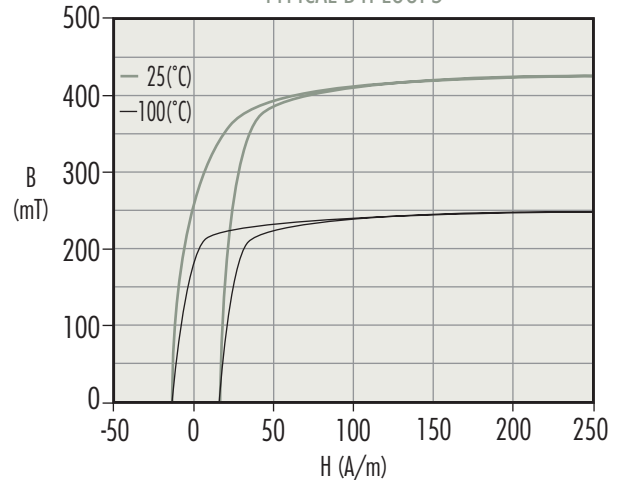

M Material

Highest permeability material used for EMI/RFI suppression, common mode chokes, pulse and broadband transformers.

Initial Perm (25°C; ≤ 10 kHz) **15,000 ± 30%**
 Saturation Flux Density (4,700 G at 15 Oe, 25°C) 470 mT, 11.9 A-T/cm
 Curie Temperature 130°C

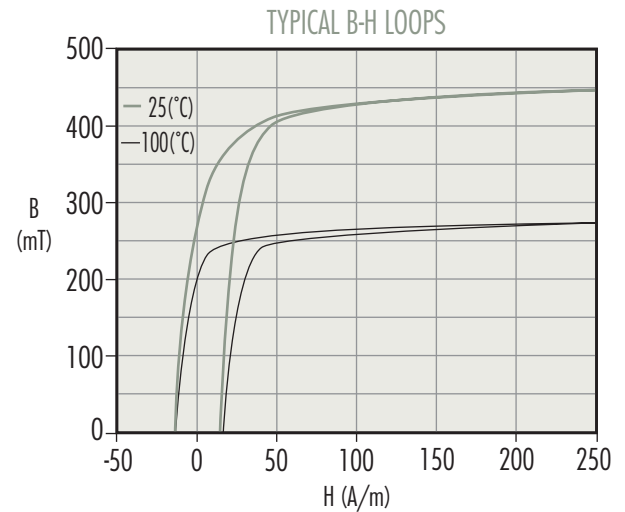
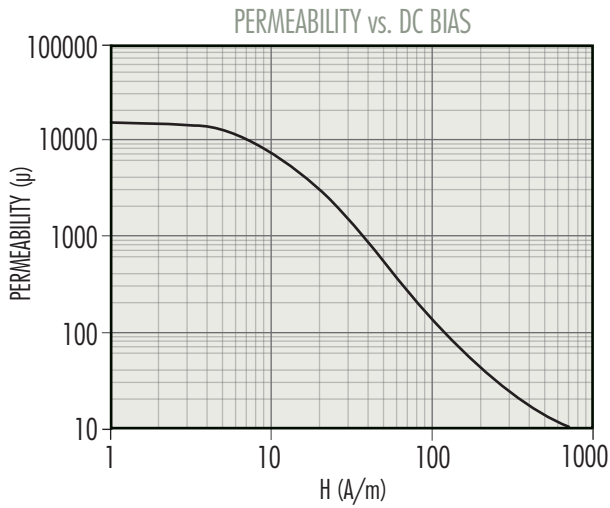
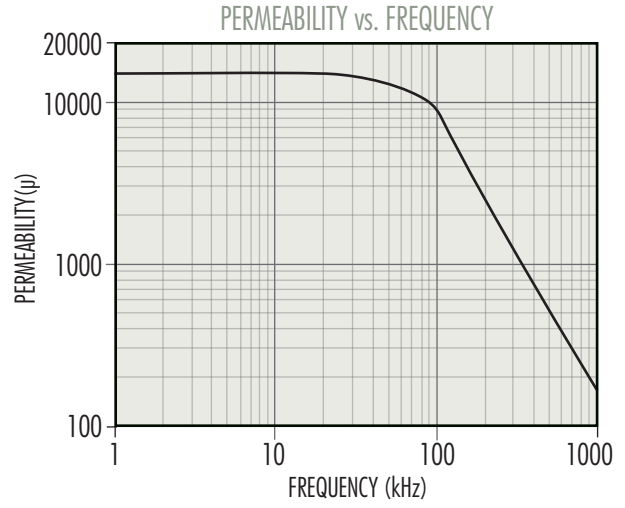
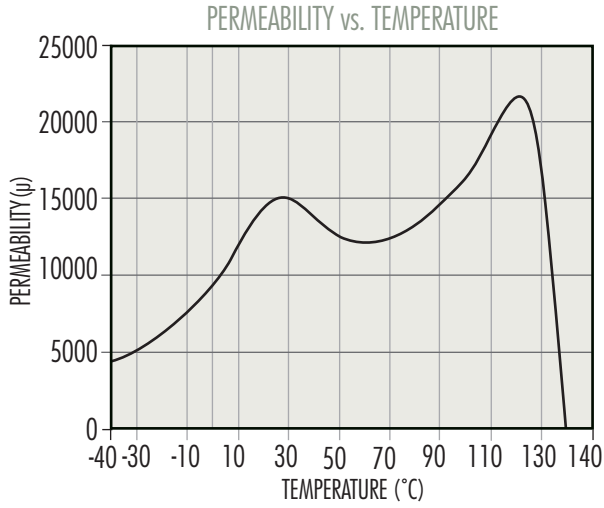

Gapped Cores

How To Order

Part Number



Gap Code

The letter indicates the type of gap and a three-digit number defines the value.

| CODE | MEANING | EXAMPLE |
|----------------|---|---|
| A _ _ _ | A_L (if <1000) | DF42311 A275 (A _L =275) |
| X _ _ _ | A_L if 1000 or greater (add 1000 to code) | OP44721 X250 (A _L =1250) |
| F _ _ _ | A_L if <100, non-integer (divide code by 10) | OR42510 F807 (A _L =80.7) |
| G _ _ _ | Depth of Grind in mils (1000 ^{ths} of an inch) | OF44317 G079 (Gap=0.079") |
| M _ _ _ | Depth of Grind , mm (divide code by 10) | OF43019 M015 (Gap=1.5 mm) |

A_L is inductance factor, mH/1000 Turns, or nH/T².

Either the A_L or the depth of grind (not both) is controlled during production of gapped cores.

See the chart on pages 17-19 for tolerances.

Gap-to-Gap vs Ungapped-to-Gap Core Sets

"Gap-to-gap combination" means the gap is symmetrical. Half of the total gap is removed from each piece.

"Ungapped-to-gap combination" means an asymmetrical gap; the entire gap is taken from one piece, and the other piece is ungapped.

For an E-core gapped to an A_L value when mated with the standard I-core, add "-EI" to the end of the part number.

Gapping for A_L

Inductors are commonly designed with an airgap in the magnetic path where the center legs or center posts of two ferrite pieces meet. This airgap allows the inductance to be controlled to a tight tolerance, and it allows the inductor to support a defined level of DC current without saturating. Inductors are commonly designed with an airgap in the magnetic path where the center legs or center posts of two ferrite pieces meet. This airgap allows the inductance to be controlled to a tight tolerance, and it allows the inductor to support a defined level of DC current without saturating. In most applications, defining the gap with the A_L results in inductors with the least variation.

When specifying and ordering E cores (including EC, EFD, EER, ETD, and Planar E cores) gapped to an A_L, it is important to note which cores are produced in gap-to-gap combination, because two gapped pieces are assembled to achieve the A_L. Alternatively, for E cores provided ungapped-to-gap, an ungapped piece must be used with a gapped piece to achieve the A_L. Pot, RS, DS, RM, PQ, and EP cores are sold as sets whether the combination is gap-to-gap or ungapped-to-gap.

A_L testing and limits are calculated to three significant digits based on the nominal value. For example, A_L=99±3% is interpreted as 96.0 Minimum, 99.0 Nominal, and 102.0 Maximum.

Magnetics tests gapped A_L values with full bobbins, usually 100 turns, or 250 turns for deep gaps. The drive level is low (0.5 mT) and the frequency is set low enough to avoid resonance effects. Measured inductance in an application may vary significantly from the theoretical value due to low turns, low bobbin fill, leakage effects, resonance effects, or elevated drive levels.

It is important for users to verify the correlation between the test of the core and the specific test being applied to the inductor or transformer. Planar E cores, Planar RM, and Planar PQ cores are especially susceptible to correlation discrepancies.

Gapping for Depth of Grind

Even though controlling A_L is usually the way to get the best consistency in finished inductor performance, in some cases the best results are seen when the depth of grind is specified instead. This is generally in cases where the gap dimension is quite large (the A_L is low), because variation in the inductance of the wound device is dominated by variation in the windings, especially if the number of turns is low.

For parts ordered in pieces (E cores), the depth of grind is given for each piece. To make an ungapped-to-gap set, use one piece of each. For example, use OR41808G050 with OR41808EC for an asymmetrical gap of 0.050" ± 0.001. For the same gap, but symmetrical, use two pieces of OR41808G025.

For parts ordered in sets, the depth of grind is given as a total for the set, and may be ungapped-to-gap core pieces or gap-to-gap.

Gapped Cores

Depth of Grind Tolerances

Tolerance Ranges for Pot, RS, DS, RM, PQ, and EP cores

| INCHES | | | | MILLIMETERS | | GAP CONDITION |
|---------------|-------------------|----------------------------|-------------------|-----------------|-----------|--|
| GAP | TOLERANCE < 40 mm | TOLERANCE 40 mm to < 60 mm | TOLERANCE ≥ 60 mm | GAP | TOLERANCE | |
| 0.001"–0.038" | ± 0.0005" | ± 0.00075" | ± 0.001" | 0.1 mm – 0.9 mm | ± 0.03 mm | Ungapped to gap combination |
| 0.039"–0.076" | ± 0.001" | ± 0.0015" | ± 0.002" | 1.0 mm – 1.9 mm | ± 0.04 mm | Ungapped to gap combination (Except if the gap is more than 10% of the minimum bobbin depth for the set*, then gap-to-gap combination.) |
| 0.077"–0.114" | ± 0.002" | ± 0.003" | ± 0.004" | 2.0 mm – 2.9 mm | ± 0.07 mm | Gap to gap combination (Except if the gap is less than 10% of the minimum bobbin depth for the set*, then ungapped-to-gap combination.) |
| 0.115"–0.152" | ± 0.002" | ± 0.003" | ± 0.004" | 3.0 mm – 3.8 mm | ± 0.07 mm | Gap to gap combination |
| 0.153"–0.228" | ± 0.004" | ± 0.006" | ± 0.008" | 3.9 mm – 5.0 mm | ± 0.12 mm | Gap to gap combination |

*The bobbin depth for the set is the 2D dimension or 2 times the D dimension

Tolerance Ranges for E, EC, ER, EER, EFD, ETD and Planar E cores

| INCHES | | | | MILLIMETERS | |
|---------------|-------------------|----------------------------|-------------------|-----------------|-----------|
| GAP | TOLERANCE < 40 mm | TOLERANCE 40 mm to < 60 mm | TOLERANCE ≥ 60 mm | GAP | TOLERANCE |
| 0.001"–0.038" | ± 0.0005" | ± 0.00075" | ± 0.001" | 0.1 mm – 0.9 mm | ± 0.03 mm |
| 0.039"–0.076" | ± 0.001" | ± 0.0015" | ± 0.002" | 1.0 mm – 1.9 mm | ± 0.04 mm |
| 0.077"–0.152" | ± 0.002" | ± 0.003" | ± 0.004" | 2.0 mm – 3.8 mm | ± 0.07 mm |
| 0.153"–0.228" | ± 0.004" | ± 0.006" | ± 0.008" | 3.9 mm – 5.0 mm | ± 0.12 mm |

Gapped Cores

A_L Value Tolerances

| SIZE | GAP TO GAP ± 3% | UNGAPPED TO GAP COMBINATION | | | |
|-------------------------------|-----------------|-----------------------------|-------|-------|-------|
| | | ±3% | ±5% | ±7% | ±10% |
| E CORES* PAGES 28 - 31 | | | | | |
| 41203 | 16-27 | 28-55 | ≤86 | ≤117 | ≤160 |
| 41205 | 28-47 | 48-107 | ≤170 | ≤229 | ≤316 |
| 41707 | 22-37 | 38-89 | ≤140 | ≤190 | ≤259 |
| 41808 | 27-42 | 43-121 | ≤192 | ≤258 | ≤355 |
| 41810 | 44-74 | 75-235 | ≤376 | ≤512 | ≤704 |
| 42510 | 37-61 | 62-200 | ≤318 | ≤432 | ≤595 |
| 42515 | 28-43 | 44-210 | ≤333 | ≤452 | ≤616 |
| 42520 | 107-190 | 191-397 | ≤643 | ≤874 | ≤1202 |
| 42530 | 45-72 | 73-409 | ≤655 | ≤891 | ≤1225 |
| 43007 | 42-67 | 68-307 | ≤491 | ≤668 | ≤919 |
| 43009 | 55-91 | 92-222 | ≤353 | ≤475 | ≤653 |
| 43515 | 54-87 | 88-429 | ≤687 | ≤934 | ≤1284 |
| 43520 | 65-111 | 112-461 | ≤738 | ≤1003 | ≤1380 |
| 44011 | 59-95 | 96-642 | ≤1029 | ≤1400 | ≤1940 |
| 44016 | 52-83 | 84-545 | ≤872 | ≤1185 | ≤1629 |
| 44020 | 78-126 | 127-916 | ≤1480 | ≤1999 | |
| 44022 | 94-156 | 157-1187 | ≤1903 | ≤1999 | |
| 44317 | 81-136 | 137-762 | ≤1222 | ≤1676 | ≤1999 |
| 44721 | 107-180 | 181-1188 | ≤1920 | ≤1999 | |
| 45528 | 113-186 | 187-500 | ≤1999 | | |
| 45530 | 150-360 | 361-600 | ≤1999 | | |
| 45724 | 129-218 | 219-450 | ≤1999 | | |
| 46016 | 102-129 | 130-1231 | ≤1999 | | |
| 46527 | 142-235 | 236-650 | ≤1999 | | |
| 47133 | 150-285 | 286-950 | ≤1999 | | |
| 47228 | 120-199 | 200-1823 | ≤1999 | | |
| 48020 | 99-158 | 159-1922 | ≤1999 | | |
| 49928 | 150-285 | 286-975 | ≤1999 | | |
| EC CORES PAGES 42 - 43 | | | | | |
| 43517 | 49-79 | 80-438 | ≤702 | ≤954 | ≤1312 |
| 44119 | 61-98 | 99-627 | ≤1004 | ≤1365 | ≤1891 |
| 45224 | 76-123 | 124-911 | ≤1471 | ≤1999 | |
| 47035 | 83-135 | 136-1403 | ≤1999 | | |

*These tolerances also apply to E-I combination.

| SIZE | GAP TO GAP ±3% | UNGAPPED TO GAP COMBINATION | | | |
|--|----------------|-----------------------------|-------|-------|-------|
| | | ±3% | ±5% | ±7% | ±10% |
| PLANAR E CORES* PAGES 32 - 35 | | | | | |
| 41425 | 19-35 | 36-76 | ≤122 | ≤166 | ≤228 |
| 41434 | 17-31 | 32-77 | ≤123 | ≤167 | ≤230 |
| 41805 | 18-32 | 33-205 | ≤329 | ≤448 | ≤617 |
| 42107 | 35-66 | 67-188 | ≤304 | ≤414 | ≤569 |
| 42216 | 78-141 | 142-405 | ≤656 | ≤892 | ≤1239 |
| 43208 | 118-216 | 217-643 | ≤1040 | ≤1427 | ≤1964 |
| 43618 | 119-222 | 223-673 | ≤1088 | ≤1491 | ≤1999 |
| 43808 | 173-315 | 316-956 | ≤1547 | ≤1999 | |
| 44008 | 106-189 | 190-507 | ≤821 | ≤1116 | ≤1548 |
| 44308 | 201-367 | 368-1130 | ≤1828 | ≤1999 | |
| 44310 | 169-305 | 306-1130 | ≤1828 | ≤1999 | |
| 45810 | 266-481 | 482-1496 | ≤1999 | | |
| 46410 | 379-701 | 702-1999 | | | |
| 49938 | 336-594 | 595-1999 | | | |
| ER CORES* PAGES 36 - 37 | | | | | |
| 40906 | 15-65 | 66-70 | ≤110 | ≤150 | ≤200 |
| 41126 | 40-74 | 75-100 | ≤140 | ≤190 | ≤275 |
| 41426 | 45-84 | 85-130 | ≤190 | ≤250 | ≤380 |
| 41826 | 50-84 | 85-200 | ≤325 | ≤445 | ≤650 |
| 42313 | 55-90 | 91-200 | ≤525 | ≤710 | ≤900 |
| 43021 | 80-169 | 170-710 | ≤1050 | ≤1460 | ≤1975 |
| EER/ETD CORES PAGES 44 - 45/48 - 49 | | | | | |
| 43434 | 55-88 | 89-500 | ≤806 | ≤1095 | ≤1507 |
| 43521 | 54-86 | 87-566 | ≤913 | ≤1241 | ≤1707 |
| 43939 | 95-156 | 157-641 | ≤1028 | ≤1398 | ≤1935 |
| 44216 | 71-117 | 118-876 | ≤1415 | ≤1925 | ≤1999 |
| 44444 | 73-117 | 118-881 | ≤1423 | ≤1935 | ≤1999 |
| 44949 | 81-130 | 131-1075 | ≤1736 | ≤1999 | |
| 45959 | 51-118 | 119-1822 | ≤1999 | | |
| EFD CORES PAGES 46 - 47 | | | | | |
| 41212 | 18-29 | 30-90 | ≤130 | ≤170 | ≤230 |
| 41515 | 19-30 | 31-81 | ≤127 | ≤172 | ≤236 |
| 42019 | 29-45 | 46-220 | ≤350 | ≤430 | ≤575 |
| 42523 | 41-66 | 67-296 | ≤475 | ≤646 | ≤888 |
| 43030 | 50-90 | 91-450 | ≤790 | ≤975 | ≤1125 |

Gapped Cores

A_L Value Tolerances

| SIZE | GAP TO GAP ± 3% | UNGAPPED TO GAP COMBINATION | | | |
|------------------------------|--------------------|-----------------------------|-------|-------|-------|
| | | ±3% | ±5% | ±7% | ±10% |
| EP CORES | | PAGES 52 - 53 | | | |
| 40707 | 25-50 | 51-75 | ≤125 | | ≤160 |
| 41010 | 25-55 | 56-75 | ≤125 | | ≤160 |
| 41313 | 25-75 | 76-110 | ≤175 | ≤275 | ≤315 |
| 41717 | 25-100 | 101-175 | ≤275 | ≤400 | ≤630 |
| 42120 | 25-180 | 181-450 | ≤630 | ≤850 | ≤1250 |
| POT CORES | | PAGES 54 - 55 | | | |
| 40704 | 25-35 | 36-62 | ≤95 | ≤125 | ≤175 |
| 40905 | 25-48 | 49-87 | ≤135 | ≤180 | ≤240 |
| 41107 | 25-75 | 76-135 | ≤220 | ≤285 | ≤399 |
| 41408 | 71-113 | 114-210 | ≤307 | ≤417 | ≤574 |
| 41811 | 96-174 | 175-326 | ≤523 | ≤712 | ≤988 |
| 41814 | 65-135 | 136-340 | ≤510 | ≤700 | ≤980 |
| 42213 | 113-204 | 205-482 | ≤779 | ≤1060 | ≤1459 |
| 42616 | 139-249 | 250-695 | ≤1125 | ≤1543 | ≤1999 |
| 43019 | 170-304 | 305-1015 | ≤1642 | ≤1999 | |
| 43622 | 222-399 | 400-1494 | ≤1999 | | |
| 44229 | 169-389 | 390-1965 | ≤1999 | | |
| RS (ROUND-SLAB) CORES | | PAGES 56 - 57 | | | |
| 41408 | | 25-177 | ≤283 | ≤385 | ≤530 |
| 41811 | 25-39 | 40-270 | ≤400 | ≤525 | ≤800 |
| 42311 | 25-39 | 40-347 | ≤708 | ≤963 | ≤1325 |
| 42318 | 25-39 | 40-452 | ≤731 | ≤994 | ≤1378 |
| 42616 | 25-39 | 40-622 | ≤998 | ≤1369 | ≤1884 |
| 43019 | 25-62 | 63-918 | ≤1485 | ≤1999 | |
| 43622 | 40-62 | 63-1286 | ≤1999 | | |
| 44229 | 40-62 | 63-1732 | ≤1999 | | |

| SIZE | GAP TO GAP ± 3% | UNGAPPED TO GAP COMBINATION | | | |
|-------------------------------|--------------------|-----------------------------|-------|-------|-------|
| | | ±3% | ±5% | ±7% | ±10% |
| DS (DOUBLE SLAB) CORES | | PAGES 56 - 57 | | | |
| 42311 | 109-195 | 196-386 | ≤625 | ≤850 | ≤1170 |
| 42318 | 78-135 | 136-441 | ≤706 | ≤961 | ≤1332 |
| 42616 | 117-205 | 206-580 | ≤930 | ≤1276 | ≤1756 |
| 43019 | 149-264 | 265-873 | ≤1412 | ≤1922 | ≤1999 |
| 43622 | 170-300 | 301-1111 | ≤1797 | ≤1999 | |
| 44229 | 179-315 | 316-1543 | ≤1999 | | |
| PQ CORES | | PAGES 58 - 59 | | | |
| 42016 | 60-184 | 185-467 | ≤755 | ≤1027 | ≤1425 |
| 42020 | 50-139 | 140-467 | ≤754 | ≤1026 | ≤1422 |
| 42610 | 200-396 | 397-777 | ≤1258 | ≤1728 | ≤1999 |
| 42614 | 110-334 | 335-645 | ≤1044 | ≤1421 | ≤1972 |
| 42620 | 95-296 | 297-888 | ≤1436 | ≤1955 | ≤1999 |
| 42625 | 77-234 | 235-880 | ≤1423 | ≤1936 | ≤1999 |
| 43214 | 127-416 | 417-548 | ≤885 | ≤1207 | ≤1661 |
| 43220 | 128-409 | 410-486 | ≤1369 | ≤1878 | ≤1999 |
| 43230 | 84-241 | 242-808 | ≤1305 | ≤1775 | ≤1999 |
| 43535 | 89-255 | 256-980 | ≤1575 | ≤1999 | |
| 44040 | 83-230 | 231-1006 | ≤1625 | ≤1999 | |
| 45050 | 128-210 | 210-1999 | | | |
| RM CORES | | PAGES 60 - 61 | | | |
| 41110 | 25-50 | 51-55 | ≤75 | ≤170 | ≤250 |
| 41510 | 56-98 | 99-162 | ≤258 | ≤352 | ≤484 |
| 41812 | 69-120 | 121-238 | ≤381 | ≤519 | ≤714 |
| 41912 | 69-120 | 121-238 | ≤381 | ≤519 | ≤714 |
| 42316 | 84-150 | 151-395 | ≤633 | ≤862 | ≤1195 |
| 42819 | 126-200 | 201-625 | ≤1002 | ≤1374 | ≤1892 |
| 43723 | 145-250 | 251-977 | ≤1580 | ≤1999 | |

Chart shows type of combination and the guaranteed tolerance for corresponding A_L ranges. Ranges indicated are the tolerances for standard gaps. For ± 5%, ± 7%, and ± 10%, the maximum A_L for each is shown. Standard cores are manufactured to the smallest allowed tolerances. EE and EI tolerances are identical.

Toroids

2.54 mm – 12.7 mm

Ferrite toroids offer high magnetic efficiency as there is no air gap, and the cross sectional area is uniform. Available in many sizes (O.D. from 2.54 mm to 140 mm) and materials (permeabilities ranging from 750 to 15,000), this section lists common sizes.

Typical applications for high permeability toroids (J, W, and M materials) include common mode chokes, broadband transformers, pulse transformers and current transformers. L, R, P, F and T material toroids are excellent choices for high frequency transformers.

| SIZE (mm) | ORDERING CODE | Y | Z | NOMINAL A_L (mH/1000T) | | | | | | | | | |
|--------------------|------------------|---|---|--------------------------|-------------|-------------|-------------|-------------|-------------|-------------|-------------|-------------|-------|
| | | | | L \pm 25% | R \pm 25% | P \pm 25% | F \pm 20% | T \pm 25% | J \pm 20% | W \pm 30% | M \pm 30% | C \pm 25% | |
| 2.54 x 1.27 x 1.27 | 0_40200TC | ✓ | | | 400 | 454 | 525 | | | 875 | 1,750 | | 158 |
| 3.46 x 1.78 x 1.27 | 0_40301TC | ✓ | | | 380 | 410 | 495 | | | 825 | 1,650 | | 149 |
| 3.94 x 2.24 x 1.27 | 0_40502TC | ✓ | | | 340 | 368 | 440 | | | 735 | 1,470 | 2,152 | 129 |
| 3.94 x 2.24 x 2.54 | 0_40503TC | ✓ | | | 670 | 716 | 885 | | | 1,475 | 2,950 | | 258 |
| 4.83 x 2.29 x 1.27 | 0_40401TC | ✓ | | | 440 | 474 | 570 | | | 950 | 1,900 | | 170 |
| 4.83 x 2.29 x 2.54 | 0_40402TC | ✓ | | | 870 | 948 | 1,140 | | | 1,900 | 3,800 | | 341 |
| 5.84 x 3.05 x 1.52 | 0_40601TC | ✓ | | 178 | 450 | 488 | 585 | 592 | | 980 | 1,960 | 2,963 | 177 |
| 5.84 x 3.05 x 3.18 | 0_40603TC | ✓ | | 372 | 940 | 1,020 | 1,225 | | | 2,040 | 4,080 | 6,199 | 372 |
| 7.62 x 3.18 x 4.78 | 0_40705TC | ✓ | | 751 | 1,920 | 2,088 | 2,505 | | | 4,175 | 8,350 | 12,535 | 751 |
| 9.53 x 5.59 x 7.11 | 0_40907TC | ✓ | ✓ | 683 | 1,730 | 1,884 | 2,260 | | | 3,765 | 7,530 | | 683 |
| 9.53 x 4.75 x 3.18 | 0_41003TC | ✓ | ✓ | 399 | 1,000 | 1,095 | 1,314 | 1,330 | | 2,196 | 4,392 | 6,644 | 399 |
| 9.53 x 4.75 x 4.78 | 0_41005TC | ✓ | ✓ | 599 | 1,510 | 1,650 | 1,980 | | | 3,308 | 6,616 | 9,988 | 599 |
| 12.7 x 5.16 x 6.35 | 0_41206TC | ✓ | ✓ | 1,029 | 2,600 | 2,820 | 3,384 | | | 5,640 | 11,280 | 17,163 | 1,029 |
| 12.7 x 8.14 x 3.18 | 0_41303TC | | ✓ | 255 | 680 | 745 | 894 | | | 1,488 | 2,976 | | 254 |
| 12.7 x 8.14 x 3.89 | 0_41304TC | | ✓ | 311 | 850 | 931 | 1,116 | | | 1,860 | 3,720 | | 311 |
| 12.7 x 8.14 x 5.08 | 0_41305TC | | ✓ | 407 | 1,090 | 1,190 | 1,430 | | | 2,380 | 4,760 | | 406 |
| 12.7 x 8.14 x 6.35 | 0_41306TC | | ✓ | 508 | 1,360 | 1,485 | 1,782 | 1,700 | | 2,968 | 5,936 | 8,476 | 508 |

HOW TO ORDER

O J 4 14 06 TC

- Coating code ←
- Ferrite core material ←
- Used for all ferrite types ←
- Approximate diameter in mm ←
- Approximate height in mm ←
- Geometry code ←

| Coating Code | Coating Material | Temperature Rating | Voltage Breakdown (wire to wire) |
|--------------|------------------|--------------------|----------------------------------|
| 0 | Bare Core | N/A | N/A |
| Y | Parylene | 130°C | 600V |
| Z | Epoxy | 200°C | 1000V |

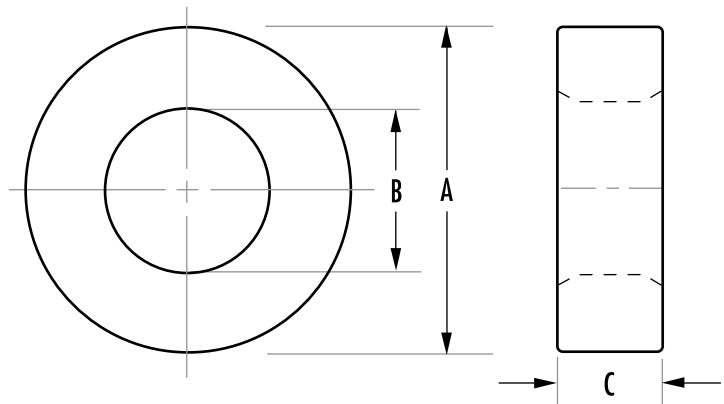



| SIZE (mm) | ORDERING CODE | MAGNETIC DATA | | | | | | HARDWARE |
|--------------------|------------------|---------------------|-----------------------------------|-----------------------------------|--------------------------------|-------------------------|--------------------------|------------------|
| | | I _e (mm) | A _e (mm ²) | V _e (mm ³) | Window Area (cm ²) | WaAc (cm ⁴) | Weight (grams per piece) | Headers & Mounts |
| 2.54 x 1.27 x 1.27 | O_40200TC | 5.5 | 0.77 | 4.3 | 0.01 | 0.0001 | 0.03 | SMH07058A |
| 3.46 x 1.78 x 1.27 | O_40301TC | 7.65 | 1.03 | 7.87 | 0.02 | 0.0003 | 0.04 | SMH07058A |
| 3.94 x 2.24 x 1.27 | O_40502TC | 9.2 | 1.05 | 9.7 | 0.03 | 0.0004 | 0.05 | SMH07058A |
| 3.94 x 2.24 x 2.54 | O_40503TC | 9.2 | 2.1 | 19.4 | 0.03 | 0.0008 | 0.10 | SMH07058A |
| 4.83 x 2.29 x 1.27 | O_40401TC | 10.2 | 1.5 | 15.7 | 0.04 | 0.0006 | 0.09 | SMH07058A |
| 4.83 x 2.29 x 2.54 | O_40402TC | 10.2 | 3.1 | 31.5 | 0.04 | 0.001 | 0.17 | SMH07058A |
| 5.84 x 3.05 x 1.52 | O_40601TC | 13.0 | 2.0 | 26.7 | 0.07 | 0.001 | 0.14 | SMH07058A |
| 5.84 x 3.05 x 3.18 | O_40603TC | 13.0 | 4.3 | 56.0 | 0.07 | 0.003 | 0.30 | SMH07058A |
| 7.62 x 3.18 x 4.78 | O_40705TC | 15.0 | 9.9 | 149 | 0.07 | 0.008 | 0.90 | SMH07058A |
| 9.53 x 5.59 x 7.11 | O_40907TC | 22.7 | 13.7 | 310 | 0.24 | 0.03 | 1.60 | |
| 9.53 x 4.75 x 3.18 | O_41003TC | 20.7 | 7.3 | 151 | 0.17 | 0.01 | 0.82 | |
| 9.53 x 4.75 x 4.78 | O_41005TC | 20.7 | 10.9 | 227 | 0.17 | 0.02 | 1.20 | |
| 12.7 x 5.16 x 6.35 | O_41206TC | 25.0 | 22.0 | 550 | 0.20 | 0.05 | 3.30 | |
| 12.7 x 8.14 x 3.18 | O_41303TC | 31.7 | 7.1 | 226 | 0.49 | 0.04 | 1.20 | |
| 12.7 x 8.14 x 3.89 | O_41304TC | 31.7 | 8.7 | 276 | 0.49 | 0.05 | 1.44 | |
| 12.7 x 8.14 x 5.08 | O_41305TC | 31.7 | 11.4 | 361 | 0.49 | 0.06 | 1.90 | |
| 12.7 x 8.14 x 6.35 | O_41306TC | 31.7 | 14.2 | 451 | 0.49 | 0.07 | 2.40 | |

Refer to page 62 for additional hardware information.

| SIZE (mm) | ORDERING CODE | BARE NOMINAL DIMENSIONS (mm) | | | Y/Z COATED LIMITING DIMENSIONS (mm) | | | |
|--------------------|------------------|------------------------------|--------|--------|-------------------------------------|--------|--------|--------|
| | | OD (A) | ID (B) | HT (C) | COATING | OD max | ID min | HT max |
| 2.54 x 1.27 x 1.27 | O_40200TC | 2.54 | 1.27 | 1.27 | Y | 2.79 | 1.02 | 1.52 |
| 3.46 x 1.78 x 1.27 | O_40301TC | 3.46 | 1.78 | 1.27 | Y | 3.79 | 1.54 | 1.53 |
| 3.94 x 2.24 x 1.27 | O_40502TC | 3.94 | 2.24 | 1.27 | Y | 4.22 | 1.95 | 1.53 |
| 3.94 x 2.24 x 2.54 | O_40503TC | 3.94 | 2.24 | 2.54 | Y | 4.22 | 1.95 | 2.87 |
| 4.83 x 2.29 x 1.27 | O_40401TC | 4.83 | 2.29 | 1.27 | Y | 5.11 | 2 | 1.53 |
| 4.83 x 2.29 x 2.54 | O_40402TC | 4.83 | 2.29 | 2.54 | Y | 5.11 | 2 | 2.87 |
| 5.84 x 3.05 x 1.52 | O_40601TC | 5.84 | 3.05 | 1.52 | Y | 6.2 | 2.69 | 1.78 |
| 5.84 x 3.05 x 3.18 | O_40603TC | 5.84 | 3.05 | 3.18 | Y | 6.2 | 2.69 | 3.51 |
| 7.62 x 3.18 x 4.78 | O_40705TC | 7.62 | 3.18 | 4.78 | Y | 7.95 | 2.84 | 4.98 |
| 9.53 x 5.59 x 7.11 | O_40907TC | 9.53 | 5.59 | 7.11 | Z | 10.17 | 4.95 | 7.66 |
| 9.53 x 4.75 x 3.18 | O_41003TC | 9.53 | 4.75 | 3.18 | Z | 10.17 | 4.2 | 3.73 |
| 9.53 x 4.75 x 4.78 | O_41005TC | 9.53 | 4.75 | 4.78 | Z | 10.17 | 4.2 | 5.33 |
| 12.7 x 5.16 x 6.35 | O_41206TC | 12.7 | 5.16 | 6.35 | Z | 13.34 | 4.52 | 6.91 |
| 12.7 x 8.14 x 3.18 | O_41303TC | 12.7 | 8.14 | 3.18 | Z | 13.34 | 7.29 | 3.69 |
| 12.7 x 8.14 x 3.89 | O_41304TC | 12.7 | 8.14 | 3.89 | Z | 13.34 | 7.29 | 4.47 |
| 12.7 x 8.14 x 5.08 | O_41305TC | 12.7 | 8.14 | 5.08 | Z | 13.34 | 7.29 | 5.75 |
| 12.7 x 8.14 x 6.35 | O_41306TC | 12.7 | 8.14 | 6.35 | Z | 13.34 | 7.29 | 6.91 |

W material and M material limit dimensions will vary, please refer to the specific part datasheet. For limiting dimensions of other available coatings, please refer to the specific part datasheet.

Toroids

12.7 mm – 25.34 mm



| SIZE (mm) | ORDERING CODE | Y | Z | NOMINAL A_L (mH/1000T) | | | | | | | | |
|----------------------|------------------|---|---|--------------------------|---------|---------|---------|---------|---------|---------|---------|---------|
| | | | | L ± 25% | R ± 25% | P ± 25% | F ± 20% | T ± 25% | J ± 20% | W ± 30% | M ± 30% | C ± 25% |
| 12.7 x 7.14 x 5.08 | 0_41405TC | | ✓ | 526 | 1,320 | 1,440 | 1,730 | | 2,890 | 5,780 | | 500 |
| 12.7 x 7.14 x 6.35 | 0_41406TC | | ✓ | 658 | 1,660 | 1,805 | 2,166 | | 3,612 | 7,224 | 10,974 | 625 |
| 12.7 x 7.14 x 4.78 | 0_41407TC | | ✓ | 495 | 1,240 | 1,356 | 1,630 | | 2,715 | 5,430 | | 470 |
| 12.7 x 7.14 x 7.62 | 0_41410TC | | ✓ | 790 | 1,990 | 2,162 | 2,595 | | 4,335 | 8,675 | | 790 |
| 13.2 x 7.37 x 3.96 | 0_41506TC | | ✓ | 415 | 1,020 | 1,111 | 1,334 | 1,320 | 2,295 | 4,590 | | 315 |
| 13.6 x 7.01 x 3.51 | 0_41435TC | | ✓ | 419 | 1,040 | 1,130 | 1,350 | | 2,260 | 4,520 | | 418 |
| 14.0 x 8.99 x 5.0 | 0_41450TC | | ✓ | 399 | 990 | 1,080 | 1,290 | | 2,160 | 4,320 | | 397 |
| 15.9 x 9.07 x 4.7 | 0_41605TC | | ✓ | 475 | 1,260 | 1,375 | 1,650 | 1,580 | 2,760 | 5,520 | 7,917 | 475 |
| 15.9 x 9.07 x 5.7 | 0_41606TC | | ✓ | | | | 1,920 | | | | | |
| 15.9 x 9.07 x 6.84 | 0_41607TC | | ✓ | | | | 2,300 | | | | | |
| 15.9 x 9.07 x 9.4 | 0_41610TC | | ✓ | 950 | 2,450 | 2,660 | 3,200 | | 5,410 | 10,600 | | 950 |
| 18.4 x 9.75 x 10.3 | 0_41809TC | | ✓ | 1,177 | 2,810 | 3,050 | 3,660 | | 6,115 | 12,200 | | 1,177 |
| 20.6 x 12.7 x 6.35 | 0_42106TC | | ✓ | 553 | 1,380 | 1,500 | 1,680 | | 2,800 | 5,600 | | 553 |
| 20.6 x 12.7 x 8.89 | 0_42109TC | | ✓ | 774 | 1,930 | 2,100 | 2,520 | | 4,200 | 8,400 | | 774 |
| 22.1 x 13.7 x 6.35 | 0_42206TC | | ✓ | 547 | 1,380 | 1,510 | 1,812 | 1,790 | 3,020 | 6,040 | 8,494 | 538 |
| 22.1 x 13.7 x 7.9 | 0_42207TC | | ✓ | 680 | 1,720 | 1,875 | 2,250 | | 3,700 | 7,400 | | 671 |
| 22.1 x 13.7 x 12.7 | 0_42212TC | | ✓ | 1,093 | 2,770 | 3,020 | 3,624 | | 6,040 | 12,080 | 17,313 | 1,084 |
| 25.34 x 12.7 x 9.53 | 0_42506TC | | ✓ | | | | 3,627 | | | | | |
| 25.34 x 15.45 x 7.66 | 0_42507TC | | ✓ | 705 | 1,800 | 1,958 | 2,348 | | 3,913 | 7,825 | 11,072 | 690 |
| 25.34 x 15.45 x 10.0 | 0_42508TC | | ✓ | 891 | 2,220 | 2,420 | 2,900 | | 4,830 | 9,660 | | |

HOW TO ORDER

O J 4 14 06 TC

- Coating code ← O
- Ferrite core material ← J
- Used for all ferrite types ← 4
- Approximate diameter in mm ← 14
- Approximate height in mm ← 06
- Geometry code ← TC

| Coating Code | Coating Material | Temperature Rating | Voltage Breakdown (wire to wire) |
|--------------|------------------|--------------------|----------------------------------|
| O | Bare Core | N/A | N/A |
| Y | Parylene | 130°C | 600V |
| Z | Epoxy | 200°C | 1000V |

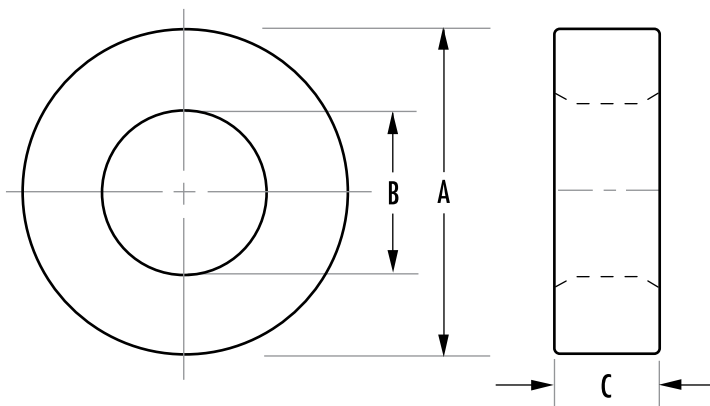



Refer to page 62 for additional hardware information.

| SIZE (mm) | ORDERING CODE | MAGNETIC DATA | | | | | | HARDWARE |
|----------------------|------------------|---------------------|-----------------------------------|-----------------------------------|--------------------------------|-------------------------|-------------------|------------------|
| | | I _e (mm) | A _e (mm ²) | V _e (mm ³) | Window Area (cm ²) | WaAc (cm ⁴) | Weight (grams/pc) | Headers & Mounts |
| 12.7 x 7.14 x 5.08 | 0_41405TC | 29.5 | 13.7 | 405 | 0.40 | 0.05 | 2.03 | |
| 12.7 x 7.14 x 6.35 | 0_41406TC | 29.5 | 17.1 | 507 | 0.40 | 0.07 | 2.70 | TVB22066A |
| 12.7 x 7.14 x 4.78 | 0_41407TC | 29.5 | 12.9 | 381 | 0.40 | 0.05 | 1.90 | TVB22066A |
| 12.7 x 7.14 x 7.62 | 0_41410TC | 29.5 | 20.6 | 608 | 0.40 | 0.17 | 3.04 | |
| 13.2 x 7.37 x 3.96 | 0_41506TC | 30.6 | 11.2 | 343 | 0.42 | 0.05 | 1.9 | TVB22066A |
| 13.6 x 7.01 x 3.51 | 0_41435TC | 30.1 | 11.1 | 335 | 0.36 | 0.04 | 1.7 | |
| 14.0 x 8.99 x 5.0 | 0_41450TC | 35.0 | 12.3 | 430 | 0.63 | 0.08 | 2.2 | TVB22066A |
| 15.9 x 9.07 x 4.7 | 0_41605TC | 37.2 | 15.6 | 580 | 0.62 | 0.10 | 2.8 | TVB22066A |
| 15.9 x 9.07 x 5.7 | 0_41606TC | 37.2 | 19.0 | 706 | 0.62 | 0.13 | 4.1 | TVB22066A |
| 15.9 x 9.07 x 6.84 | 0_41607TC | 37.2 | 22.8 | 847 | 0.64 | 0.15 | 4.5 | TVB22066A |
| 15.9 x 9.07 x 9.4 | 0_41610TC | 37.2 | 31.2 | 1,164 | 0.62 | 0.20 | 5.8 | |
| 18.4 x 9.75 x 10.3 | 0_41809TC | 41.4 | 43.1 | 1,783 | 0.74 | 0.32 | 9.9 | TVB22066A |
| 20.6 x 12.7 x 6.35 | 0_42106TC | 50.3 | 24.6 | 1,238 | 1.27 | 0.31 | 5.4 | TVB22066A |
| 20.6 x 12.7 x 8.89 | 0_42109TC | 50.3 | 34.4 | 1,733 | 1.27 | 0.43 | 8.1 | TVB22066A |
| 22.1 x 13.7 x 6.35 | 0_42206TC | 54.1 | 26.2 | 1,417 | 1.48 | 0.39 | 6.4 | TVB22066A |
| 22.1 x 13.7 x 7.9 | 0_42207TC | 54.2 | 32.5 | 1,763 | 1.48 | 0.48 | 8.5 | TVB22066A |
| 22.1 x 13.7 x 12.7 | 0_42212TC | 51.9 | 52.3 | 2,834 | 1.48 | 0.77 | 13.5 | TVB22066A |
| 25.34 x 12.7 x 9.53 | 0_42506TC | 55.3 | 57.9 | 3,199 | 1.26 | 0.73 | 25.0 | TVH25074A |
| 25.34 x 15.45 x 7.66 | 0_42507TC | 61.5 | 37.1 | 2,284 | 1.89 | 0.69 | 11.6 | TVH25074A |
| 25.34 x 15.45 x 10.0 | 0_42508TC | 61.5 | 48.0 | 2,981 | 1.89 | 0.89 | 14.9 | TVH25074A |

| SIZE (mm) | ORDERING CODE | BARE NOMINAL DIMENSIONS (mm) | | | Z-COATED LIMITING DIMENSIONS (mm) | | |
|----------------------|------------------|------------------------------|--------|--------|-----------------------------------|--------|--------|
| | | OD (A) | ID (B) | HT (C) | OD max | ID min | HT max |
| 12.7 x 7.14 x 5.08 | 0_41405TC | 12.7 | 7.14 | 5.08 | 13.34 | 6.5 | 5.75 |
| 12.7 x 7.14 x 6.35 | 0_41406TC | 12.7 | 7.14 | 6.35 | 13.34 | 6.5 | 6.91 |
| 12.7 x 7.14 x 4.78 | 0_41407TC | 12.7 | 7.14 | 4.78 | 13.34 | 6.5 | 5.29 |
| 12.7 x 7.14 x 7.62 | 0_41410TC | 12.7 | 7.14 | 7.62 | 13.34 | 6.5 | 8.26 |
| 13.2 x 7.37 x 3.96 | 0_41506TC | 13.2 | 7.37 | 3.96 | 13.84 | 6.73 | 4.47 |
| 13.6 x 7.01 x 3.51 | 0_41435TC | 13.6 | 7.01 | 3.51 | 14.23 | 6.37 | 4.02 |
| 14.0 x 8.99 x 5.0 | 0_41450TC | 14.0 | 8.99 | 5.0 | 14.64 | 8.35 | 5.52 |
| 15.9 x 9.07 x 4.7 | 0_41605TC | 15.9 | 9.07 | 4.7 | 16.64 | 8.12 | 5.21 |
| 15.9 x 9.07 x 5.7 | 0_41606TC | 15.9 | 9.07 | 5.7 | 16.59 | 7.92 | 6.4 |
| 15.9 x 9.07 x 6.84 | 0_41607TC | 15.9 | 9.07 | 6.84 | 16.64 | 8.12 | 7.51 |
| 15.9 x 9.07 x 9.4 | 0_41610TC | 15.9 | 9.07 | 9.4 | 16.64 | 8.12 | 10.03 |
| 18.4 x 9.75 x 10.3 | 0_41809TC | 18.4 | 9.75 | 10.3 | 19.21 | 8.99 | 10.9 |
| 20.6 x 12.7 x 6.35 | 0_42106TC | 20.6 | 12.7 | 6.35 | 21.34 | 11.93 | 6.91 |
| 20.6 x 12.7 x 8.89 | 0_42109TC | 20.6 | 12.7 | 8.89 | 21.34 | 11.93 | 9.53 |
| 22.1 x 13.7 x 6.35 | 0_42206TC | 22.1 | 13.7 | 6.35 | 22.86 | 12.95 | 6.91 |
| 22.1 x 13.7 x 7.9 | 0_42207TC | 22.1 | 13.7 | 7.9 | 22.86 | 12.95 | 8.56 |
| 22.1 x 13.7 x 12.7 | 0_42212TC | 22.1 | 13.7 | 12.7 | 22.86 | 12.95 | 13.34 |
| 25.34 x 12.7 x 9.53 | 0_42506TC | 25.34 | 12.7 | 9.53 | 26.29 | 12.83 | 10.16 |
| 25.34 x 15.45 x 7.66 | 0_42507TC | 25.34 | 15.45 | 7.66 | 26.29 | 14.6 | 8.56 |
| 25.34 x 15.45 x 10.0 | 0_42508TC | 25.34 | 15.45 | 10.0 | 26.29 | 14.6 | 10.65 |

Toroids

26.9 mm – 46.9 mm



| SIZE (mm) | ORDERING CODE | Y | Z | NOMINAL A_L (mH/1000T) | | | | | |
|--------------------|------------------|---|---|--------------------------|-------------|-------------|-------------|-------------|-------------|
| | | | | R \pm 25% | P \pm 25% | F \pm 20% | T \pm 25% | J \pm 20% | W \pm 30% |
| 26.9 x 14.2 x 12.2 | 0_42712TC | | ✓ | 3,610 | 3,920 | 4,710 | | 7,650 | 15,300 |
| 29 x 19 x 7.43 | 0_42908TC | | ✓ | 1,450 | 1,585 | 1,902 | | 3,170 | 6,340 |
| 29 x 19 x 15.2 | 0_42915TC | | ✓ | 2,960 | 3,222 | 3,868 | | 6,447 | 12,894 |
| 30.8 x 19.1 x 12.7 | 0_43113TC | | ✓ | 2,850 | 3,100 | 3,720 | | 6,200 | 12,400 |
| 32 x 15 x 4.5 | 0_43205TC | | ✓ | 1,480 | 1,610 | 1,930 | | 3,220 | 6,440 |
| 36 x 23 x 10 | 0_43610TC | | ✓ | 2,030 | 2,210 | 2,726 | | 4,543 | 9,085 |
| 36 x 23 x 15 | 0_43615TC | | ✓ | 3,100 | 3,366 | 4,040 | | 6,736 | 13,400 |
| 36 x 23 x 20 | 0_43620TC | | ✓ | | | | | 9,086 | |
| 38.1 x 19 x 6.35 | 0_43806TC | | ✓ | 2,020 | 2,200 | 2,640 | | 4,400 | 8,800 |
| 38.1 x 19 x 12.7 | 0_43813TC | | ✓ | 3,850 | 4,185 | 5,020 | 5,190 | 8,365 | 16,700 |
| 38.1 x 19 x 25.4 | 0_43825TC | | ✓ | 8,060 | 8,762 | 10,040 | | 16,730 | 33,400 |
| 41.8 x 26.2 x 18 | 0_44015TC | | ✓ | 3,860 | 4,200 | 5,040 | 5,040 | 8,408 | 16,816 |
| 44.3 x 19 x 15.9 | 0_44416TC | | ✓ | 5,360 | 5,830 | 7,000 | | 11,600 | 23,200 |
| 44.3 x 19 x 19.1 | 0_44419TC | | ✓ | | 7,970 | 9,550 | | | |
| 46.9 x 27 x 15 | 0_44715TC | | ✓ | 3,700 | 4,030 | 4,840 | | 8,075 | 16,100 |

HOW TO ORDER

O J 4 14 06 TC

- Coating code ←
- Ferrite core material ←
- Used for all ferrite types ←
- Approximate diameter in mm ←
- Approximate height in mm ←
- Geometry code ←

| Coating Code | Coating Material | Temperature Rating | Voltage Breakdown (wire to wire) |
|--------------|------------------|--------------------|----------------------------------|
| O | Bare Core | N/A | N/A |
| Y | Parylene | 130°C | 600V |
| Z | Epoxy | 200°C | 1000V |

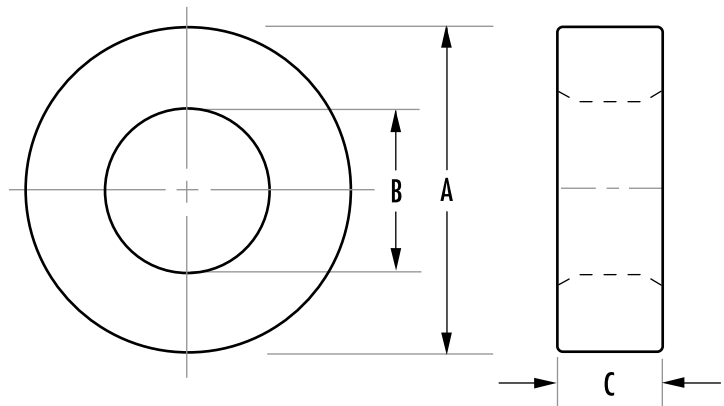



| SIZE (mm) | ORDERING CODE | MAGNETIC DATA | | | | | | HARDWARE |
|--------------------|------------------|---------------------|-----------------------------------|-----------------------------------|--------------------------------|-------------------------|--------------------------|------------------|
| | | I _e (mm) | A _e (mm ²) | V _e (mm ³) | Window Area (cm ²) | WaAc (cm ⁴) | Weight (grams per piece) | Headers & Mounts |
| 26.9 x 14.2 x 12.2 | 0_42712TC | 60.2 | 73.2 | 4,410 | 1.57 | 1.16 | 22.5 | |
| 29 x 19 x 7.43 | 0_42908TC | 73.2 | 37.0 | 2,679 | 2.84 | 1.05 | 12.9 | TVH25074A |
| 29 x 19 x 15.2 | 0_42915TC | 73.2 | 74.9 | 5,481 | 2.84 | 2.13 | 27.6 | TVH25074A |
| 30.8 x 19.1 x 12.7 | 0_43113TC | 75.4 | 73.6 | 5,547 | 2.83 | 2.11 | 29.3 | TVB2908TA |
| 32 x 15 x 4.5 | 0_43205TC | 67.2 | 36.4 | 2,451 | 0.34 | 0.61 | 12.9 | TVH38134A |
| 36 x 23 x 10 | 0_43610TC | 89.7 | 63.9 | 5,731 | 4.15 | 2.65 | 29.4 | TVH38134A |
| 36 x 23 x 15 | 0_43615TC | 89.6 | 95.9 | 8,596 | 2.85 | 3.98 | 44 | TVH38134A |
| 36 x 23 x 20 | 0_43620TC | 89.6 | 128 | 11,461 | 4.15 | 5.31 | 54 | |
| 38.1 x 19 x 6.35 | 0_43806TC | 82.9 | 58.3 | 4,826 | 2.85 | 1.66 | 26.4 | TVH38134A |
| 38.1 x 19 x 12.7 | 0_43813TC | 82.9 | 115.6 | 9,652 | 2.85 | 3.28 | 51.7 | TVH38134A |
| 38.1 x 19 x 25.4 | 0_43825TC | 82.8 | 233 | 19,304 | 2.85 | 6.56 | 103.4 | TVH38134A |
| 41.8 x 26.2 x 18 | 0_44015TC | 103 | 138 | 14,205 | 5.39 | 7.44 | 68.9 | TVH49164A |
| 44.3 x 19 x 15.9 | 0_44416TC | 88.0 | 187 | 16,559 | 2.85 | 5.33 | 80.8 | TVH49164A |
| 44.3 x 19 x 19.1 | 0_44419TC | 88.0 | 228 | 20,146 | 2.85 | 6.50 | 107.9 | |
| 46.9 x 27 x 15 | 0_44715TC | 110.4 | 145.5 | 16,063 | 5.72 | 8.34 | 84.0 | TVH49164A |

Refer to page 62 for additional hardware information.

| SIZE (mm) | ORDERING CODE | BARE NOMINAL DIMENSIONS (mm) | | | Z-COATED LIMITING DIMENSIONS (mm) | | |
|--------------------|------------------|------------------------------|--------|--------|-----------------------------------|--------|--------|
| | | OD (A) | ID (B) | HT (C) | OD max | ID min | HT max |
| 26.9 x 14.2 x 12.2 | 0_42712TC | 26.9 | 14.2 | 12.2 | 28.01 | 13.01 | 13 |
| 29 x 19 x 7.43 | 0_42908TC | 29.0 | 19.0 | 7.43 | 29.9 | 18.11 | 8.06 |
| 29 x 19 x 15.2 | 0_42915TC | 29.0 | 19.0 | 15.2 | 30.15 | 17.85 | 16.21 |
| 30.8 x 19.1 x 12.7 | 0_43113TC | 30.8 | 19.1 | 12.7 | 31.88 | 18.11 | 13.64 |
| 32 x 15 x 4.5 | 0_43205TC | 32.0 | 15.0 | 4.5 | 32.9 | 14.12 | 5.01 |
| 36 x 23 x 10 | 0_43610TC | 36.0 | 23.0 | 10.0 | 37.15 | 22.05 | 10.65 |
| 36 x 23 x 15 | 0_43615TC | 36.0 | 23.0 | 15.0 | 37.15 | 22.05 | 15.6 |
| 36 x 23 x 20 | 0_43620TC | 36.0 | 23.0 | 20.0 | 37.15 | 22.05 | 20.65 |
| 38.1 x 19 x 6.35 | 0_43806TC | 38.1 | 19.0 | 6.35 | 39.25 | 17.9 | 6.91 |
| 38.1 x 19 x 12.7 | 0_43813TC | 38.1 | 19.0 | 12.7 | 39.25 | 17.9 | 13.34 |
| 38.1 x 19 x 25.4 | 0_43825TC | 38.1 | 19.0 | 25.4 | 39.25 | 17.9 | 26.29 |
| 41.8 x 26.2 x 18 | 0_44015TC | 41.8 | 26.2 | 18.0 | 43.15 | 25.15 | 19.2 |
| 44.3 x 19 x 15.9 | 0_44416TC | 44.3 | 19.0 | 15.7 | 45.6 | 17.9 | 16.64 |
| 44.3 x 19 x 19.1 | 0_44419TC | 44.3 | 19.0 | 19.1 | 45.6 | 17.9 | 20.14 |
| 46.9 x 27 x 15 | 0_44715TC | 46.9 | 27.0 | 15.0 | 48.04 | 25.85 | 15.65 |

W-perm limiting dimensions will vary, please refer to the specific part datasheet. For limiting dimensions of other available coatings, please refer to the specific part datasheet.

Toroids

49.1 mm – 140 mm



| SIZE (mm) | ORDERING CODE | Y | Z | NOMINAL A_L (mH/1000T) | | | | | |
|-----------------------|------------------|---|---|--------------------------|-------------|-------------|-------------|-------------|-------------|
| | | | | R \pm 25% | P \pm 25% | F \pm 20% | T \pm 25% | J \pm 20% | W \pm 30% |
| 49.1 x 33.8 x 15.9 | 0_44916TC | | ✓ | 2,710 | 2,950 | 3,540 | | 5,900 | 11,800 |
| 49.1 x 31.8 x 15.9 | 0_44920TC | | ✓ | 2,790 | 3,032 | 3,640 | | 6,065 | 12,130 |
| 49.1 x 31.8 x 19.05 | 0_44925TC | | ✓ | 3,420 | 3,718 | 4,460 | | 7,435 | 14,870 |
| 49.1 x 33.8 x 31.3 | 0_44932TC | | ✓ | 5,430 | 5,900 | 7,080 | | 11,800 | 23,600 |
| 60.96 x 41.78 x 12.7 | 0_46013TC | | ✓ | | 1,960 | | | 4,800 | 9,483 |
| 60.96 x 41.78 x 19.05 | 0_46019TC | | ✓ | | | | | 7,100 | |
| 61 x 35.6 x 12.7 | 0_46113TC | | ✓ | 3,140 | 3,491 | 4,107 | | 6,845 | 13,690 |
| 63 x 38 x 24.5 | 0_46325TC | | ✓ | | | | | | 21,056 |
| 63 x 38 x 24.5 | 0_46326TC | | ✓ | 5,770 | 6,270 | 7,530 | | 12,500 | |
| 73.7 x 38.9 x 12.5 | 0_47313TC | | ✓ | 3,700 | 4,024 | 4,880 | 5,790 | 8,140 | 16,280 |
| 73.7 x 38.9 x 25.2 | 0_47325TC | | ✓ | 7,400 | 8,050 | 9,760 | | 16,280 | |
| 73.7 x 38.9 x 25.4 | 0_47326TC | | ✓ | | | | | | 27,610 |
| 85.7 x 55.5 x 12.7 | 0_48613TC | | ✓ | 2,510 | 2,726 | 3,310 | | 5,520 | 11,040 |
| 85.7 x 55.5 x 19.05 | 0_48619TC | | ✓ | | | | | | 14,900 |
| 85.7 x 55.5 x 25.4 | 0_48625TC | | ✓ | 5,040 | 5,480 | 6,570 | | 10,960 | |
| 85.7 x 55.5 x 25.4 | 0_48626TC | | ✓ | | | | | | 18,760 |
| 102 x 65.8 x 15 | 0_49715TC | | ✓ | 3,025 | 3,464 | 3,945 | | 6,575 | 11,178 |
| 107 x 65 x 18 | 0_49718TC | | ✓ | 4,127 | 4,486 | 5,383 | | 8,972 | 15,252 |
| 107 x 65 x 25 | 0_49725TC | | ✓ | 5,732 | 6,230 | 7,477 | | 12,461 | 21,184 |
| 140 x 106 x 25 | 0_49740TC | | ✓ | 3,200 | 3,477 | 4,173 | | 6,955 | 11,823 |

HOW TO ORDER

O J 4 14 06 TC

Coating code ←
 Ferrite core material ←
 Used for all ferrite types ←
 Approximate diameter in mm ←
 Approximate height in mm ←
 Geometry code ←

| Coating Code | Coating Material | Temperature Rating | Voltage Breakdown (wire to wire) |
|--------------|------------------|--------------------|----------------------------------|
| 0 | Bare Core | N/A | N/A |
| Y | Parylene | 130°C | 600V |
| Z | Epoxy | 200°C | 1000V |

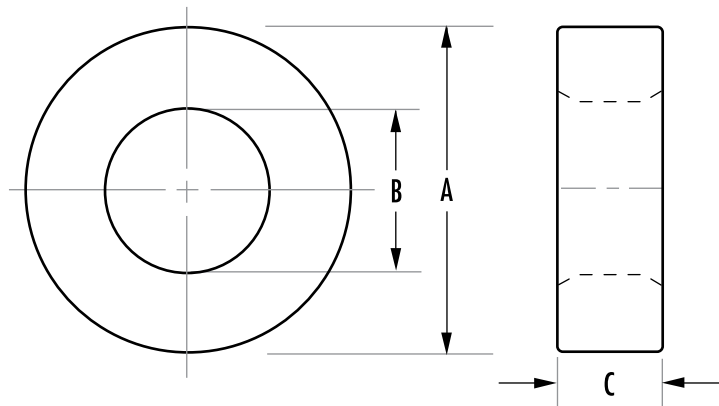



Refer to page 62 for additional hardware information.

| SIZE (mm) | ORDERING CODE | MAGNETIC DATA | | | | | | HARDWARE |
|-----------------------|------------------|---------------------|-----------------------------------|-----------------------------------|--------------------------------|-------------------------|-------------------|------------------|
| | | I _e (mm) | A _e (mm ²) | V _e (mm ³) | Window Area (cm ²) | WaAc (cm ⁴) | Weight (grams/pc) | Headers & Mounts |
| 49.1 x 33.8 x 15.9 | 0_44916TC | 127 | 120 | 15,298 | 8.99 | 10.6 | 75.3 | TVH49164A |
| 49.1 x 31.8 x 15.9 | 0_44920TC | 123.2 | 135.4 | 16,676 | 7.94 | 9.45 | 83 | TVH49164A |
| 49.1 x 31.8 x 19.05 | 0_44925TC | 123 | 162 | 20,000 | 7.94 | 12.8 | 98 | TVH49164A |
| 49.1 x 33.8 x 31.3 | 0_44932TC | 127 | 237 | 30,100 | 8.99 | 21.2 | 150.6 | TVH49164A |
| 60.96 x 41.78 x 12.7 | 0_46013TC | 157.6 | 120.4 | 18,968 | 13.68 | 16.48 | 94 | |
| 60.96 x 41.78 x 19.05 | 0_46019TC | 157.6 | 180.5 | 28,453 | 13.68 | 24.7 | 141 | |
| 61 x 35.6 x 12.7 | 0_46113TC | 144.6 | 157.4 | 22,774 | 9.93 | 15.5 | 113 | TVH49164A |
| 63 x 38 x 24.5 | 0_46325TC | 152 | 300 | 45,598 | 11.1 | 33.2 | 225 | TVH49164A |
| 63 x 38 x 24.5 | 0_46326TC | 152 | 300 | 45,600 | 11.3 | 33.9 | 225 | TVH49164A |
| 73.7 x 38.9 x 12.5 | 0_47313TC | 165 | 210 | 34,771 | 11.9 | 25 | 172 | |
| 73.7 x 38.9 x 25.2 | 0_47325TC | 165 | 423 | 70,099 | 11.9 | 50.3 | 347 | |
| 73.7 x 38.9 x 25.4 | 0_47326TC | 165 | 427 | 70,595 | 11.9 | 50.8 | 350 | |
| 85.7 x 55.5 x 12.7 | 0_48613TC | 214.9 | 188.8 | 40,582 | 24.2 | 45.7 | 201 | |
| 85.7 x 55.5 x 19.05 | 0_48619TC | 215 | 283 | 60,874 | 24.2 | 68.4 | 302 | |
| 85.7 x 55.5 x 25.4 | 0_48625TC | 215 | 375 | 80,700 | 24.2 | 90.8 | 399 | |
| 85.7 x 55.5 x 25.4 | 0_48626TC | 215 | 377 | 81,165 | 24.2 | 91.2 | 402 | |
| 102 x 65.8 x 15 | 0_49715TC | 255.3 | 267.2 | 68,821 | 34 | 90.8 | 341 | |
| 107 x 65 x 18 | 0_49718TC | 259.31 | 370.27 | 96,013 | 28.6 | 106 | 475 | |
| 107 x 65 x 25 | 0_49725TC | 259.31 | 514.3 | 133,351 | 33.2 | 171 | 660 | |
| 140 x 106 x 25 | 0_49740TC | 381.5 | 422.3 | 161,086 | 88.2 | 372 | 797 | |

| SIZE (mm) | ORDERING CODE | BARE NOMINAL DIMENSIONS (mm) | | | Z-COATED LIMITING DIMENSIONS (mm) | | |
|-----------------------|------------------|------------------------------|--------|--------|-----------------------------------|--------|---------|
| | | OD (A) | ID (B) | HT (C) | OD max | ID min | Ht. max |
| 49.1 x 33.8 x 15.9 | 0_44916TC | 49.1 | 33.8 | 15.9 | 50.22 | 32.69 | 16.64 |
| 49.1 x 31.8 x 15.9 | 0_44920TC | 49.1 | 31.8 | 15.9 | 50.22 | 30.65 | 16.64 |
| 49.1 x 31.8 x 19.05 | 0_44925TC | 49.1 | 31.8 | 19.05 | 50.22 | 30.65 | 19.82 |
| 49.1 x 33.8 x 31.3 | 0_44932TC | 49.1 | 33.8 | 31.3 | 50.22 | 32.69 | 32.64 |
| 60.96 x 41.78 x 12.7 | 0_46013TC | 60.96 | 41.78 | 12.7 | 62.23 | 40.51 | 13.34 |
| 60.96 x 41.78 x 19.05 | 0_46019TC | 60.96 | 41.78 | 19.05 | 62.23 | 40.51 | 19.95 |
| 61 x 35.6 x 12.7 | 0_46113TC | 61 | 35.6 | 12.7 | 62.23 | 34.29 | 13.34 |
| 63 x 38 x 24.5 | 0_46325TC | 63 | 38 | 24.5 | 64.9 | 35.97 | 25.96 |
| 63 x 38 x 24.5 | 0_46326TC | 63 | 38 | 24.5 | 64.9 | 36.4 | 25.8 |
| 73.7 x 38.9 x 12.5 | 0_47313TC | 73.7 | 38.9 | 12.5 | 75.06 | 37.46 | 13.34 |
| 73.7 x 38.9 x 25.2 | 0_47325TC | 73.7 | 38.9 | 25.2 | 75.06 | 37.46 | 26.29 |
| 73.7 x 38.9 x 25.4 | 0_47326TC | 73.7 | 38.9 | 25.4 | 75.56 | 36.96 | 26.92 |
| 85.7 x 55.5 x 12.7 | 0_48613TC | 85.7 | 55.5 | 12.7 | 87.38 | 53.89 | 13.34 |
| 85.7 x 55.5 x 19.05 | 0_48619TC | 85.7 | 55.5 | 19.05 | 88.02 | 53.26 | 20.97 |
| 85.7 x 55.5 x 25.4 | 0_48625TC | 85.7 | 55.5 | 25.4 | 87.38 | 53.89 | 26.65 |
| 85.7 x 55.5 x 25.4 | 0_48626TC | 85.7 | 55.5 | 25.4 | 88.02 | 53.26 | 26.92 |
| 102 x 65.8 x 15 | 0_49715TC | 102 | 65.8 | 15 | 104.5 | 64.1 | 16 |
| 107 x 65 x 18 | 0_49718TC | 107 | 65 | 18 | 109.5 | 63.3 | 18.85 |
| 107 x 65 x 25 | 0_49725TC | 107 | 65 | 25 | 109.5 | 63.3 | 26.05 |
| 140 x 106 x 25 | 0_49740TC | 140 | 106 | 25 | 143.5 | 103.6 | 26.4 |

E, I Cores

9 mm – 35 mm

E cores are less expensive than pot cores and have the advantage of simple bobbin winding plus easy assembly. E cores do not, however, offer self-shielding. Lamination size E cores are available to fit commercially offered bobbins previously designed to fit the strip stampings of standard lamination sizes. Metric and DIN sizes are also available. E cores can be pressed to different thicknesses, providing a selection of cross-sectional areas. E cores can be mounted in different directions and, if desired, provide a low profile.

Typical applications for E cores include differential mode, power and telecom inductors, as well as broadband, power, converter and inverter transformers.

| TYPE/SIZE | ORDERING CODE | NOMINAL A_L (mH/1000T) | | | | | | |
|------------|------------------|--------------------------|-------|-------|-------|-------|-------|--------|
| | | L | R | P | F | T | J | W |
| E 9/4/2 | 0_40904EC | 280 | 493 | 540 | 650 | | 1,040 | |
| E 13/7/3 | 0_41203EC | 350 | 587 | 640 | 770 | | 1,367 | |
| E 13/7/6 | 0_41205EC | 700 | 1,467 | 1,600 | 1,950 | | 3,300 | |
| E 17/7/4 | 0_41707EC | 520 | 1,013 | 1,100 | 1,300 | | 1,900 | |
| E 19/8/5 | 0_41808EC | 550 | 1,153 | 1,253 | 1,500 | 1,500 | 2,500 | 4,293 |
| E 19/8/10 | 0_41810EC | 1,000 | 2,300 | 2,500 | 3,000 | | 5,000 | 8,600 |
| E 25/10/7 | 0_42510EC | 800 | 1,767 | 1,920 | 2,300 | | 3,700 | 7,660 |
| E 25/13/7 | 0_42513EC | 900 | 1,900 | 2,314 | 2,460 | | 4,000 | |
| E 25/16/6 | 0_42515EC | 540 | 1,153 | 1,253 | 1,500 | | 2,400 | |
| E 25/10/13 | 0_42520EC | 1,600 | 3,533 | 3,840 | 4,600 | | 7,400 | 13,813 |
| E 25/13/11 | 0_42526EC | | 2,800 | 3,512 | 4,068 | 4,068 | 5,951 | |
| E 25/16/13 | 0_42530EC | 1,070 | 2,307 | 2,507 | 3,000 | | 4,800 | 8,213 |
| E 31/15/7 | 0_43007EC | 920 | 2,060 | 2,240 | 2,700 | | 3,800 | 8,200 |
| E 31/13/9 | 0_43009EC | 1,400 | 2,893 | 3,147 | 3,780 | | 5,893 | |
| E 34/14/9 | 0_43515EC | | 2,667 | 2,907 | 3,500 | | 5,813 | 11,414 |
| E 35/21/9 | 0_43520EC | | 1,947 | 2,120 | 2,555 | | 4,240 | |

HOW TO ORDER

OR 43007 EC

Shape code ←
 Ferrite core material ←
 Used for all ferrite types ←
 Approximate length in mm ←
 Approximate height in mm ←
 Geometry code ←

GEOMETRY CODE

EC – E core
 IC – I core

Cores are sold per piece (for sets multiply by 2).
 See page 18 for information on gapped cores.

For an E-core gapped to an A_L value when mated with the standard I-core, add “-EI” to the end of the part number.

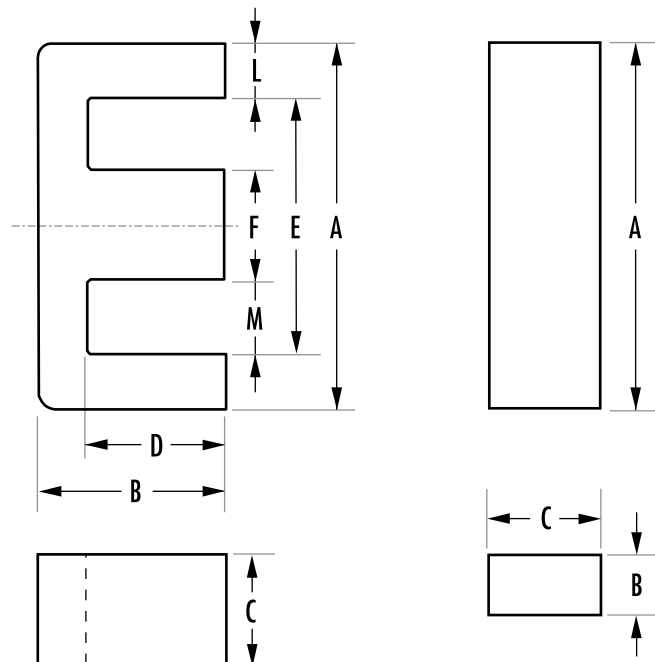

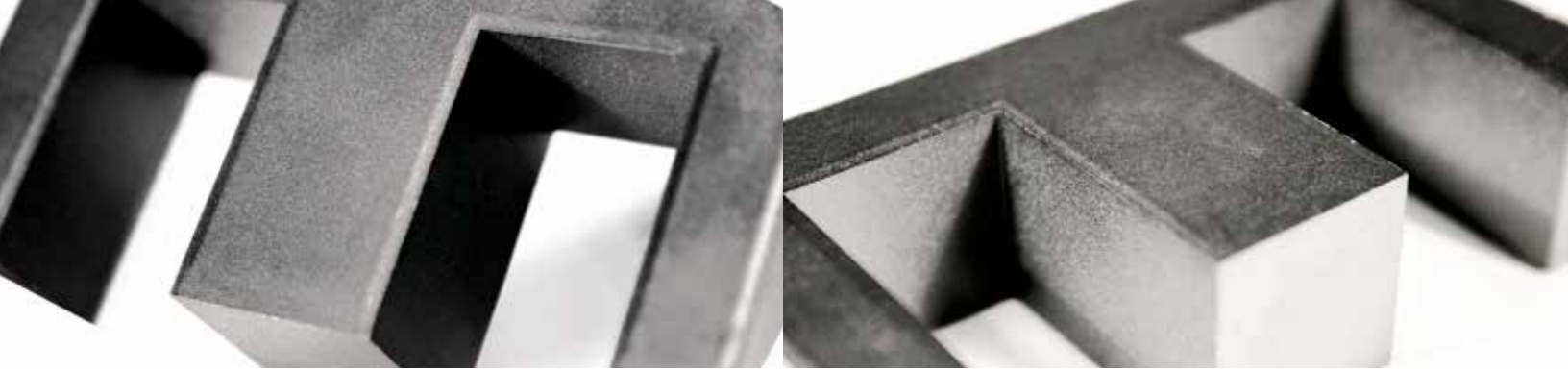

| TYPE/SIZE | ORDERING CODE | MAGNETIC DATA | | | | | | HARDWARE |
|------------|------------------|------------------------|--------------------------------------|--|--------------------------------------|----------------------------|---------------------------|-----------|
| | | I _e (mm) | A _e (mm ²) | A _e min (mm ²) | V _e (mm ³) | WaAc (cm ⁴) | Weight (grams per set) | Bobbins |
| E 9/4/2 | O_40904EC | 15.6 | 5.0 | 3.6 | 78 | 0.002 | 0.7 | |
| E 13/7/3 | O_41203EC | 27.8 | 10.1 | 10.1 | 279 | 0.016 | 1.3 | |
| E 13/7/6 | O_41205EC | 27.7 | 20.2 | 20.0 | 558 | 0.03 | 2.6 | |
| E 17/7/4 | O_41707EC | 30.4 | 16.6 | 12.6 | 505 | 0.03 | 3.0 | |
| E 19/8/5 | O_41808EC | 39.9 | 22.6 | 22.1 | 900 | 0.08 | 4.4 | PCB1808B1 |
| E 19/8/10 | O_41810EC | 40.1 | 45.5 | 45.4 | 1,820 | 0.14 | 8.5 | |
| E 25/10/7 | O_42510EC | 49.0 | 39.5 | 37.0 | 1,930 | 0.16 | 9.5 | O0B251001 |
| E 25/13/7 | O_42513EC | 57.8 | 51.8 | 51.8 | 2,990 | 0.27 | 16 | |
| E 25/16/6 | O_42515EC | 73.5 | 40.1 | 39.7 | 2,950 | 0.56 | 15 | O0B251501 |
| E 25/10/13 | O_42520EC | 48.0 | 78.4 | 76.8 | 3,760 | 0.48 | 19 | PCB2520TA |
| E 25/13/11 | O_42526EC | 57.5 | 78.4 | 76.8 | 4,500 | 0.41 | 36 | |
| E 25/16/13 | O_42530EC | 73.5 | 80.2 | 79.4 | 5,900 | 0.74 | 30 | |
| E 31/15/7 | O_43007EC | 67.0 | 60.0 | 49.0 | 4,000 | 0.50 | 20 | |
| E 31/13/9 | O_43009EC | 61.9 | 83.2 | 83.2 | 5,150 | 0.59 | 26 | PCB3009LA |
| E 34/14/9 | O_43515EC | 69.3 | 80.7 | 80.7 | 5,590 | 0.98 | 28 | PCB3515M1 |
| E 35/21/9 | O_43520EC | 94.3 | 90.6 | 90.5 | 8,540 | 1.68 | 42 | |

Refer to page 62 for additional hardware information.

| TYPE/SIZE | ORDERING CODE | DIMENSIONS (mm) | | | | | | | |
|------------|------------------|-----------------|---------------|--------------|---------------|---------------|--------------|-------------|-------------|
| | | A | B | C | D | E | F | L | M |
| E 9/4/2 | O_40904EC | 9.0 ± 0.4 | 4.06 ± 0.25 | 1.91 ± 0.13 | 2.03 min | 4.85 min | 1.91 ± 0.13 | 1.91 ± 0.25 | 1.57 ± 0.25 |
| E 13/7/3 | O_41203EC | 12.7 ± 0.25 | 5.69 ± 0.18 | 3.18 ± 0.13 | 3.96 min | 9.19 min | 3.18 ± 0.08 | 1.57 nom | 3.05 min |
| E 13/7/6 | O_41205EC | 12.7 ± 0.25 | 5.69 ± 0.18 | 6.4 ± 0.15 | 3.96 min | 9.2 min | 3.2 ± 0.13 | 1.57 ref | 3.05 min |
| E 17/7/4 | O_41707EC | 16.8 ± 0.38 | 7.11 ± 0.18 | 3.56 ± 0.12 | 3.94 min | 10.4 min | 3.56 ± 0.13 | 2.79 nom | 3.63 min |
| E 19/8/5 | O_41808EC | 19.1 ± 0.4 | 8.1 ± 0.13 | 4.75 ± 0.2 | 5.7 ± 0.13 | 14.33 ± 0.33 | 4.75 ± 0.2 | 2.38 nom | 4.79 nom |
| E 19/8/10 | O_41810EC | 19.1 ± 0.4 | 8.1 ± 0.18 | 9.53 ± 0.13 | 5.7 min | 14.0 min | 4.75 ± 0.2 | 2.38 ref | 4.79 ref |
| E 25/10/7 | O_42510EC | 25.4 ± 0.6 | 9.65 ± 0.2 | 6.35 ± 0.25 | 6.4 min | 18.8 min | 6.35 ± 0.25 | 3.3 nom | 6.1 min |
| E 25/13/7 | O_42513EC | 25.0 + 0.8/-0.7 | 12.8 + 0/-0.4 | 7.5 + 0/-0.6 | 8.7 + 0.6/-0 | 17.5 + 0.9/-0 | 7.5 + 0/-0.5 | 3.55 ref | 5.35 ref |
| E 25/16/6 | O_42515EC | 25.4 ± 0.38 | 15.9 ± 0.25 | 6.35 ± 0.25 | 12.6 min | 18.8 min | 6.35 ± 0.13 | 3.12 ± 0.13 | 6.4 ± 0.25 |
| E 25/10/13 | O_42520EC | 25.4 ± 0.6 | 9.65 ± 0.2 | 12.7 ± 0.25 | 6.4 min | 18.8 min | 6.35 ± 0.25 | 3.6 max | 6.1 min |
| E 25/13/11 | O_42526EC | 25.0 + 0.8/-0.7 | 12.8 + 0/-0.5 | 11 + 0/-0.5 | 8.7 + 0.5/-0 | 17.5 + 1/-0 | 7.5 + 0/-0.5 | 3.53 ref | 5.37 ref |
| E 25/16/13 | O_42530EC | 25.4 ± 0.38 | 15.9 ± 0.25 | 12.7 ± 0.25 | 12.6 min | 18.8 min | 6.35 ± 0.13 | 3.12 ± 0.13 | 6.4 ± 0.25 |
| E 31/15/7 | O_43007EC | 30.8 + 0/-1.4 | 15.0 ± 0.2 | 7.3 ± 0/-0.5 | 9.71 + 0.5/-0 | 19.5 + 1/-0 | 7.2 + 0/-0.5 | 5.65 nom | 6.15 nom |
| E 31/13/9 | O_43009EC | 30.95 ± 0.5 | 13.1 ± 0.25 | 9.4 ± 0.3 | 8.5 min | 21.4 min | 9.4 ± 0.13 | 4.29 nom | 6.0 min |
| E 34/14/9 | O_43515EC | 34.3 ± 0.6 | 14.1 ± 0.15 | 9.3 ± 0.25 | 9.8 ± 0.13 | 25.5 min | 9.3 ± 0.2 | 4.7 max | 8.0 min |
| E 35/21/9 | O_43520EC | 34.9 ± 0.38 | 20.6 ± 0.25 | 9.53 ± 0.18 | 15.6 min | 25.1 min | 9.53 ± 0.25 | 4.75 ± 0.25 | 7.95 nom |

E, I Cores

40 mm – 100 mm



| TYPE/SIZE | ORDERING CODE | NOMINAL A_L (mH/1000T) | | | | | |
|-------------|------------------|--------------------------|--------|--------|--------|--------|--------|
| | | R | P | F | T | J | W |
| E 40/17/11 | O_44011EC | 4,000 | 4,347 | 5,200 | | 7,293 | |
| E 42/21/9 | O_44016EC | 2,667 | 2,907 | 3,495 | | 5,647 | |
| E 43/21/15 | O_44020EC | 4,600 | 5,000 | 6,000 | 5,300 | 9,700 | |
| I 43/6/15 | O_44020IC | 6,253 | 6,800 | | | | |
| E 43/21/20 | O_44022EC | 5,533 | 6,013 | 7,600 | 6,950 | 10,613 | |
| E 42/33/20 | O_44033EC | 4,000 | 4,709 | 5,562 | | 8,727 | |
| E 41/17/12 | O_44317EC | 3,900 | 4,240 | 5,900 | | 9,800 | 18,293 |
| E 47/20/16 | O_44721EC | 5,360 | 5,827 | 8,300 | | | |
| E 56/28/21 | O_45528EC | 6,293 | 6,840 | 8,220 | 8,625 | | |
| E 56/28/25 | O_45530EC | 7,520 | 8,173 | 9,800 | 9,860 | 14,920 | |
| E 56/24/19 | O_45724EC | 8,093 | 8,800 | 10,400 | 10,440 | 14,580 | 24,000 |
| E 60/22/16 | O_46016EC | 5,733 | 6,240 | 6,590 | | | |
| E 60/31/22 | O_46022EC | 7,500 | | | | | |
| E 65/32/27 | O_46527EC | 8,600 | 9,200 | | 10,600 | | |
| E 70/33/32 | O_47133EC | 10,800 | 11,600 | 13,400 | 13,330 | | |
| E 72/28/19 | O_47228EC | 5,960 | 6,480 | 7,780 | 7,780 | 11,850 | |
| E 80/38/20 | O_48020EC | 4,673 | 5,080 | 6,000 | 6,730 | | |
| E 100/59/27 | O_49928EC | 6,227 | 6,773 | | 9,010 | | |

HOW TO ORDER

O R 4 7 2 2 8 E C

- Shape code ←
- Ferrite core material ←
- Used for all ferrite types ←
- Approximate length in mm ←
- Approximate height in mm ←
- Geometry code ←

GEOMETRY CODE

EC – E core
IC – I core

Cores are sold per piece (for sets multiply by 2).
See page 18 for information on gapped cores.

For an E-core gapped to an A_L value when mated with the standard I-core, add “-EI” to the end of the part number.

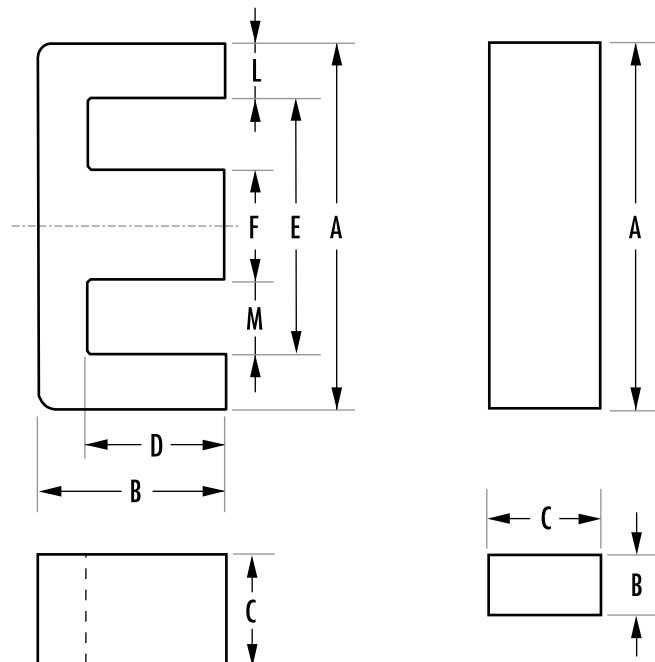

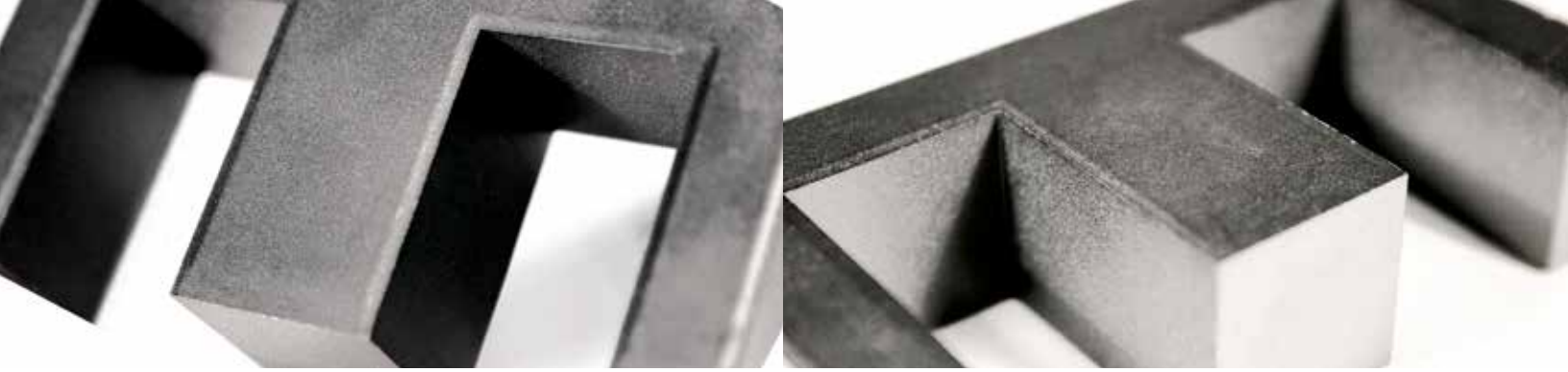

| TYPE/SIZE | ORDERING CODE | MAGNETIC DATA | | | | | | HARDWARE |
|-------------|------------------|------------------------|--------------------------------------|--|--------------------------------------|----------------------------|---------------------------|-----------|
| | | I _e (mm) | A _e (mm ²) | A _e min (mm ²) | V _e (mm ³) | WaAc (cm ⁴) | Weight (grams per set) | Bobbins |
| E 40/17/11 | O_44011EC | 76.7 | 127 | 114 | 9,780 | 1.26 | 49 | |
| E 42/21/9 | O_44016EC | 98.4 | 107 | 106 | 10,500 | 1.65 | 52 | |
| E 43/21/15 | O_44020EC | 97.0 | 178 | 175 | 17,300 | 3.55 | 87 | PCB4020N1 |
| I 43/6/15 | O_44020IC | 67.1 | 177 | 176 | 11,900 | 1.36 | 60 | PCB4020N1 |
| E 43/21/20 | O_44022EC | 97.0 | 233 | 233 | 22,700 | 4.22 | 114 | PCB4022N1 |
| E 42/33/20 | O_44033EC | 145 | 236 | 234 | 34,200 | 6.36 | 164 | |
| E 41/17/12 | O_44317EC | 77.0 | 149 | 142 | 11,500 | 1.88 | 57 | PCB4317M1 |
| E 47/20/16 | O_44721EC | 88.9 | 234 | 226 | 20,800 | 3.3 | 103 | PCB4721M1 |
| E 56/28/21 | O_45528EC | 124 | 353 | 345 | 44,000 | 9.78 | 212 | PCB5528WC |
| E 56/28/25 | O_45530EC | 123 | 420 | 411 | 52,000 | 12.1 | 255 | PCB5530FA |
| E 56/24/19 | O_45724EC | 107 | 337 | 337 | 36,000 | 6.98 | 179 | PCB5724M1 |
| E 60/22/16 | O_46016EC | 110 | 248 | 240 | 27,200 | 5.74 | 135 | |
| E 60/31/22 | O_46022EC | 139 | 402 | 401 | 55,900 | 21.0 | 200 | |
| E 65/32/27 | O_46527EC | 147 | 540 | 530 | 79,000 | 23.5 | 410 | O0B652701 |
| E 70/33/32 | O_47133EC | 149 | 683 | 676 | 102,000 | 23.3 | 495 | |
| E 72/28/19 | O_47228EC | 137 | 368 | 363 | 50,300 | 15.0 | 250 | O0B722801 |
| E 80/38/20 | O_48020EC | 184 | 392 | 392 | 72,300 | 31.6 | 357 | O0B8020B1 |
| E 100/59/27 | O_49928EC | 274 | 738 | 692 | 202,000 | 90.6 | 980 | |

Refer to page 62 for additional hardware information.

| TYPE/SIZE | ORDERING CODE | DIMENSIONS (mm) | | | | | | | |
|-------------|------------------|-----------------|---------------|---------------|---------------|---------------|---------------|--------------|--------------|
| | | A | B | C | D | E | F | L | M |
| E 40/17/11 | O_44011EC | 40.0 ± 0.51 | 17.0 ± 0.31 | 10.69 ± 0.31 | 10.0 min | 27.6 min | 10.7 ± 0.31 | 5.99 ± 0.25 | 8.86 nom |
| E 42/21/9 | O_44016EC | 42.15 ± 0.85 | 21.1 ± 0.2 | 9.0 ± 0.25 | 14.9 min | 29.5 min | 11.95 ± 0.25 | 5.94 ± 0.13 | 8.9 ± 0.25 |
| E 43/21/15 | O_44020EC | 43.0 + 0/-1.7 | 21.0 ± 0.2 | 15.2 + 0/-0.6 | 14.8 + 0.6/-0 | 29.5 + 1.4/-0 | 12.2 + 0/-0.5 | 6.75 nom | 8.65 nom |
| I 43/6/15 | O_44020IC | 43.0 + 0/-1.7 | 5.9 ± 0.2 | 15.2 + 0/-0.6 | | | | | |
| E 43/21/20 | O_44022EC | 43.0 + 0/-1.7 | 21.0 ± 0.2 | 20.0 + 0/-0.8 | 14.8 + 0.6/-0 | 29.5 + 1.4/-0 | 12.2 + 0/-0.5 | 6.75 nom | 8.65 nom |
| E 42/33/20 | O_44033EC | 42.0 + 1/-0.7 | 32.8 + 0/-0.4 | 20.0 + 1/-0.8 | 26.0 + 1/-0 | 29.5 + 1.4/-0 | 12.2 + 0/-0.5 | 5.98 ref | 9.13 ref |
| E 41/17/12 | O_44317EC | 40.6 ± 0.65 | 16.6 ± 0.2 | 12.4 ± 0.3 | 10.4 min | 28.6 min | 12.45 ± 0.25 | 6.33 max | 7.95 min |
| E 47/20/16 | O_44721EC | 46.9 ± 0.8 | 19.6 ± 0.2 | 15.6 ± 0.25 | 12.1 min | 32.4 ± 0.65 | 15.6 ± 0.25 | 7.54 nom | 7.87 min |
| E 56/28/21 | O_45528EC | 56.2 + 0/-2.1 | 27.5 ± 0.3 | 21.0 + 0/-0.8 | 18.5 + 0.8/-0 | 37.5 + 1.5/-0 | 17.2 + 0/-0.5 | 9.35 ref | 10.15 ref |
| E 56/28/25 | O_45530EC | 56.2 + 0/-2.1 | 27.6 ± 0.38 | 24.61 ± 0.38 | 18.5 min | 37.5 min | 17.2 + 0/-0.5 | 9.35 ref | 10.15 ref |
| E 56/24/19 | O_45724EC | 56.1 ± 1 | 23.6 ± 0.25 | 18.8 ± 0.25 | 14.6 ± 0.13 | 38.1 min | 18.8 ± 0.25 | 9.5 nom | 9.03 nom |
| E 60/22/16 | O_46016EC | 59.99 ± 0.78 | 22.3 ± 0.3 | 15.62 ± 0.38 | 13.8 min | 44.0 min | 15.62 ± 0.38 | 7.7 ± 0.25 | 14.49 ± 0.25 |
| E 60/31/22 | O_46022EC | 60.3 ± 0.9 | 30.6 ± 0.3 | 22.3 ± 0.38 | 21.6 ± 0.3 | 42.3 ± 0.78 | 18.1 ± 0.25 | 9.0 ref | 12.1 ref |
| E 65/32/27 | O_46527EC | 65.0 + 1.5/-1.2 | 32.8 + 0/-0.6 | 27.4 + 0/-0.8 | 22.0 + 0.8/-0 | 44.2 + 1.8/-0 | 20.0 + 0/-0.7 | 9.95 ref | 12.72 ref |
| E 70/33/32 | O_47133EC | 70.5 ± 1 | 33.2 + 0/-0.5 | 32.0 + 0/-0.8 | 21.9 + 0.7/-0 | 48.0 + 1.5/-0 | 22.0 + 0/-0.7 | 11.25 nom | 13.0 nom |
| E 72/28/19 | O_47228EC | 72.4 ± 0.76 | 27.9 ± 0.33 | 19.0 ± 0.33 | 17.8 min | 52.6 min | 19.0 ± 0.38 | 9.53 ± 0.38 | 16.9 min |
| E 80/38/20 | O_48020EC | 80.0 ± 1.6 | 38.1 ± 0.3 | 19.8 ± 0.4 | 28.2 ± 0.3 | 59.1 min | 19.8 ± 0.4 | 11.25 nom | 19.45 min |
| E 100/59/27 | O_49928EC | 100.3 ± 2.0 | 59.4 ± 0.47 | 27.5 ± 0.5 | 46.85 ± 0.38 | 72.0 min | 27.5 ± 0.5 | 13.75 ± 0.38 | 22.65 ± 0.5 |

Planar E, I Cores

14 mm – 36 mm

Planar E cores are offered in all of the IEC standard sizes and a number of other sizes. The leg length and window height (B and D dimensions) are adjustable for specific applications without new tooling. This permits the designer to adjust the final core specification to exactly accommodate the planar conductor stack height with no wasted space. Clips and clip slots are available in many cases, which is useful for prototyping. I cores are also offered standard, reducing path length and increasing inductance. Planar cores provide the lowest profile design. E-I planar combinations allow practical face bonding in high volume assembly. The flat back can accommodate a heat sink.

Differential mode inductors, DC/DC, and AC/DC converters are typical applications for planar cores.

| TYPE/SIZE | ORDERING CODE | NOMINAL A_L (mH/1000T) | | | | |
|-----------|------------------|--------------------------|-------|-------|-------|-------|
| | | L | R | P | F | T |
| 14/2.5/5 | O_41425EC | 780 | 1,519 | 1,595 | 1,765 | |
| E 14 C | C_41434EC | 600 | 1,327 | 1,399 | 1,563 | |
| I 14 C | C_41434IC | 780 | 1,504 | 1,580 | 1,749 | |
| E 18 C | C_41805EC | 1,500 | 3,244 | 3,430 | 3,853 | |
| I 18 C | C_41805IC | 1,800 | 3,606 | 3,801 | 4,241 | |
| E 18 | F_41805EC | 1,550 | 3,244 | 3,430 | 3,853 | |
| I 18 | F_41805IC | 1,800 | 3,641 | 3,837 | 4,278 | |
| E 22/4/7 | O_42107EC | 1,350 | 2,920 | 3,173 | 3,810 | |
| I 22/4/7 | O_42107IC | 1,480 | 3,320 | 3,600 | 4,330 | |
| E 22/6/16 | O_42214EC | | 4,600 | | | |
| I 22/2/6 | O_42214IC | | 5,280 | | | |
| E 22 C | C_42216EC | 2,300 | 5,066 | 5,387 | 6,131 | |
| I 22 C | C_42216IC | 2,900 | 6,147 | 6,506 | 7,327 | |
| E 22 | F_42216EC | 2,400 | 5,066 | 5,387 | 6,131 | |
| I 22 | F_42216IC | 2,900 | 6,207 | 6,568 | 7,932 | |
| E 22 | F_42217EC | | 4,400 | | | |
| E 32 C | C_43208EC | 3,200 | 6,521 | 6,918 | 7,834 | 7,690 |
| I 32 C | C_43208IC | 3,700 | 7,321 | 7,745 | 8,711 | 8,520 |
| E 32 | F_43208EC | 3,200 | 6,521 | 6,918 | 7,834 | 7,690 |
| I 32 | F_43208IC | 3,700 | 7,321 | 7,745 | 8,711 | 8,520 |
| E 36/6/18 | O_43618EC | | 6,678 | 7,090 | | |
| I 36/6/18 | O_43618IC | | 7,303 | 7,736 | | |

HOW TO ORDER

C R 4 14 34 EC

Shape code ←
 Ferrite core material ←
 Used for all ferrite types ←
 Approximate length in mm ←
 Approximate width in mm ←
 Geometry code ←

SHAPE CODE

C – Planar core with clip recesses
 F or O – Planar core without clip recesses

GEOMETRY CODE

EC – Planar E core • IC – Planar I core

For clip slot dimensions see individual datasheets.
 Cores are sold per piece (for sets multiply by 2).
 See page 18 for information on gapped cores.
 For an E-core gapped to an A_L value when mated with the standard I-core, add “-EI” to the end of the part number.

E CORE

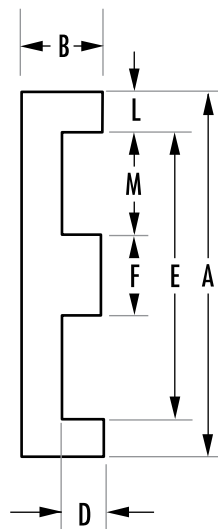

I CORE

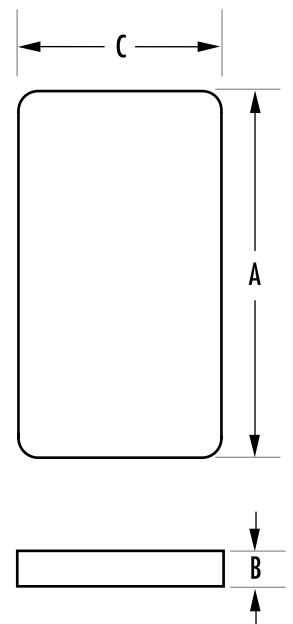



Refer to page 62 for additional hardware information.

| TYPE/SIZE | ORDERING CODE | MAGNETIC DATA | | | | | | HARDWARE | |
|-----------|------------------|---------------|--------------------------|------------------------------|--------------------------|---------------------------|------------------------|-----------|--|
| | | I_e (mm) | A_e (mm ²) | A_e min (mm ²) | V_e (mm ³) | $WaAc$ (cm ⁴) | Weight (grams per set) | Clamps | |
| 14/2.5/5 | O_41425EC | 16.7 | 14.7 | 14.7 | 244 | 0.01 | 1.2 | | |
| E 14 C | C_41434EC | 20.7 | 14.7 | 14.7 | 304 | 0.02 | 1.5 | | |
| I 14 C | C_41434IC | 16.4 | 14.2 | 11.4 | 230 | 0.008 | 1.2 | | |
| E 18 C | C_41805EC | 24.2 | 40.1 | 39.9 | 972 | 0.07 | 4.8 | OOC180520 | |
| I 18 C | C_41805IC | 20.3 | 39.5 | 35.9 | 830 | 0.03 | 4.1 | OOC180520 | |
| E 18 | F_41805EC | 24.2 | 40.1 | 39.9 | 972 | 0.07 | 4.8 | | |
| I 18 | F_41805IC | 20.3 | 40.1 | 39.9 | 813 | 0.03 | 3.9 | | |
| E 22/4/7 | O_42107EC | 25.7 | 37.1 | 36.0 | 960 | 0.06 | 4.2 | | |
| I 22/4/7 | O_42107IC | 22.7 | 35.7 | 33.5 | 809 | 0.03 | 3.9 | | |
| E 22/6/16 | O_42214EC | 32.5 | 78.3 | 77.9 | 2,540 | 0.29 | 6.1 | | |
| I 22/2/6 | O_42214IC | 26.1 | 79.0 | 78.5 | 2,060 | 0.14 | 3.9 | | |
| E 22 C | C_42216EC | 32.3 | 76.0 | 73.1 | 2,451 | 0.27 | 12 | OOC221620 | |
| I 22 C | C_42216IC | 26.1 | 80.4 | 72.5 | 2,100 | 0.14 | 10.4 | OOC221620 | |
| E 22 | F_42216EC | 32.5 | 78.5 | 76.0 | 2,550 | 0.27 | 12.5 | | |
| I 22 | F_42216IC | 25.8 | 80.6 | 80.6 | 2,080 | 0.13 | 10.2 | | |
| E 22 | F_42217EC | 35.1 | 82.1 | 79.0 | 2,880 | 0.36 | 14 | | |
| E 32 C | C_43208EC | 41.4 | 130 | 130 | 5,380 | 0.71 | 26 | OOC320802 | |
| I 32 C | C_43208IC | 35.1 | 130 | 130 | 4,560 | 0.36 | 22 | OOC320802 | |
| E 32 | F_43208EC | 41.4 | 130 | 130 | 5,380 | 0.71 | 26 | | |
| I 32 | F_43208IC | 35.1 | 130 | 130 | 4,560 | 0.36 | 22 | | |
| E 36/6/18 | O_43618EC | 42.4 | 135 | 135 | 5,750 | 0.55 | 28 | | |
| I 36/6/18 | O_43618IC | 37.4 | 135 | 135 | 5,060 | 0.27 | 25 | | |

| TYPE/SIZE | ORDERING CODE | DIMENSIONS (mm) | | | | | | | |
|-----------|------------------|-----------------|-------------|--------------|------------|--------------|-------------|-------------|--------------|
| | | A | B | C | D | E | F | L | M |
| 14/2.5/5 | O_41425EC | 14.0 ± 0.3 | 2.5 ± 0.1 | 5.0 ± 0.1 | 1.0 ± 0.1 | 11.0 ± 0.25 | 3.0 ± 0.1 | 1.5 ref | 4.0 ref |
| E 14 C | C_41434EC | 14.0 ± 0.3 | 3.5 ± 0.1 | 5.0 ± 0.15 | 1.91 min | 10.5 min | 3.0 ± 0.1 | 1.5 ref | 4.0 ref |
| I 14 C | C_41434IC | 14.0 ± 0.3 | 1.8 ± 0.05 | 5.0 ± 0.15 | 1.5 ± 0.1 | 2.5 + 0.2/-0 | | | |
| E 18 C | C_41805EC | 18.0 ± 0.35 | 4.0 ± 0.1 | 10.0 ± 0.2 | 2.0 ± 0.1 | 14 ± 0.3 | 4.0 ± 0.1 | 2.0 ref | 5.0 ref |
| I 18 C | C_41805IC | 18.0 ± 0.35 | 2.4 ± 0.5 | 10.0 ± 0.2 | 2.0 ± 0.1 | 2.5 + 0.2/-0 | | | |
| E 18 | F_41805EC | 18.0 ± 0.35 | 4.0 ± 0.1 | 10.0 ± 0.2 | 2.0 ± 0.1 | 13.7 min | 4.0 ± 0.1 | 2.0 ref | 5.0 ref |
| I 18 | F_41805IC | 18.0 ± 0.41 | 2.39 ± 0.1 | 10.0 ± 0.2 | | | | | |
| E 22/4/7 | O_42107EC | 21.8 ± 0.4 | 3.91 ± 0.8 | 7.8 ± 0.5 | 1.73 ± 0.2 | 16.8 ± 0.3 | 5.0 ± 0.2 | 2.5 ± 0.12 | 5.89 ± 0.25 |
| I 22/4/7 | O_42107IC | 21.8 ± 0.4 | 2.3 ± 0.2 | 7.8 ± 0.3 | | | | | |
| E 22/6/16 | O_42214EC | 21.8 ± 0.4 | 5.7 ± 0.1 | 15.8 ± 0.3 | 3.2 ± 0.1 | 16.8 +/- 0.4 | 5.0 ± 0.1 | 2.6 ref | 5.9 ref |
| I 22/2/6 | O_42214IC | 21.8 ± 0.4 | 2.49 ± 0.13 | 15.8 ± 0.3 | | | | | |
| E 22 C | C_42216EC | 21.8 ± 0.4 | 5.7 ± 0.1 | 15.8 ± 0.3 | 3.05 min | 16.1 min | 5.0 ± 0.1 | 2.5 ref | 5.9 ref |
| I 22 C | C_42216IC | 21.8 ± 0.4 | 2.9 ± 0.05 | 15.8 ± 0.3 | 2.5 ± 0.1 | 2.9 + 0.2/-0 | | | |
| E 22 | F_42216EC | 21.8 ± 0.4 | 5.72 ± 0.1 | 15.8 ± 0.3 | 3.05 min | 16.1 min | 5.0 ± 0.1 | 2.5 ref | 5.9 ref |
| I 22 | F_42216IC | 21.8 ± 0.4 | 2.95 ± 0.1 | 15.8 ± 0.3 | | | | | |
| E 22 | F_42217EC | 21.6 ± 0.25 | 6.55 ± 0.08 | 15.9 ± 0.25 | 3.9 ± 0.1 | 16.3 ± 0.3 | 5.0 ± 0.15 | 2.65 ref | 5.65 ref |
| E 32 C | C_43208EC | 31.75 ± 0.64 | 6.35 ± 0.13 | 20.32 ± 0.41 | 3.18 ± 0.2 | 24.9 min | 6.35 ± 0.13 | 3.18 ref | 9.27 ref |
| I 32 C | C_43208IC | 31.75 ± 0.64 | 3.18 ± 0.13 | 20.32 ± 0.41 | | | | | |
| E 32 | F_43208EC | 31.75 ± 0.64 | 6.35 ± 0.13 | 20.32 ± 0.41 | 3.18 ± 0.2 | 24.9 min | 6.35 ± 0.13 | 3.18 ref | 9.27 ref |
| I 32 | F_43208IC | 31.75 ± 0.64 | 3.18 ± 0.13 | 20.32 ± 0.41 | | | | | |
| E 36/6/18 | O_43618EC | 35.56 ± 0.5 | 6.35 ± 0.13 | 17.8 ± 0.4 | 2.41 min | 27.2 min | 7.62 ± 0.18 | 3.81 ± 0.13 | 10.16 ± 0.25 |
| I 36/6/18 | O_43618IC | 35.56 ± 0.5 | 3.68 ± 0.3 | 17.8 ± 0.4 | | | | | |

Planar E, I Cores

38 mm – 102 mm



| TYPE/SIZE | ORDERING CODE | NOMINAL A_L (mH/1000T) | | | | |
|-----------|------------------|--------------------------|--------|--------|--------|-------|
| | | L | R | P | F | J |
| E 38 | F_43808EC | 3,880 | 7,618 | 8,354 | 9,490 | |
| I 38 | F_43808IC | 4,600 | 9,028 | 9,566 | 10,801 | |
| E 38 | F_43809EC | | 7,300 | | | |
| E 40/8/10 | O_44008EC | | 4,233 | 4,504 | 5,134 | 7,130 |
| I 40/4/10 | O_44008IC | | 4,744 | 5,035 | 5,706 | 8,026 |
| E 43/8/28 | O_44308EC | | 8,598 | 9,150 | 10,432 | |
| I 43/4/28 | O_44308IC | | 9,541 | 10,130 | 11,849 | |
| E 43 | F_44310EC | | 8,266 | 8,803 | 10,057 | |
| I 43 | F_44310IC | | 9,541 | 10,130 | 11,489 | |
| E 58 C | C_45810EC | | 8,498 | 9,073 | 10,427 | |
| I 58 C | C_45810IC | | 9,821 | 10,457 | 11,941 | |
| E 58 | F_45810EC | | 8,498 | 9,073 | 10,427 | |
| I 58 | F_45810IC | | 9,821 | 10,457 | 11,941 | |
| E 64 C | C_46410EC | | 14,618 | 15,599 | 17,901 | |
| E 64 | F_46410EC | | 14,618 | 15,599 | 17,901 | |
| I 64 | F_46410IC | | 16,192 | 17,245 | 19,699 | |
| E 102 | O_49938EC | | 9,292 | 9,997 | 11,697 | |

HOW TO ORDER

C R 4 64 10 EC

Shape code ←
 Ferrite core material ←
 Used for all ferrite types ←
 Approximate length in mm ←
 Approximate width in mm ←
 Geometry code ←

SHAPE CODE

C – Planar core with clip recesses
 F or O – Planar core without clip recesses

GEOMETRY CODE

EC – Planar E core
 IC – Planar I core

For clip slot dimensions see individual datasheets.
 Cores are sold per piece (for sets multiply by 2).
 See page 18 for information on gapped cores.
 For an E-core gapped to an A_L value when mated with the standard I-core, add “-EI” to the end of the part number.

E CORE

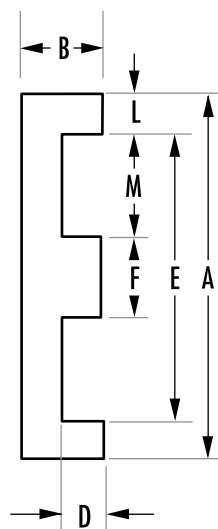

I CORE

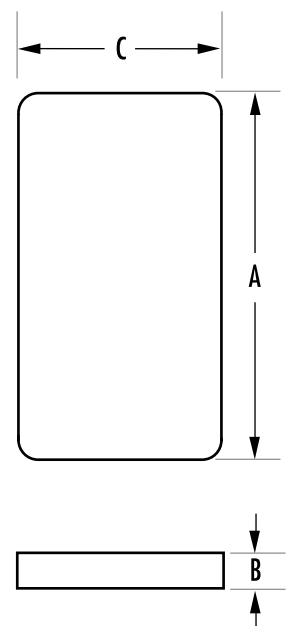



| TYPE/SIZE | ORDERING CODE | MAGNETIC DATA | | | | | | HARDWARE |
|-----------|------------------|---------------|--------------------------|------------------------------|--------------------------|---------------------------|------------------------|-----------|
| | | I_e (mm) | A_e (mm ²) | A_e min (mm ²) | V_e (mm ³) | $WaAc$ (cm ⁴) | Weight (grams per set) | Clamps |
| E 38 | F_43808EC | 52.4 | 194 | 194 | 10,200 | 1.88 | 51 | |
| I 38 | F_43808IC | 43.7 | 194 | 194 | 8,460 | 0.94 | 42 | |
| E 38 | F_43809EC | 57.8 | 192 | 191 | 11,100 | 2.48 | 55 | |
| E 40/8/10 | O_44008EC | 51.9 | 101 | 95.1 | 5,220 | 0.77 | 26 | |
| I 40/4/10 | O_44008IC | 43.8 | 99.5 | 95.1 | 4,360 | 0.38 | 21 | |
| E 43/8/28 | O_44308EC | 57.5 | 227 | 227 | 13,100 | 2.52 | 64 | |
| I 43/4/28 | O_44308IC | 48.6 | 227 | 227 | 11,000 | 1.27 | 54 | |
| E 43 | F_44310EC | 61.1 | 229 | 229 | 13,900 | 3.18 | 71 | |
| I 43 | F_44310IC | 50.4 | 229 | 229 | 11,500 | 1.59 | 58 | |
| E 58 C | C_45810EC | 80.6 | 308 | 308 | 24,600 | 8.16 | 119 | 00C581001 |
| I 58 C | C_45810IC | 67.7 | 310 | 310 | 20,800 | 4.09 | 101 | 00C581002 |
| E 58 | F_45810EC | 80.6 | 308 | 308 | 24,600 | 8.16 | 119 | |
| I 58 | F_45810IC | 68.3 | 310 | 310 | 20,829 | 4.09 | 101 | |
| E 64 C | C_46410EC | 80.2 | 516 | 516 | 41,400 | 11.10 | 195 | 00C641001 |
| E 64 | F_46410EC | 80.2 | 516 | 516 | 41,400 | 11.10 | 200 | |
| I 64 | F_46410IC | 69.6 | 511 | 511 | 35,539 | 5.52 | 172 | |
| E 102 | O_49938EC | 148 | 540 | 525 | 79,800 | 50.5 | 400 | |

Refer to page 62 for additional hardware information.

| TYPE/SIZE | ORDERING CODE | DIMENSIONS (mm) | | | | | | | |
|-----------|------------------|-----------------|-------------|-------------|-------------|-------------|--------------|-------------|-------------|
| | | A | B | C | D | E | F | L | M |
| E 38 | F_43808EC | 38.1 ± 0.76 | 8.26 ± 0.13 | 25.4 ± 0.51 | 4.45 ± 0.13 | 30.23 min | 7.62 ± 0.15 | 3.81 | 11.43 |
| I 38 | F_43808IC | 38.1 ± 0.76 | 3.81 ± 0.13 | 25.4 ± 0.51 | | | | | |
| E 38 | F_43809EC | 38.1 ± 0.76 | 9.53 ± 0.13 | 25.4 ± 0.51 | 5.72 ± 0.13 | 30.23 min | 7.62 ± 0.15 | 3.81 | 11.43 |
| E 40/8/10 | O_44008EC | 40.65 ± 0.5 | 8.51 ± 0.25 | 10.7 ± 0.25 | 4.06 ± 0.25 | 30.45 ± 0.3 | 10.15 ± 0.15 | 5.1 ref | 10.15 ref |
| I 40/4/10 | O_44008IC | 40.64 ± 0.5 | 4.45 ± 0.25 | 10.7 ± 0.25 | | | | | |
| E 43/8/28 | O_44308EC | 43.2 ± 0.5 | 8.51 ± 0.25 | 27.9 ± 0.38 | 4.19 min | 34.4 min | 8.13 ± 0.13 | 4.2 nom | 13.46 nom |
| I 43/4/28 | O_44308IC | 43.2 ± 0.9 | 4.1 ± 0.13 | 27.9 ± 0.6 | | | | | |
| E 43 | F_44310EC | 43.2 ± 0.9 | 9.50 ± 0.13 | 27.9 ± 0.6 | 5.4 ± 0.13 | 34.7 min | 8.1 ± 0.2 | 4.7 max | 13.2 min |
| I 43 | F_44310IC | 43.2 ± 0.9 | 4.1 ± 0.13 | 27.9 ± 0.6 | | | | | |
| E 58 C | C_45810EC | 58.42 ± 1.2 | 10.54 ± 0.2 | 38.1 ± 0.8 | 6.35 min | 50.0 min | 8.1 ± 0.2 | 3.7 ref | 21.4 ref |
| I 58 C | C_45810IC | 58.42 ± 1.2 | 4.06 ± 0.13 | 38.1 ± 0.8 | | | | | |
| E 58 | F_45810EC | 58.42 ± 1.2 | 10.54 ± 0.2 | 38.1 ± 0.8 | 6.35 min | 50.0 min | 8.1 ± 0.2 | 3.7 ref | 21.4 ref |
| I 58 | F_45810IC | 58.42 ± 1.2 | 4.06 ± 0.13 | 38.1 ± 0.8 | | | | | |
| E 64 C | C_46410EC | 64.0 ± 0.76 | 10.2 ± 0.1 | 50.8 ± 0.81 | 5.03 min | 53.16 min | 10.16 ± 0.18 | 5.08 ± 0.12 | 21.8 ± 0.25 |
| I 64 C | C_46410IC | 64.0 ± 1.27 | 5.08 ± 0.13 | 50.8 ± 1.02 | | | | | |
| E 64 | F_46410EC | 64.0 ± 0.76 | 10.2 ± 0.1 | 50.8 ± 0.81 | 5.03 min | 53.16 min | 10.16 ± 0.18 | 5.08 ± 0.12 | 21.8 ± 0.25 |
| I 64 | F_46410IC | 64.0 ± 1.27 | 5.08 ± 0.13 | 50.8 ± 1.02 | | | | | |
| E 102 | O_49938EC | 102.0 ± 1.0 | 20.3 ± 0.25 | 37.5 ± 0.4 | 13.3 ± 0.25 | 86.0 ± 1.0 | 14.0 ± 0.25 | 8.0 ref | 36.0 ref |

ER Cores

ER cores are a cross between planar E cores and pot cores. The round center post of the ER core offers minimal winding resistance. In addition, they offer better space utilization and shielding than with rectangular center leg planar cores. When compared with non-planar cores, ERs offer minimal height and better thermal performance. E/I combinations facilitate economical assembly.

Typical applications of ER cores include differential mode inductors and power transformers.

| TYPE/SIZE | ORDERING CODE | NOMINAL A_L (mH/1000T) | | | |
|--------------|------------------|--------------------------|-------|-------|-------|
| | | L | R | P | F |
| ER 9/5 | O_40906EC | 525 | 973 | 1,053 | 1,270 |
| ER 11/6 | O_41126EC | 725 | 1,400 | 1,690 | 1,780 |
| ER 12.5/8.5 | O_41308EC | 950 | 1,700 | 1,800 | 1,950 |
| I 12.5/8.5 | O_41308IC | 1,000 | 1,800 | 1,900 | 2,000 |
| ER 14.5/6 | O_41426EC | 850 | 1,600 | 1,700 | 1,850 |
| ER 18/3/10 | O_41826EC | 1,300 | 2,623 | 2,770 | 3,104 |
| ER 20/7/14 | C_42014EC | 1,600 | 3,788 | 4,026 | 4,575 |
| I 20/7/14 | C_42014IC | 2,150 | 4,500 | 4,900 | 5,500 |
| ER 20/7/14 | F_42014EC | 1,600 | 3,788 | 4,026 | 4,575 |
| I 20/7/14 | F_42014IC | 2,150 | 4,479 | 4,740 | 5,338 |
| ER 23/3/12 | O_42313EC | 1,850 | 3,800 | 4,030 | 4,540 |
| ER 25/5.5/18 | O_42517EC | 2,650 | 5,700 | 6,050 | 6,900 |
| I 25/2/18 | O_42517IC | 3,300 | 7,021 | 7,447 | 8,427 |
| ER 25/8/18 | O_42521EC | 2,300 | 5,440 | 5,801 | 6,649 |
| ER 30/8/20 | O_43021EC | 2,400 | 5,465 | 5,841 | 6,729 |
| I 30/2.5/20 | O_43021IC | 3,200 | 6,550 | 7,784 | 8,850 |
| ER 32/6/25 | O_43225EC | | 6,950 | 7,350 | 8,200 |

HOW TO ORDER

O R 4 0 9 0 6 E C

Shape code ←
 Ferrite core material ←
 Used for all ferrite types ←
 Approximate length in mm ←
 Approximate depth in mm ←
 Geometry code ←

SHAPE CODE

C – ER core with clip recesses
 F or O – ER core without clip recesses

GEOMETRY CODE

EC – ER core
 IC – I core

For clip slot dimensions see individual datasheets.
 ER cores are sold per piece (for sets multiply by 2).
 See page 18 for information on gapped cores.
 For an E-core gapped to an A_L value when mated with the standard I-core, add “-EI” to the end of the part number.

ER CORE

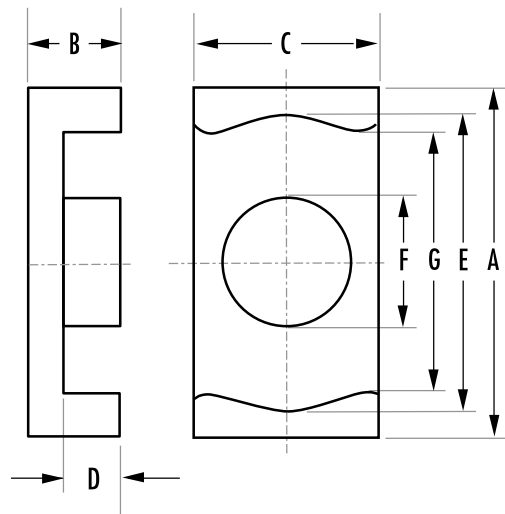

I CORE

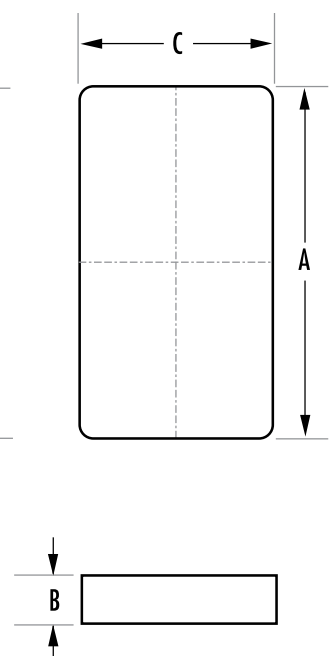



| | | MAGNETIC DATA | | | | | | HARDWARE |
|--------------|------------------|------------------------|--------------------------------------|--|--------------------------------------|----------------------------|---------------------------|-----------|
| TYPE/SIZE | ORDERING CODE | I _e (mm) | A _e (mm ²) | A _e min (mm ²) | V _e (mm ³) | WaAc (cm ⁴) | Weight (grams per set) | Bobbins |
| ER 9/5 | O_40906EC | 14.2 | 8.47 | 7.6 | 120 | 0.003 | 1 | SMB09068A |
| ER 11/6 | O_41126EC | 14.7 | 11.9 | 10.3 | 174 | 0.004 | 1 | |
| ER 12.5/8.5 | O_41308EC | 17.5 | 19.9 | 19.2 | 348 | 0.011 | 2 | |
| I 12.5/8.5 | O_41308IC | 15.9 | 19.8 | 19.2 | 315 | 0.006 | 1 | |
| ER 14.5/6 | O_41426EC | 19.0 | 17.6 | 17.3 | 333 | 0.011 | 2 | |
| ER 18/3/10 | O_41826EC | 22.1 | 30.2 | 30.1 | 667 | 0.025 | 3 | |
| ER 20/7/14 | C_42014EC | 33.2 | 59.0 | 55.0 | 1,960 | 0.142 | 10.2 | |
| I 20/7/14 | C_42014IC | 25.1 | 59.8 | 55.0 | 1,500 | 0.072 | 8.0 | |
| ER 20/7/14 | F_42014EC | 33.2 | 59.0 | 55.0 | 1,960 | 0.142 | 10.1 | |
| I 20/7/14 | F_42014IC | 25.5 | 57.3 | 52.5 | 1,460 | 0.069 | 8.0 | |
| ER 23/3/12 | O_42313EC | 26.6 | 50.2 | 50.0 | 1,340 | 0.055 | 6.4 | |
| ER 25/5.5/18 | O_42517EC | 33.8 | 91.8 | 86.4 | 3,100 | 0.151 | 16.4 | |
| I 25/2/18 | O_42517IC | 26.4 | 89.7 | 82.8 | 2,370 | 0.076 | 13.1 | |
| ER 25/8/18 | O_42521EC | 41.4 | 100 | 95.0 | 4,145 | 0.324 | 22.0 | |
| ER 30/8/20 | O_43021EC | 46.0 | 108 | 95.0 | 4,970 | 0.488 | 26.4 | |
| I 30/2.5/20 | O_43021IC | 36.2 | 108 | 95.0 | 3,910 | 0.244 | 20.8 | |
| ER 32/6/25 | O_43225EC | 38.2 | 141 | 121 | 5,400 | 0.328 | 27.5 | |

Refer to page 62 for additional hardware information.

| | | DIMENSIONS (mm) | | | | | | |
|--------------|------------------|------------------|-------------|-------------|--------------|--------------|---------------|--------------|
| TYPE/SIZE | ORDERING CODE | A | B | C | D | E | F | G |
| ER 9/5 | O_40906EC | 9.5 +0/-0.3 | 2.45 ± 0.05 | 5.0 +0/-0.2 | 1.6 +0.15/-0 | 7.5 +0.4/-0 | 3.5 +0/-0.2 | 7.1 +0.35/-0 |
| ER 11/6 | O_41126EC | 11.0 +0/-0.35 | 2.45 ± 0.05 | 6.0 +0/-0.2 | 1.5 +0.15/-0 | 8.7 +0.3/-0 | 4.25 +0/-0.25 | 8.0 +0/-0.25 |
| ER 12.5/8.5 | O_41308EC | 12.8 ± 0.3 | 2.85 ± 0.8 | 8.7 ± 0.25 | 1.75 ± 0.13 | 11.2 ± 0.3 | 5.0 ± 0.15 | 9.05 ± 0.3 |
| I 12.5/8.5 | O_41308IC | 12.8 ± 0.3 | 1.1 ± 0.1 | 8.7 ± 0.25 | | | | |
| ER 14.5/6 | O_41426EC | 14.7 +0/-0.4 | 2.95 ± 0.5 | 6.8 +0/-0.2 | 1.55 +0.2/-0 | 11.6 +0.4/-0 | 4.8 +0/-0.2 | |
| ER 18/3/10 | O_41826EC | 18.0 ± 0.35 | 3.15 ± 0.1 | 9.7 ± 0.2 | 1.6 ± 0.1 | 15.6 ± 0.3 | 6.2 ± 0.15 | 13.5 min |
| ER 20/7/14 | C_42014EC | 20.0 ± 0.35 | 6.8 ± 0.1 | 14.0 ± 0.3 | 4.6 ± 0.15 | 18 ± 0.35 | 8.8 ± 0.15 | 12.86 ± 0.35 |
| I 20/7/14 | C_42014IC | 20.0 ± 0.35 | 2.3 ± 0.05 | 14.0 ± 0.3 | 1.9 ± 0.1 | 3.0 ± 0.1 | | |
| ER 20/7/14 | F_42014EC | 20.0 ± 0.35 | 6.8 ± 0.1 | 14.0 ± 0.3 | 4.6 ± 0.15 | 18.0 ± 0.35 | 8.8 ± 0.15 | 12.86 ± 0.35 |
| I 20/7/14 | F_42014IC | 20.0 ± 0.35 | 1.9 ± 0.05 | 14.0 ± 0.3 | | | | |
| ER 23/3/12 | O_42313EC | 23.2 ± 0.45 | 3.6 ± 0.1 | 12.5 ± 0.25 | 1.6 ± 0.1 | 20.2 ± 0.4 | 8.0 ± 0.2 | 17.5 min |
| ER 25/5.5/18 | O_42517EC | 25.0 ± 0.4 | 5.6 ± 0.1 | 18.0 ± 0.3 | 2.75 ± 0.15 | 22.0 ± 0.4 | 11.0 ± 0.2 | 15.2 ± 0.7 |
| I 25/2/18 | O_42517IC | 25.0 ± 0.4 | 2.3 ± 0.05 | 18.0 ± 0.3 | | | | |
| ER 25/8/18 | O_42521EC | 25.0 ± 0.4 | 8.0 ± 0.1 | 18.0 ± 0.3 | 5.15 ± 0.15 | 22.0 ± 0.4 | 11.0 ± 0.2 | 15.2 ± 0.7 |
| ER 30/8/20 | O_43021EC | 30.0 ± 0.4 | 8.0 ± 0.15 | 20.0 ± 0.3 | 5.3 ± 0.2 | 26.0 ± 0.4 | 11.0 ± 0.2 | 19.45 ± 0.4 |
| I 30/2.5/20 | O_43021IC | 30.0 ± 0.4 | 2.7 ± 0.1 | 20.0 ± 0.3 | | | | |
| ER 32/6/25 | O_43225EC | 32.1 +0.55/-0.45 | 6.0 ± 0.13 | 25.4 ± 0.4 | 2.9 +0/-0.25 | 27.2 ± 0.4 | 12.4 ± 0.15 | 27.2 ± 0.4 |

U, I Cores

U cores are ideal for many power transformer applications. The long legs support low leakage inductance designs and facilitate superior voltage isolation. U/I combinations provide for economical assembly.

| TYPE/SIZE | ORDERING CODE | NOMINAL A_L (mH/1000T) | | | | | |
|-------------|------------------|--------------------------|-------|-------|-------|--------|-------|
| | | L | R | P | F | J | W |
| U 11/4/6 | 0_41106UC | | 860 | 914 | 1,010 | 1,662 | |
| I 11/2/6 | 0_41106IC | | 960 | 1,020 | 1,150 | 1,687 | |
| U 22/21/6 | 0_42220UC | | 893 | 973 | 1,360 | 2,107 | 3,429 |
| U 25/13/13 | 0_42512UC | | 1,907 | 2,067 | 2,480 | 4,400 | |
| U 25/16/6 | 0_42515UC | | 1,107 | 1,333 | 1,600 | 2,507 | |
| I 25/6/6 | 0_42516IC | 660 | 1,480 | 1,650 | 1,770 | 2,907 | |
| U 25/16/12 | 0_42530UC | | 2,093 | 2,280 | 2,740 | 4,860 | |
| U 93/76/16 | 0_49316UC | | 3,450 | 3,730 | 4,110 | 8,100 | |
| I 93/28/16 | 0_49316IC | | 4,600 | 4,960 | 5,840 | 10,500 | |
| U 93/76/30 | 0_49330UC | | | 7,219 | | | |
| U 93/76/32 | 0_49332UC | | | 7,700 | | | |
| U 126/91/20 | 0_49920UC | | 3,000 | 3,572 | 4,265 | 6,967 | |
| U 102/57/25 | 0_49925UC | | 4,533 | 5,500 | 6,500 | | |
| I 102/25/25 | 0_49925IC | | 5,707 | 6,200 | 7,440 | | |

HOW TO ORDER

O F 4 22 20 UC

Shape code ←
 Ferrite core material ←
 Used for all ferrite types ←
 Approximate length in mm ←
 Approximate width in mm ←
 Geometry code ←

GEOMETRY CODE

UC – U core
 IC – I core

U and I cores are sold per piece (for sets multiply by 2).

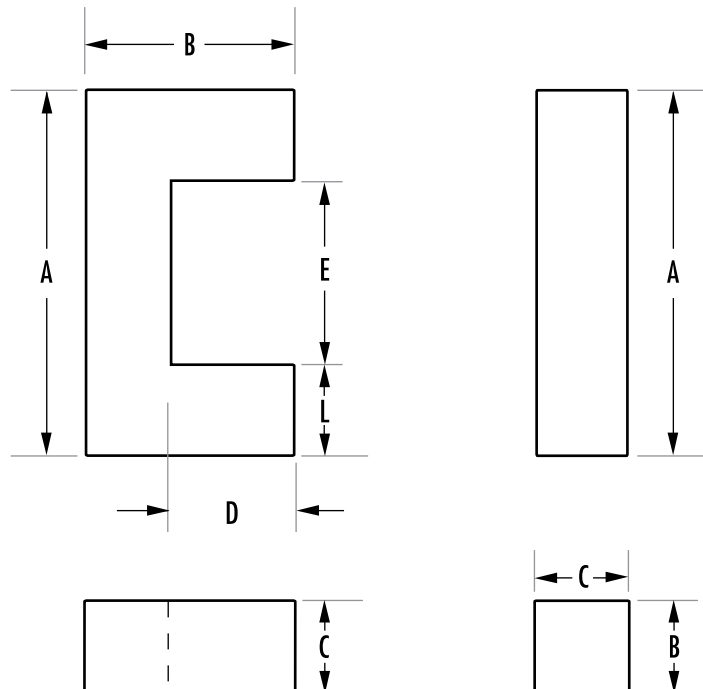

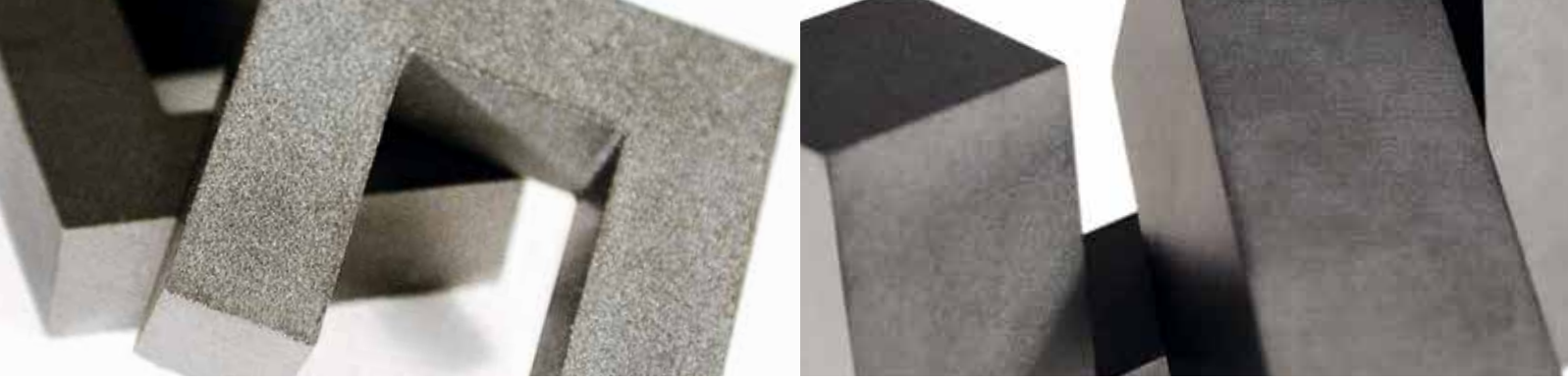

| TYPE/SIZE | ORDERING CODE | MAGNETIC DATA | | | | | | HARDWARE |
|-------------|------------------|------------------------|--------------------------------------|--|--------------------------------------|----------------------------|---------------------------|----------|
| | | I _e (mm) | A _e (mm ²) | A _e min (mm ²) | V _e (mm ³) | WaAc (cm ⁴) | Weight (grams per set) | Bobbins |
| U 11/4/6 | 0_41106UC | 29.2 | 12 | 11.5 | 350 | 0.02 | 1.8 | |
| I 11/2/6 | 0_41106IC | 24.6 | 11.5 | 11.5 | 283 | 0.01 | 1.5 | |
| U 22/21/6 | 0_42220UC | 95.8 | 39.7 | 39.7 | 4,130 | 0.63 | 19 | |
| U 25/13/13 | 0_42512UC | 68.9 | 80.0 | 80.0 | 4,170 | 0.78 | 29 | |
| U 25/16/6 | 0_42515UC | 83.4 | 40.4 | 40.4 | 3,370 | 0.57 | 17 | |
| I 25/6/6 | 0_42516IC | 64.3 | 40.3 | 40.3 | 2,590 | 0.32 | 13 | |
| U 25/16/12 | 0_42530UC | 83.4 | 80.8 | 80.8 | 6,740 | 1.13 | 34 | |
| U 93/76/16 | 0_49316UC | 353 | 452 | 452 | 160,000 | 91.4 | 800 | |
| I 93/28/16 | 0_49316IC | 257 | 450 | 450 | 115,000 | 45.8 | 600 | |
| U 93/76/30 | 0_49330UC | 354 | 840 | 840 | 297,000 | 173 | 1,490 | |
| U 93/76/32 | 0_49332UC | 353 | 905 | 896 | 319,000 | 185 | 1,600 | |
| U 126/91/20 | 0_49920UC | 480 | 560 | 560 | 268,800 | 286 | 1,360 | |
| U 102/57/25 | 0_49925UC | 308 | 645 | 645 | 199,000 | 121 | 988 | |
| I 102/25/25 | 0_49925IC | 245 | 645 | 645 | 158,000 | 60.7 | 784 | |

Refer to page 62 for additional hardware information.

| TYPE/SIZE | ORDERING CODE | DIMENSIONS (mm) | | | | | |
|-------------|------------------|-------------------|-------------|-------------|-------------|------------|-------------|
| | | A | B | C | D | E | L |
| U 11/4/6 | 0_41106UC | 10.85 ± 0.2 | 4.19 ± 0.13 | 6.3 ± 0.13 | 2.24 ± 0.13 | 7.19 ± 0.2 | 1.83 ± 0.13 |
| I 11/2/6 | 0_41106IC | 10.8 ± 0.2 | 1.83 ± 0.12 | 6.3 ± 0.13 | | | |
| U 22/21/6 | 0_42220UC | 22.1 ± 0.38 | 20.6 ± 0.38 | 6.27 ± 0.18 | 13.98 min | 9.5 ± 0.38 | 6.27 ± 0.18 |
| U 25/13/13 | 0_42512UC | 25.4 ± 0.5 | 12.9 ± 0.4 | 12.7 ± 0.4 | 6.35 min | 12.8 ref | 6.3 ± 0.13 |
| U 25/16/6 | 0_42515UC | 25.4 ± 0.51 | 15.9 ref | 6.35 ± 0.12 | 9.27 min | 12.7 ref | 6.45 ± 0.15 |
| I 25/6/6 | 0_42516IC | 25.4 + 0.64/-0.51 | 6.35 ± 0.13 | 6.35 ± 0.13 | | | |
| U 25/16/12 | 0_42530UC | 25.4 ± 0.51 | 15.9 ref | 12.7 ± 0.25 | 9.27 min | 12.7 ref | 6.45 ± 0.15 |
| U 93/76/16 | 0_49316UC | 93.0 ± 1.8 | 76.0 ± 0.5 | 16.0 ± 0.6 | 48.0 ± 0.9 | 36.2 ± 1.2 | 28.4 ref |
| I 93/28/16 | 0_49316IC | 93.0 ± 1.8 | 27.5 ± 0.5 | 16.0 ± 0.6 | | | |
| U 93/76/30 | 0_49330UC | 93.0 ± 1.8 | 76.0 ± 0.5 | 30.0 ± 0.6 | 48.0 ± 0.9 | 36.2 ± 1.2 | 28.4 ref |
| U 93/76/32 | 0_49332UC | 93.0 ± 1.8 | 76.0 ± 0.5 | 32.0 ± 0.6 | 48.0 ± 0.9 | 36.2 ± 1.2 | 28.4 ref |
| U 126/91/20 | 0_49920UC | 126.0 ± 4.0 | 91.0 ± 1.0 | 20.0 ± 0.6 | 63.0 ± 2.0 | 70.0 ± 2.0 | 28.0 ref |
| U 102/57/25 | 0_49925UC | 101.6 ± 1.5 | 57.1 ± 0.4 | 25.4 ± 0.6 | 31.7 ± 0.75 | 50.8 ± 1 | 25.4 ± 0.8 |
| I 102/25/25 | 0_49925IC | 101.6 ± 1.5 | 25.4 ± 0.4 | 25.4 ± 0.6 | | | |

UR Cores

UR cores are an excellent choice for high current designs and conditions where vibration occurs. The open window area accommodates large conductors. Holes through the center or grooves on the outer legs of the core provide a method to secure the core to the PCB with mounting hardware.

Typical applications include welding output transformers, audio amplifiers, traction, and other high-voltage power transformers.

| TYPE/SIZE | ORDERING CODE | NOMINAL A_L (mH/1000T) | | |
|-------------|------------------|--------------------------|-------|-------|
| | | R | P | F |
| UR 41/21/11 | 0_44119UC | 1,627 | 1,773 | 2,130 |
| UR 41/21 | 0_44121UC | 1,880 | 2,047 | 2,465 |
| UR 41/25 | 0_44125UC | 1,600 | 1,747 | 2,105 |
| UR 41/30 | 0_44130UC | 1,400 | 1,520 | 1,830 |
| UR 57 | 0_45716UC | 2,600 | 3,061 | 3,622 |
| UR 59 | 0_45917UC | 3,027 | 3,274 | 3,881 |
| UR 64* | 0_46420UC | 3,787 | 4,098 | 4,864 |

HOW TO ORDER

OP 44125 UC

- Shape code ←
- Ferrite core material ←
- Used for all ferrite types ←
- Approximate length in mm ←
- Approximate depth in mm ←
- Geometry code ←

UR cores are sold per piece (for sets multiply by 2).
 *For UR 64 size, refer to datasheets for differences in geometry.

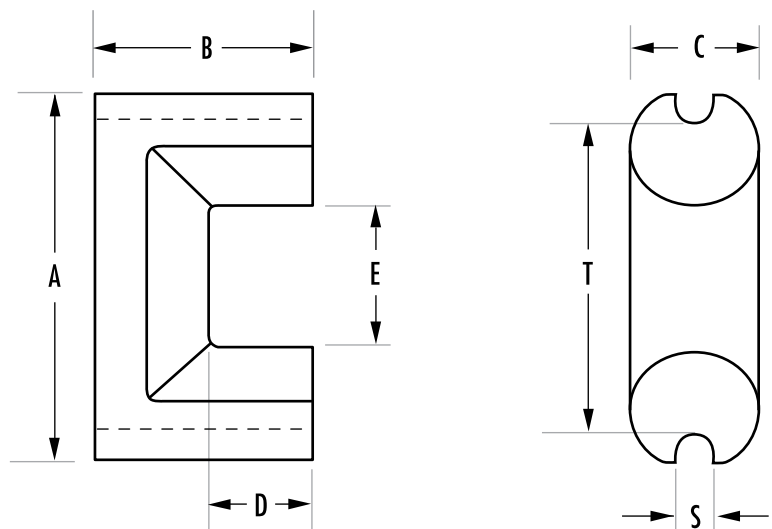



| TYPE/SIZE | ORDERING CODE | MAGNETIC DATA | | | | | | HARDWARE |
|-------------|------------------|------------------------|--------------------------------------|--|--------------------------------------|----------------------------|---------------------------|-----------|
| | | I _e (mm) | A _e (mm ²) | A _e min (mm ²) | V _e (mm ³) | WaAc (cm ⁴) | Weight (grams per set) | Bobbins |
| UR 41/21/11 | 0_44119UC | 121.2 | 91.1 | 80.5 | 11,000 | 2.75 | 54 | 00B411901 |
| UR 41/21 | 0_44121UC | 113 | 104 | 84.0 | 11,800 | 2.81 | 55 | |
| UR 41/25 | 0_44125UC | 134.4 | 113.1 | 105.4 | 15,196 | 4.0 | 64 | |
| UR 41/30 | 0_44130UC | 154.8 | 112.1 | 105.4 | 17,346 | 5.25 | 75 | |
| UR 57 | 0_45716UC | 163 | 171 | 171 | 27,900 | 8.84 | 140 | |
| UR 59 | 0_45917UC | 189 | 210 | 210 | 39,700 | 13.8 | 198 | |
| UR 64 | 0_46420UC | 210 | 290 | 290 | 61,000 | 21.9 | 320 | |

Refer to page 62 for additional hardware information.

| TYPE/SIZE | ORDERING CODE | DIMENSIONS (mm) | | | | | | |
|-------------|------------------|-----------------|---------------|--------------|-------------|-------------|-------------|------------|
| | | A | B | C | D | E | S | T |
| UR 41/21/11 | 0_44119UC | 41.78 ± 0.81 | 20.9 ± 0.12 | 11.94 ± 0.25 | 13.4 min | 18.8 ± 0.56 | 3.18 nom | 34.66 ref |
| UR 41/21 | 0_44121UC | 41.78 ± 0.81 | 20.62 ± 0.13 | 11.94 ± 0.25 | 11.1 ± 0.2 | 18.8 ± 0.56 | 3.18 ± 0.13 | 34.66 nom |
| UR 41/25 | 0_44125UC | 41.78 ± 0.81 | 25.4 ± 0.13 | 11.94 ± 0.25 | 15.9 ± 0.2 | 18.8 ± 0.56 | 3.18 ± 0.13 | 34.66 nom |
| UR 41/30 | 0_44130UC | 41.78 ± 0.81 | 30.5 ± 0.3 | 11.94 ± 0.25 | 20.8 min | 18.8 ± 0.56 | 3.18 ± 0.13 | 34.66 ref |
| UR 57 | 0_45716UC | 57.65 ± 1.7 | 28.6 + 0/-0.4 | 15.9 ± 0.4 | 15.5 + 1/-0 | 27.8 ± 0.9 | 4.8 ± 0.2 | 49.8 ± 0.8 |
| UR 59 | 0_45917UC | 59.34 ± 1.75 | 35.8 ± 0.4 | 17.0 ± 0.4 | 21.5 ± 0.8 | 26.5 ± 0.1 | 4.5 ± 0.2 | 50.5 ± 0.1 |
| UR 64 | 0_46420UC | 64.0 ± 1.95 | 40.5 ± 0.2 | 24.0 ± 0.3 | 26.5 ± 0.4 | 24.1 ± 0.9 | 4.0 min | 44.0 ± 0.6 |

EC Cores

The round center leg and open window of EC cores allow for minimum winding resistance and efficient assembly. Long legs promote low and controlled leakage inductance and are useful for high voltage applications.

EC cores have standard channels for clamping assemblies. Plain bobbins, printed circuit bobbins and clamps are available for most sizes.

Magnetics EC cores are typically used in differential mode inductor and power transformer applications.

| TYPE/SIZE | ORDERING CODE | NOMINAL A_L (mH/1000T) | | |
|-----------|------------------|--------------------------|-------|-------|
| | | R | P | F |
| EC 35 | 0_43517EC | 2,213 | 2,400 | 3,000 |
| EC 41 | 0_44119EC | 2,947 | 3,200 | 3,700 |
| EC 52 | 0_45224EC | 3,867 | 4,200 | 5,040 |
| EC 70 | 0_47035EC | 4,413 | 4,800 | 5,760 |

HOW TO ORDER

OR 47035 EC

- Shape code ←
- Ferrite core material ←
- Used for all ferrite types ←
- Approximate length in mm ←
- Approximate width in mm ←
- Geometry code ←

EC cores are sold per piece (for sets multiply by 2).
See page 18 for information on gapped cores.

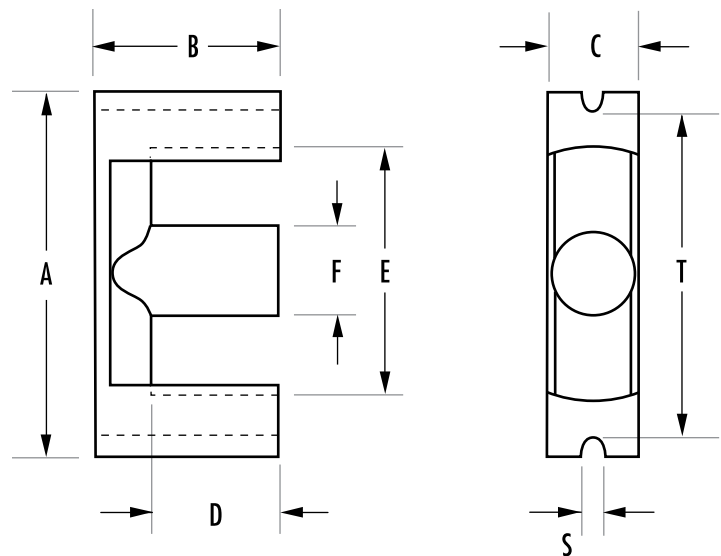

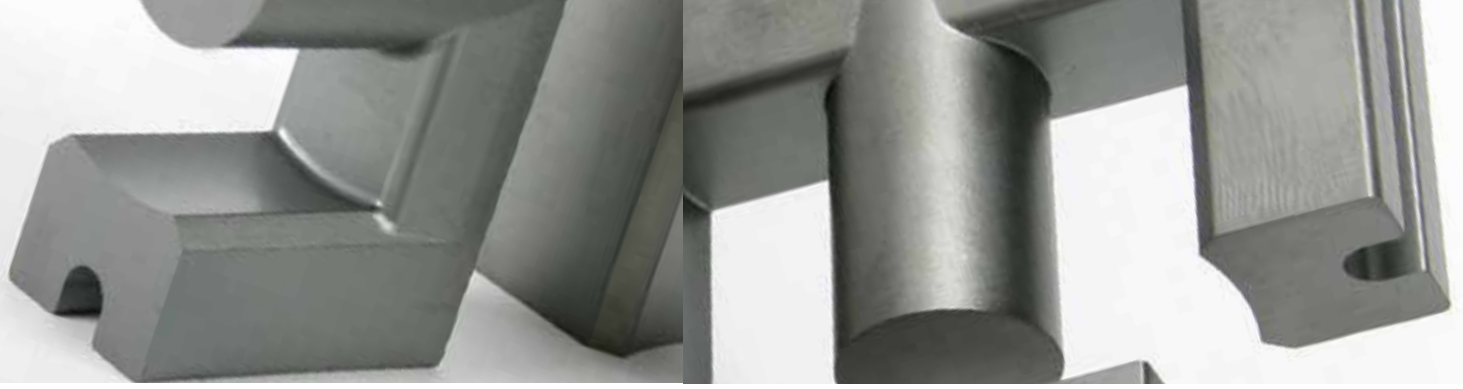

| TYPE/SIZE | ORDERING CODE | MAGNETIC DATA | | | | | | HARDWARE |
|-----------|------------------|------------------------|--------------------------------------|--|--------------------------------------|----------------------------|---------------------------|-----------|
| | | I _e (mm) | A _e (mm ²) | A _e min (mm ²) | V _e (mm ³) | WaAc (cm ⁴) | Weight (grams per set) | Bobbins |
| EC 35 | 0_43517EC | 77.4 | 84.3 | 71 | 6,530 | 0.83 | 36 | PCB351701 |
| EC 41 | 0_44119EC | 89.3 | 121 | 106 | 10,800 | 1.67 | 60 | 00B411901 |
| EC 52 | 0_45224EC | 105 | 180 | 141 | 18,800 | 3.87 | 111 | 00B5224B1 |
| EC 70 | 0_47035EC | 144 | 279 | 211 | 40,100 | 13.4 | 253 | PCB703501 |

Refer to page 62 for additional hardware information.

| TYPE/SIZE | ORDERING CODE | DIMENSIONS (mm) | | | | | | | |
|-----------|------------------|-----------------|-------------|-------------|--------------|--------------|-------------|-------------|------------|
| | | A | B | C | D | E | F | S | T |
| EC 35 | 0_43517EC | 34.5 ± 0.8 | 17.3 ± 0.15 | 9.5 ± 0.3 | 12.3 ± 0.4 | 22.75 ± 0.55 | 9.5 ± 0.3 | 2.75 ± 0.25 | 28.5 ± 0.8 |
| EC 41 | 0_44119EC | 40.6 ± 1.0 | 19.5 ± 0.15 | 11.6 ± 0.3 | 13.9 ± 0.4 | 27.7 ± 0.7 | 11.6 ± 0.3 | 3.25 ± 0.25 | 33.6 ± 1 |
| EC 52 | 0_45224EC | 52.2 ± 1.3 | 24.2 ± 0.15 | 13.4 ± 0.35 | 15.9 ± 0.4 | 33.0 ± 0.9 | 13.4 ± 0.35 | 3.75 ± 0.25 | 44.0 ± 1.3 |
| EC 70 | 0_47035EC | 70.0 ± 1.7 | 34.5 ± 0.15 | 16.4 ± 0.4 | 22.75 ± 0.45 | 44.5 ± 1.2 | 16.4 ± 0.4 | 4.75 ± 0.25 | 59.6 ± 1.7 |

EER Cores

EER cores are an economical choice for transformers and inductors. The round center leg offers the advantage of a shorter winding path length than winding around a square center leg of equal area.

Differential mode inductors and power transformers are typical applications for Magnetics EER cores.

| TYPE/SIZE | ORDERING CODE | NOMINAL A_L (mH/1000T) | | | |
|--------------|------------------|--------------------------|-------|-------|-------|
| | | L | R | P | F |
| EER 28/14/11 | 0_42814EC | 1,340 | 2,700 | 3,352 | 3,896 |
| EER 28/16/11 | 0_42817EC | 1,150 | 2,500 | 2,913 | 3,400 |
| EER 35L | 0_43521EC | | 2,693 | 2,960 | 3,550 |
| EER 40/22/13 | 0_44013EC | | 3,300 | 3,520 | 4,000 |
| EER 42 | 0_44216EC | | 3,840 | 4,173 | 5,000 |
| EER 48/18/17 | 0_44818EC | | 6,400 | 6,850 | 7,950 |
| EER 48/21/21 | 0_44821EC | | 5,700 | 7,059 | 8,274 |
| EER 53/18/18 | 0_45418EC | | 6,100 | 6,500 | 7,440 |

HOW TO ORDER

OR 44216 EC

Shape code ←
 Ferrite core material ←
 Used for all ferrite types ←
 Approximate length in mm ←
 Approximate height or width in mm ←
 Geometry code ←

EER cores are sold per piece (for sets multiply by 2).
 See page 18 for information on gapped cores.

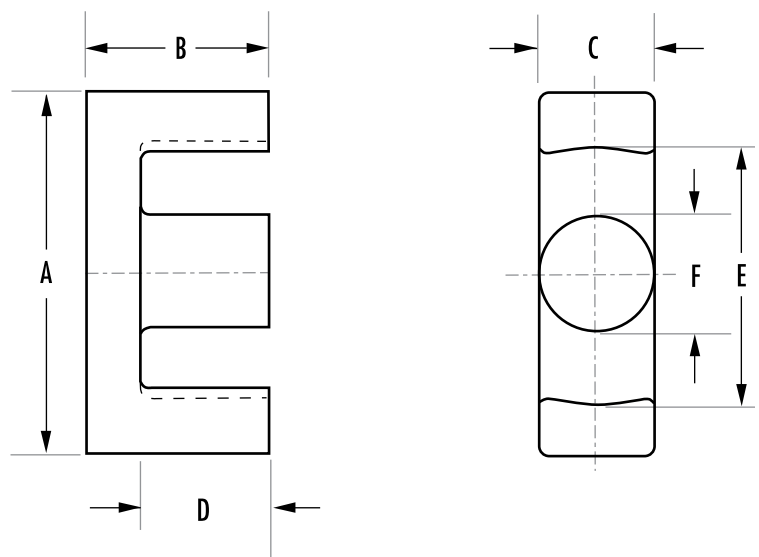

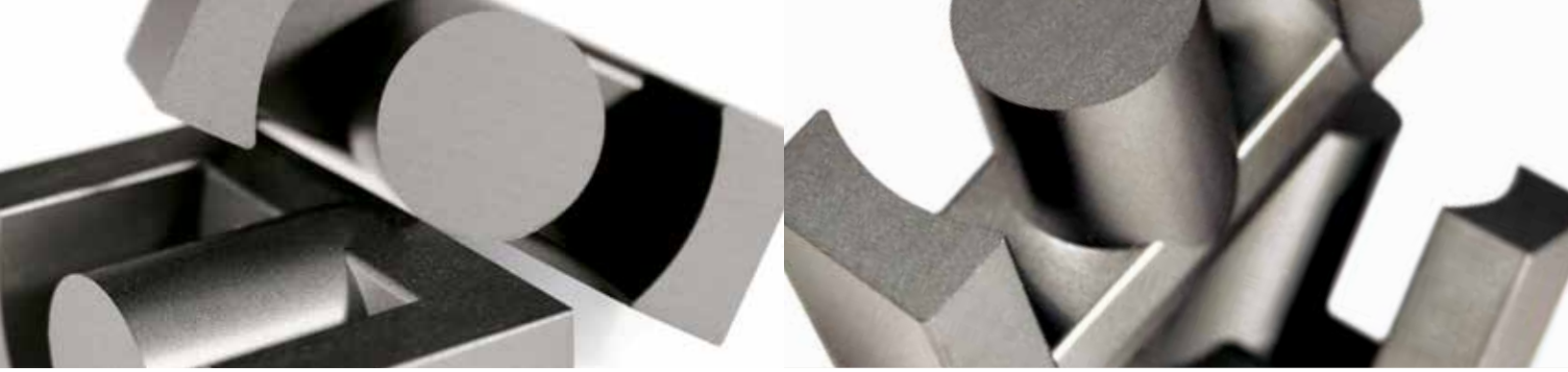

| TYPE/SIZE | ORDERING CODE | MAGNETIC DATA | | | | | | HARDWARE |
|--------------|------------------|------------------------|--------------------------------------|--|--------------------------------------|----------------------------|---------------------------|-----------|
| | | I _e (mm) | A _e (mm ²) | A _e min (mm ²) | V _e (mm ³) | WaAc (cm ⁴) | Weight (grams per set) | Bobbins |
| EER 28/14/11 | 0_42814EC | 64.0 | 81.4 | 77.0 | 5,260 | 0.532 | 28 | |
| EER 28/16/11 | 0_42817EC | 75.5 | 81.4 | 77.0 | 6,142 | 0.693 | 32 | |
| EER 35L | 0_43521EC | 90.8 | 107 | 100 | 9,710 | 1.58 | 49 | PCB3521LA |
| EER 40/22/13 | 0_44013EC | 98.0 | 149 | 139 | 14,600 | 2.16 | 74 | |
| EER 42 | 0_44216EC | 98.7 | 175 | 166 | 17,300 | 2.98 | 106 | PCB4216FA |
| EER 48/18/17 | 0_44818EC | 86.0 | 232 | 223 | 19,900 | 2.93 | 102 | |
| EER 48/21/21 | 0_44821EC | 100 | 255 | 248 | 25,500 | 4.43 | 128 | |
| EER 53/18/18 | 0_45418EC | 91.8 | 250 | 240 | 23,000 | 3.61 | 122 | |

Refer to page 62 for additional hardware information.

| TYPE/SIZE | ORDERING CODE | DIMENSIONS (mm) | | | | | |
|--------------|------------------|-----------------|---------------|---------------|---------------|---------------|-------------|
| | | A | B | C | D | E | F |
| EER 28/14/11 | 0_42814EC | 28.55 ± 0.55 | 14 ± 0.2 | 11.4 ± 0.35 | 9.75 ± 0.4 | 21.75 ± 0.5 | 9.9 ± 0.25 |
| EER 28/16/11 | 0_42817EC | 28.55 ± 0.55 | 16.7 ± 0.25 | 11.4 ± 0.35 | 12.65 ± 0.4 | 21.75 ± 0.5 | 9.9 ± 0.25 |
| EER 35L | 0_43521EC | 35.0 ± 0.65 | 20.7 ± 0.2 | 11.4 ± 0.35 | 14.75 ± 0.35 | 26.15 ± 0.55 | 11.3 ± 0.25 |
| EER 40/22/13 | 0_44013EC | 40.0 ± 0.7 | 22.4 ± 0.2 | 13.4 ± 0.35 | 15.45 ± 0.35 | 29.6 ± 0.6 | 13.3 ± 0.25 |
| EER 42 | 0_44216EC | 42.15 ± 0.85 | 21.0 ± 0.2 | 14.7 ± 0.3 | 15.6 min | 31.0 ± 0.6 | 14.7 ± 0.3 |
| EER 48/18/17 | 0_44818EC | 48.0 ± 1.0 | 18.0 ± 0.2 | 17.6 ± 0.4 | 11.45 ± 0.25 | 36.8 ± 0.8 | 17.6 ± 0.4 |
| EER 48/21/21 | 0_44821EC | 48.0 ± 1.0 | 21.2 + 0/-0.4 | 21 + 0.3/-0.5 | 14.7 + 0.7/-0 | 38 + 0.5/-0.8 | 18.0 ± 0.3 |
| EER 53/18/18 | 0_45418EC | 53.5 ± 1.0 | 18.3 ± 0.2 | 17.95 ± 0.35 | 11.1 ± 0.3 | 40.65 ± 0.85 | 17.9 ± 0.4 |

EFD Cores

The industry standard flat design of EFD cores offers excellent space utilization for transformers or inductors. The optimized cross-sectional area is ideal for very flat compact transformer applications.

EFD cores are designed for compact transformers and inductor applications.

| TYPE/SIZE | ORDERING CODE | NOMINAL A_L (mH/1000T) | | | | | |
|-----------|------------------|--------------------------|-------|-------|-------|-------|-------|
| | | L | R | P | F | T | J |
| EFD 10 | 0_41009EC | 280 | 585 | 622 | 698 | | 923 |
| EFD 12 | 0_41212EC | 380 | 760 | 800 | 844 | | 2,600 |
| EFD 15 | 0_41515EC | 400 | 893 | 973 | 1,170 | 1,140 | 1,933 |
| EFD 20 | 0_42019EC | 650 | 1,300 | 1,633 | 1,881 | 1,540 | 2,696 |
| EFD 25 | 0_42523EC | 1,000 | 2,093 | 2,280 | 2,730 | 2,660 | 4,507 |
| EFD 30 | 0_43030EC | 1,000 | 2,200 | 2,695 | 3,137 | 2,520 | 4,668 |

HOW TO ORDER

OR 4 15 15 EC

Shape code ←

Ferrite core material ←

Used for all ferrite types ←

Approximate length in mm ←

Approximate width (per set) in mm ←

Geometry code ←

EFD cores are sold per piece (for sets multiply by 2).

See page 18 for information on gapped cores.

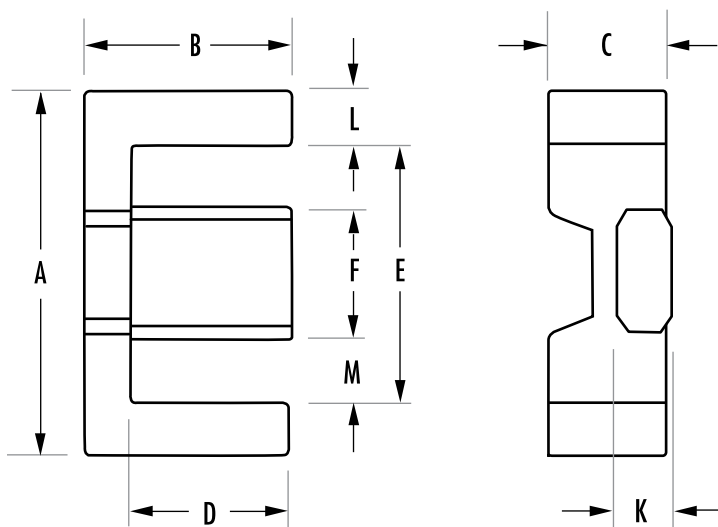



| TYPE/SIZE | ORDERING CODE | MAGNETIC DATA | | | | | | HARDWARE |
|-----------|------------------|---------------|-----------------------------|---------------------------------|-----------------------------|------------------------------|---------------------------|-----------|
| | | I_e (mm) | A_e (mm ²) | A_e min (mm ²) | V_e (mm ³) | $WaAc$ (cm ⁴) | Weight (grams per set) | Bobbins |
| EFD 10 | 0_41009EC | 23.7 | 7.2 | 6.5 | 171 | 0.004 | 0.9 | PCB1009B1 |
| EFD 12 | 0_41212EC | 28.5 | 11.4 | 10.7 | 325 | 0.01 | 1.8 | PCB1212B1 |
| EFD 15 | 0_41515EC | 34.0 | 15.0 | 12.2 | 510 | 0.02 | 2.8 | PCB1515B1 |
| EFD 20 | 0_42019EC | 47.0 | 31.0 | 29.0 | 1,460 | 0.09 | 7.0 | PCB2019B1 |
| EFD 25 | 0_42523EC | 57.0 | 58.0 | 55.0 | 3,300 | 0.24 | 16.2 | PCB2523B1 |
| EFD 30 | 0_43030EC | 68.0 | 69.0 | 66.0 | 4,700 | 0.34 | 24.0 | PCB3030B1 |

Refer to page 62 for additional hardware information.

| TYPE/SIZE | ORDERING CODE | DIMENSIONS (mm) | | | | | | | | |
|-----------|------------------|-----------------|-------------|-------------|-------------|-------------|-------------|-------------|------------|------------|
| | | A | B | C | D | E | F | K | L | M |
| EFD 10 | 0_41009EC | 10.5 ± 0.3 | 5.2 ± 0.1 | 2.7 ± 0.1 | 3.75 ± 0.15 | 7.65 ± 0.25 | 4.55 ± 0.15 | 4.45 ± 0.05 | 1.43 ref | 1.55 ref |
| EFD 12 | 0_41212EC | 12.5 ± 0.3 | 6.2 ± 0.1 | 3.5 ± 0.1 | 4.55 ± 0.15 | 9.0 ± 0.25 | 5.4 ± 0.15 | 2.0 ± 0.1 | 1.75 ref | 1.8 ref |
| EFD 15 | 0_41515EC | 15.0 ± 0.4 | 7.5 ± 0.15 | 4.65 ± 0.15 | 5.5 ± 0.25 | 11.0 ± 0.35 | 5.3 ± 0.15 | 2.4 ± 0.1 | 2.0 nom | 2.85 nom |
| EFD 20 | 0_42019EC | 20.0 ± 0.55 | 10.0 ± 0.15 | 6.65 ± 0.15 | 7.7 ± 0.25 | 15.4 ± 0.5 | 8.9 ± 0.2 | 3.6 ± 0.15 | 2.3 ref | 3.25 ref |
| EFD 25 | 0_42523EC | 25.0 ± 0.66 | 12.5 ± 0.15 | 9.1 ± 0.2 | 9.05 min | 18.1 min | 11.4 ± 0.2 | 5.2 ± 0.15 | 3.15 ± 0.2 | 3.65 ± 0.2 |
| EFD 30 | 0_43030EC | 30.0 ± 0.8 | 15.0 ± 0.15 | 9.1 ± 0.2 | 11.2 ± 0.3 | 22.4 ± 0.75 | 14.6 ± 0.25 | 4.9 ± 0.15 | 3.8 ref | 3.9 ref |

ETD Cores

ETD cores are an economical choice for transformers or inductors. ETDs offer a round center leg for minimum winding resistance. Dimensions are optimized for power transformer efficiency.

Typical applications of Magnetics ETD cores include differential mode inductors and power transformers.

| TYPE/SIZE | ORDERING CODE | NOMINAL A_L (mH/1000T) | | | | |
|-----------|------------------|--------------------------|-------|-------|-------|-------|
| | | L | R | P | F | T |
| ETD 29 | 0_42929EC | 1,100 | 2,250 | 2,843 | 3,316 | |
| ETD 34 | 0_43434EC | | 2,707 | 2,933 | 3,600 | |
| ETD 39 | 0_43939EC | | 2,973 | 3,227 | 4,050 | 3,650 |
| ETD 44 | 0_44444EC | | 3,667 | 4,000 | 4,950 | 4,460 |
| ETD 49 | 0_44949EC | | 4,093 | 4,440 | 5,400 | 5,140 |
| ETD 54 | 0_45454EC | | 5,200 | 6,281 | 7,400 | |
| ETD 59 | 0_45959EC | | 5,747 | 6,240 | 7,500 | 7,340 |
| ETD 69 | 0_47054EC | | | 3,533 | | |

HOW TO ORDER

OR 43939 EC

- Shape code ←
- Ferrite core material ←
- Used for all ferrite types ←
- Approximate length in mm ←
- Approximate height (per set) in mm ←
- Geometry code ←

ETD cores are sold per piece (for sets multiply by 2.)
See page 18 for information on gapped cores.

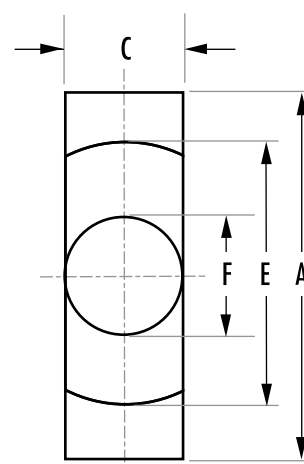
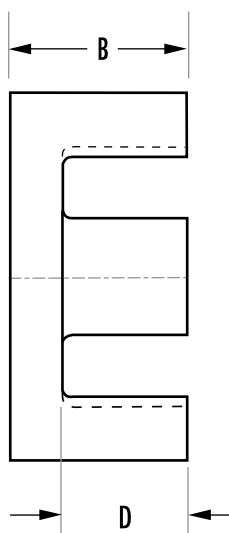

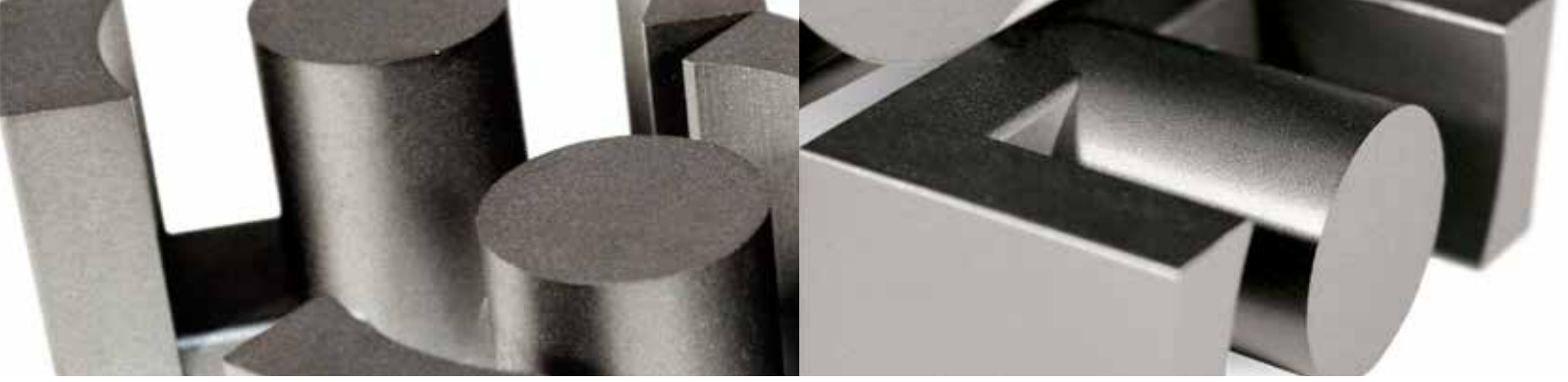

| TYPE/SIZE | ORDERING CODE | MAGNETIC DATA | | | | | | HARDWARE |
|-----------|------------------|---------------|-----------------------------|---------------------------------|-----------------------------|----------------------------|---------------------------|-----------|
| | | I_e (mm) | A_e (mm ²) | A_e min (mm ²) | V_e (mm ³) | WaAc (cm ⁴) | Weight (grams per set) | Bobbins |
| ETD 29 | 0_42929EC | 72.0 | 76.0 | 71.0 | 5,470 | 0.71 | 28 | PCB2929B1 |
| ETD 34 | 0_43434EC | 78.6 | 97.1 | 91.6 | 7,640 | 1.19 | 40 | PCB3434FB |
| ETD 39 | 0_43939EC | 92.2 | 125 | 123 | 11,500 | 2.18 | 60 | PCB3939SB |
| ETD 44 | 0_44444EC | 103 | 173 | 172 | 17,800 | 3.68 | 94 | PCB444418 |
| ETD 49 | 0_44949EC | 114 | 211 | 209 | 24,000 | 5.72 | 124 | PCB4949WA |
| ETD 54 | 0_45454EC | 127 | 280 | 280 | 35,500 | 8.88 | 180 | PCB5454B1 |
| ETD 59 | 0_45959EC | 139 | 368 | 360 | 51,500 | 13.7 | 248 | PCB5959AA |
| ETD 69 | 0_47054EC | 231 | 334 | 314 | 77,100 | 35.7 | 371 | |

Refer to page 62 for additional hardware information.

| TYPE/SIZE | ORDERING CODE | DIMENSIONS (mm) | | | | | |
|-----------|------------------|-----------------|------------|--------------|-------------|-----------------|--------------|
| | | A | B | C | D | E | F |
| ETD 29 | 0_42929EC | 30.6 +0/-1.6 | 15.8 ± 0.2 | 9.8 +0/-0.6 | 11.0 ± 0.3 | 22.0 +1.4/0 | 9.8 +0/-0.6 |
| ETD 34 | 0_43434EC | 35.0 +0/-1.6 | 17.3 ± 0.2 | 11.1 +0/-0.6 | 11.8 +0.6/0 | 25.6 +1.4/0 | 11.1 +0/-0.6 |
| ETD 39 | 0_43939EC | 40.0 +0/-1.8 | 19.8 ± 0.2 | 12.8 +0/-0.6 | 14.2 +0.8/0 | 29.3 +1.6/0 | 12.8 +0/-0.6 |
| ETD 44 | 0_44444EC | 45.0 +0/-2.0 | 22.3 ± 0.2 | 15.2 +0/-0.6 | 16.1 +0.8/0 | 32.5 +1.6/0 | 15.2 +0/-0.6 |
| ETD 49 | 0_44949EC | 49.8 +0/-2.2 | 24.7 ± 0.2 | 16.7 +0/-0.6 | 17.7 +0.8/0 | 36.1 +1.8/0 | 16.7 +0/-0.6 |
| ETD 54 | 0_45454EC | 54.5 ± 1.3 | 27.6 ± 0.2 | 18.9 ± 0.4 | 20.2 ± 0.4 | 41.2 ± 1.1 | 18.9 ± 0.4 |
| ETD 59 | 0_45959EC | 59.8 ± 1.3 | 31.0 ± 0.2 | 21.65 ± 0.45 | 22.1 min | 44.7 ± 1.09 | 21.65 ± 0.45 |
| ETD 69 | 0_47054EC | 68.58 ± 2.1 | 54.0 ± 0.4 | 20.0 ± 0.6 | 41.85 min | 54.1 +1.35/-1.6 | 20.0 ± 0.5 |

Block Cores

Ferrites can be pressed in block form and then machined into intricate shapes. Where large sizes are required, it is possible to assemble them from two or more smaller machined or pressed sections; the variety of sizes and shapes becomes limitless.

Features of Magnetics ferrite blocks include low porosity, extreme hardness, uniform physical properties, high density and ease of machining. J material offers high permeability; R material is suitable for power applications.

| TYPE/SIZE | ORDERING CODE | AVAILABLE MATERIALS | | | | |
|---------------|------------------|---------------------|---|---|---|---|
| | | L | R | P | F | J |
| I 11/4/6 | O_41106IC | | ✓ | ✓ | ✓ | ✓ |
| I 12.5/8.5 | O_41308IC | ✓ | ✓ | ✓ | ✓ | |
| I 18 | F_41805IC | ✓ | ✓ | ✓ | ✓ | |
| I 20/7/14 | F_42014IC | ✓ | ✓ | ✓ | ✓ | |
| I 22/4/7 | O_42107IC | ✓ | ✓ | ✓ | ✓ | |
| I 22 | F_42216IC | ✓ | ✓ | ✓ | ✓ | |
| I 25/6/6 | O_42516IC | ✓ | ✓ | ✓ | ✓ | ✓ |
| I 32 | F_43208IC | ✓ | ✓ | ✓ | ✓ | |
| I 36/6/18 | O_43618IC | | ✓ | ✓ | | |
| I 38 | F_43808IC | ✓ | ✓ | ✓ | ✓ | |
| I 40/4/10 | O_44008IC | | ✓ | ✓ | ✓ | ✓ |
| I 43/6/15 | O_44020IC | | ✓ | ✓ | | |
| I 43/4/28 | O_44308IC | | ✓ | ✓ | ✓ | |
| I 43 | F_44310IC | | ✓ | ✓ | ✓ | |
| I 58 | F_45810IC | | ✓ | ✓ | ✓ | |
| I 64 | F_46410IC | | ✓ | ✓ | ✓ | |
| I 93/28/16 | O_49316IC | | ✓ | ✓ | ✓ | ✓ |
| I 102/25/25 | O_49925IC | | ✓ | ✓ | ✓ | |
| FB 104/66/18 | O_49966FB | | ✓ | ✓ | | ✓ |
| FB 100/85/25 | O_49985FB | | ✓ | | | |
| FB 120/120/38 | O_49938FB | | ✓ | | | |

HOW TO ORDER

O R 4 99 66 FB

Shape code ←
 Ferrite core material ←
 Used for all ferrite types ←
 Approximate length in mm ←
 Approximate height in mm ←
 Geometry code ←

GEOMETRY CODE

IC – I core

FB – Block core

Block cores and I cores are sold per piece.

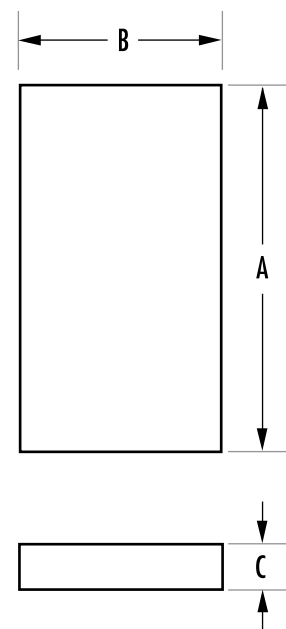



| TYPE/SIZE | ORDERING CODE | DIMENSIONS (mm) | | | Weight (grams per piece) |
|---------------|------------------|-------------------|-------------|---------------|--------------------------|
| | | A | B | C | |
| I 11/4/6 | O_41106IC | 10.8 ± 0.2 | 1.83 ± 0.12 | 6.3 ± 0.13 | 0.7 |
| I 12.5/8.5 | O_41308IC | 12.8 ± 0.3 | 1.1 ± 0.1 | 8.7 ± 0.25 | 0.6 |
| I 18 | F_41805IC | 18.0 ± 0.41 | 2.39 ± 0.1 | 10.0 ± 0.2 | 1.8 |
| I 20/7/14 | F_42014IC | 20.0 ± 0.35 | 1.9 ± 0.05 | 14.0 ± 0.3 | 2.4 |
| I 22/4/7 | O_42107IC | 21.8 ± 0.4 | 2.3 ± 0.2 | 7.8 ± 0.3 | 2.4 |
| I 22 | F_42216IC | 21.8 ± 0.4 | 2.95 ± 0.1 | 15.8 ± 0.3 | 4.0 |
| I 25/6/6 | O_42516IC | 25.4 + 0.64/-0.51 | 6.35 ± 0.13 | 6.35 ± 0.13 | 4.5 |
| I 32 | F_43208IC | 31.75 ± 0.64 | 3.18 ± 0.13 | 20.32 ± 0.41 | 10.0 |
| I 36/6/18 | O_43618IC | 35.56 ± 0.05 | 3.68 ± 0.3 | 17.8 ± 0.4 | 11.0 |
| I 38 | F_43808IC | 38.1 ± 0.76 | 3.81 ± 0.13 | 25.4 ± 0.51 | 18.0 |
| I 40/4/10 | O_44008IC | 40.64 ± 0.5 | 4.45 ± 0.25 | 10.7 ± 0.25 | 9.0 |
| I 43/6/15 | O_44020IC | 43.0 + 0/-1.7 | 5.9 ± 0.2 | 15.2 + 0/-0.6 | 19.2 |
| I 43/4/28 | O_44308IC | 43.2 ± 0.9 | 4.1 ± 0.13 | 27.9 ± 0.6 | 24.0 |
| I 43 | F_44310IC | 43.2 ± 0.9 | 4.1 ± 0.13 | 27.9 ± 0.6 | 24.0 |
| I 58 | F_45810IC | 58.42 ± 1.2 | 4.06 ± 0.12 | 38.1 ± 0.8 | 44.0 |
| I 64 | F_46410IC | 64.0 ± 1.27 | 5.08 ± 0.13 | 50.8 ± 1.02 | 78.0 |
| I 93/28/16 | O_49316IC | 93.0 ± 1.8 | 27.5 ± 0.5 | 16.0 ± 0.6 | 200 |
| I 102/25/25 | O_49925IC | 101.6 ± 1.5 | 25.4 ± 0.4 | 25.4 ± 0.6 | 310 |
| FB 104/66/18 | O_49966FB | 104.0 ± 2 | 66.0 ± 1.5 | 18.5 ± 0.4 | 595 |
| FB 100/85/25 | O_49985FB | 100.0 ± 2 | 85.0 ± 2 | 25.4 ± 0.5 | 1,065 |
| FB 120/120/38 | O_49938FB | 120.0 ± 3 | 120.0 ± 3 | 38.0 ± 0.5 | 2,699 |

EP Cores

EP cores are round center post cubical shapes which enclose the coil completely except for the printed circuit board terminals. This particular shape minimizes the effect of air gaps formed at mating surfaces in the magnetic path and provides a larger volume ratio to total space used. EP cores provide excellent shielding.

Typical applications for EP cores include differential mode and telecom inductors and signal transformers.

| TYPE/SIZE | ORDERING CODE | NOMINAL A_L (mH/1000T) | | | | | | |
|-----------|------------------|--------------------------|-------|-------|-------|-------|-------|--------|
| | | L | R | P | F | T | J | W |
| EP 7 | P_40707UG | 590 | 1,080 | 1,173 | 1,240 | | 2,573 | 5,143 |
| EP 10 | P_41010UG | 530 | 1,040 | 1,133 | 1,200 | 1,360 | 2,467 | 4,800 |
| EP 13 | P_41313UG | 760 | 1,533 | 1,667 | 2,000 | 2,000 | 3,733 | 7,143 |
| EP 17 | P_41717UG | 1,120 | 2,387 | 2,600 | 3,100 | 3,100 | 5,867 | 11,429 |
| EP 20 | P_42120UG | 1,930 | 4,227 | 4,600 | 5,000 | 5,000 | 9,600 | 19,286 |

HOW TO ORDER

P J 4 10 10 UG

- Shape code ←
- Ferrite core material ←
- Used for all ferrite types ←
- Approximate length in mm ←
- Approximate height (per set) in mm ←
- Geometry code ←

EP cores are sold in sets.
See page 19 for information on gapped cores.

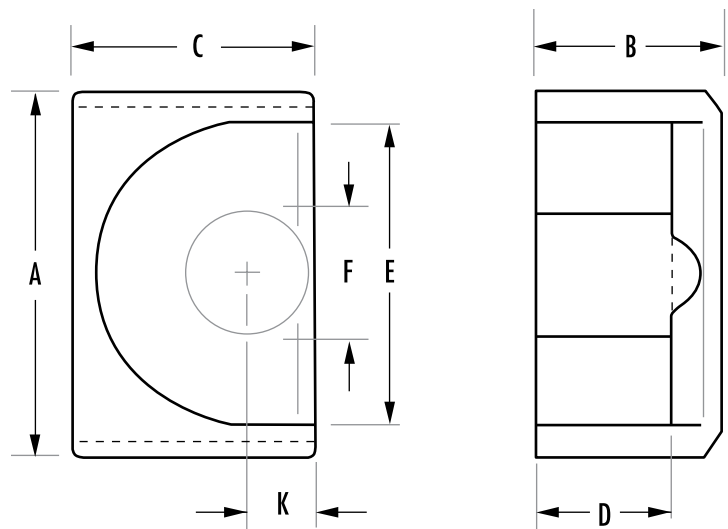

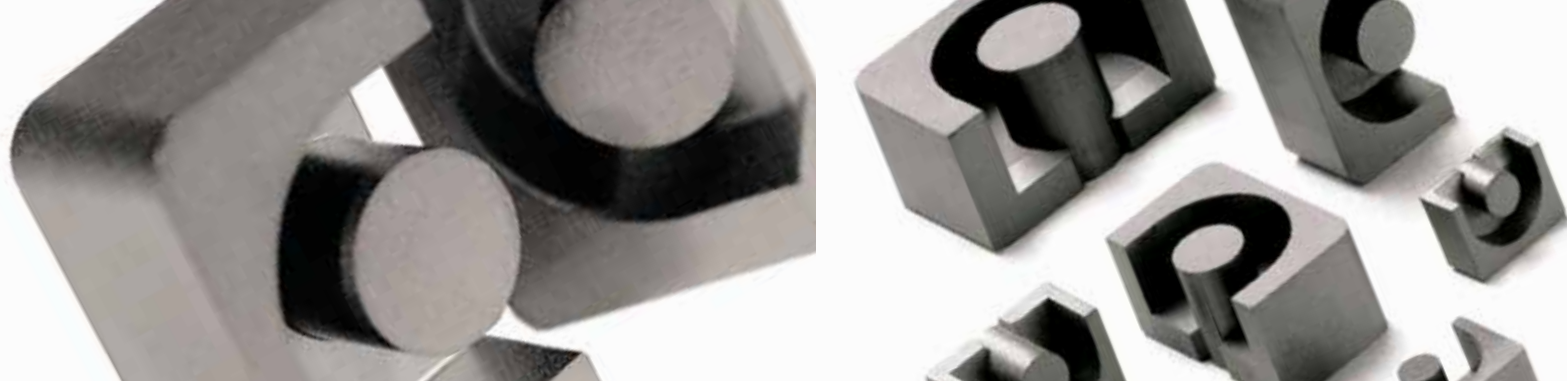

| TYPE/SIZE | ORDERING CODE | MAGNETIC DATA | | | | | | HARDWARE |
|-----------|------------------|---------------|-----------------------------|---------------------------------|-----------------------------|------------------------------|---------------------------|-----------|
| | | I_e (mm) | A_e (mm ²) | A_e min (mm ²) | V_e (mm ³) | $WaAc$ (cm ⁴) | Weight (grams per set) | Bobbins |
| EP 7 | P_40707UG | 15.5 | 10.7 | 8.55 | 165 | 0.005 | 1.4 | SMB07076A |
| EP 10 | P_41010UG | 19.3 | 11.3 | 8.55 | 215 | 0.01 | 2.8 | PCB10108A |
| EP 13 | P_41313UG | 24.2 | 19.5 | 14.9 | 472 | 0.03 | 5.1 | PCB1313B1 |
| EP 17 | P_41717UG | 29.5 | 33.7 | 25.5 | 999 | 0.06 | 11.6 | PCB17178A |
| EP 20 | P_42120UG | 41.1 | 78.7 | 60.8 | 3,230 | 0.24 | 27.6 | PCB2120VB |

Refer to page 62 for additional hardware information.

| TYPE/SIZE | ORDERING CODE | DIMENSIONS (mm) | | | | | | | | |
|-----------|------------------|-----------------|-------------|-------------|-------------|-------------|-------------|-------------|-------------|------------|
| | | A | B | 2B | C | D | 2D | E | F | K |
| EP 7 | P_40707UG | 9.2 ± 0.2 | 3.7 ± 0.05 | 7.4 ± 0.1 | 6.35 ± 0.15 | 2.5 min | 5.0 min | 7.2 min | 3.4 max | 1.7 ± 0.1 |
| EP 10 | P_41010UG | 11.5 ± 0.3 | 5.15 ± 0.1 | 10.3 ± 0.2 | 7.6 ± 0.2 | 3.6 min | 7.2 min | 9.2 min | 3.45 max | 1.85 ± 0.1 |
| EP 13 | P_41313UG | 12.8 +0/-0.6 | 6.45 ± 0.08 | 12.9 ± 0.16 | 9.0 +0/-0.4 | 4.5 +0.2/-0 | 9.0 +0.4/-0 | 9.7 +0.6/-0 | 4.5 +0/-0.3 | 2.4 ± 0.1 |
| EP 17 | P_41717UG | 18.0 ± 0.4 | 8.4 ± 0.1 | 16.8 ± 0.2 | 11.0 ± 0.25 | 5.7 ± 0.15 | 11.4 ± 0.3 | 12.0 ± 0.4 | 5.7 ± 0.18 | 3.3 ± 0.2 |
| EP 20 | P_42120UG | 24.0 ± 0.5 | 10.7 ± 0.1 | 21.4 ± 0.2 | 15.0 ± 0.35 | 7.2 ± 0.15 | 14.4 ± 0.3 | 16.5 ± 0.4 | 8.8 ± 0.25 | 4.5 ± 0.2 |

Pot Cores

Pot cores offer superior shielding and convenient mounting. Typical applications for pot cores include differential mode inductors, power transformers, power inductors, converter and inverter transformers, broadband and narrowband filters, transformers and telecom inductors.

| TYPE/SIZE | ORDERING CODE | NOMINAL A_L (mH/1000T) | | | | | | | | |
|-----------|------------------|--------------------------|--------|--------|--------|--------|--------|-------|-------|-------|
| | | R | P | F | T | J | W | C | E | V |
| PC 7/4 | 0_40704UG | 886 | 964 | 1,200 | | 2,257 | 4,286 | | 900 | 950 |
| PC 9/5 | 0_40905UG | 1,013 | 1,100 | 1,365 | | 2,727 | 6,029 | 640 | | |
| PC 11/7 | 0_41107UG | 1,533 | 1,667 | 2,000 | | 3,900 | 7,666 | 800 | 1,650 | 1,800 |
| PC 11/9 | 0_41109UG | 1,467 | 1,573 | 1,900 | | | | | | |
| PC 14/8 | 0_41408UG | 2,053 | 2,240 | 2,800 | 2,800 | 5,073 | 8,400 | 1,100 | 2,100 | 2,240 |
| PC 18/11 | 0_41811UG | 3,067 | 3,333 | 4,000 | | 7,500 | 12,000 | 1,400 | 3,000 | 3,650 |
| PC 18/14 | 0_41814UG | 3,076 | 3,268 | 3,350 | | 5,088 | | | | |
| PC 22/13 | 0_42213UG | 4,040 | 4,400 | 4,900 | 5,200 | 9,100 | 16,000 | 1,700 | 3,900 | 4,650 |
| PC 34/28 | 0_42438UG | | | 7,550 | | | | | | |
| PC 26/16 | 0_42616UG | 5,213 | 5,667 | 6,350 | | 11,700 | 20,000 | | | 6,000 |
| PC 28/23 | 0_42823UG | | | 7,000 | | | | | | |
| PC 30/19 | 0_43019UG | 6,680 | 7,267 | 8,100 | | 15,100 | 25,000 | 2,800 | 8,000 | 7,000 |
| PC 36/22 | 0_43622UG | 8,700 | 9,467 | 10,200 | 10,800 | 17,500 | 32,667 | | | 9,000 |
| PC 42/29 | 0_44229UG | 9,200 | 10,000 | 12,000 | 11,450 | | 40,000 | | | 9,000 |

HOW TO ORDER

OP 4 14 08 UG

- Shape code ←
- Ferrite core material ←
- Used for all ferrite types ←
- Approximate diameter in mm ←
- Approximate height (per set) in mm ←
- Geometry code ←

Pot cores are sold in sets.
See page 19 for information on gapped cores.

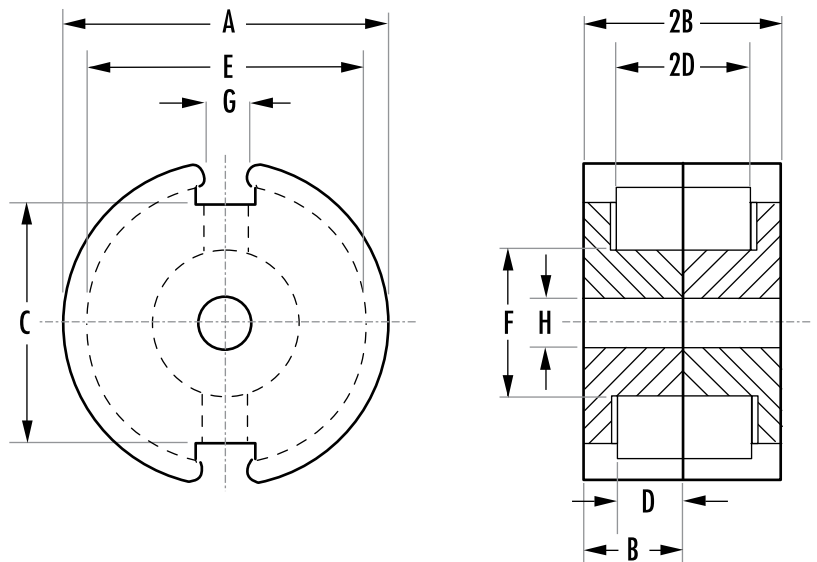

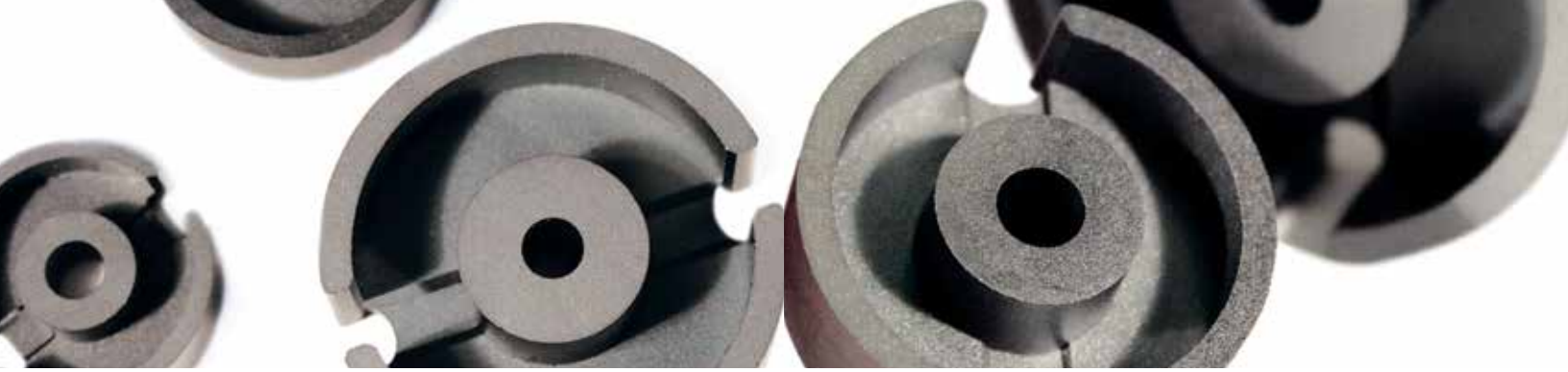

| TYPE/SIZE | ORDERING CODE | MAGNETIC DATA | | | | | | HARDWARE |
|-----------|------------------|------------------------|--------------------------------------|--|--------------------------------------|----------------------------|---------------------------|-----------|
| | | I _e (mm) | A _e (mm ²) | A _e min (mm ²) | V _e (mm ³) | WaAc (cm ⁴) | Weight (grams per set) | Bobbins |
| PC 7/4 | 0_40704UG | 9.9 | 7.0 | 5.9 | 69 | 0.002 | 0.5 | 00B0704B1 |
| PC 9/5 | 0_40905UG | 12.5 | 10.1 | 8.0 | 126 | 0.003 | 0.8 | 00B090501 |
| PC 11/7 | 0_41107UG | 15.5 | 16.2 | 13.2 | 251 | 0.006 | 1.8 | 00B1107B1 |
| PC 11/9 | 0_41109UG | 16.2 | 16.3 | 13.2 | 264 | 0.01 | 1.9 | |
| PC 14/8 | 0_41408UG | 19.8 | 25.1 | 19.8 | 495 | 0.02 | 3.2 | PCB1408TE |
| PC 18/11 | 0_41811UG | 25.8 | 43.3 | 36.0 | 1,120 | 0.07 | 6.4 | PCB181111 |
| PC 18/14 | 0_41814UG | 29.3 | 42.6 | 36.0 | 1,248 | 0.09 | 7.4 | |
| PC 22/13 | 0_42213UG | 31.5 | 63.4 | 50.9 | 2,000 | 0.18 | 13 | PCB221311 |
| PC 26/16 | 0_42616UG | 37.6 | 93.9 | 77.4 | 3,530 | 0.39 | 20 | PCB261611 |
| PC 28/23 | 0_42823UG | 48.1 | 128 | 101 | 6,160 | 0.58 | 32 | 00B282301 |
| PC 30/19 | 0_43019UG | 45.2 | 137 | 116 | 6,190 | 0.74 | 34 | PCB301911 |
| PC 34/28 | 0_43428UG | 58.1 | 159 | 122 | 9,230 | 22.4 | 47 | |
| PC 36/22 | 0_43622UG | 53.2 | 202 | 172 | 10,700 | 1.53 | 57 | PCB362211 |
| PC 42/29 | 0_44229UG | 68.6 | 265 | 214 | 18,200 | 3.68 | 104 | PCB4229L1 |

Refer to page 62 for additional hardware information.

| TYPE/SIZE | ORDERING CODE | DIMENSIONS (mm) | | | | | | | | | |
|-----------|------------------|-----------------|---------------|--------------|-------------|--------------|--------------|--------------|--------------|-------------|---------------|
| | | A | B | 2B | C | D | 2D | E | F | G | H |
| PC 7/4 | 0_40704UG | 7.24 ± 0.15 | 2.08 ± 0.05 | 4.16 ± 0.1 | 4.72 nom | 1.4 min | 2.79 min | 5.74 min | 3.0 max | 1.52 min | 1.09 ± 0.05 |
| PC 9/5 | 0_40905UG | 9.3 + 0/-0.3 | 2.7 + 0/-0.15 | 5.4 + 0/-0.3 | 6.5 ± 0.25 | 1.8 + 0.15/0 | 3.6 + 0.3/0 | 7.5 + 0.25/0 | 3.9 + 0/-0.2 | 2.0 ± 0.2 | 2.04 + 0.06/0 |
| PC 11/7 | 0_41107UG | 11.1 ± 0.2 | 3.25 ± 0.05 | 6.5 ± 0.1 | 6.8 ± 0.25 | 2.2 + 0.15/0 | 4.4 + 0.3/0 | 9.0 + 0.4/0 | 4.7 + 0/-0.2 | 2.2 ± 0.3 | 2.1 ± 0.1 |
| PC 11/9 | 0_41109UG | 11.28 + 0/-0.4 | 3.43 ± 0.08 | 6.86 ± 0.16 | 7.54 ± 0.2 | 2.48 ± 0.08 | 4.96 ± 0.16 | 9.0 + 0.4/0 | 4.7 + 0/-0.2 | 1.8 + 0.3/0 | 2.0 + 0.08/0 |
| PC 14/8 | 0_41408UG | 14.3 + 0/-0.5 | 4.18 ± 0.06 | 8.35 ± 0.13 | 9.5 ± 0.3 | 2.8 + 0.2/0 | 5.6 + 0.4/0 | 11.6 + 0.4/0 | 6.0 + 0/-0.2 | 2.7 + 1.2/0 | 3.1 ± 0.1 |
| PC 18/11 | 0_41811UG | 18.0 ± 0.4 | 5.3 ± 0.05 | 10.6 ± 0.1 | 13.4 ± 0.3 | 3.7 ± 0.1 | 7.4 ± 0.2 | 15.15 ± 0.25 | 7.45 ± 0.15 | 3.8 ± 0.6 | 3.1 ± 0.1 |
| PC 18/14 | 0_41814UG | 18.0 ± 0.4 | 7.1 ± 0.2 | 14.2 ± 0.4 | 11.8 ± 0.25 | 5.05 + 0.2/0 | 10.1 + 0.4/0 | 14.0 + 0.4/0 | 7.4 + 0/-0.3 | 3.6 + 0.3/0 | 3.1 ± 0.08 |
| PC 22/13 | 0_42213UG | 22.0 + 0/-0.8 | 6.7 ± 0.1 | 13.4 ± 0.2 | 15.0 ± 0.4 | 4.6 + 0.2/0 | 9.2 + 0.4/0 | 17.9 + 0.6/0 | 9.4 + 0/-0.3 | 3.8 ± 0.6 | 4.4 + 0.3/0 |
| PC 34/28 | 0_42438UG | 33.7 ± 0.5 | 13.9 ± 0.2 | 27.8 ± 0.4 | 24.8 ± 0.5 | 10.2 ± 0.15 | 20.4 ± 0.3 | 27.5 ± 0.6 | 13.65 ± 0.3 | 6.5 ± 0.3 | 5.56 ± 0.1 |
| PC 26/16 | 0_42616UG | 25.5 ± 0.5 | 8.05 ± 0.1 | 16.1 ± 0.2 | 18.0 ± 0.4 | 5.5 min | 11.0 min | 21.6 ± 0.4 | 11.3 ± 0.2 | 3.8 ± 0.6 | 5.5 ± 0.1 |
| PC 28/23 | 0_42823UG | 27.7 ± 0.4 | 11.43 ± 0.15 | 22.86 ± 0.3 | 19.7 nom | 8.15 min | 16.3 min | 22.0 min | 12.88 max | 3.81 min | 5.56 ± 0.1 |
| PC 30/19 | 0_43019UG | 30.0 ± 0.5 | 9.45 ± 0.05 | 18.9 ± 0.1 | 20.5 ± 0.5 | 6.5 min | 13.0 min | 25.4 ± 0.4 | 13.3 ± 0.2 | 4.3 ± 0.6 | 5.5 ± 0.1 |
| PC 36/22 | 0_43622UG | 35.6 ± 0.6 | 10.95 ± 0.05 | 21.9 ± 0.1 | 26.2 ± 0.6 | 7.3 min | 14.6 min | 30.4 ± 0.5 | 15.9 ± 0.3 | 4.9 ± 0.6 | 5.55 ± 0.15 |
| PC 42/29 | 0_44229UG | 42.4 ± 0.7 | 14.7 ± 0.05 | 29.4 ± 0.1 | 32.0 ± 0.7 | 10.15 min | 20.3 min | 36.3 ± 0.7 | 17.4 ± 0.3 | 5.1 ± 0.6 | 5.55 ± 0.15 |

RS-DS Cores

Slab cores are the same as pot cores except for wider wire openings. A slab piece can be paired with a standard pot core round to make an RS combination, or two slabs can be paired for a double slab (DS).

The RS geometry offers most of the shielding of a pot core but with more space available for terminating leads. DS cores offer a good compromise between shielding and thermal management.

Typical applications for RS and DS combinations include low and medium power transformers, switched-mode power supplies, and multiple output converter and inverter transformers.

| TYPE/SIZE | ORDERING CODE | NOMINAL A_L (mH/1000T) | | | | |
|-----------|------------------|--------------------------|-------|--------|--------|--------|
| | | R | P | F | J | W |
| DS 14/08 | D 41408UG | 1,653 | 1,800 | 2,474 | 3,260 | 7,929 |
| HS 14/08 | H 41408UG | 1,533 | 1,667 | 1,990 | 4,107 | 7,043 |
| RS 14/08 | S 41408UG | 1,760 | 1,913 | 2,274 | 4,500 | 7,643 |
| DS 18/11 | D 41811UG | 3,038 | 3,236 | 3,697 | 5,174 | 7,386 |
| HS 18/11 | H 41811UG | 2,666 | 2,827 | 3,197 | 5,140 | 5,899 |
| RS 18/11 | S 41811UG | 2,942 | 3,112 | 3,498 | 5,760 | 6,194 |
| DS 23/11 | D 42311UG | 3,440 | 3,747 | 4,460 | 8,400 | 16,064 |
| HS 23/11 | H 42311UG | 3,200 | 3,460 | 4,170 | 7,853 | 14,021 |
| RS 23/11 | S 42311UG | 3,687 | 4,013 | 5,200 | 7,875 | 16,071 |
| DS 23/18 | D 42318UG | 2,907 | 3,160 | 3,800 | 6,347 | 10,000 |
| HS 23/18 | H 42318UG | 2,600 | 2,820 | 3,350 | 5,333 | 10,000 |
| RS 23/18 | S 42318UG | 3,066 | 3,333 | 4,000 | 6,400 | 12,000 |
| DS 26/16 | D 42616UG | 3,827 | 4,160 | 5,000 | 8,093 | 13,000 |
| HS 26/16 | H 42616UG | 3,630 | 3,840 | 4,600 | 8,107 | 13,000 |
| RS 26/16 | S 42616UG | 4,360 | 4,733 | 5,300 | 8,933 | 15,714 |
| DS 30/19 | D 43019UG | 4,440 | 4,827 | 5,800 | 9,493 | 15,000 |
| HS 30/19 | H 43019UG | 4,227 | 4,600 | 5,525 | 9,507 | 15,000 |
| RS 30/19 | S 43019UG | 5,533 | 6,027 | 6,700 | 11,147 | 18,571 |
| DS 36/22 | D 43622UG | 5,400 | 5,827 | 6,360 | 9,000 | 19,000 |
| HS 36/22 | H 43622UG | 5,200 | 5,400 | 6,050 | 8,550 | 18,100 |
| RS 36/22 | S 43622UG | 7,120 | 7,580 | 8,660 | 13,400 | 26,500 |
| DS 42/29* | D 44229UG | 6,500 | 7,000 | 7,900 | 12,200 | |
| RS 42/29 | S 44229UG | 8,300 | 8,900 | 10,400 | 17,500 | |

HOW TO ORDER

S P 4 23 11 UG

Shape code ←
 Ferrite core material ←
 Used for all ferrite types ←
 Approximate length in mm ←
 Approximate height (per set) in mm ←
 Geometry code ←

SHAPE CODE

D - DS Core with solid center post
 H - DS Core with center hole
 S - RS core

RS-DS cores are sold in sets.
 See page 19 for information on gapped cores.
 *For DS 42/29 size, see datasheets for differences in geometry.

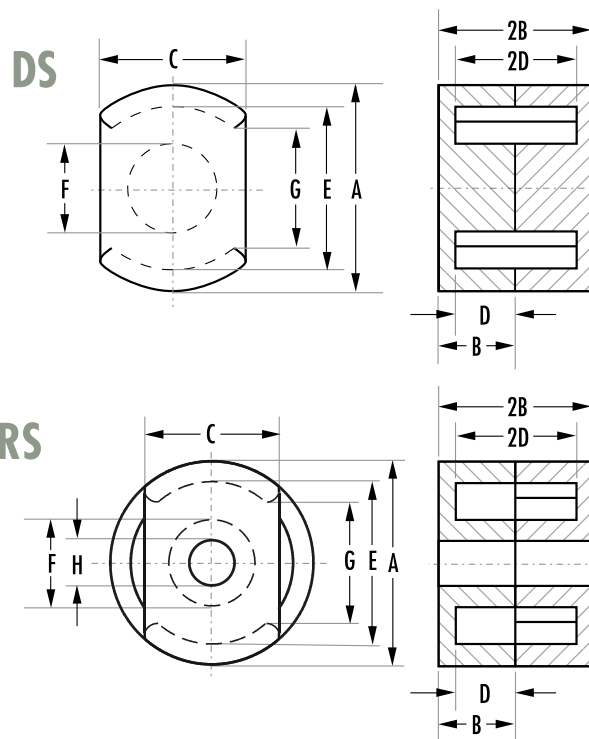

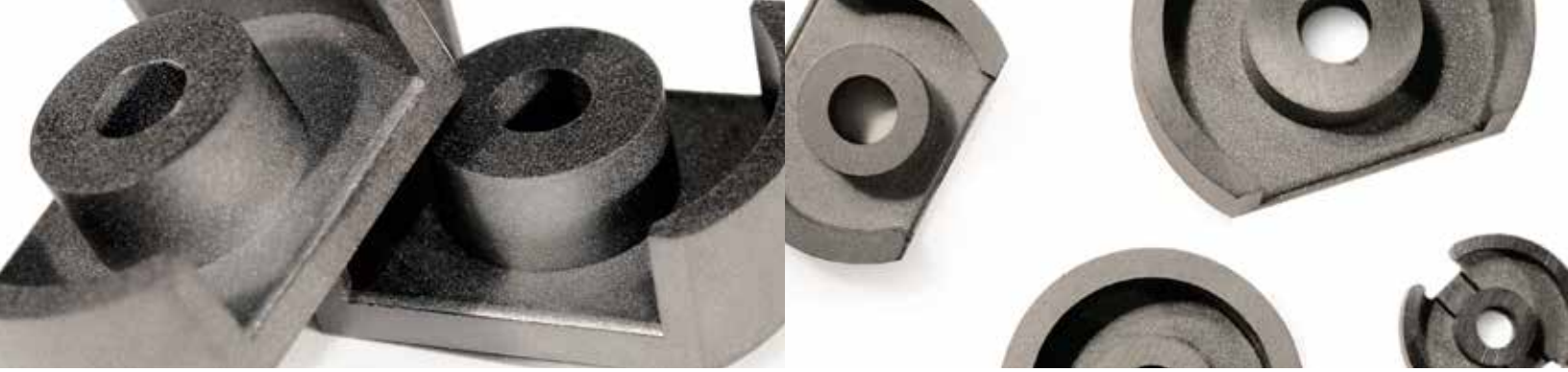

| TYPE/SIZE | ORDERING CODE | MAGNETIC DATA | | | | | | HARDWARE |
|-----------|------------------|------------------------|--------------------------------------|--|--------------------------------------|----------------------------|---------------------------|-----------|
| | | I _e (mm) | A _e (mm ²) | A _e min (mm ²) | V _e (mm ³) | WaAc (cm ⁴) | Weight (grams per set) | Bobbins |
| DS 14/08 | D 41408UG | 22.6 | 24.6 | 23.5 | 556 | 0.02 | 3.4 | PCB1408TE |
| HS 14/08 | H 41408UG | 20.6 | 21.0 | 19.2 | 433 | 0.02 | 2.6 | PCB1408TE |
| RS 14/08 | S 41408UG | 20.2 | 23.0 | 19.2 | 460 | 0.02 | 2.8 | PCB1408TE |
| DS 18/11 | D 41811UG | 29.1 | 40.0 | 36.3 | 1,167 | 0.07 | 7.1 | PCB181111 |
| HS 18/11 | H 41811UG | 28.7 | 37.2 | 31.0 | 1,070 | 0.05 | 6.6 | PCB181111 |
| RS 18/11 | S 41811UG | 27.2 | 40.6 | 32.9 | 1,110 | 0.07 | 6.8 | PCB181111 |
| DS 23/11 | D 42311UG | 26.8 | 51.2 | 37.8 | 1,370 | 0.08 | 10.0 | PCB2311TA |
| HS 23/11 | H 42311UG | 27.0 | 48.2 | 37.8 | 1,300 | 0.08 | 9.1 | PCB2311TA |
| RS 23/11 | S 42311UG | 28.6 | 61.0 | 53.6 | 1,740 | 0.10 | 10.5 | PCB2311TA |
| DS 23/18 | D 42318UG | 39.9 | 58.0 | 40.7 | 2,310 | 0.21 | 13.0 | PCB2318TA |
| HS 23/18 | H 42318UG | 40.1 | 53.4 | 40.7 | 2,130 | 0.20 | 12.1 | PCB2318TA |
| RS 23/18 | S 42318UG | 41.6 | 62.2 | 53.6 | 2,590 | 0.22 | 14.0 | PCB2318TA |
| DS 26/16 | D 42616UG | 38.9 | 77.0 | 62.7 | 3,000 | 0.32 | 15.0 | PCB261611 |
| HS 26/16 | H 42616UG | 39.0 | 72.1 | 62.7 | 2,810 | 0.30 | 14.4 | PCB261611 |
| RS 26/16 | S 42616UG | 38.3 | 82.6 | 62.7 | 3,180 | 0.35 | 15.5 | PCB261611 |
| DS 30/19 | D 43019UG | 49.5 | 120 | 111 | 5,940 | 0.63 | 31.0 | PCB301911 |
| HS 30/19 | H 43019UG | 46.1 | 111 | 96.0 | 5,110 | 0.60 | 26.0 | PCB301911 |
| RS 30/19 | S 43019UG | 45.6 | 123 | 96.0 | 5,610 | 0.67 | 30.5 | PCB301911 |
| DS 36/22 | D 43622UG | 56.9 | 162 | 140 | 9,250 | 1.22 | 47.6 | PCB362211 |
| HS 36/22 | H 43622UG | 57.6 | 157 | 140 | 9,030 | 1.19 | 46.3 | PCB362211 |
| RS 36/22 | S 43622UG | 55.4 | 179 | 140 | 9,944 | 1.36 | 51.0 | PCB362211 |
| DS 42/29 | D 44229UG | 76.0 | 232 | 211 | 17,600 | 3.22 | 90.5 | PCB4229L1 |
| RS 42/29 | S 44229UG | 72.3 | 244 | 211 | 17,641 | 3.35 | 90.6 | PCB4229L1 |

Refer to page 62 for additional hardware information.

| TYPE/SIZE | ORDERING CODE | DIMENSIONS (mm) | | | | | | | | | |
|-----------|------------------|-----------------|----------------|----------------|--------------|-------------|-------------|--------------|-------------|-----------|------------|
| | | A | B | 2B | C | D | 2D | E | F | G | H |
| DS 14/08 | D 41408UG | 14.05 ± 0.25 | 4.15 ± 0.08 | 8.3 ± 0.15 | 9.4 ± 0.15 | 2.9 ± 0.1 | 5.8 ± 0.2 | 11.8 ± 0.2 | 5.9 ± 0.1 | 7.6 min | |
| HS 14/08 | H 41408UG | 14 ± 0.25 | 4.24 + 0/-0.13 | 8.48 + 0/-0.26 | 9.4 ± 0.15 | 2.8 min | 5.58 min | 11.6 min | 5.99 max | 7.6 min | 3.1 ± 0.1 |
| RS 14/08 | S 41408UG | 14 ± 0.25 | 4.24 + 0/-0.13 | 8.48 + 0/-0.26 | 9.4 ± 0.15 | 2.8 min | 5.58 min | 11.6 min | 5.99 max | 7.6 min | 3.1 ± 0.1 |
| DS 18/11 | D 41811UG | 18 ± 0.4 | 5.3 | 10.6 ± 0.15 | 11.9 ± 0.2 | 3.7 | 7.4 ± 0.2 | 15.15 ± 0.25 | 7.45 ± 0.15 | 11.2 min | |
| HS 18/11 | H 41811UG | 18 ± 0.4 | 5.3 ± 0.07 | 10.6 ± 0.15 | 11.9 ± 0.2 | 3.7 ± 0.1 | 7.4 ± 0.2 | 15.15 ± 0.25 | 7.45 ± 0.15 | 11.2 min | 3.1 ± 0.1 |
| RS 18/11 | S 41811UG | 18 ± 0.4 | 5.3 ± 0.07 | 10.6 ± 0.15 | 11.9 ± 0.2 | 3.7 ± 0.1 | 7.4 ± 0.2 | 15.15 ± 0.25 | 7.45 ± 0.15 | 11.2 min | 3.1 ± 0.1 |
| DS 23/11 | D 42311UG | 22.86 ± 0.46 | 5.54 ± 0.13 | 11.08 ± 0.26 | 15.24 ± 0.25 | 3.63 min | 7.26 min | 17.93 min | 9.9 max | 13.21 min | |
| HS 23/11 | H 42311UG | 22.86 ± 0.46 | 5.54 ± 0.13 | 11.08 ± 0.26 | 15.24 ± 0.25 | 3.63 min | 7.26 min | 17.93 min | 9.9 max | 13.21 min | 5.1 ± 0.1 |
| RS 23/11 | S 42311UG | 22.9 ± 0.45 | 5.5 ± 0.13 | 11 ± 0.25 | 15.2 ± 0.25 | 3.75 ± 0.13 | 7.5 ± 0.25 | 18.3 ± 0.35 | 9.7 ± 0.2 | 13.2 min | 5.1 ± 0.1 |
| DS 23/18 | D 42318UG | 22.86 ± 0.46 | 9 ± 0.18 | 18 ± 0.36 | 15.24 ± 0.25 | 6.93 min | 13.86 min | 17.93 min | 9.9 max | 13.21 min | |
| HS 23/18 | H 42318UG | 22.86 ± 0.46 | 9 ± 0.18 | 18 ± 0.36 | 15.24 ± 0.25 | 6.93 min | 13.86 min | 17.93 min | 9.9 max | 13.2 min | 5.08 ± 0.1 |
| RS 23/18 | S 42318UG | 22.9 ± 0.45 | 9 ± 0.18 | 18 ± 0.35 | 15.25 ± 0.25 | 7.2 ± 0.18 | 14.4 ± 0.35 | 18.3 ± 0.35 | 9.7 ± 0.2 | 13.2 min | 5.1 ± 0.1 |
| DS 26/16 | D 42616UG | 25.5 ± 0.51 | 8.05 ± 0.1 | 16.1 ± 0.2 | 17.09 nom | 5.51 min | 11.02 min | 21.21 min | 11.48 max | 15.5 min | |
| HS 26/16 | H 42616UG | 25.5 ± 0.51 | 8.05 ± 0.1 | 16.1 ± 0.2 | 17.09 nom | 5.51 min | 11.02 min | 21.21 min | 11.48 max | 15.5 min | 5.56 ± 0.1 |
| RS 26/16 | S 42616UG | 25.5 ± 0.51 | 8.05 ± 0.1 | 16.1 ± 0.2 | 17.09 nom | 5.51 min | 11.02 min | 21.21 min | 11.48 max | 15.5 min | 5.56 ± 0.1 |
| DS 30/19 | D 43019UG | 30 ± 0.51 | 9.4 ± 0.1 | 18.8 ± 0.2 | 20.3 ± 0.25 | 6.5 min | 13 min | 25 min | 13.51 max | 15.49 min | |
| HS 30/19 | H 43019UG | 30 ± 0.51 | 9.4 ± 0.1 | 18.8 ± 0.2 | 20.32 ± 0.25 | 6.5 min | 13 min | 25 min | 13.51 max | 15.49 min | 5.56 ± 0.1 |
| RS 30/19 | S 43019UG | 30 ± 0.51 | 9.4 ± 0.1 | 18.8 ± 0.2 | 20.32 ± 0.25 | 6.5 min | 13 min | 25 min | 13.51 max | 15.49 min | |
| DS 36/22 | D 43622UG | 35.61 ± 0.51 | 10.85 ± 0.12 | 21.7 ± 0.25 | 23.85 nom | 7.29 min | 14.58 min | 29.9 min | 16.1 max | 20.3 min | |
| HS 36/22 | H 43622UG | 35.61 ± 0.51 | 10.85 ± 0.12 | 21.7 ± 0.25 | 23.85 nom | 7.29 min | 14.58 min | 29.85 min | 16.1 max | 20.3 min | 5.56 ± 0.1 |
| RS 36/22 | S 43622UG | 35.61 ± 0.51 | 10.9 ± 0.07 | 21.8 ± 0.15 | 23.85 nom | 7.4 ± 0.1 | 14.8 ± 0.2 | 29.9 min | 16.1 max | 20.3 min | |
| DS 42/29 | D 44229UG | 42.4 ± 0.71 | 14.8 ± 0.2 | 29.6 ± 0.4 | 28.4 nom | 10.21 min | 20.42 min | 35.61 min | 17.7 max | 25.0 min | |
| RS 42/29 | S 44229UG | 42.4 ± 0.71 | 14.8 ± 0.2 | 29.6 ± 0.4 | 28.4 nom | 10.21 min | 20.42 min | 35.61 min | 17.7 max | 25.0 min | 5.56 ± 0.1 |

PQ Cores

PQ cores are designed specifically for switched mode power supplies. One result is an optimized ratio of volume to winding area and surface area, meaning that maximum inductance and winding area are possible with a minimum core size. The cores provide maximum power output with minimum assembled transformer weight and volume, in addition to taking up a minimum amount of area on the printed circuit board.

Assembly with printed circuit bobbins and one piece clamps is simplified. PQs provide a more uniform cross-sectional area, so they tend to operate with less pronounced hot spots than most other cores.

Typical applications include power transformers and power inductors.

| TYPE/SIZE | ORDERING CODE | NOMINAL A_L (mH/1000T) | | | | |
|-----------|------------------|--------------------------|-------|-------|-------|-------|
| | | L | R | P | F | T |
| PQ 20/16 | 0_42016UG | 1,650 | 3,587 | 3,907 | 4,690 | 4,080 |
| PQ 20/20 | 0_42020UG | 1,300 | 2,947 | 3,213 | 3,860 | 3,580 |
| PQ 26/10 | 0_42610UG | 3,900 | 7,733 | 8,413 | 8,080 | |
| PQ 26/14 | 0_42614UG | 2,700 | 5,613 | 6,113 | 7,335 | |
| PQ 26/20 | 0_42620UG | 2,640 | 5,560 | 6,053 | 7,270 | 7,020 |
| PQ 26/25 | 0_42625UG | 2,200 | 4,600 | 5,000 | 6,010 | 6,010 |
| PQ 32/12 | 0_43214UG | | 6,867 | 7,467 | 8,960 | |
| PQ 32/20 | 0_43220UG | | 6,640 | 7,213 | 8,875 | 7,560 |
| PQ 32/30 | 0_43230UG | | 4,667 | 5,080 | 6,100 | 6,570 |
| PQ 35/35 | 0_43535UG | | 4,813 | 5,240 | 7,347 | 6,000 |
| PQ 40/40 | 0_44040UG | | 4,267 | 4,640 | 5,580 | 6,100 |
| PQ 50/50 | 0_45050UG | | 7,400 | 8,195 | 9,639 | 9,200 |

HOW TO ORDER

OR 4 20 16 UG

Shape code ←
 Ferrite core material ←
 Used for all ferrite types ←
 Approximate length in mm ←
 Approximate height (per set) in mm ←
 Geometry code ←

PQ cores are sold in sets.
 For clip slot dimensions see individual data sheets.
 See page 19 for information on gapped cores.

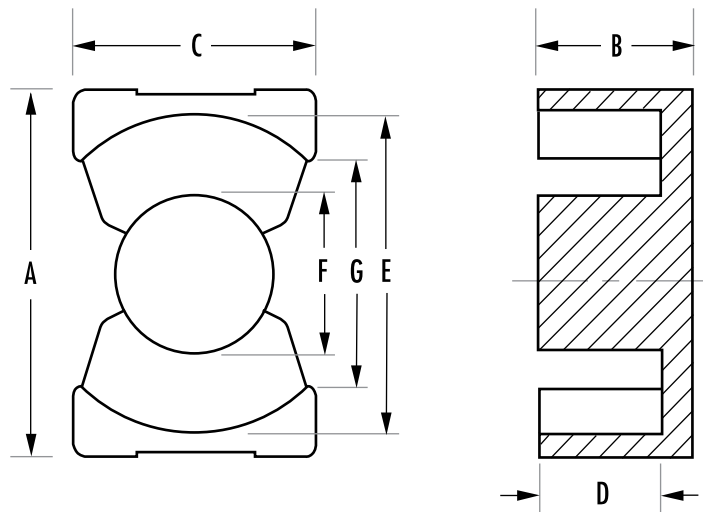



| | | MAGNETIC DATA | | | | | | HARDWARE |
|-----------|------------------|---------------|-----------------------------|---------------------------------|-----------------------------|----------------------------|---------------------------|-----------|
| TYPE/SIZE | ORDERING CODE | I_e (mm) | A_e (mm ²) | A_e min (mm ²) | V_e (mm ³) | WaAc (cm ⁴) | Weight (grams per set) | Bobbins |
| PQ 20/16 | 0_42016UG | 37.6 | 61.9 | 59.1 | 2,330 | 0.17 | 13 | PCB2016FC |
| PQ 20/20 | 0_42020UG | 45.7 | 62.6 | 59.1 | 2,850 | 0.23 | 16 | PCB2020FB |
| PQ 26/10 | 0_42610UG | 29.4 | 105 | 93.8 | 3,090 | 0.07 | 17 | |
| PQ 26/14 | 0_42614UG | 33.3 | 86.4 | 70.9 | 2,880 | 0.17 | 16 | |
| PQ 26/20 | 0_42620UG | 45.0 | 121 | 109 | 5,470 | 0.40 | 31 | PCB2620LB |
| PQ 26/25 | 0_42625UG | 54.3 | 120 | 108 | 6,530 | 0.60 | 36 | PCB2625LB |
| PQ 32/12 | 0_43214UG | 34.4 | 109 | 92.0 | 3,750 | 0.29 | 21 | |
| PQ 32/20 | 0_43220UG | 55.9 | 169 | 142 | 9,440 | 0.79 | 42 | PCB3220B1 |
| PQ 32/30 | 0_43230UG | 74.7 | 167 | 142 | 12,500 | 1.66 | 57 | PCB3230B1 |
| PQ 35/35 | 0_43535UG | 86.1 | 190 | 162 | 16,300 | 3.02 | 73 | PCB3535LB |
| PQ 40/40 | 0_44040UG | 102 | 201 | 175 | 20,500 | 4.84 | 97 | PCB4040FA |
| PQ 50/50 | 0_45050UG | 113 | 328 | 314 | 37,100 | 8.28 | 195 | 00B5050B1 |

Refer to page 62 for additional hardware information.

| | | DIMENSIONS (mm) | | | | | | | | |
|-----------|------------------|-----------------|--------------|-------------|-------------|--------------|------------|-------------|-------------|------------|
| TYPE/SIZE | ORDERING CODE | A | B | 2B | C | D | 2D | E | F | G |
| PQ 20/16 | 0_42016UG | 21.3 ± 0.4 | 8.1 ± 0.1 | 16.2 ± 0.2 | 14.0 ± 0.4 | 5.15 ± 0.15 | 10.3 ± 0.3 | 18.0 ± 0.4 | 8.8 ± 0.2 | 12.0 min |
| PQ 20/20 | 0_42020UG | 21.3 ± 0.4 | 10.1 ± 0.1 | 20.2 ± 0.2 | 14.0 ± 0.4 | 7.15 ± 0.15 | 14.3 ± 0.3 | 18.0 ± 0.4 | 8.8 ± 0.2 | 12.0 min |
| PQ 26/10 | 0_42610UG | 27.2 ± 0.45 | 5.1 ± 0.1 | 10.2 ± 0.2 | 19.0 ± 0.45 | 1.2 min | 2.39 min | 22.05 min | 12.2 max | 15.5 min |
| PQ 26/14 | 0_42614UG | 27.2 ± 0.45 | 5.94 ± 0.1 | 11.9 ± 0.2 | 19.0 ± 0.45 | 3.4 min | 6.7 min | 22.05 min | 12.2 max | 15.5 min |
| PQ 26/20 | 0_42620UG | 27.3 ± 0.46 | 10.1 ± 0.13 | 20.2 ± 0.25 | 19.0 ± 0.45 | 5.75 ± 0.15 | 11.5 ± 0.3 | 22.5 ± 0.45 | 12.0 ± 0.2 | 15.5 min |
| PQ 26/25 | 0_42625UG | 27.3 ± 0.46 | 12.35 ± 0.13 | 24.7 ± 0.25 | 19.0 ± 0.45 | 8.05 ± 0.15 | 16.1 ± 0.3 | 22.5 ± 0.46 | 12.0 ± 0.2 | 15.5 min |
| PQ 32/12 | 0_43214UG | 33.0 ± 0.5 | 5.94 ± 0.1 | 11.9 ± 0.2 | 22.0 ± 0.5 | 3.4 min | 6.7 min | 27.0 min | 13.75 max | 19.0 min |
| PQ 32/20 | 0_43220UG | 33.0 ± 0.5 | 10.3 ± 0.13 | 20.6 ± 0.25 | 22.0 ± 0.5 | 5.75 ± 0.15 | 11.5 ± 0.3 | 27.5 ± 0.5 | 13.5 ± 0.25 | 19.0 min |
| PQ 32/30 | 0_43230UG | 33.0 ± 0.5 | 15.15 ± 0.13 | 30.3 ± 0.25 | 22.0 ± 0.5 | 10.65 ± 0.15 | 21.3 ± 0.3 | 27.5 ± 0.5 | 13.5 ± 0.25 | 19.0 min |
| PQ 35/35 | 0_43535UG | 36.1 ± 0.6 | 17.35 ± 0.13 | 34.7 ± 0.25 | 26.0 ± 0.5 | 12.5 ± 0.15 | 25.0 ± 0.3 | 32.0 ± 0.5 | 14.4 ± 0.25 | 23.5 min |
| PQ 40/40 | 0_44040UG | 41.5 ± 0.9 | 19.9 ± 0.15 | 39.8 ± 0.3 | 28.0 ± 0.6 | 14.75 ± 0.2 | 29.5 ± 0.4 | 37.0 ± 0.6 | 14.9 ± 0.3 | 29.0 ± 1.0 |
| PQ 50/50 | 0_45050UG | 51.0 ± 0.7 | 25.0 ± 0.25 | 50.0 ± 0.5 | 32.0 ± 0.6 | 18.05 ± 0.3 | 36.1 ± 0.6 | 44.0 ± 0.7 | 20.0 ± 0.35 | 32.0 min |

RM Cores

RM cores are designed for wound assemblies with a square footprint for efficient use of PC board space. The wire openings allow space for multiple coil terminations and offer a balance between shielding and thermal performance.

Easy to assemble and adaptable to automation, completed units provide at least 40% savings in mounting area compared to a similar size pot core assembly.

Typical applications include differential mode inductors, power inductors, filter inductors, telecom inductors and broadband transformers.

| TYPE/SIZE | ORDERING CODE | NOMINAL A_L (mH/1000T) | | | | | | | | |
|-----------|------------------|--------------------------|-------|-------|-------|-------|--------|--------|-----|-------|
| | | L | R | P | F | T | J | W | C | V |
| RM 4 N | N_41110UG | 560 | 1,125 | 1,191 | 1,333 | | 1,752 | 3,518 | | |
| RM 4 | R_41110UG | | 920 | 1,000 | 1,200 | | 1,973 | 3,000 | | |
| RM 5 N | N_41510UG | 900 | 1,720 | 1,867 | 2,100 | | 4,133 | 6,000 | | |
| RM 5 | R_41510UG | | 1,720 | 1,867 | 2,100 | | 4,133 | 6,000 | 800 | 1,960 |
| RM 6R N | N_41812UG | 1,230 | 2,387 | 2,600 | 3,080 | 2,830 | 6,707 | 8,600 | | |
| RM 6R | R_41812UG | | 2,187 | 2,333 | 2,800 | | 5,973 | 7,714 | | 2,700 |
| RM 6S N | N_41912UG | 1,250 | 2,213 | 2,400 | 2,880 | | 6,000 | 8,600 | | |
| RM 6S | R_41912UG | | 1,987 | 2,160 | 2,600 | | 5,387 | 7,714 | | |
| RM 7 N | N_42013UG | 1,450 | 3,058 | 3,244 | 3,675 | | 5,001 | 9,571 | | |
| RM 8 N | N_42316UG | 1,700 | 2,700 | 2,933 | 5,210 | 4,100 | 8,000 | 12,200 | | |
| RM 8 | R_42316UG | | 2,347 | 2,560 | 3,500 | | 6,960 | 10,600 | | |
| RM 10 N | N_42819UG | 2,200 | 4,047 | 4,400 | 5,500 | 5,500 | 9,987 | 16,000 | | |
| RM 10 | R_42819UG | | | | 4,750 | | | | | |
| RM 12 N | N_43723UG | | 4,600 | 5,000 | 6,000 | 6,790 | 11,800 | 22,600 | | |
| RM 14 N | N_44230UG | | 7,000 | 7,540 | 8,782 | 8,130 | 13,096 | 20,735 | | |

HOW TO ORDER

R P 4 15 10 UG

Shape code ←
 Ferrite core material ←
 Used for all ferrite types ←
 Approximate diameter in mm ←
 Approximate height (per set) in mm ←
 Geometry code ←

SHAPE CODE

N — RM core with solid center post
 R — RM core with center hole

RM cores are sold in sets.
 See page 19 for information on gapped cores.

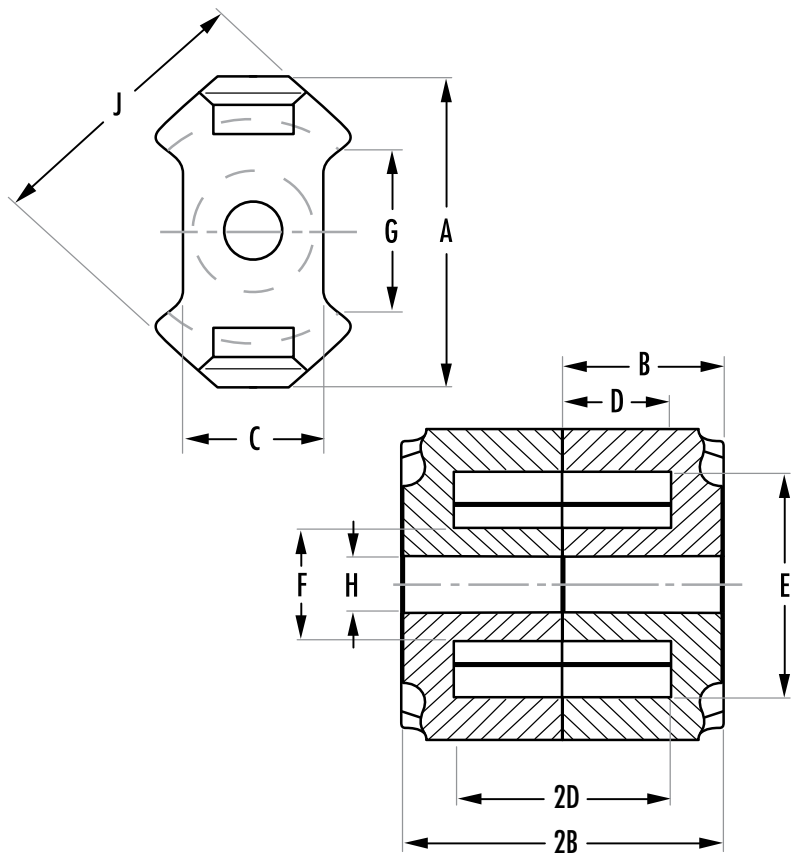



| TYPE/SIZE | ORDERING CODE | MAGNETIC DATA | | | | | | HARDWARE |
|-----------|------------------|------------------------|--------------------------------------|--|--------------------------------------|----------------------------|---------------------------|-----------|
| | | I _e (mm) | A _e (mm ²) | A _e min (mm ²) | V _e (mm ³) | WaAc (cm ⁴) | Weight (grams per set) | Bobbins |
| RM 4 N | N_41110UG | 23.3 | 13.8 | 11.5 | 322 | 0.01 | 1.7 | PCB11104B |
| RM 4 | R_41110UG | 20.6 | 10.8 | 7.9 | 222 | 0.01 | 1.5 | PCB11104B |
| RM 5 N | N_41510UG | 23.2 | 24.8 | 18.1 | 574 | 0.02 | 3.2 | PCB1510B1 |
| RM 5 | R_41510UG | 21.4 | 21.0 | 13.9 | 449 | 0.02 | 3.1 | PCB1510B1 |
| RM 6R N | N_41812UG | 27.5 | 38.0 | 31.2 | 1,040 | 0.06 | 5.4 | OOC1812B1 |
| RM 6R | R_41812UG | 25.6 | 32.0 | 22.6 | 819 | 0.05 | 4.5 | OOC1812B1 |
| RM 6S N | N_41912UG | 29.2 | 37.0 | 31.2 | 1,090 | 0.06 | 5.5 | |
| RM 6S | R_41912UG | 27.0 | 31.0 | 22.6 | 837 | 0.05 | 5.1 | |
| RM 7 N | N_42013UG | 30.0 | 44.1 | 39.6 | 1,325 | 0.17 | 7.5 | |
| RM 8 N | N_42316UG | 38.4 | 63.0 | 55.4 | 2,440 | 0.19 | 13 | OOC2316B1 |
| RM 8 | R_42316UG | 35.5 | 52.0 | 36.9 | 1,850 | 0.16 | 11 | OOC2316B1 |
| RM 10 N | N_42819UG | 44.6 | 96.6 | 89.1 | 4,310 | 0.44 | 22 | OOC2819B1 |
| RM 10 | R_42819UG | 41.7 | 83.2 | 65.3 | 3,470 | 0.41 | 18 | OOC2819B1 |
| RM 12 N | N_43723UG | 56.6 | 146 | 125 | 8,340 | 1.07 | 46 | PCB3723M1 |
| RM 14 N | N_44230UG | 70.0 | 198 | 168 | 13,900 | 1.73 | 69 | |

Refer to page 62 for additional hardware information.

| TYPE/SIZE | ORDERING CODE | DIMENSIONS (mm) | | | | | | | | | | |
|-----------|------------------|-----------------|------------|----------|-------------|-------------|-------------|--------------|-------------|----------|------------|-------------|
| | | A | B | 2B | C | D | 2D | E | F | G | H | J |
| RM 4 N | N_41110UG | 11.0+0/-0.5 | 5.2±0.05 | 10.4±0.1 | 4.6+0/-0.2 | 3.5+0.2/-0 | 7.0+0.4/-0 | 7.95+0.4/-0 | 3.9+0/-0.2 | 5.8 min | | 9.8+0/-0.4 |
| RM 4 | R_41110UG | 11.8 max | 5.2±0.05 | 10.4±0.1 | 4.45 nom | 3.61±0.1 | 7.21±0.2 | 8.15±0.2 | 3.8±0.1 | 5.79 ref | 2.05±0.05 | 9.6±0.2 |
| RM 5 N | N_41510UG | 14.6+0/-0.6 | 5.2±0.05 | 10.4±0.1 | 6.8+0/-0.4 | 3.25±0.1 | 6.5±0.2 | 10.2+0.4/-0 | 4.9+0/-0.2 | 6.0 min | | 12.3+0/-0.5 |
| RM 5 | R_41510UG | 14.9 max | 5.2±0.05 | 10.4±0.1 | 6.6 nom | 3.25±0.1 | 6.5±0.2 | 10.4±0.2 | 4.8±0.1 | 6.71 nom | 2.05±0.05 | 12.05±0.25 |
| RM 6R N | N_41812UG | 17.9+0/-0.7 | 6.2±0.05 | 12.4±0.1 | 7.4+0/-0.4 | 4.0+0.2/-0 | 8.0+0.4/-0 | 12.4+0.5/-0 | 6.4+0/-0.2 | 5.85 nom | | 14.7+0/-0.6 |
| RM 6R | R_41812UG | 18.3 max | 6.2±0.05 | 12.4±0.1 | 7.4 nom | 4.1±0.1 | 8.2±0.2 | 12.65±0.25 | 6.25±0.15 | 5.85 nom | 3.05±0.05 | 14.4±0.3 |
| RM 6S N | N_41912UG | 18.3 max | 6.2±0.05 | 12.4±0.1 | 8.2 nom | 4.1±0.1 | 8.2±0.2 | 12.65±0.25 | 6.25±0.15 | 9.0 nom | | 14.4±0.3 |
| RM 6S | R_41912UG | 18.3 max | 6.2±0.05 | 12.4±0.1 | 8.2 nom | 4.1±0.1 | 8.2±0.2 | 12.65±0.25 | 6.25±0.15 | 9.0 nom | 3.05±0.05 | 14.4±0.3 |
| RM 7 N | N_42013UG | 20.3+0/-0.8 | 6.7±0.05 | 13.4±0.1 | 7.25+0/-0.3 | 4.2+0.25/-0 | 8.4+0.5/-0 | 14.75+0.6/-0 | 7.25+0/-0.3 | 9.3 min | | 17.2+0/-0.7 |
| RM 8 N | N_42316UG | 23.2+0/-0.9 | 8.2±0.05 | 16.4±0.1 | 11.0+0/-0.5 | 5.5±0.1 | 11.0±0.2 | 17.0+0.6/-0 | 8.55+0/-0.3 | 9.5 min | | 19.7+0/-0.8 |
| RM 8 | R_42316UG | 23.2 max | 8.2±0.05 | 16.4±0.1 | 10.8 nom | 5.53±0.13 | 11.05±0.25 | 17.5±0.35 | 8.4±0.15 | 11.7 nom | 4.5±0.1 | 19.3±0.4 |
| RM 10 N | N_42819UG | 28.5+0/-1.3 | 9.3±0.05 | 18.6±0.1 | 13.5+0/-0.5 | 6.2+0.3/-0 | 12.4+0.6/-0 | 21.2+0.9/-0 | 10.9+0/-0.4 | 10.9 min | | 24.7+0/-1.1 |
| RM 10 | R_42819UG | 28.5+0/-1.3 | 9.3±0.05 | 18.6±0.1 | 13.5+0/-0.5 | 6.2+0.3/-0 | 12.4+0.6/-0 | 21.2+0.9/-0 | 10.9+0/-0.4 | 10.9 min | 5.4+0.2/-0 | 24.7+0/-1.1 |
| RM 12 N | N_43723UG | 37.4+0/-1.3 | 12.25±0.05 | 24.5±0.1 | 16.1+0/-0.5 | 8.4+0.3/-0 | 16.8+0.6/-0 | 24.9+1.1/-0 | 12.8+0/-0.4 | 12.9 min | | 29.8+0/-1.1 |
| RM 14 N | N_44230UG | 42.2+0/-1.4 | 15.05±0.05 | 30.1±0.1 | 19.0+0/-0.6 | 10.4+0.3/-0 | 20.8+0.6/-0 | 29.0+1.2/-0 | 15.0+0/-0.6 | 17.0 nom | | 34.8+0/-1.3 |

Hardware



| SIZE | TYPE | P/N | SIZE | TYPE | P/N | SIZE | TYPE | P/N | SIZE | TYPE | P/N | SIZE | TYPE | P/N | SIZE | TYPE | P/N |
|-------------|------|-----------|-------------|-------|-----------|-------------|-------|-----------|-------------|-------|-----------|-------------|-------|-----------|-------------|-------|-----------|
| 0200 | TC | SMC06018A | 1408 | PC | O0B140801 | 1912 | RM | PCB181241 | 2507 | TC | TVB2908TA | 3113 | TC | TVB2908TA | 4119 | EC | PCH411901 |
| | | SMH05025A | | RS/DS | O0B140802 | | | PCB181261 | | | TVH22064A | | | TVB3610FA | 4216 | EER | PCB4216FA |
| | | SMH07058A | | | O0C140811 | | | TBA181201 | | | TVH25074A | 3205 | TC | TVB3610FA | 4229 | PC | O0B422901 |
| 0301 | TC | SMC06018A | | | O0W140815 | | | TCA1812C2 | 2508 | TC | TVB2908TA | | | TVH38134A | | | O0B422902 |
| | | SMH05025A | | | PCB140821 | 2016 | PQ | O0C201612 | | | TVH22064A | 3208 | P-EC | O0C320802 | | | O0C422917 |
| | | SMH07058A | | | PCB1408S1 | | | PCB2016FC | | | TVH25074A | 3220 | PQ | O0C322017 | | | PCB4229L1 |
| 0401 | TC | SMC06018A | | | PCB1408TA | 2019 | EFD | O0C2019B1 | 2510 | EC | O0B251001 | | | PCB3220B1 | | | TBP669000 |
| | | SMH05025A | | | PCB1408TB | | | PCB2019B1 | | | PCB2510V1 | 3230 | PQ | O0C323017 | | | TCF2800B1 |
| | | SMH07058A | | | PCB1408TE | 2020 | PQ | O0C202012 | | | PCB2510V2 | | | PCB3230B1 | | | TCF4000B1 |
| 0402 | TC | SMC06018A | | | TBA140800 | | | PCB2020FC | 2515 | EC-EC | O0B251501 | 3434 | ETD | O0C343416 | 4317 | EC | PCB4317M1 |
| | | SMH05025A | | | TCA1408B1 | 2106 | TC | TVB22066A | 2520 | EC | PCB2520TA | | | PCB3434FB | | | O0B4317B1 |
| | | SMH07058A | | | TCA1408C3 | | | TVB2908TA | 2523 | EFD | O0C2523B1 | 3515 | EC | O0B351501 | 4416 | TC | TVH49164A |
| 0502 | TC | SMC06018A | 1450 | TC | TVB22066A | | | TVH22064A | | | PCB2523B1 | | | PCB3515M1 | 4444 | ETD | O0C444416 |
| | | SMH05025A | | | TVH22064A | 1506 | TC | TVB22066A | 2616 | PC | O0B261601 | | | PCB3515M2 | | | PCB444418 |
| | | SMH07058A | | | TVH22064A | | | TVH25074A | | RS/DS | O0B261602 | 3517 | EC | OAC351717 | 4715 | TC | TVH49164A |
| 0503 | TC | SMC06018A | | | TVH22064A | 2109 | TC | TVB22066A | | | O0B261603 | | | OCC351700 | 4721 | EC | PCB4721M1 |
| | | SMH05025A | | | TVH22064A | | | TVB2908TA | | | O0C261614 | | | PCB351701 | 4916 | TC | TVH49164A |
| | | SMH07058A | | | TVH22064A | | | TVH22064A | | | OPC261614 | | | PCH351701 | 4920 | TC | TVH49164A |
| 0601 | TC | SMC06018A | | | PCB1510B1 | 2120 | EP | OAC212016 | | | PCB261611 | 3521 | EER | PCB3521LA | 4925 | TC | TVH49164A |
| | | SMH07058A | | | TBP151000 | | | OBC212016 | 2206 | TC | PCB261612 | 3535 | PQ | O0C353517 | 4932 | TC | TVH49164A |
| 0603 | TC | SMC06018A | | | SMB1515TA | | | PCB2120VB | | | PCB261613 | 3610 | TC | PCB3535LB | 4949 | ETD | O0C494916 |
| | | SMH07058A | | | O0C1515B1 | 2206 | TC | TVB22066A | | | PCB261621 | 3615 | TC | TVH38134A | | | PCB494920 |
| | | SMH07058A | | | PCB1515B1 | | | TVB2908TA | | | PCB261622 | 3622 | PC | TVH38134A | | | PCB4949WA |
| 0704 | PC | O0B070401 | 1605 | TC | TVB22066A | | | TVH22064A | | | PCB2616TA | | | TVH38134A | 5050 | PQ | O0B5050B1 |
| | | O0B0704B1 | | | TVH22064A | 2207 | TC | TVB22066A | 2620 | PQ | TBP669000 | | | O0B362201 | 5224 | EC | OAC522423 |
| 0705 | TC | SMH07058A | | | TVH22064A | | | TVH25074A | | | TCF2800B1 | 3622 | PC | O0C362217 | | | OCC522400 |
| 0707 | EP | OAC070716 | 1717 | EP | O0C17172A | | | TVB2908TA | 2625 | PQ | O0C262012 | | | PCB362211 | | | PCB522401 |
| | | OBC070712 | | | PCB17178A | | | TVH22064A | | | PCB2620LB | | | PCB3622L1 | | | PCH522401 |
| | | SMB07076A | | | O0C180520 | 2207 | TC | TVB22066A | | | O0C262512 | | | TBP669000 | | | O0B5224B1 |
| 0905 | PC | O0B090501 | 1805 | P-EC | O0C180520 | | | TVB2908TA | 2625 | PQ | PCB2625LB | | | TCF2800B1 | 5454 | ETD | O0C5454B1 |
| 0906 | ER | O0C09061A | 1808 | EC | O0B180801 | | | TVH22064A | | | PCB2625LB | | | TCF4000B1 | | | PCB5454B1 |
| | | SMB09068A | | | PCB1808B1 | 2212 | TC | TVB22066A | 2819 | PC | O0C2819B1 | | | TCF4000B1 | | | PCB5454B1 |
| 1009 | EFD | O0C1009B1 | 1809 | TC | TVB22066A | | | TVH22064A | 2823 | PC | O0B282301 | 3723 | RM | PCB3723M1 | 5528 | EC | O0B5528B1 |
| | | PCB1009B1 | | | TVH22064A | | | TVH25074A | 2908 | TC | TVB2908TA | 3806 | TC | TVB3610FA | | | PCB5528WC |
| 1010 | EP | O0C10102A | 1811 | PC | O0B181101 | 2213 | PC | O0B221301 | | | TVB3610FA | | | TVH38134A | 5530 | EC | PCB5530FA |
| | | PCB10108A | | RS/DS | O0B181102 | | | O0B221302 | | | TVH25074A | 3813 | TC | TVB3610FA | 5724 | EC | O0B5724B1 |
| | | SMB10108A | | | O0C181103 | | | O0B221303 | | | TVB2908TA | | | TVH38134A | | | PCB5724M1 |
| 1107 | PC | O0B1107B1 | | | O0C181111 | | | O0C221314 | 2915 | TC | TVB2908TA | | | TVH49164A | 5810 | EC-IC | O0C581001 |
| | | O0B1107A2 | | | O0W181118 | | | O0W221324 | | | TVB3610FA | | | TVH49164A | | | O0C581002 |
| | | O0C1107B1 | | | PCB181111 | | | OPC221314 | 2929 | ETD | TVH25074A | | | TVH38134A | 5959 | ETD | O0C595916 |
| 1110 | RM | O0C1110B1 | | | PCB181112 | | | PCB221311 | | | O0C2929B1 | | | TVH49164A | | | PCB5959AA |
| 1212 | EFD | O0C1212B1 | | | PCB181121 | | | PCB221321 | 3007 | EC | PCB3007T1 | 3939 | ETD | O0C393916 | 6113 | TC | TVH49164A |
| | | PCB1212B1 | | | PCB181122 | | | TCF2213B1 | 3009 | EC | PCB3009LA | | | PCB3939SB | | | TVH61134A |
| 1313 | EP | OAC131316 | 1812 | RM | O0C1812B1 | | | O0C221620 | 3019 | PC | O0B301901 | 4015 | TC | TVH49164A | 6326 | TC | TVH49164A |
| | | OBC131314 | | | TBA181201 | | | PCB2311TA | | RS/DS | O0B301902 | 4020 | EC-IC | O0B402021 | | | TVH61134A |
| | | PCB1313B1 | | | TCA1812C2 | 2316 | | O0C2316B1 | | | O0B301903 | 4022 | EC | PCB4020N1 | 6410 | EC-IC | O0C641001 |
| | | SMB1313B1 | | | | 2318 | RS/DS | PCB2318TA | | | O0C301917 | 4040 | PQ | PCB4022N1 | | | O0C641002 |
| 1406 | TC | TVB22066A | | | | | | | | | PCB301911 | | | PCB404017 | 6527 | EC | O0B652701 |
| | | TVH22064A | | | | | | | | | PCB301921 | | | PCB4040FA | 7035 | EC | O0B703501 |
| 1407 | TC | TVB22066A | | | | | | | | | PCB3019TA | | | O0B411901 | | | PCB703501 |
| | | TVH22064A | | | | | | | | | TBP669000 | | | OAC411919 | | | PCH703501 |
| | | | | | | | | | | | TCF2800B1 | | | OCC411900 | 7228 | EC | O0B722801 |
| | | | | | | | | | | | O0C3030B1 | | | PCB411901 | 8020 | EC | O0B8020B1 |
| | | | | | | | | | | | PCB3030B1 | | | | | | |

Power Design

Ferrite is an ideal core material for transformers, inverters and inductors in the frequency range 20 kHz to 3 MHz, due to the combination of low core cost and low core losses. Ferrites may be used in the saturating mode for low power, low frequency operation (<50 watts and 10 kHz). Ferrite cores may also be used in flyback transformer designs, which offer low core cost, low circuit cost and high voltage capability. Powder cores (MPP, High Flux, Edge[®], Kool Mu[®], Kool Mu[®] MAX, Kool Mu[®] Hf, and XFlux[®]) offer soft saturation, higher B_{max} , and superior temperature stability and are often the best choice for minimum size and robust performance in power choke, inductor, and flyback applications.

CORE GEOMETRIES

POT CORES

Pot cores, when assembled, nearly surround the wound bobbin. This aids in shielding the coil from pickup of EMI from outside sources. The pot core dimensions follow IEC standards so that there is interchangeability between manufacturers. Both plain and printed circuit bobbins are available, as are mounting and assembly hardware.

ROUND SLAB, DOUBLE SLAB & RM CORES

Slab-sided solid center post cores resemble pot cores, but have a section cut off on either side of the skirt. The additional openings allow larger wires to be accommodated and assist in removing heat from the assembly. RM cores are also similar to pot cores, but are designed to minimize board space, providing at least a 40% savings in mounting area. Printed circuit or plain bobbins are available. One-piece clamps permit simple assembly. Low profile is possible. The solid center post generates less core loss and minimizes heat buildup.

PQ CORES

PQ cores are designed specifically for switched mode power supplies. One result is an optimized ratio of volume to winding area and surface area, meaning that maximum inductance and winding area are possible with a minimum core size. The cores provide maximum power output with minimum assembled transformer weight and volume, in addition to taking up a minimum amount of area on the printed circuit board.

Assembly with printed circuit bobbins and one piece clamps is simplified. PQs provide a more uniform cross-sectional area, so they tend to operate with less pronounced hot spots than most other cores.

EC, ETD AND EER CORES

These shapes combine the benefits of E cores and pot cores. Like E cores, they have a wide opening on each side. This provides ample space for the large wires used for low output voltage switched mode power supplies. It also increases the flow of air which keeps the assembly cooler. The center leg is round, like that of the pot core. One of the advantages of the round center leg is that the winding has a shorter path length around it (11% shorter) than the wire around a square center leg with an equal area. This reduces the losses of the windings by 11% and

enables the core to handle a higher output power. The round center leg eliminates the sharp bend in the wire that occurs with winding on a square center leg.

E, ER AND PLANAR E CORES

E cores offer the advantage of simple bobbin winding and ease of assembly. A wide variety of standard lamination-size, metric and DIN sizes are available. E cores are a low-cost choice in designs that do not require self-shielding. Planar cores are the best selection for low profile applications. Copper traces that are layered in the printed circuit board are the windings in most planar applications. This type of design provides superior thermal characteristics, economical assembly, low leakage inductance, and consistent performance.

EP CORES

EP cores are round center post cubical shapes which enclose the coil completely except for the printed circuit board terminals. The particular shape minimizes the effect of air gaps formed at mating surfaces in the magnetic path and provides a larger volume ratio to total space used. Shielding is excellent.

TOROIDS

Toroids are the least expensive ferrite shape. Available in a variety of sizes, outer diameters of 2.54 mm – 140 mm, toroids have good self-shielding properties. The fact that the core is a solid with no sections to assemble makes it a good choice if mechanical integrity is important in a high vibration environment. Toroid cores are available uncoated or with an epoxy, nylon or Parylene coating.

CORE MATERIALS

POWER

Magnetics R, P, F, T and L materials provide superior saturation, high temperature performance, low losses and product consistency.

T material is ideal for consistent performance over a wide temperature range. Applications for T include: Automotive, Electronic Lighting, Outdoor LCD Screens, Mobile Handheld Devices and AC adapters and chargers.

L material was formulated for high-frequency and high-temperature applications. L is designed for DC-DC converters, filters and power supplies that operate from 0.5 – 3.0 Mhz. Curie temperature is high for a ferrite material at 280°C.

R material is an economical, low-loss choice for a broad range of applications.

P material offers similar properties to R material, but is more readily available in some sizes.

F material is an established material with a relatively high permeability and 210°C Curie temperature.

Power Supplies, DC-DC Converters, Handheld Devices, High Power Control (gate drive) and EMI Filters are just a few of the applications that are typical for Magnetics ferrite power materials.

FILTER

Magnetics high permeability materials are engineered for optimum frequency and impedance performance in signal, choke and filter applications.

J and W materials offer high impedance for broadband transformers and are suitable for low-level power transformers.

J material is a medium perm, general-purpose material.

J's properties are well suited both for EMI/RFI filtering and broadband transformers.

W material has set the industry standard for high perm materials. In filter applications, W perm has 20-50% more impedance below 1 MHz than J perm.

M material is Magnetics' highest permeability material at 15,000 μ . Applications for M include: EMI/RFI suppression filters, common mode chokes, signal processing, and broadband transformers.

LINEAR FILTERS AND SENSORS

Magnetics **C**, **E** and **V materials** offer excellent properties for low-level signal applications. These materials set the standard for high quality factor, long-term stability and precise and adjustable inductance. Applications for these materials include high Q filters, wideband transformers, pulse transformers and RLC tuned circuits.

Inductor Design

Ferrite E cores and pot cores offer the advantages of decreased cost and low core losses at high frequencies. For switching regulators, power materials are recommended because of their temperature and DC bias characteristics. By adding air gaps to these ferrite shapes, the cores can be used efficiently while avoiding saturation.

These core selection procedures simplify the design of inductors for switching regulator applications. One can determine the smallest core size, assuming a winding factor of 50% and wire current carrying capacity of 500 circular mils per ampere.

Only two parameters of the design applications must be known:

- (a) Inductance required with DC bias
- (b) DC current

1. Compute the product of Ll^2 where:
 - L = inductance required with DC bias (millihenries)
 - I = maximum DC output current + 1/2 AC Ripple
2. Locate the Ll^2 value on the Ferrite Core Selector charts shown. Follow this coordinate up to the intersection with the first core size curve. Read the maximum nominal inductance, A_L , on the Y-axis. This represents the smallest core size and maximum A_L at which saturation will be avoided.
3. Any core size line that intersects the Ll^2 coordinate represents a workable core for the inductor if the core's A_L value is less than the maximum value obtained on the chart.
4. Required inductance L , core size, and core nominal inductance (A_L) are known. Calculate the number of turns using

$$N = 10^3 \sqrt{\frac{L}{A_L}}$$

where L is in millihenries.

5. Example: If $I_{MAX} = 8$ Amps; L , inductance required = 100 μ Henries
 $Ll^2 = (0.100 \text{ mH}) \times (8^2 \text{ Amps}) = 6.4$ millijoules
6. There are many ferrite cores available that will support the energy required. Any core size that the Ll^2 coordinate intersects can be used at the A_L value shown on the chart.
7. Some choices based upon an Ll^2 value of 6.4 millijoules are:

| | | | |
|----------------|-------------|-------------------|-------------|
| Pot core 43622 | $A_L = 400$ | Double Slab 43622 | $A_L = 250$ |
| PQ core 43220 | $A_L = 300$ | E core 44317 | $A_L = 250$ |
8. For the following A_L values the number of turns required is:

| | | |
|------------------------|------------------------|------------------------|
| $A_L = 400$, $N = 16$ | $A_L = 300$, $N = 19$ | $A_L = 250$, $N = 20$ |
|------------------------|------------------------|------------------------|

 Make sure the wire size chosen will support the current and fit into the core set.

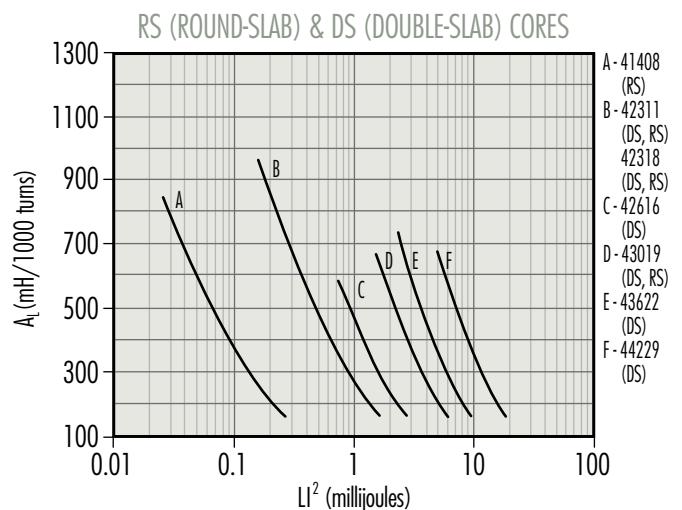
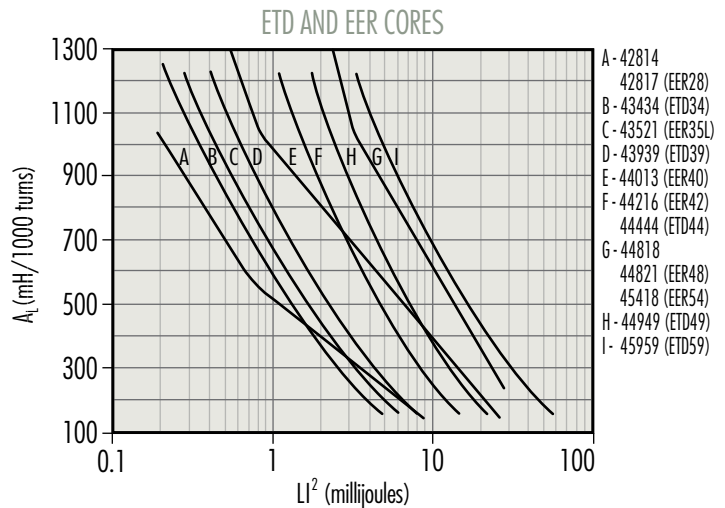
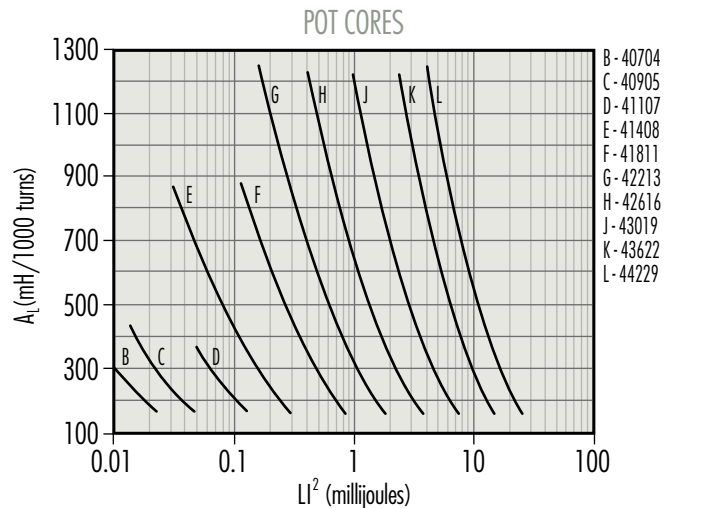

Inductor Design

RM AND EP CORES

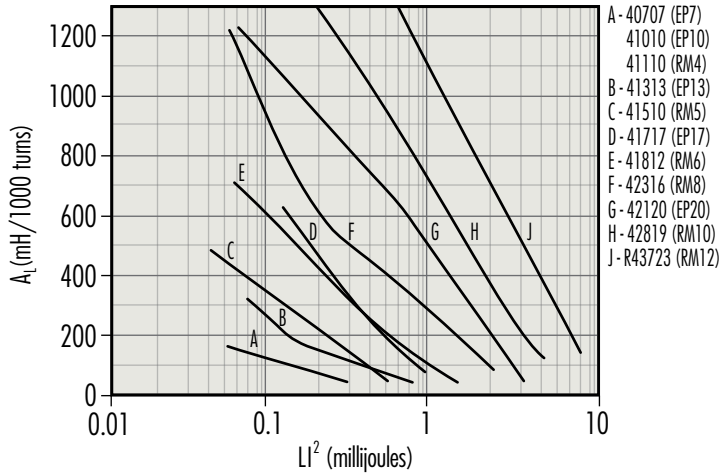

PQ CORES

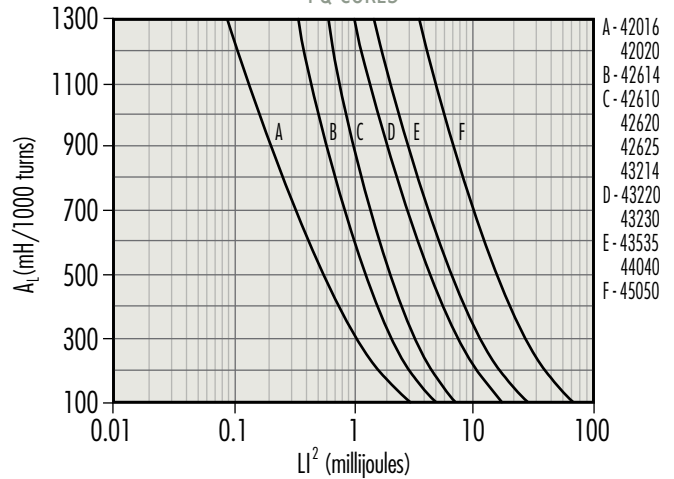

LAMINATION SIZE E CORES

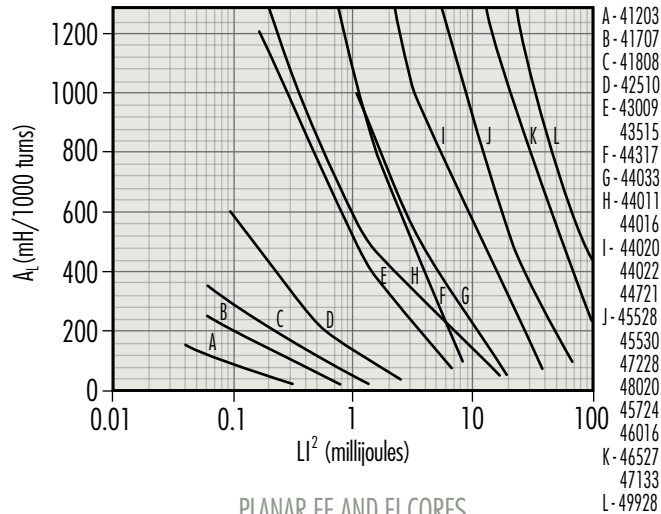

E CORES

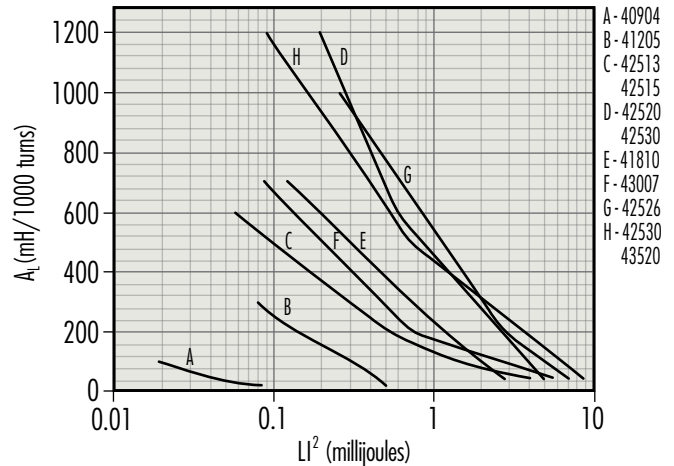

PLANAR EE AND EI CORES

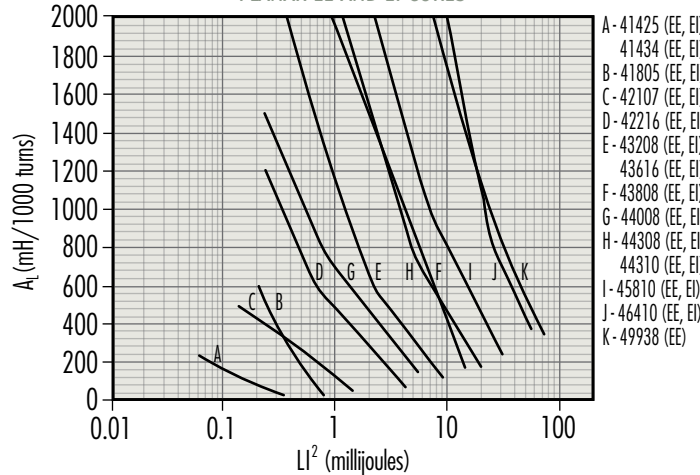

ER, EFD, AND EC CORES

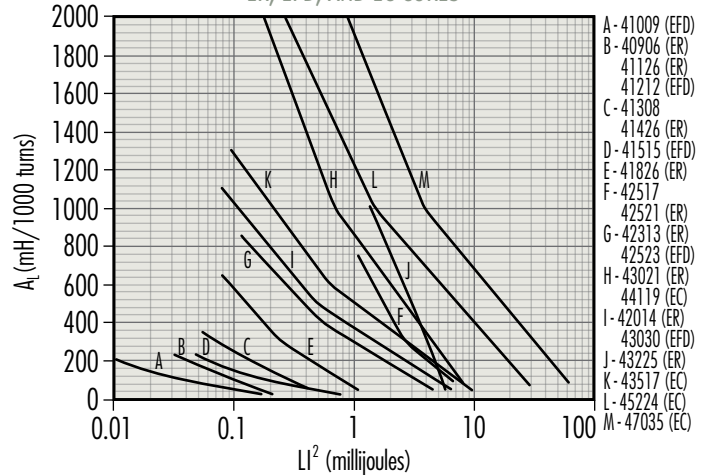

Inductor Design

DC BIAS DATA — FOR GAPPED APPLICATIONS

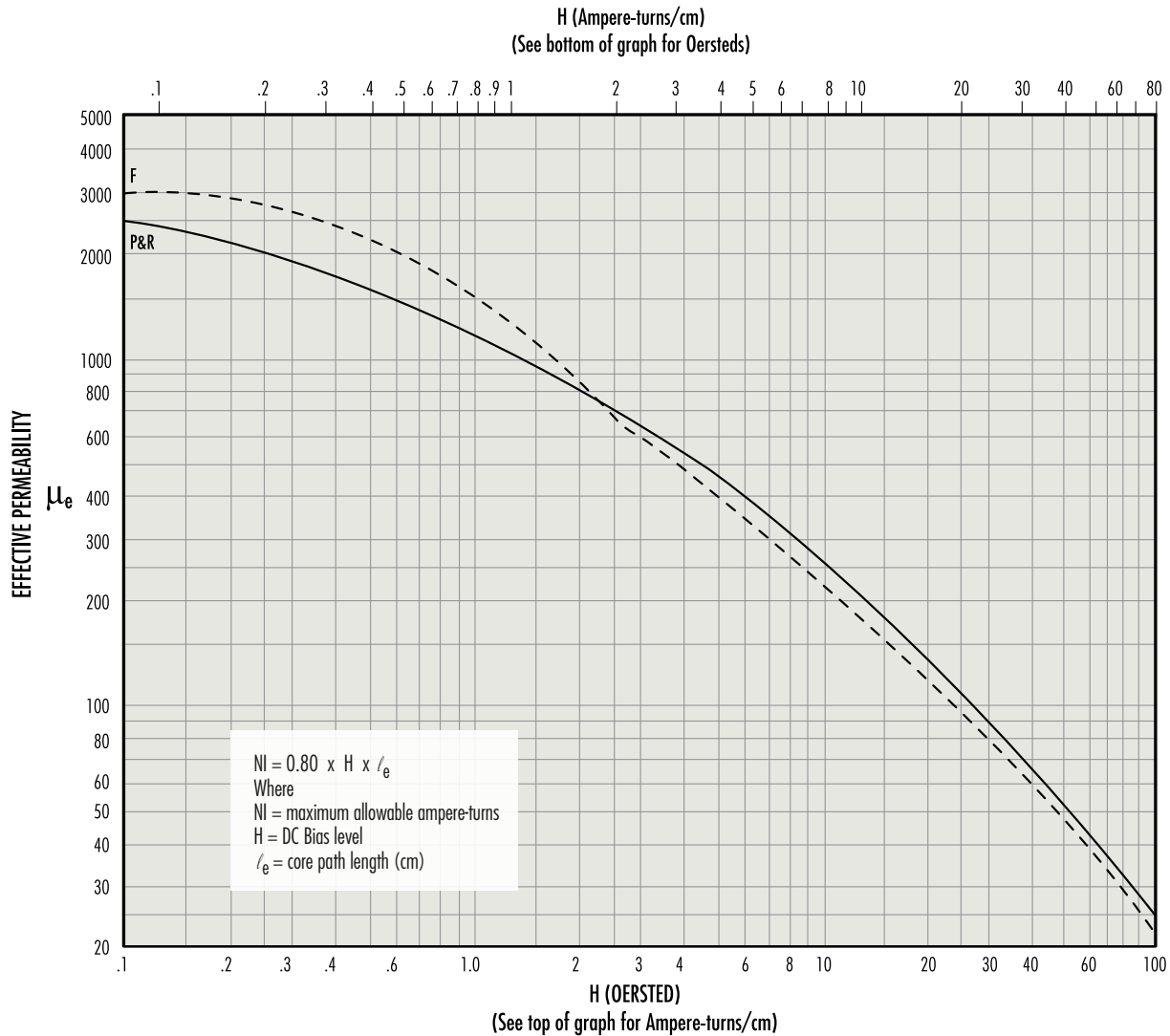

The above curves are limit curves, up to which *effective permeability* remains constant. They show the maximum allowable DC bias, in ampere-turns, without a reduction in inductance. Beyond this level (see insert), inductance drops rapidly.

Example: How many ampere-turns can be supported by an R42213A315 pot core without a reduction in inductance value?

$$l_e = 3.12 \text{ cm} \quad \mu_e = 125$$

Maximum allowable $H = 25$ Oersted (from the graph above)

NI (maximum) = $0.80 \times H \times l_e = 62.4$ ampere-turns
 or (Using top scale, maximum allowable $H = 20$ A·T/cm.)

$$\begin{aligned}
 NI \text{ (maximum)} &= A \cdot T / \text{cm} \times l_e \\
 &= 20 \times 3.12 \\
 &= 62.4 \text{ A} \cdot T
 \end{aligned}$$

$$\begin{aligned}
 \mu_e &= \frac{A_L \cdot l_e}{4 \pi A_e} \\
 \frac{1}{\mu_e} &= \frac{1}{\mu_i} + \frac{l_g}{l_e} \\
 A_e &= \text{effective cross sectional area (cm}^2\text{)} \\
 A_L &= \text{inductance/1,000 turns (mH)} \\
 \mu_i &= \text{initial permeability} \\
 l_g &= \text{gap length (cm)}
 \end{aligned}$$

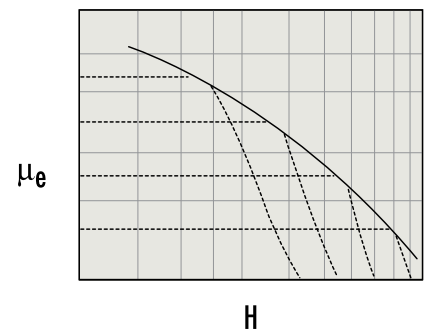

Inductance falls off rapidly above the limit curve. The dashed lines illustrate the μ_e curve for individual gapped core sets.

Transformer Design

Magnetics offers two methods to select a ferrite core for a power application.

CORE SELECTION BY POWER HANDLING CAPACITY

The Power Chart characterizes the power handling capacity of each ferrite core based upon the frequency of operation, the circuit topology, the flux level selected, and the amount of power required by the circuit. If these four specifics are known, the core can be selected from the Power Chart on page 68.

CORE SELECTION BY WaAc PRODUCT

The power handling capacity of a transformer core can also be determined by its WaAc product, where Wa is the available core window area, and Ac is the effective core cross-sectional area. Using the equation shown below, calculate the WaAc product and then use the Area Product Distribution (WaAc) Chart to select the appropriate core.

$$WaAc = \frac{P_o D_{cma}}{K_t B_{max} f}$$

WaAc = Product of window area and core area (cm⁴)

P_o = Power Out (watts)

D_{cma} = Current Density (cir. mils/amp) Current density can be selected depending upon the amount of heat rise allowed. 750 cir. mils/amp is conservative; 500 cir. mils is aggressive.

B_{max} = Flux Density (gauss) selected based upon frequency of operation. Above 20 kHz, core losses increase. To operate ferrite cores at higher frequencies, it is necessary to operate the core flux levels lower than ± 2 kG. The Flux Density vs. Frequency chart shows the reduction in flux levels required to maintain 100 mW/cm³ core losses at various frequencies, with a maximum temperature rise of 25°C for a typical power material, Magnetics P material.

A_c = Core area in cm²

V = Voltage

f = frequency (hertz)

I_p = Primary current

K_t = Topology constant

I_s = Secondary current

(for a space factor of 0.4)

N_p = Number of turns on the primary

N_s = Number of turns on the secondary

TOPOLOGY CONSTANTS K_t

Forward converter = 0.0005

Push-Pull = 0.001

Half-bridge = 0.0014

Full-bridge = 0.0014

Flyback = 0.00033 (single winding)

Flyback = 0.00025 (multiple winding)

For individual cores, WaAc is listed in this catalog under "Magnetic Data."

The WaAc formula was obtained from derivations in Chapter 7 of A. I. Pressman's book, "Switching Power Supply Design. Choice of B_{max} at various frequencies, D_{cma} and alternative transformer temperature rise calculations are also discussed in Chapter 7 of the Pressman book.

FLUX DENSITY VS. FREQUENCY P MATERIAL

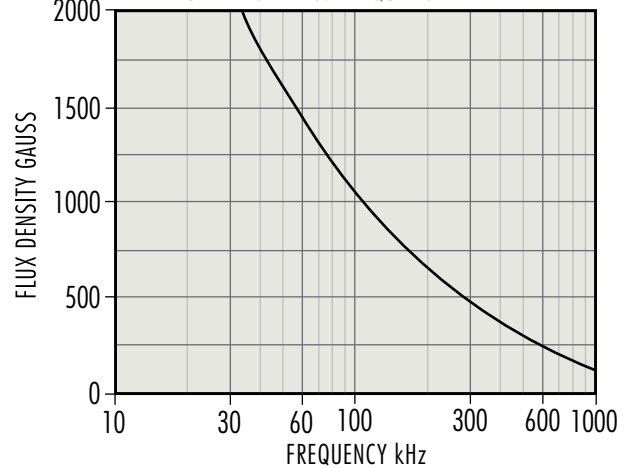

Once a core is chosen, the calculation of primary and secondary turns and wire size is readily accomplished.

$$N_p = \frac{V_p \times 10^8}{4BA_c f} \quad N_s = \frac{V_s}{V_p} N_p$$

$$I_p = \frac{P_{in}}{V_{in}} \quad I_s = \frac{P_{out}}{V_{out}}$$

$$KWA = N_p A_{wp} + N_s A_{ws}$$

Where

A_{wp} = primary wire area

A_{ws} = secondary wire area

Assume K = .4 for toroids; .6 for pot cores and E-I cores

Assume N_pA_{wp} = 1.1 N_sA_{ws} to allow for losses and feedback winding

$$\text{efficiency } e = \frac{P_{out}}{P_{in}} = \frac{P_{out}}{P_{out} + \text{wire losses} + \text{core losses}}$$

$$\text{Voltage Regulation (\%)} = \frac{V_{no\ load} - V_{full\ load}}{V_{full\ load}} \times 100$$

Typical Power Handling Chart

| Power in Watts | | | | Pot, RS, DS | E Cores | RM, PQ, EP | UU, UI, UR | ETD, EER, EC | EFD, Planar | Toroid |
|----------------|--------|---------|---------|----------------------------|----------------------|--|----------------------|-------------------------------------|---|--|
| 20 kHz | 50 kHz | 100 kHz | 250 kHz | | | | | | | |
| 2 | 3 | 4 | 7 | 41811 RS DS PC | 41205 EE 41707 EE | 41313 EP 41812 RM 41912 RM | | | 42107 EE 41805 EE | 40907 TC 41406 TC 41303 TC 41435 TC 41304 TC 41206 TC 41506 TC 41407 TC 41405 TC 41305 TC |
| 5 | 8 | 11 | 21 | 41814 PC 42311 RS DS HS | 41808 EE | 41717 EP 42013 RM 42016 PQ 42610 PQ | | | 42019 EFD 42216 EI 42214 EI 43208 EI | 41306 TC 41607 TC 41450 TC 41410 TC 41605 TC 41610 TC 41606 TC |
| 12 | 18 | 27 | 52 | | 41810 EE 42510 EE | 42316 RM | | | | |
| 13 | 20 | 29 | 56 | 42213 PC | | 42614 PQ | | | | |
| 15 | 22 | 32 | 62 | 42318 RS DS HS | | | | | 42214 EE | |
| 18 | 28 | 40 | 78 | | | 42020 PQ | | | 42523 EFD | |
| 19 | 30 | 42 | 83 | 42616 RS DS HS | 42513 EE 42515 EI | 42120 EP 43214 PQ | 42515 UI | | 42216 EE 43618 EI 42217 EE 44008 EI | 42106 TC 41809 TC |
| 26 | 42 | 58 | 113 | | | | | | 43208 EE | 42206 TC |
| 28 | 45 | 63 | 122 | | 42520 EE | | | | 43030 EFD | |
| 30 | 49 | 67 | 131 | 42616 RS PC | | 42620 PQ | | | | 42109 TC |
| 33 | 53 | 74 | 144 | | 42515 EE | 42819 RM | | | | 42207 TC |
| 40 | 61 | 90 | 175 | | 42526 EE 43007 EE | | | | | 42506 TC |
| 42 | 70 | 94 | 183 | 43019 HS | | 42625 PQ | | | 43618 EE | |
| 48 | 75 | 108 | 210 | 42823 PC 43019 RS DS PC | 43009 EE | | 42512 UU 42515 UU | 42929 ETD | 44008 EE | 42507 TC |
| 60 | 97 | 135 | 262 | | 42530 EE 43515 EE | 43220 PQ | | 43517 EC | 43808 EI | 42212 TC |
| 70 | 110 | 157 | 306 | 43622 DS HS | | 43723 RM | 42220 UU 42530 UU | 42814 EER 42817 EER 43434 ETD | | 42508 TC 42908 TC 42712 TC |
| 105 | 160 | 235 | 460 | 43622 RS | 44011 EE 44317 EE | | | | 44308 EI 44310 EI | |
| 120 | 195 | 270 | 525 | 43622 PC | | 43230 PQ | | | 43808 EE | 43806 TC |
| 130 | 205 | 290 | 570 | | 43520 EE | 44230 RM | | 44119 EC | 43809 EE | |
| 150 | 240 | 337 | 656 | | 44016 EE 44020 EI | | | 43521 EER 43939 ETD | 44308 EE | 43113 TC 42915 TC |
| 200 | 310 | 450 | 875 | | | | | | 44310 EE | 43610 TC |

Typical Power Handling Chart

| Power in Watts | | | | Pot, RS, DS | E Cores | RM, PQ, EP | UU, UI, UR | ETD, EER, EC | EFD, Planar | Toroid |
|----------------|--------|---------|---------|----------------|----------------------------------|---------------|--|------------------------------------|-------------|---|
| 20 kHz | 50 kHz | 100 kHz | 250 kHz | | | | | | | |
| 220 | 350 | 495 | 962 | | 44721 EE | | 44119 UR | | | |
| 230 | 350 | 550 | 1073 | 44229 RS DS | | 43535 PQ | 44121 UR | 44013 EER | | |
| 260 | 400 | 585 | 1137 | | | | | | | 43813 TC |
| 280 | 430 | 630 | 1225 | 44229 PC | 44020 EE | | | 44216 EER | | |
| 300 | 450 | 675 | 1312 | | | | | 44444 ETD 44818 EER 45224 EC | 45810 EI | 43615TC |
| 340 | 550 | 765 | 1487 | | 44033 EE | | 44125 UR | | | |
| 360 | 580 | 810 | 1575 | | 44022 EE | 44040 PQ | | 45418 EER | | 43620 TC |
| 410 | 650 | 922 | 1793 | | 44033 EE 45724 EE | | 44130 UR | 44821 EER 44949 ETD | 46410 EI | 44416 TC 44419 TC 43825 TC |
| 550 | 800 | 1237 | 2406 | | 46016 EE | | | | | 44015 TC 44715 TC |
| 650 | 1000 | 1462 | 2843 | | | 45050 PQ | | | 45810 EE | |
| 700 | 1100 | 1575 | 3062 | | 45528 EE | | 45716 UR | 45454 ETD | 46410 EE | 44920 TC 44916 TC |
| 900 | 1500 | 2000 | 3900 | | 45530 EE | | | | | 44925 TC |
| 1000 | 1600 | 2250 | 4375 | 43428 UG | 47228 EE 46022 EE | | 45917 UR | 45959 ETD 47035 EC | | 46013 TC 46113 TC |
| 1600 | 2600 | 3700 | 7215 | | | | 46420 UR | | | 44932 TC 46019 TC |
| 2000 | 3000 | 4500 | 8750 | | 46527 EE 47133 EE 48020 EE | | | | | 46325 TC 46326 TC 47313 TC |
| 2800 | 4200 | 6500 | 12675 | | | | 49316 UI 49316 UU | | 49938 EE | 48613 TC 48626 TC 47325 TC 49715 TC 48619 TC 49718 TC 48625 TC |
| 11700 | 19000 | 26500 | 51500 | | 49928 EE | | 49330 UU 49332 UU 49920 UU 49925 UI 49925 UU | | | 49725 TC 49740 TC |

Ferrite Core selection listed by typical Power Handling Capabilities (Chart is for Power Ferrite Materials, F, P, R, L and T, Push-Pull Square wave operation)

Wattage values shown above are for push-pull converter design. De-rate by a factor of 3 or 4 for flyback. De-rate by a factor of 2 for feed-forward converter.
Example: For a feed-forward converter to be used at 300 watts select a core that is rated at 600 watts based on the converter topology.

Note: Assuming core loss to be approximately 100 mW/cm³, B Levels used in this chart are:

@ 20 kHz - 200 mT, 2000 gauss; @ 50 kHz - 130 mT, 1300 gauss; @ 100 kHz - 90 mT, 900 gauss; @ 250 kHz - 70 mT, 700 gauss

Area Product Distribution (WaAc) Chart

| WaAc (cm ⁴) | RS, DS, HS | E | EC, EER, EFD, ETD | EP, RM | ER | Planar | Pot | PQ | TC | U, UR |
|-------------------------|----------------|----------------------|------------------------|----------------------------------|----------------------|----------------------------------|----------|----------------------------------|--|----------------------|
| <0.001 | | | | | | | | | 40200 TC 40301 TC 40502 TC | |
| 0.001 | | | | | | | | | 40401 TC 40402 TC 40503 TC 40601 TC | |
| 0.002 | | 40904 EE | | | | | 40704 UG | | | |
| 0.003 | | | | | 40906 EE | | 40905 UG | | 40603 TC | |
| 0.004 | | | 41009 EFD | | 41126 EE | | | | | |
| 0.005 | | | | 40707 EP | | | | | | |
| 0.006 | | | | | 41308 EI | | 41107 UG | | | |
| 0.008 | | | | | | 41434 EI | | | 40705 TC | |
| 0.01 | | | 41212 EFD | 41010 EP 41110 RM | 41308 EE 41426 EE | 41425 EE | 41109 UG | | 41003 TC | 41106 UI |
| 0.02 | 41408 RS DS HS | 41203 EE | 41515 EFD | 41510 RM | | 41434 EE | 41408 UG | | 41005 TC | 41106 UU |
| 0.03 | | 41205 EE 41707 EE | | 41313 EP | 41826 EE | 42107 EI 41805 EI | | | 40907 TC | |
| 0.04 | | | | | | 41805 EI | | | 41303 TC 41435 TC | |
| 0.05 | 41811 HS | | | 41812 RM | 42313 EE | | | | 41206 TC 41304 TC 41405 TC 41407 TC 41506 TC | |
| 0.06 | | | | 41717 EP 41912 RM | | 42107 EE | 41410 UG | | 41305 TC | |
| 0.07 | 41811 RS DS | | | | 42014 EI | 42107 EE 41805 EE | 41811 UG | 42610 UG | 41306 TC 41406 TC | |
| 0.08 | 42311 DS HS | 41808EE | | | 42517EI | | | | 41450TC | |
| 0.09 | | | 42019 EFD | | | | 41814 UG | | | |
| 0.1 | 42311 RS | 41810 EE | | | 42014 EE | 42216 EI | | | 41605 TC | |
| 0.2 | 42318 RS DS HS | 42510 EE 42515 EI | 42523 EFD | 42013 RM 42120 EP 42316 RM | 42517 EE 43021 EI | 42214 EI | 42213 UG | 42016 UG 42020 UG 42614 UG | 41606 TC 41607 TC 41410 TC 41610 TC | |
| 0.3 | 42616 RS DS HS | 42513 EE | 43030 EFD | | 42521 EE 43225 EE | 43618 EI 42216 EE 42214 EE | | 43214 UG | 41809 TC 42106 TC | 42515 UI |
| 0.4 | | 42526 EE | | 42819 RM | | 42217 EE 43208 EI 44008 EI | 42616 UG | 42620 UG | 42109 TC 42206 TC | |
| 0.5 | | 42520 EE 43007 EE | 42814 EER | | 43021 EE | | | | 42207 TC | |
| 0.6 | 43019 DS HS | 42515 EE 43009 EE | | | | 43618 EE | 42823 UG | 42625 UG | | 42220 UU 42515 UU |
| 0.7 | 43019 RS | 42530 EE | 42929 EFD 42817 EER | | | 43208 EE | 43019 UG | | 42507 TC | |
| 0.8 | | | 43517 EC | | | 44008 EE | | 43220 UG | 42506 TC 42212 TC | 42512 UU |
| 0.9 | | | | | | 43808 EI | | | 42508 TC | |

Area Product Distribution (WaAc) Chart

| WaAc (cm ²) | RS, DS, HS | E | EC, EER, EFD, ETD | EP, RM | ER | Planar | Pot | PQ | TC | U, UR |
|-------------------------|----------------|----------------------------------|---|----------|----|----------------------|----------|----------|----------------------------------|----------------------|
| <1 | 43622 RS DS HS | 43515 EE 44011 EE 44020 EI | 43434 ETD | 43723 RM | | 44308 EI | | | 42712 TC 42908 TC | 42530 UU |
| 2 | | 44016 EE 44317 EE 43520 EE | 43521 EER 43939 ETD 44013 EER 44119 EC | 44230 RM | | 44310 EI 43808 EE | 43622 UG | 43230 UG | 42915 TC 43113 TC 43806 TC | |
| 3 | 44229 RS DS | 44721 EE | 44216 EER 44818 EER | | | 43809 EE 44308 EE | | 43535 UG | 43610 TC 43813 TC | 44119 UR 44121 UR |
| 4 | | 44020 EE 44022 EE | 44444 ETD 44821 EER 45224 EC 45418 EER | | | 44310 EE | 44229 UG | | 43615 TC | 44125 UR |
| 5 | | | | | | 45810 EI | | 44040 UG | 43620 TC 44416 TC | 44130 UR |
| 6 | | 44033 EE 46016 EE | 44949 ETD | | | 46410 EI | | | 44419 TC | |
| 7 | | 45724 EE | | | | | | | 43825 TC 44015 TC | |
| 8 | | | | | | 45810 EE | | 45050 UG | 44715 TC | |
| 9 | | | 45454 ETD | | | | | | 44920 TC | 45716 UR |
| 10 | | 45528 EE | | | | | | | | |
| 11 | | | | | | 46410 EE | | | 44916 TC | |
| 12 | | 45530 EE | | | | | | | | |
| 13 | | | 47035 EC | | | | | | 44925 TC | |
| 14 | | | 45959 ETD | | | | | | | 45917 UR |
| 15 | | 47228 EE | | | | | | | | |
| 16 | | | | | | | | | 46013 TC 46113 TC | |
| 21 | | 46022 EE | | | | | | | 44932 TC | |
| 22 | | | | | | | | | | 46420 UU |
| 23 | | 47133 EE | | | | | 43428 UG | | | |
| 24 | | 46527 EE | | | | | | | | |
| 25 | | | | | | | | | 46019 TC 47313 TC | |
| 34 | | 48020 EE | | | | | | | 46325 TC 46326 TC | |
| 46 | | | | | | | | | 48613 TC | 49316 UI |
| 51 | | | | | | 49938 EE | | | 47325 TC | |
| 61 | | | | | | | | | | 49925 UI |
| 70 | | | | | | | | | 48619 TC | |
| 91 | | 49928 EE | | | | | | | 48625 TC 48626 TC 49715 TC | 49316 UU |
| 106 | | | | | | | | | 49718 TC | |
| 121 | | | | | | | | | | 49925 UU |
| 171 | | | | | | | | | 49725 TC | |
| 286 | | | | | | | | | | 49920 UU |
| 372 | | | | | | | | | 49740 TC | |

Other Products from Magnetics



POWDER CORES

Powder cores are excellent as low loss inductors for switched-mode power supplies, switching regulators and noise filters. Most core types can be shipped immediately from stock.

Magnetics **Kool M μ** [®] powder cores exhibit low losses at elevated frequencies. Kool M μ is available in 7 permeabilities and a variety of core types for maximum flexibility. Toroids offer compact size and self-shielding. E cores, U cores, EQ cores, and LP cores afford lower cost of winding, use of foil windings or helical windings, and ease of fixturing. For very high current applications, very large cores and structures are available including toroids up to 165 mm, large E cores, U cores, stacked shapes, and blocks.

Magnetics **Kool M μ** [®] **MAX** powder cores offer 50% better DC bias performance than standard Kool M μ material. Available in 7 permeabilities from 14 μ to 90 μ including toroids, blocks, U cores and E cores.

Magnetics **Kool M μ** [®] **Hf** powder cores are the best option for achieving superior efficiency in medium and high current power inductors and are available in 26 μ , 40 μ and 60 μ .

Magnetics **XFlux**[®] powder cores are made from 6.5% silicon iron powder for very high saturation flux density, comparable with High Flux. XFlux is available in 7 permeabilities from 19 μ to 125 μ and multiple shapes including toroids, E cores, block cores, EQ cores, LP cores, and EER cores.

Magnetics **High Flux** powder cores exhibit very high resistance to saturation at high current. High Flux is available in 7 permeabilities from 14 μ to 160 μ and over 30 sizes. Shapes include toroids, EQ cores, LP cores, and EER cores.

Magnetics **Edge**[®] powder cores are the best option for achieving smallest package size in high frequency, current-limited power inductors and are available in 5 permeabilities from 19 μ to 125 μ .

Magnetics **Molypermalloy (MPP)** powder cores have extremely low core losses, highest Q, and best temperature stability compared with other materials. Standard cores include either temperature stabilized (guaranteed flat as wide as -65°C to 125°C for stable operation) or standard stabilization. MPP toroidal cores are available in 10 permeabilities from 14 μ to 550 μ and sizes identical to High Flux.



TAPE WOUND CORES

Strip wound cores are made from high permeability magnetic strip alloys of nickel-iron (80% or 50% nickel), and silicon-iron. The alloys are known as Orthonal[®], Permalloy 80, 48 Alloy and Magnesil[®]. Tape Wound Cores are produced as small as 0.438" OD in hundreds of sizes. For a wide range of frequency applications, materials are produced in thicknesses from 1/2 mil (0.013 mm) through 4 mils (0.102 mm). Cases are robust nylon and aluminum boxes, rated for 200°C continuous operation and 2,000 minimum voltage breakdown.

Tape wound cores are useful for both power and signal circuits in harsh environmental conditions where robust component operation is essential to achieve high reliability.

BOBBIN CORES

Bobbin cores are miniature tape cores made from ultrathin (0.000125" to 0.001" thick) strip material wound on nonmagnetic stainless steel bobbins. Bobbin cores are generally manufactured from Permalloy 80 and Orthonal[®]. Covered with protective caps and then epoxy coated, bobbin cores can be made as small as 0.05" ID and with strip widths down to 0.032". Bobbin cores can switch from positive to negative saturation in a few microseconds or less, with very high peak impedance (relative permeability) while not saturated, making them ideal for analog logic elements, magnetometers, and pulse transformers.

Bobbin cores are also useful for analog counters, timers, magnetic sensors, and other analog circuits in harsh environmental conditions where robust and reliable operation is essential.

NANOCRYSTALLINE CORES

Nanocrystalline cores are made from amorphous metal which is annealed to create a uniform nanocrystalline microstructure. Sizes include toroids and split cores from 5 mm to 145 mm, and durable cases are available in polyester (<130°C) and rynite polyester (<155°C). Nanocrystalline cores are a choice solution for applications such as common mode chokes and current transformers as they exhibit high permeability, low power loss, and high saturation.

AMORPHOUS CORES

Amorphous cores are made from metallic glass materials with an amorphous atomic structure, which creates higher resistivity than nanocrystalline cores. Amorphous cores offer excellent frequency response and efficiency, and they are a choice solution for high frequency, low loss applications. Magnetics offers amorphous cut cores (C shape) from 51 mm to 131 mm, with toroids and split cores available upon request.

Website

For updates and more in-depth product information, visit mag-inc.com

- Design Equations
- Area Product Distribution (WaAc) and Power Charts
- Product Datasheets
- Product Catalogs
- Design Software
- Distributor Stock Check
- Part Number Search
- Cross Reference Tool





Headquarters

110 Delta Drive
P.O. Box 11422
Pittsburgh, PA 15238 • USA

Phone: **1.800.245.3984**
+1.412.696.1333

e-mail: magnetics@spang.com

Magnetics International

13/F 1-3 Chatham Road South
Tsim Sha Tsui
Kowloon, Hong Kong

Phone: **+852.2731.9700**
+86.139.1147.1417

e-mail: asiasales@spang.com

www.mag-inc.com

©2022 Magnetics

