

cannon

MKJ4 Series Connectors  
Miniature Circular Catalog



**ITT**

ENGINEERED FOR LIFE

# Amazing things happen when great things connect

ITT Cannon is a leading global manufacturer of connector products serving international customers in the aerospace and defense, medical, energy, transportation and industrial end markets. Whether delivering critical specs to aircraft pilots, streaming data through communications satellites or enabling ultrasound technology that gives an expectant mother the first glimpse of her unborn child, Cannon connects the world's most important information with the people who need it.

No one is more qualified to help you equip military personnel than ITT Cannon. With 100 years of interconnect excellence and a global presence in the Aerospace & Defense Industry, we are a committed partner among today's commercial and military equipment manufacturers. We continue to lead the market and meet the military's needs for adaptability, mobility and survivability. And we do so with one goal in mind: to get our soldiers back home safely.



## A Century of Connections

In 2015, Cannon marked its 100th Anniversary of Innovation. Cannon products were used in the first "talking" movies and helped transmit the first messages back to earth when we landed on the moon. Today we proudly continue our legacy of innovating to connect the world and inspire the successes of the next century – because amazing things happen when great things connect.

Visit [ittcannon.com](http://ittcannon.com) to learn more.

## About ITT

ITT is a diversified leading manufacturer of highly engineered critical components and customized technology solutions for the energy, transportation and industrial markets. Building on its heritage of innovation, ITT partners with its customers to deliver enduring solutions to the key industries that underpin our modern way of life. This work is made possible by the talent and innovation of committed ITT employees in more than 35 countries who create trusted products and brands such as Goulds Pumps, KONI shock absorbers, Cannon connectors and Enidine energy absorption devices. Founded in 1920, ITT is headquartered in White Plains, N.Y. For more information, visit [itt.com](http://itt.com)

Our connector portfolio remains one of the most extensive in the industry, providing customers with a reliable and cost-effective range of interconnect solutions.

Visit [ittcannon.com](http://ittcannon.com) to learn more.



Medical Equipment



Marine Vessels



Rail



Soldier-Worn Systems

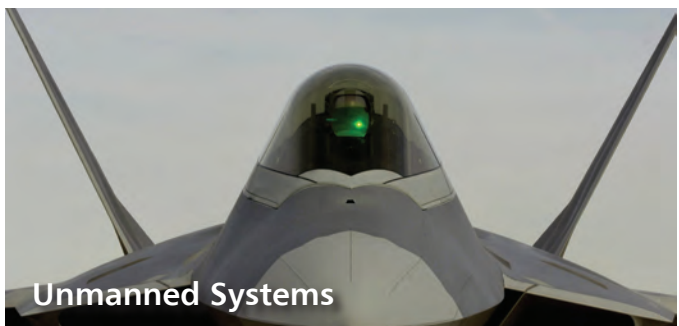

Unmanned Systems



Heavy Equipment



Commercial Aircraft



Oil & Gas

# Table of Contents

**MKJ Miniature Circular Connectors . . . . . 5**

**We Connect Soldiers with Smaller, Lighter Wearable Technology . . . . . 6**

**Markets & Applications . . . . . 7**

**Coupling Styles . . . . . 8**

**Overview MKJ4 Breakaway . . . . . 9**

**MKJ4 Contact Arrangements & Layouts . . . . . 10-11**

**MKJ4 Plug (Banded & Accessory Thread) . . . . . 12-14**

**MKJ4 Plug Flange Mount Rear Panel, Jam Nut Rear Mount, Jam Nut Front Mount . . . . . 15-16**

**MKJ4 Plug Flange Mount Rear Panel (Potted, PCB & Solder Cup). . . . . 17**

**MKJ4 Plug Jam Nut Rear Mount (Potted, PCB & Solder Cup) . . . . . 18**

**MKJ Plug Jam Nut Front Mount (Potted, PCB & Solder Cup) . . . . . 19**

**MKJ4 Receptacle In-Line Receptacle, Jam Nut Rear Mount, Jam Nut Front Mount . . . . . 20-21**

**MKJ4 Receptacle In-Line (Banded & Accessory Thread) . . . . . 22**

**MKJ4 Receptacle Jam Nut Rear Mount (Banded & Accessory Thread) . . . . . 23**

**MKJ4 Receptacle Jam Nut Front Mount (Banded & Accessory Thread). . . . . 24**

**MKJ4 Receptacle Jam Nut Rear Mount, Jam Nut Front Mount (PCB & Solder Cup) . . . . . 25-26**

**MKJ4 Receptacle Jam Nut Rear Panel Mount (Potted, PCB & Solder Cup) . . . . . 27**

**MKJ4 Receptacle Jam Nut Front Panel Mount (Potted, PCB & Solder Cup). . . . . 28**

**MKJ4 Weight Charts . . . . . 29**

**MKJ Accessories . . . . . 30-31**

**Cables to Outfit MKJ Connectors. . . . . 32**

**About ITT Cannon . . . . . 33**

**Product Safety Information . . . . . 34**

**Meet Some of our Most Innovative Connectors . . . . . 35**

# MKJ Series Connectors

71% weight and 52% size reduction in an industry-leading quick disconnect\*

ITT Cannon continues its tradition of innovation with the MKJ line of miniature circular connectors. Bringing together a unique combination of design, functionality and flexibility, Cannon's MKJ Series offers proven, reliable and cost-effective interconnect solutions that enable critical communication, navigation and high speed data transmission—at half the size and weight of traditional ones. Choose from UNC thread, double start, triple start, bayonet and breakaway coupling methods in a cost-efficient, lightweight and highly engineered design.



**MKJ0**  
UNC Thread



**MKJ1**  
Double Start



**MKJ3**  
Bayonet



**MKJ4**  
Breakaway



**MKJ5**  
Triple Start



## Key Features

- 71% weight and 52% size reduction without the loss of reliability\*
- Available in rear-release crimp, PC tail or solder cup contacts
- Shells and jam nuts available in aluminum alloy or corrosion resistant stainless steel
- Up to 2,000 mating cycles
- Environmentally sealed using fluorosilicone material for the front interfacial seal and rear wire sealing grommet
- RoHS Compliant

\*When compared to the 38999 layouts with size 22 contacts

# We Connect Modern Soldiers with Smaller, Lighter Wearable Technology

From extended foot patrols to combat assignments and missions, today's soldiers and military personnel must be equipped with the most advanced, lightweight and cost-efficient equipment available. Made to the smallest form factor possible for required signals and performance, and available in a variety of coupling styles, Cannon's MKJ Miniature Circular Connectors are ready to take on your toughest challenges, even in the harshest environments.

## Today's Soldiers Carry an Average Load of 87-127 lbs. (39 - 57 kg)

On average, a modern soldier carries anywhere from 87 to 127 lbs. of equipment. This includes clothing, helmets, canteens, weapons, communications, computers, ammunition and body armor. At half the size and weight of D38999 connectors, Cannon's MKJ Miniature Circular Connectors can help lighten the load without sacrificing reliability or performance. That's because Cannon's MKJ Connectors provide similar electrical and mechanical characteristics as larger and heavier Military Standard Environmental interconnects, but in a significantly smaller design.\*



# Markets & Applications

Cannon MKJ Miniature Circular Connectors are designed for soldier-worn systems, military equipment, industrial and medical applications...and so much more.



## Key Applications

- Sensors
- Satellites
- Instrumentation
- Missile systems
- Avionic systems
- Soldier technology
- UAVs / unmanned systems
- Navigation & telemetry equipment
- Medical test & diagnostic equipment
- Ruggedized computers
- Hand-held communication equipment
- Commercial & military aircraft electronics
- Industrial equipment

## Highlights

- Versatile and proven for use in **military, industrial and medical applications** where safety and reliability are critical
- A number connectors in the MKJ Series offer a **2,000 mating cycle**, making them the perfect solution for ruggedized computers and hand-held communications equipment
- **Multiple coupling mechanisms** enable connectivity for navigation and telemetry applications
- Plugs and receptacles are **environmentally sealed** for use in the harshest environments
- **Teflon nickel, black zinc nickel and olive drab cadmium** plating maintain robust reliability for 500 hours of salt spray
- **RoHS Compliant** plating and part numbers available

# A Wide Range of Coupling Styles

The wide range of coupling options available for the MKJ Series allows compatible connectors to meet your demands even in the harshest environments.



Coupling	MKJ0 UNC Thread	MKJ1 Double Start	MKJ3 Bayonet	MKJ4 Breakaway	MKJ5 Triple Start
Markets & Segments	Defense, Aerospace, Medical, Industrial, Commercial				
Hardware	Aluminum/ Stainless Steel	Aluminum/ Stainless Steel	Aluminum/ Stainless Steel	Aluminum/ Stainless Steel	Aluminum/ Stainless Steel
EMI Shielding Effectiveness	40dB Attenuation, 100MHz to 1000MHz				
Mating Cycles	2000	2000	250 Aluminum 2000 Stainless Steel	2000	500
RoHS Compliant	Available				
Materials	Shells - Aluminum Alloy or Stainless Steel Insulators - Thermoplastic Seals - Fluorosilicone Contacts - Copper Alloy with gold over nickel plating				

## Product Performance

MKJ Series Performance				
Contact Size	#23	#20HD	#16	#12
Spacing	.076"	.106"	.170"	.230"
Contact Type	Rear Crimp, Solder Cup, PCB Mount			
Current Rating	5 Amps	7.5 Amps	13 Amps	23 Amps
Wire Accommodation	#22 - #28 AWG	#20 - #24 AWG	#16 - #20 AWG	#12 - #14 AWG
DWV Voltage (VAC)	750 VAC	1000 VAC	1800 VAC	1800 VAC
Insulation Resistance	5000 Megaohms RMS Sea			
Operating Temperature	-65°C to +175°C			
Contact Resistance	8 Millihoms Maximum			
Shock/Vibration	300g / 37g			
Clocking Position	Master Key and 2 Secondary Keys. 6 Clocking Positions			
Housing Materials	Aluminum and Stainless Steel			
Receptacle Mounting	Jam Nut, Square Flange, In-Line			

# Overview

## MKJ4 Breakaway

ITT Cannon's MKJ4 features a canted retention spring disconnect coupling mechanism. This durable coupling mechanism allows quick and easy mating and de-mating of the connector. Ideal for battlefield and medical device equipment.









MKJ4's versatility, performance and reliability enable unparalleled functionality to support critical communication, navigation and high speed data transmission needs, at half the size and weight of traditional connectors.\*

Specifications			
<b>Contact Type</b>	Rear Crimp, Solder Cup, PCB Mount	<b>Insulation Resistance</b>	5,000 Megaohms RMS Sea
<b>Contact Spacing</b>	Size 23 (0.076" spacing), Size 20HD (0.106" spacing), Size 16 (0.170" spacing), Size 12 (0.230" spacing)	<b>Operating Temperature</b>	-65°C to +175°C
		<b>Contact Resistance</b>	8 Milliohms Maximum
		<b>Shock/Vibration</b>	300g / 37g
<b>Wire Accommodation</b>	Size 23 #22 - #28 AWG, Size 20HD #20 - #24 AWG, Size 16 #16 - #20 AWG, Size 12 #12 - #14 AWG	<b>EMI Shielding Effectiveness</b>	40dB Attenuation, 100MHz to 1000MHz
		<b>Coupling</b>	Quick Disconnect (Canted Spring)
<b>Contact Rating</b>	Size 23 5 Amps, Size 20HD 7.5 Amps, Size 16 13 Amps, Size 12 23 Amps	<b>Receptacle Mounting</b>	Jam Nut, Flange, In-Line
		<b>Durability</b>	2,000 Mating Cycles
<b>DWV Voltage (VAC)</b>	Size 23 750 VAC, Size 20HD 1000 VAC, Size 16 1800 VAC, Size 12 1800 VAC	<b>Layouts</b>	See Available Layout on Pages 10-11
		<b>Materials</b>	Shells - Aluminum Alloy or Stainless Steel
			Insulators - Thermoplastic
			Seals - Fluorosilicone
		Contacts - Copper alloy with gold over nickel plating	
		Canted Spring - Stainless Steel	

\*When compared to the 38999 layouts with size 22 contacts

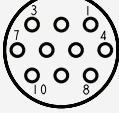
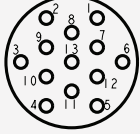
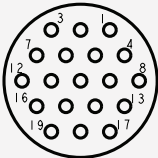
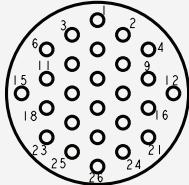
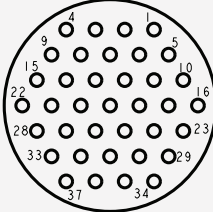
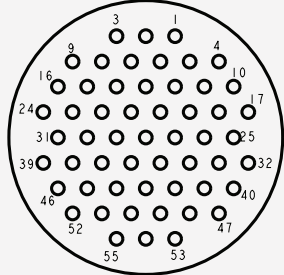
# MKJ4 Contact Arrangements & Layouts

Contact Arrangements							
Layout	Contacts						
	Size 23						
5-3	3						
6-4	4						
6-6	6						
6-7	7						
7-10	10						
8-13	13						
9-19	19						
10-26	26						
12-37	37						
14-55	55						

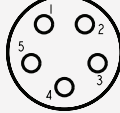
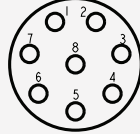
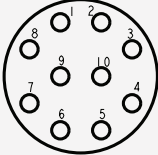
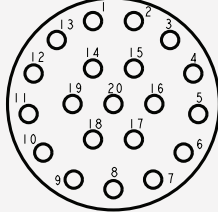
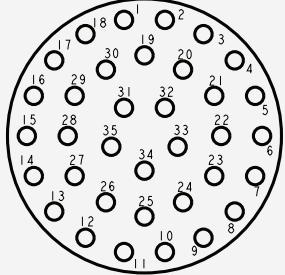
Contact Arrangements				
Layout	Contacts			
	Size 20HD			
6-23	3			
7-25	5			
8-28	8			
9-210	10			
12-220	20			
14-235	35			

Note: Pin insert front side shown for reference only. Socket insert is a mirror image.

# MKJ4 Contact Arrangements & Layouts

Contact Arrangements							
Layout	Contacts						
	Size 16						
6-1	1						
8-2	2						
9-4	4						
10-5	5						
12-7	7						
14-12	12						



6-1 Layout



8-2 Layout



9-4 Layout



10-5 Layout

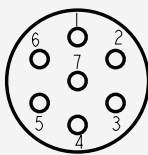

12-7 Layout

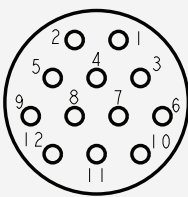

14-12 Layout

Contact Arrangements						
Layout	Contacts					
	Size 12					
7-1	1					
10-2	2					
12-2	2					
12-3	3					
14-5	5					



7-1 Layout



10-2 Layout

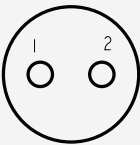

12-2 Layout

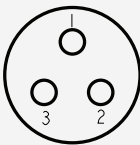

12-3 Layout

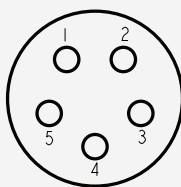

14-5 Layout

Note: Pin insert front side shown for reference only. Socket insert is a mirror image.

# MKJ4 Plug

## Banded & Accessory Thread

MKJ4 Plug (Shown with Banding/Overmolding Attachment)



MKJ4 Plug with Pin Insert (Banding Version)

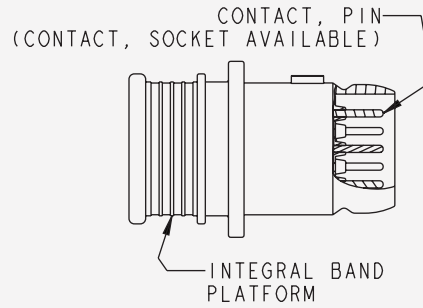

# How to Order – MKJ4 Plug

## Banded & Accessory Thread

Product	MKJ4 (Breakaway/Quick Disconnect)		MKJ4	A	6	F	9-19	P	A	**	
Class:	A -	Environmental Plug with Banding/Overmolding Attachment									
	B -	Environmental Plug with Threaded Accessory Attachment									
Shell Style:	6 -	Straight Plug									
Material/Plating:	C -	Aluminum/Anodize, Black									
	F -	Aluminum/Electroless Nickel									
	K -	Stainless Steel/Passivated									
	T -	Aluminum/Teflon Nickel									
	W -	Aluminum/Olive Drab Cadmium									
	Y -	Stainless Steel/Electroless Nickel, Black									
	Z -	Aluminum/Zinc Nickel, Black									
	N -	Stainless Steel/Electroless Nickel									
Shell Size/Contact Arrangement:		See Available Layouts on Pages 10–11									
Contact Style:	P -	Pin, Crimp, Removable									
	S -	Socket, Crimp, Removable									
	E -	Pin, Solder Cup, Potted, Non-removable									
	F -	Socket, Solder Cup, Potted, Non-removable									
Shell Clocking:	Omit	Single Keyway									
	A -	Normal									
	B, C, D, E, F	Alternatives									
Modification Codes:	- F0	Less Contacts ("F0" not stamped on the connector, but must be included on the P.O.)									
	- F256	Stainless Steel Hood (Socket contact only)									
	- 518	Potted connectors with water immersion testing (10 <sup>-4</sup> Helium leak tested)									

Consult factory for other modification codes

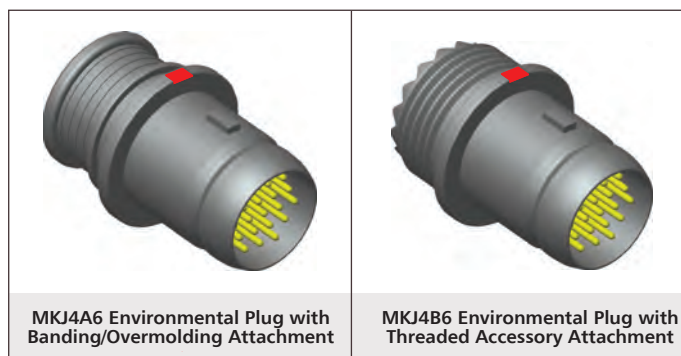

# MKJ4 Plug

## Banded & Accessory Thread

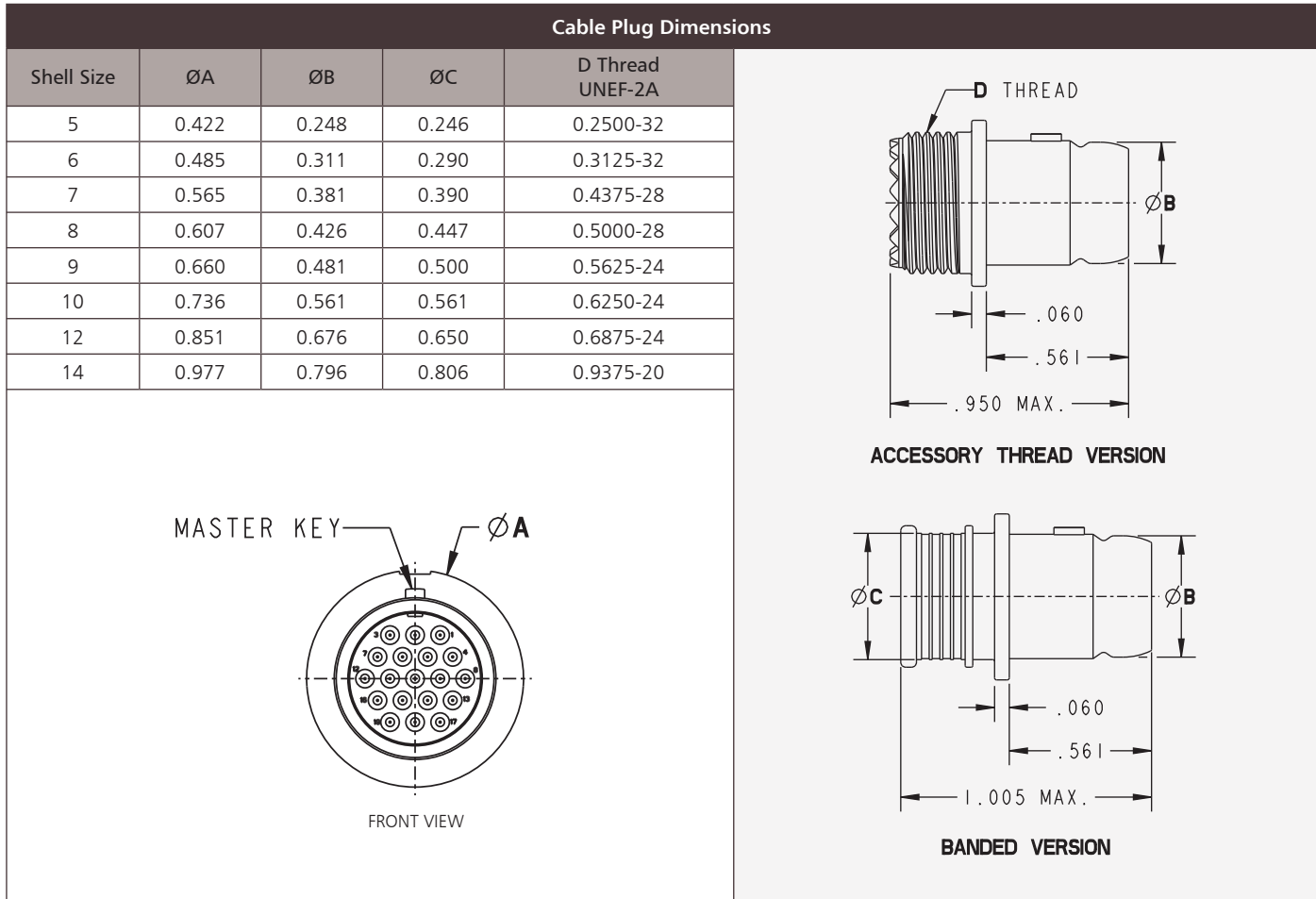

For all Shell Sizes and Clockings, the Master Keyway remains stationary at top dead center, with minor keys rotating to achieve alternate clocking positions.

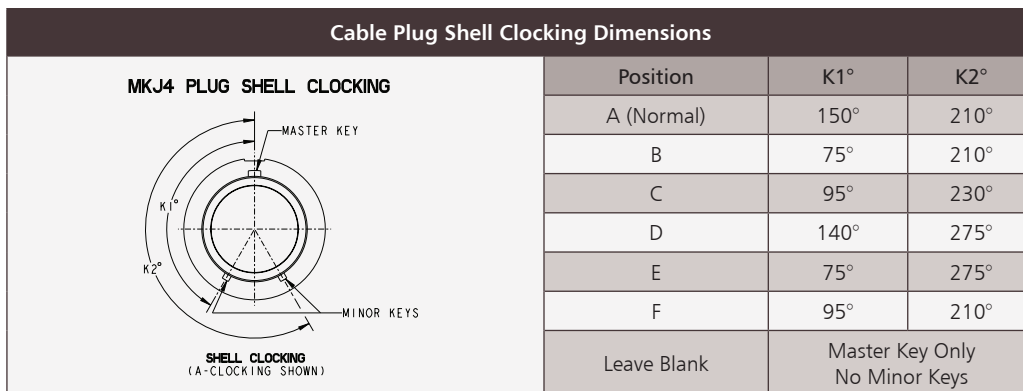

# MKJ4 Plug

Flange Mount Rear Panel, Jam Nut Rear Mount,  
Jam Nut Front Mount

## MKJ4 Plug (Flange Mount Rear Panel)



MKJ4 Plug Flange Mount Rear Panel  
with Pin Insert

CONTACT, PIN  
(CONTACT, SOCKET AVAILABLE)

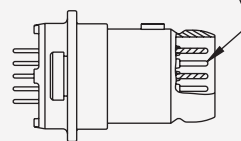

## MKJ4 Plug Jam Nut Rear Mount



MKJ4 Plug Jam Nut Rear Mount  
with Pin Insert

CONTACT, PIN  
(CONTACT, SOCKET AVAILABLE)

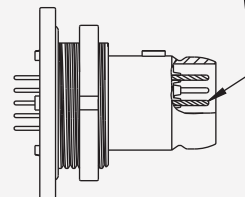

## MKJ4 Plug Jam Nut Front Mount

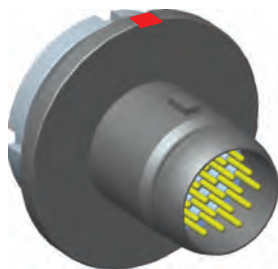

MKJ4 Plug Jam Nut Front Mount  
with Pin Insert

CONTACT, PIN  
(CONTACT, SOCKET AVAILABLE)

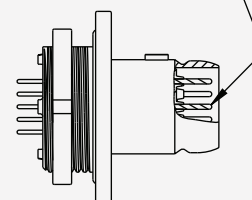

# How to Order – MKJ4 Plug

Flange Mount Rear Panel, Jam Nut Rear Mount, Jam Nut Front Mount

Product	MKJ4 (Breakaway/Quick Disconnect)								
	MKJ4	C	9	F	9-19	B	A	**	
Class:	C -	Potted Plug - PC/Flex/Solder							
Shell Style:	4 -	Flange Mount Rear Panel (Box Mount Plug)							
	9 -	Jam Nut Plug-Rear Panel Mount							
	10 -	Jam Nut Plug-Front Panel Mount							
Material/Plating:	C -	Aluminum/Anodize, Black							
	F -	Aluminum/Electroless Nickel							
	K -	Stainless Steel/Passivated							
	T -	Aluminum/Teflon Nickel							
	W -	Aluminum/Olive Drab Cadmium							
	Y -	Stainless Steel/Electroless Nickel, Black							
	Z -	Aluminum/Zinc Nickel, Black							
	N -	Stainless Steel/Electroless Nickel							
Shell Size/Contact Arrangement		See Available Layouts on Pages 10–11							
Contact Style:	B -	Pin, PC Tail, .109 Extension, Potted, Non-removable							
	D -	Socket, PC Tail, .109 Extension, Potted, Non-removable							
	E -	Pin, Solder Cup, Potted, Non-removable							
	F -	Socket, Solder Cup, Potted, Non-removable							
Shell Clocking:	Omit	Single Keyway							
	A -	Normal							
	B, C, D, E, F	Alternatives							
Modification Codes:	- F256	Stainless Steel Hood (Socket contact only)							
	- 518	Potted connectors with water immersion testing (10 <sup>-4</sup> Helium leak tested)							

Consult factory for other modification codes



# MKJ4 Plug

Flange Mount Rear Panel  
Potted, PCB & Solder Cup

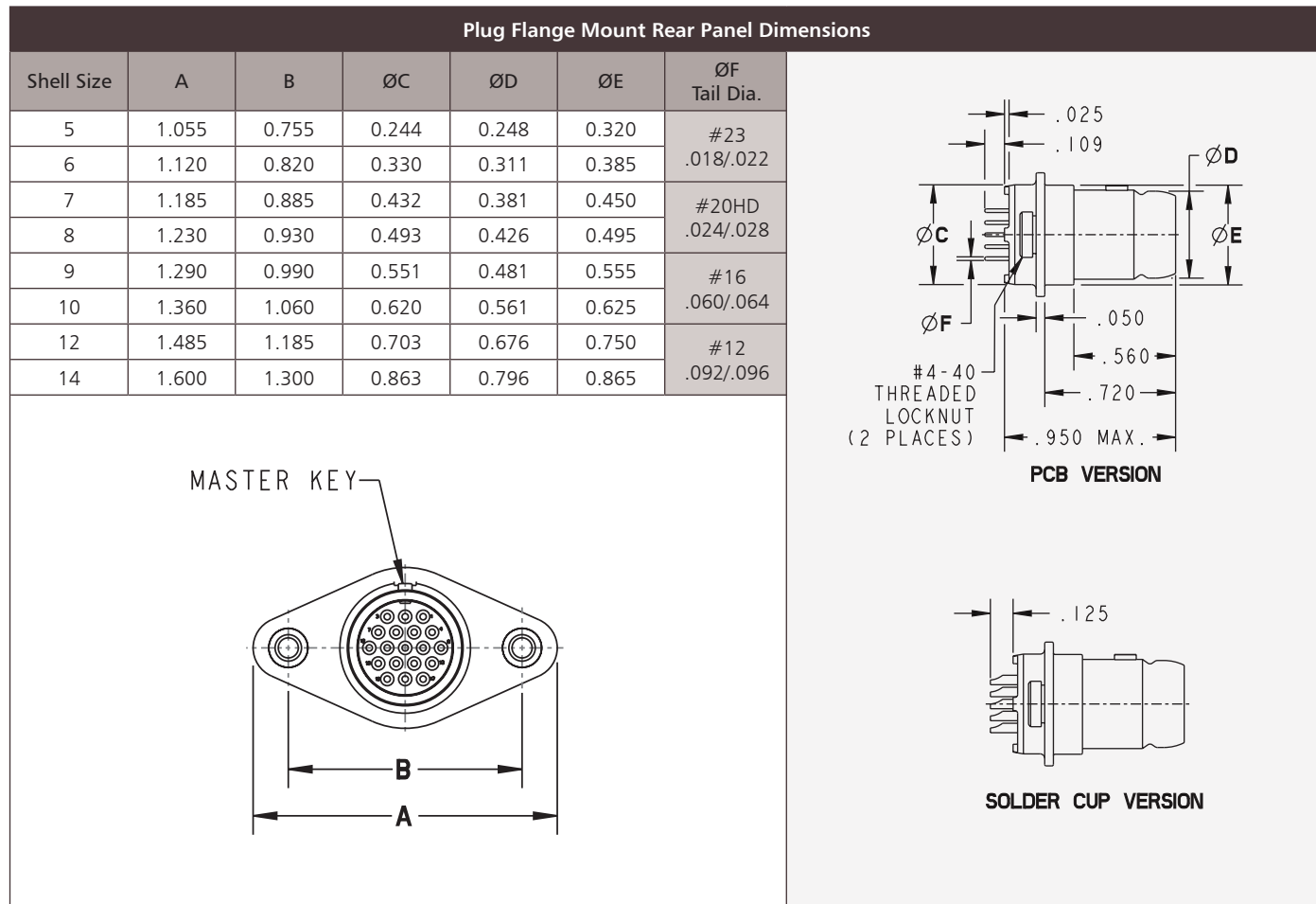

For all Shell Sizes and Clockings, the Master Keyway remains stationary at top dead center, with minor keys rotating to achieve alternate clocking positions.

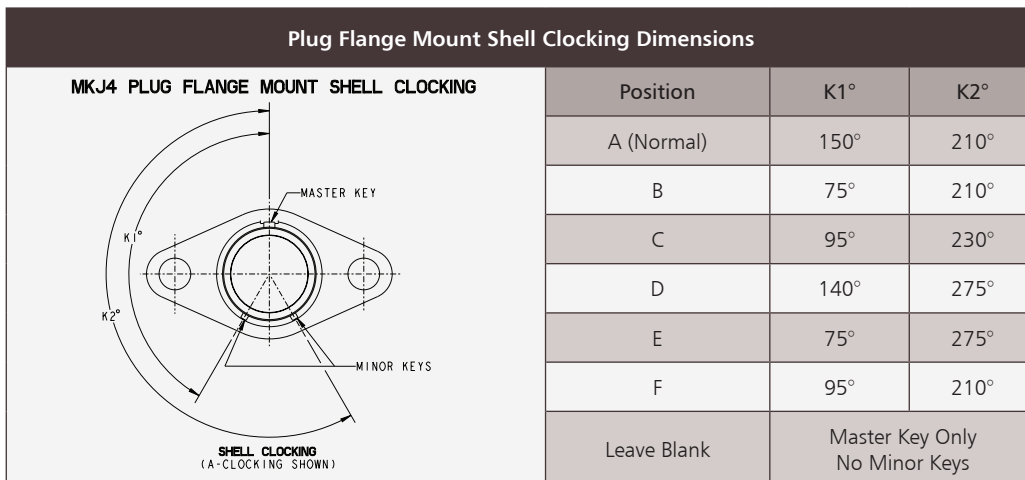

Dimensions shown in inches (mm)  
Specifications and dimensions subject to change

# MKJ4 Plug

Jam Nut Rear Mount  
Potted, PCB & Solder Cup

Plug Jam Nut Rear Mount Dimensions

Shell Size	ØA	ØB	C Flat	D Thread UN-2A	ØE	ØF Tail Dia.	G (Flat) + .002	ØH + .005
5	0.790	0.248	0.415	0.4375-28 UNEF	0.244	#23 .018/.022	0.423	0.448
6	0.830	0.311	0.467	0.5000-32	0.330		0.475	0.505
7	0.910	0.381	0.594	0.6250-28	0.432	#20HD .024/.028	0.602	0.635
8	0.955	0.426	0.594	0.6250-28	0.493		0.602	0.635
9	1.000	0.481	0.655	0.6875-28	0.551	#16 .060/.064	0.663	0.698
10	1.085	0.561	0.721	0.7500-28	0.620		0.726	0.76
12	1.180	0.676	0.843	0.8750-28	0.703	#12 .092/.096	0.851	0.885
14	1.325	0.796	0.968	1.0000-28	0.863		0.976	1.01

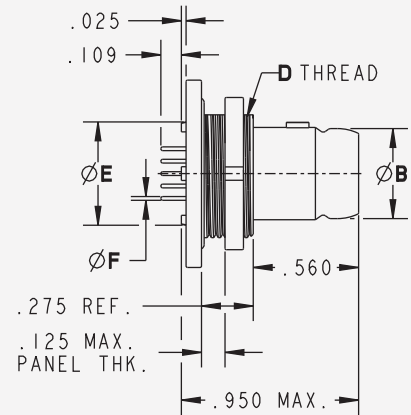

PCB VERSION

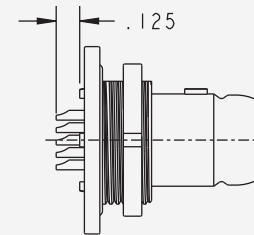

SOLDER CUP VERSION

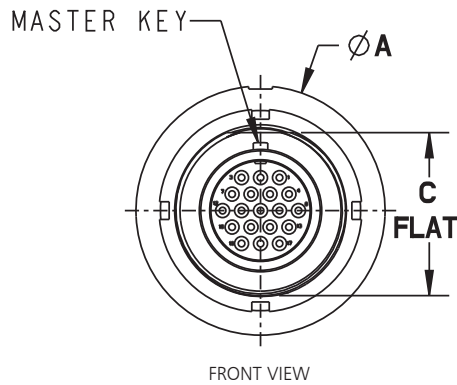

For all Shell Sizes and Clockings, the Master Keyway remains stationary at top dead center, with minor keys rotating to achieve alternate clocking positions.

Plug Jam Nut Rear Mount Shell Clocking Dimensions

MKJ4 PLUG JAM NUT REAR MOUNT SHELL CLOCKING	Position	K1°	K2°
	A (Normal)	150°	210°
B	75°	210°	
C	95°	230°	
D	140°	275°	
E	75°	275°	
F	95°	210°	
Leave Blank		Master Key Only	No Minor Keys

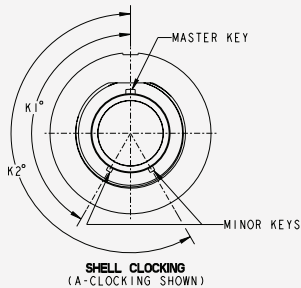

Panel Cutout Dimensions

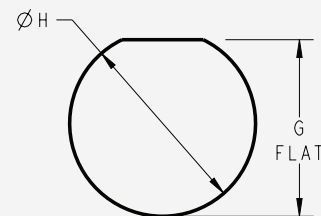

# MKJ4 Plug

## Jam Nut Front Mount Potted, PCB & Solder Cup

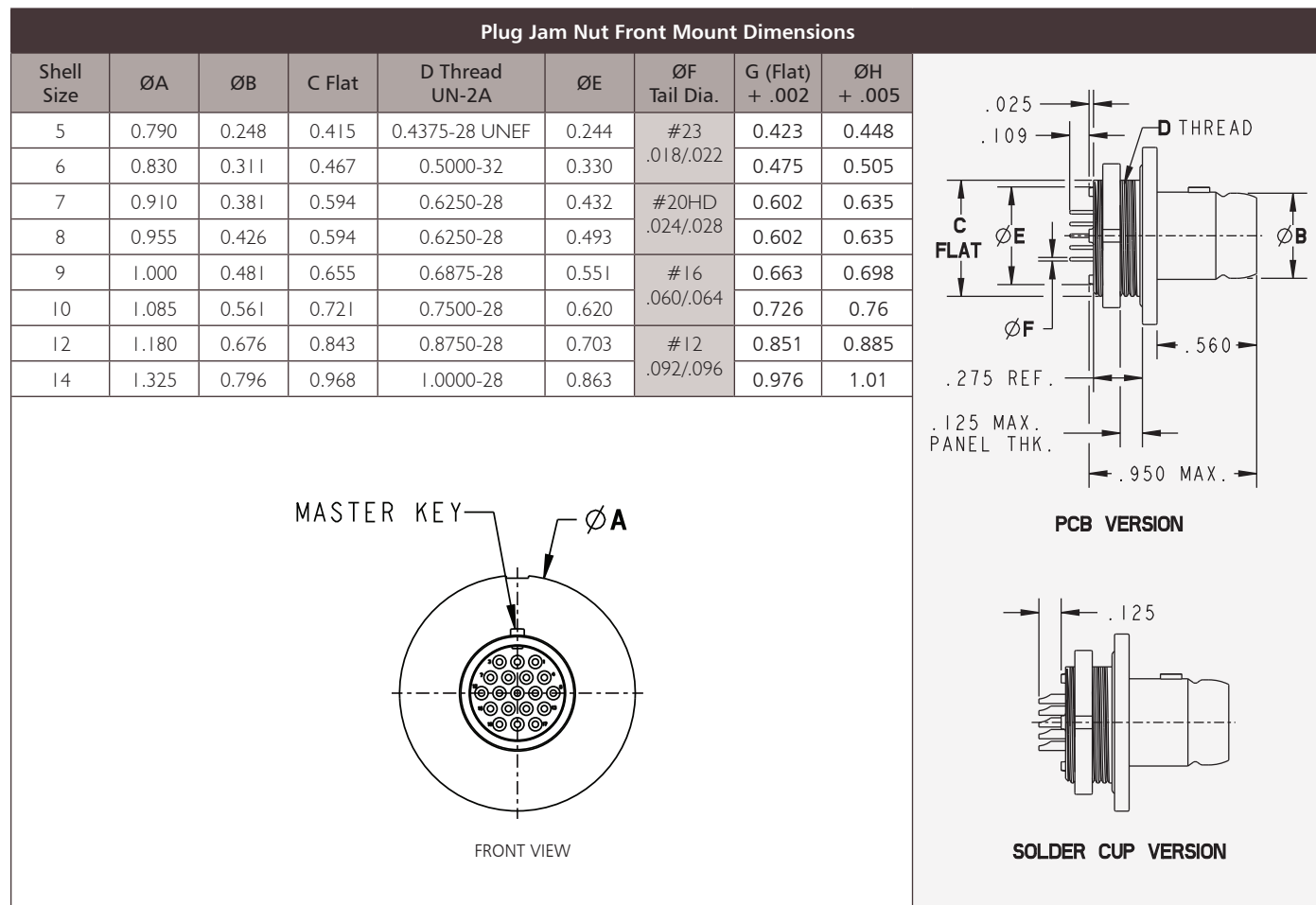

For all Shell Sizes and Clockings, the Master Keyway remains stationary at top dead center, with minor keys rotating to achieve alternate clocking positions.

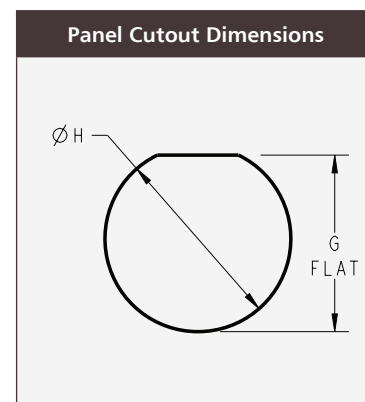
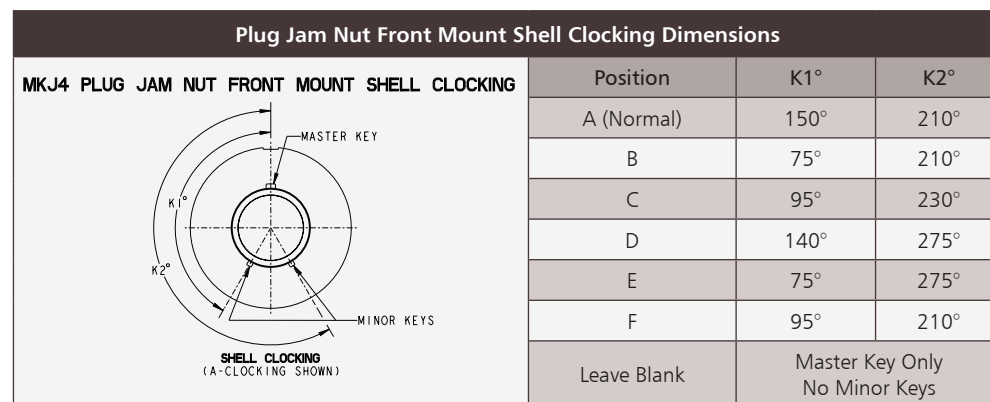

Dimensions shown in inches (mm)  
Specifications and dimensions subject to change

# MKJ4 Receptacle

In-Line Receptacle, Jam Nut Rear Mount, Jam Nut Front Mount  
Banded & Accessory Thread

**MKJ4 In-Line Receptacle (Shown with Banding/Overmolding Attachment)**



MKJ4 Receptacle with Socket Insert  
(Banding Version)

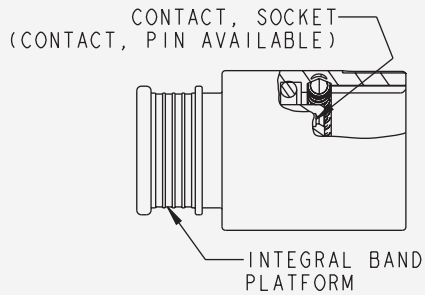

**MKJ4 Receptacle Jam Nut Rear Mount (Shown with Banding/Overmolding Attachment)**



MKJ4 Receptacle Jam Nut Rear Mount  
with Socket Insert (Banding Version)

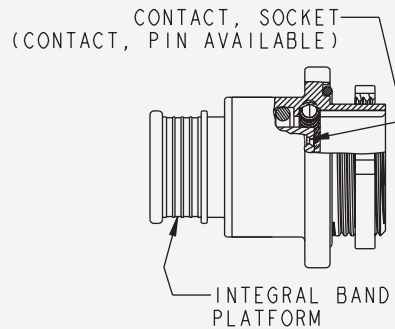

**MKJ4 Receptacle Jam Nut Front Mount (Shown with Banding/Overmolding Attachment)**



MKJ4 Receptacle Jam Nut Front Mount with  
Socket Insert (Banding Version)

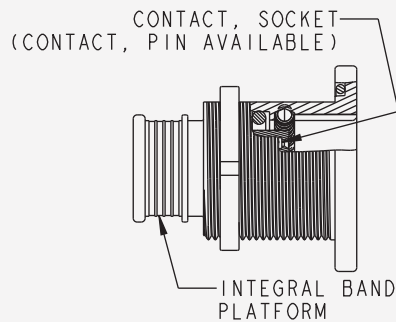

# How to Order – MKJ4 Receptacle

## In-Line Receptacle, Jam Nut Rear Mount, Jam Nut Front Mount Banded & Accessory Thread

Product	MKJ4 (Breakaway/Quick Disconnect)	MKJ4	A	1	F	9-19	P	A	**																
Class:	<table border="1"> <tr> <td>A -</td> <td>Environmental Receptacle with Banding/Overmolding Attachment</td> </tr> <tr> <td>B -</td> <td>Environmental Receptacle with Threaded Accessory Attachment</td> </tr> </table>	A -	Environmental Receptacle with Banding/Overmolding Attachment	B -	Environmental Receptacle with Threaded Accessory Attachment																				
A -	Environmental Receptacle with Banding/Overmolding Attachment																								
B -	Environmental Receptacle with Threaded Accessory Attachment																								
Shell Style:	<table border="1"> <tr> <td>1 -</td> <td>In-Line Receptacle</td> </tr> <tr> <td>7 -</td> <td>Jam Nut Receptacle-Rear Panel Mount</td> </tr> <tr> <td>8 -</td> <td>Jam Nut Receptacle-Front Panel Mount</td> </tr> </table>	1 -	In-Line Receptacle	7 -	Jam Nut Receptacle-Rear Panel Mount	8 -	Jam Nut Receptacle-Front Panel Mount																		
1 -	In-Line Receptacle																								
7 -	Jam Nut Receptacle-Rear Panel Mount																								
8 -	Jam Nut Receptacle-Front Panel Mount																								
Material/Plating:	<table border="1"> <tr> <td>C -</td> <td>Aluminum/Anodize, Black</td> </tr> <tr> <td>F -</td> <td>Aluminum/Electroless Nickel</td> </tr> <tr> <td>K -</td> <td>Stainless Steel/Passivated</td> </tr> <tr> <td>T -</td> <td>Aluminum/Teflon Nickel</td> </tr> <tr> <td>W -</td> <td>Aluminum/Olive Drab Cadmium</td> </tr> <tr> <td>Y -</td> <td>Stainless Steel/Electroless Nickel, Black</td> </tr> <tr> <td>Z -</td> <td>Aluminum/Zinc Nickel, Black</td> </tr> <tr> <td>N -</td> <td>Stainless Steel/Electroless Nickel</td> </tr> </table>	C -	Aluminum/Anodize, Black	F -	Aluminum/Electroless Nickel	K -	Stainless Steel/Passivated	T -	Aluminum/Teflon Nickel	W -	Aluminum/Olive Drab Cadmium	Y -	Stainless Steel/Electroless Nickel, Black	Z -	Aluminum/Zinc Nickel, Black	N -	Stainless Steel/Electroless Nickel								
C -	Aluminum/Anodize, Black																								
F -	Aluminum/Electroless Nickel																								
K -	Stainless Steel/Passivated																								
T -	Aluminum/Teflon Nickel																								
W -	Aluminum/Olive Drab Cadmium																								
Y -	Stainless Steel/Electroless Nickel, Black																								
Z -	Aluminum/Zinc Nickel, Black																								
N -	Stainless Steel/Electroless Nickel																								
Shell Size/Contact Arrangement:	See Available Layouts on Pages 10–11																								
Contact Style:	<table border="1"> <tr> <td>P -</td> <td>Pin, Crimp, Removable</td> </tr> <tr> <td>S -</td> <td>Socket, Crimp, Removable</td> </tr> <tr> <td>E -</td> <td>Pin, Solder Cup, Potted, Non-removable</td> </tr> <tr> <td>F -</td> <td>Socket, Solder Cup, Potted, Non-removable</td> </tr> </table>	P -	Pin, Crimp, Removable	S -	Socket, Crimp, Removable	E -	Pin, Solder Cup, Potted, Non-removable	F -	Socket, Solder Cup, Potted, Non-removable																
P -	Pin, Crimp, Removable																								
S -	Socket, Crimp, Removable																								
E -	Pin, Solder Cup, Potted, Non-removable																								
F -	Socket, Solder Cup, Potted, Non-removable																								
Shell Clocking:	<table border="1"> <tr> <td>Omit</td> <td>Single Keyway</td> </tr> <tr> <td>A -</td> <td>Normal</td> </tr> <tr> <td>B, C, D, E, F</td> <td>Alternatives</td> </tr> </table>	Omit	Single Keyway	A -	Normal	B, C, D, E, F	Alternatives																		
Omit	Single Keyway																								
A -	Normal																								
B, C, D, E, F	Alternatives																								
Modification Codes:	<table border="1"> <tr> <td>- F0</td> <td>Less Contacts ("F0" not stamped on the connector, but must be included on the P.O.)</td> </tr> <tr> <td>- F256</td> <td>Stainless Steel Hood (Socket contact only)</td> </tr> <tr> <td>- 518</td> <td>Potted connectors with water immersion testing (10<sup>-4</sup> Helium leak tested)</td> </tr> </table>	- F0	Less Contacts ("F0" not stamped on the connector, but must be included on the P.O.)	- F256	Stainless Steel Hood (Socket contact only)	- 518	Potted connectors with water immersion testing (10 <sup>-4</sup> Helium leak tested)																		
- F0	Less Contacts ("F0" not stamped on the connector, but must be included on the P.O.)																								
- F256	Stainless Steel Hood (Socket contact only)																								
- 518	Potted connectors with water immersion testing (10 <sup>-4</sup> Helium leak tested)																								

Consult factory for other modification codes



# MKJ4 Receptacle

In-Line

Banded & Accessory Thread

Cable Receptacle Dimensions			
Shell Size	ØA	ØB	C Thread UNEF-2A
5	0.450	0.246	0.2500-32
6	0.480	0.290	0.3125-32
7	0.580	0.390	0.4375-28
8	0.610	0.442	0.5000-28
9	0.695	0.500	0.5625-24
10	0.735	0.564	0.6250-24
12	0.880	0.650	0.6875-24
14	1.010	0.805	0.9375-20

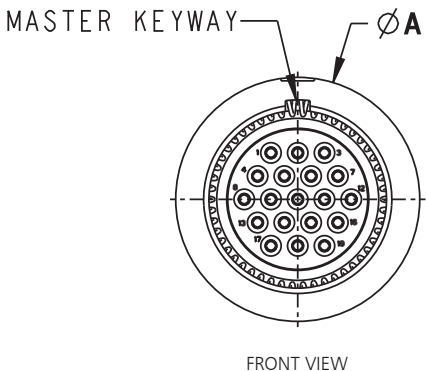

FRONT VIEW

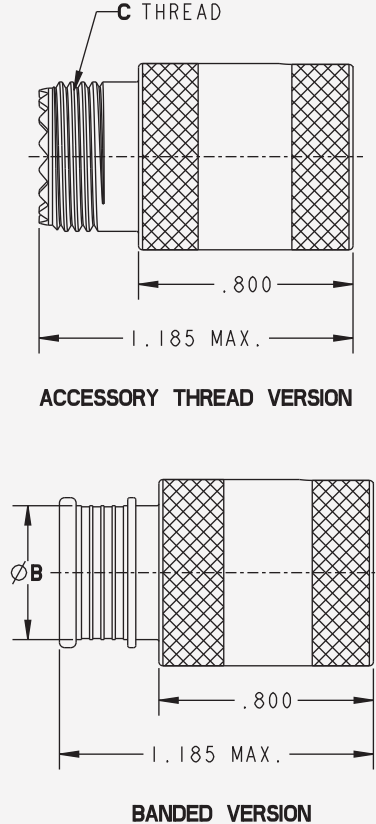

ACCESSORY THREAD VERSION

BANDED VERSION

For all Shell Sizes and Clockings, the Master Keyway remains stationary at top dead center, with minor keys rotating to achieve alternate clocking positions.

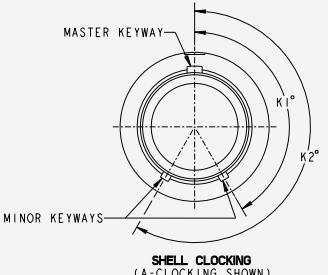
Cable Receptacle Shell Clocking Dimensions			
MKJ4 RECEPTACLE SHELL CLOCKING	Position	K1°	K2°
 <p>SHELL CLOCKING (A-CLOCKING SHOWN)</p>	A (Normal)	150°	210°
	B	75°	210°
	C	95°	230°
	D	140°	275°
	E	75°	275°
	F	95°	210°
	Leave Blank	Master Key Only No Minor Keys	

# MKJ4 Receptacle

## Jam Nut Rear Mount

## Banded & Accessory Thread

Cable Receptacle Jam Nut Rear Mount Dimensions								
Shell Size	ØA	ØB	ØC	D Flat	E Thread UN-2A	F Thread UNEF-2A	G (Flat) + .002	ØH + .005
5	0.790	0.450	0.246	0.415	0.4375-28 UNEF	0.2500-32	0.423	0.448
6	0.830	0.520	0.286	0.467	0.5000-32	0.3125-32	0.475	0.505
7	0.910	0.580	0.390	0.594	0.6250-28	0.4375-28	0.602	0.635
8	0.955	0.603	0.442	0.594	0.6250-28	0.5000-28	0.602	0.635
9	1.000	0.695	0.500	0.655	0.6875-28	0.5625-24	0.663	0.698
10	1.085	0.735	0.564	0.721	0.7500-28	0.6250-24	0.726	0.76
12	1.180	0.880	0.650	0.843	0.8750-28	0.6875-24	0.851	0.885
14	1.325	1.010	0.805	0.968	1.0000-28	0.9375-20	0.976	1.01

For all Shell Sizes and Clockings, the Master Keyway remains stationary at top dead center, with minor keys rotating to achieve alternate clocking positions.

Cable Receptacle Jam Nut Front Mount Shell Clocking Dimensions			
Position	K1°	K2°	Leave Blank
B	75°	210°	
C	95°	230°	
D	140°	275°	
E	75°	275°	
F	95°	210°	

# MKJ4 Receptacle

Jam Nut Front Mount

Banded & Accessory Thread

Cable Receptacle Jam Nut Front Mount Dimensions							
Shell Size	ØA	ØB	C Thread UNEF-2A	D Thread UN-2A	E FLAT	G (Flat) + .002	ØH + .005
5	0.830	0.246	0.2500-32	0.5000-32	0.470	0.475	0.505
6	0.885	0.286	0.3125-32	0.5625-32	0.530	0.536	0.572
7	0.995	0.390	0.4375-28	0.6875-28	0.663	0.663	0.698
8	0.995	0.442	0.5000-28	0.6875-28	0.663	0.663	0.698
9	1.075	0.500	0.5625-24	0.7500-28	0.720	0.726	0.76
10	1.140	0.564	0.6250-24	0.8125-28	0.788	0.794	0.822
12	1.340	0.650	0.6875-24	1.0000-28	0.970	0.976	1.01
14	1.390	0.805	0.9375-20	1.0625-20	1.020	1.026	1.072

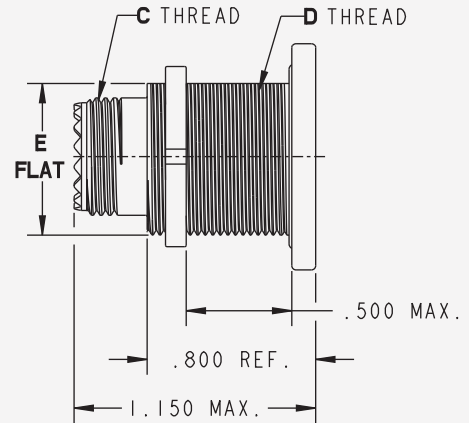
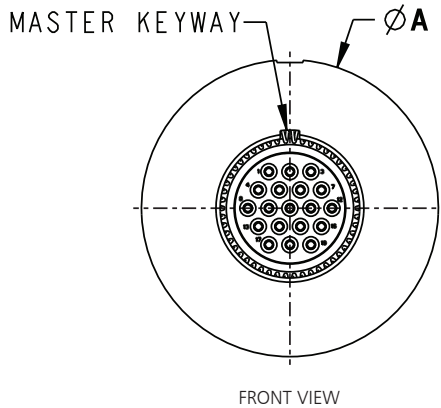

ACCESSORY THREAD VERSION

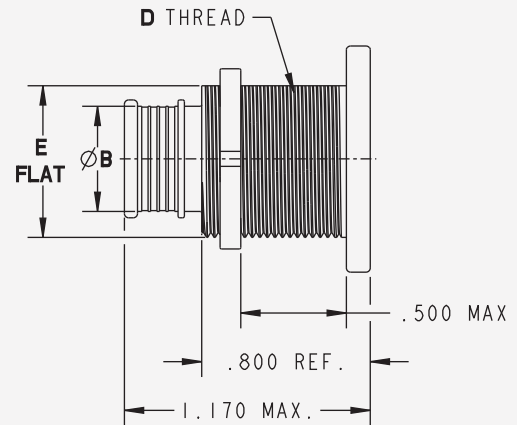

BANDED VERSION

For all Shell Sizes and Clockings, the Master Keyway remains stationary at top dead center, with minor keys rotating to achieve alternate clocking positions.

Cable Receptacle Jam Nut Front Mount Shell Clocking Dimensions			
MKJ4 RECEPTACLE JAM NUT FRONT MOUNT SHELL CLOCKING	Position	K1°	K2°
	<p>Diagram showing the shell clocking mechanism with 'MASTER KEYWAY' and 'MINOR KEYWAYS' at angles 'K1°' and 'K2°'. It is labeled 'SHELL CLOCKING (A-CLOCKING SHOWN)'.</p>	A (Normal)	150°
B		75°	210°
C		95°	230°
D		140°	275°
E		75°	275°
F		95°	210°
Leave Blank	Master Key Only No Minor Keys		

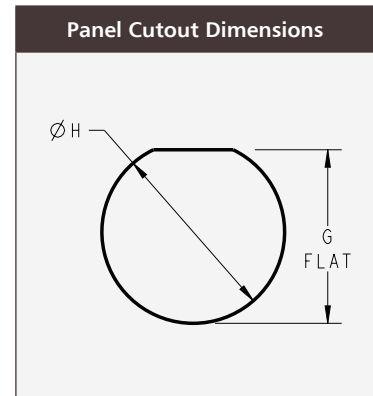

# MKJ4 Receptacle

Jam Nut Rear Mount, Jam Nut Front Mount  
PCB & Solder Cup

## MKJ4 Receptacle Jam Nut Rear Panel Mount



MKJ4 Receptacle Jam Nut Rear Panel Mount  
with Socket Insert

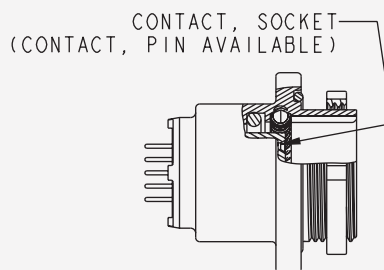

## MKJ4 Receptacle Jam Nut Front Panel Mount

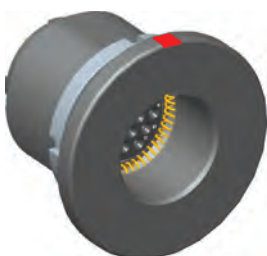

MKJ4 Receptacle Jam Nut Front Panel Mount  
with Socket Insert

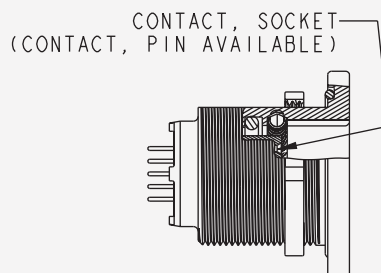

# How to Order – MKJ4 Receptacle

Jam Nut Rear Panel Mount, Jam Nut Front Panel Mount  
PCB & Solder Cup

Product	MKJ4 (Breakaway/Quick Disconnect)								
	MKJ4	C	7	F	9-19	D	A	**	
Class:	C -	Potted Receptacle - PC/Flex/Solder							
Shell Style:	7 -	Jam Nut Receptacle-Rear Panel Mount							
	8 -	Jam Nut Receptacle-Front Panel Mount							
Material/Plating:	C -	Aluminum/Anodize, Black							
	F -	Aluminum/Electroless Nickel							
	K -	Stainless Steel/Passivated							
	T -	Aluminum/Teflon Nickel							
	W -	Aluminum/Olive Drab Cadmium							
	Y -	Stainless Steel/Electroless Nickel, Black							
	Z -	Aluminum/Zinc Nickel, Black							
	N -	Stainless Steel/Electroless Nickel							
Shell Size/Contact Arrangement:	See Available Layouts on Pages 10–11								
Contact Style:	B -	Pin, PC Tail, .109 Extension, Potted, Non-removable							
	D -	Socket, PC Tail, .109 Extension, Potted, Non-removable							
	E -	Pin, Solder Cup, Potted, Non-removable							
	F -	Socket, Solder Cup, Potted, Non-removable							
Shell Clocking:	Omit	Single Keyway							
	A -	Normal							
	B, C, D, E, F	Alternatives							
Modification Codes:	- F256	Stainless Steel Hood (Socket contact only)							
	- 518	Potted connectors with water immersion testing (10 <sup>-4</sup> Helium leak tested)							

Consult factory for other modification codes



# MKJ4 Receptacle

Jam Nut Rear Panel Mount  
Potted, PCB & Solder Cup

Receptacle Jam Nut Rear Panel Mount Dimensions								
Shell Size	ØA	B Flat	ØC	ØD	E Thread UN-2A	ØF Thread Tail Dia.	G (Flat) + .002	ØH + .005
5	0.730	0.415	0.435	0.244	0.4375-28 UNEF	#23 .018/.022	0.423	0.448
6	0.730	0.467	0.493	0.330	0.5000-28 UNEF		0.475	0.505
7	0.910	0.594	0.570	0.432	0.6250-28	#20HD .024/.028	0.602	0.635
8	0.955	0.594	0.603	0.493	0.6250-28		0.602	0.635
9	1.000	0.655	0.685	0.551	0.6875-28	#16 .060/.064	0.663	0.698
10	1.085	0.721	0.735	0.620	0.7500-28		0.726	0.76
12	1.190	0.843	0.860	0.703	0.8750-28	#12 .092/.096	0.851	0.885
14	1.325	0.968	0.973	0.863	1.0000-28		0.976	1.01

FRONT VIEW

PCB VERSION

SOLDER CUP VERSION

For all Shell Sizes and Clockings, the Master Keyway remains stationary at top dead center, with minor keys rotating to achieve alternate clocking positions.

Receptacle Jam Nut Rear Panel Mount Shell Clocking Dimensions			
MKJ4 RECEPTACLE JAM NUT REAR MOUNT SHELL CLOCKING	Position	K1°	K2°
		A (Normal)	150°
B		75°	210°
C		95°	230°
D		140°	275°
E		75°	275°
F		95°	210°
Leave Blank	Master Key Only No Minor Keys		

Panel Cutout Dimensions

# MKJ4 Receptacle

Jam Nut Front Panel Mount  
Potted, PCB & Solder Cup

Receptacle Jam Nut Front Panel Mount Dimensions							
Shell Size	ØA	B Flat	ØC	D Thread UN-2A	ØE Tail Dia.	G (Flat) + .002	ØH + .005
5	0.830	0.470	0.244	0.5000-28 UNEF	#23	0.475	0.505
6	0.885	0.530	0.330	0.5625-32	.018/.022	0.536	0.572
7	0.995	0.663	0.432	0.6875-28	#20HD	0.663	0.698
8	0.995	0.663	0.493	0.6875-28	.024/.028	0.663	0.698
9	1.075	0.720	0.551	0.7500-28	#16	0.726	0.76
10	1.140	0.788	0.620	0.8125-28	.060/.064	0.794	0.822
12	1.340	0.970	0.703	1.0000-28	#12	0.976	1.01
14	1.390	1.020	0.863	1.0625-20	.092/.096	1.026	1.072

MASTER KEYWAY

ØA

FRONT VIEW

D THREAD

.025

.109

B FLAT

ØC

ØE

.800 REF.

.945 MAX.

.300 MAX. PANEL THK

PCB VERSION

SOLDER CUP VERSION

.125

For all Shell Sizes and Clockings, the Master Keyway remains stationary at top dead center, with minor keys rotating to achieve alternate clocking positions.

Receptacle Jam Nut Front Panel Mount Shell Clocking Dimensions			
MKJ4 RECEPTACLE JAM NUT FRONT PANEL MOUNT SHELL CLOCKING	Position	K1°	K2°
	<p>MASTER KEYWAY</p> <p>MINOR KEYWAYS</p> <p>SHELL CLOCKING (A-CLOCKING SHOWN)</p>	A (Normal)	150°
B		75°	210°
C		95°	230°
D		140°	275°
E		75°	275°
F		95°	210°
Leave Blank	Master Key Only No Minor Keys		

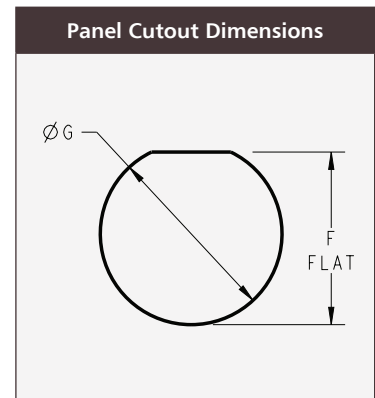

# MKJ4 Weight Charts

MKJ4 Connector Weight in Grams				
Pin Layout	Plug	Jam Nut Receptacle Rear Mount	Jam Nut Receptacle Front Mount	In-Line Receptacle
5-3P	1.8	8.0	9.4	4.3
6-1P	2.5	7.2	11.6	5.7
6-4P	2.2	8.7	11.3	5.2
6-6P	2.2	8.7	11.2	5.2
6-7P	2.4	9.0	11.4	5.8
6-23P	2.7	8.8	11.3	3.9
7-1P	3.4	11.0	16.0	8.1
7-25P	3.2	10.9	15.8	8.0
7-10P	3.4	10.8	15.8	8.0
8-2P	4.6	10.8	22.3	6.4
8-28P	4.8	11.0	23.0	6.6
8-13P	4.0	10.5	12.5	5.9
9-4P	5.3	15.1	20.6	8.8
9-210P	5.5	14.9	20.4	8.3
9-19P	4.3	14.0	19.9	10.1
10-2P	6.5	15.1	22.4	8.4
10-5P	6.8	15.4	22.6	8.6
10-26P	5.0	13.5	20.6	7.3
12-2P	9.9	21.4	25.6	15.0
12-3P	10.8	22.3	26.5	15.7
12-7P	11.0	22.6	26.7	15.8
12-220P	10.7	22.2	26.3	15.6
12-37P	8.5	21.4	25.2	16.1
14-5P	13.0	28.1	32.9	18.9
14-12P	13.7	28.8	33.5	19.5
14-235P	13.3	28.4	33.1	19.2
14-55P	10.8	25.4	30.4	17.1

MKJ4 Connector Weight in Grams				
Socket Layout	Plug	Jam Nut Receptacle Rear Mount	Jam Nut Receptacle Front Mount	In-Line Receptacle
5-3S	1.9	8.2	9.7	4.5
6-1S	2.7	7.5	12.1	6.0
6-4S	2.4	8.9	11.5	5.5
6-6S	2.5	9.1	11.7	5.7
6-7S	2.6	9.4	11.9	6.0
6-23S	3.3	9.2	11.8	4.3
7-1S	4.0	11.6	16.8	8.6
7-25S	3.9	11.6	16.8	8.6
7-10S	3.9	11.2	16.4	8.3
8-2S	5.3	5.7	11.7	7.2
8-28S	5.7	6.2	12.9	7.6
8-13S	4.4	10.9	12.9	6.5
9-4S	6.2	16.1	22.0	9.6
9-210S	6.2	16.1	22.0	9.6
9-19S	4.4	14.8	21.0	10.2
10-2S	7.7	16.4	24.3	9.3
10-5S	8.1	16.8	24.7	9.6
10-26S	5.7	13.8	21.0	7.6
12-2S	11.4	23.0	27.6	16.1
12-3S	12.4	24.1	28.7	16.9
12-7S	13.4	25.1	29.7	17.7
12-220S	12.8	24.4	29.0	17.2
12-37S	10.0	23.0	27.1	15.9
14-5S	15.6	31.0	36.3	21.1
14-12S	16.8	32.5	37.8	22.1
14-235S	16.8	32.4	37.7	22.1
14-55S	13.2	28.1	33.6	19.1

## Crimp Contacts

Pin Contacts (Size 23) 030-9649-000  
 Socket contacts (Size 23) 031-9750-000



## Contact Area Plating:

50 Micro inches Gold over Nickel  
 Accommodates Sizes #22-28 AWG Wire

## Crimp Tool

Contact Crimp Tool 995-0002-293  
 Locator 995-0002-297



## Contact Insertion/Extraction Tools

Insertion Tool 995-0002-295  
 Extraction Tool 995-0002-294

## Banding Tools

Hand banding Tool 995-0002-298  
 1/8" bands (100 pk) 995-0002-299



## Banding Tools

PART NUMBER	USE ON JAMNUT SIZE / PN
317-2187-000	MKJ1 (6) MKJ0 (7)
317-2187-001	MKJ1 (7) MKJ0 (9)
317-2187-002	MKJ1 (9)
317-2187-003	MKJ1 (13)
317-2187-006	MKJ0 (6)
317-2187-007	MKJ0 (12)



## Backshells

**MKJB S - 7 - 6 - W**

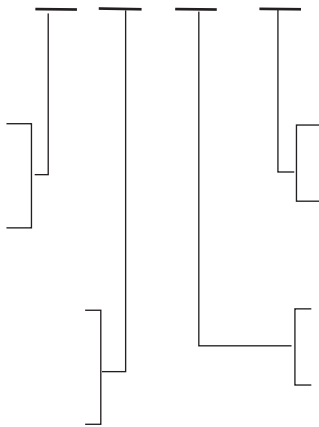

Shell Material: 6061-T6 Aluminum

**Clamp**

**Straight**

**90°**



**Backshell Designator Table**

Backshell Designator	1	2	3	4		5		6		7		8	
Shell Style	MKJ0, MKJ1, MKJ3, MKJ4	MKJ0, MKJ1, MKJ3, MKJ4	MKJ5	MKJ0, MKJ1, MKJ3, MKJ4	MKJ5	MKJ0, MKJ1, MKJ3, MKJ4	MKJ5	MKJ0, MKJ1, MKJ3, MKJ4	MKJ5	MKJ0, MKJ1, MKJ3, MKJ4	MKJ5	MKJ0, MKJ1, MKJ3, MKJ4	MKJ5
Shell Size	(05) Straight	(06) Straight	(08) Straight	(07) Straight	(09) Straight	(08) Straight	(10) Straight	(09) Straight	(11) Straight	(10) Straight	(12) Straight	(12) Straight	(13) Straight

## Heat Shrink Boot

Material: Fluid resistant elastomer

Adhesive: Polyamide hot melt

### MKJ Heat Shrink Boot P/N's - Straight

Shell Size	ITT P/N
5, 6, 7	980-2010-017
8, 9	980-2010-018
10, 11, 12, 13	980-2010-019

### MKJ Heat Shrink Boot P/N's - 90°

Shell Size	ITT P/N
5, 6, 7	980-2010-020
8, 9	980-2010-021
10, 11, 12, 13	980-2010-022

## Metal Dust Caps

### MKJ Aluminum Dustcap Designator- Talking Dog

**MKJD 1 - 7 - P - F**

Shell Style  
0, 1, 3, 4, 5

Shell Size  
5, 6, 7, 8, 9,  
11, 12, 13

**Plating**

W= OD Cad  
F = Nickel  
Z = Black Zinc Nickel

**Gender**

P= Plug  
R= Receptacle

Shell Material: Alluminum Alloy



No Size 11 or 12 dustcaps are available on MKJ1  
No size 11 or 13 dustcaps are available on MKJ0, MKJ3, & MKJ4  
No size 5, 6, 7, or 13 dustcaps are available on MKJ5

# Cables to Outfit Your MKJ Connector

Value-Added MKJ Series Cabling Solutions from ITT Cannon



Let ITT Cannon complete your MKJ solution with our custom cable products. A complement to the reduction in size of the connectors is the reduction in weight and thickness in cabling. Choose from several available options to help customize your application. Improving on our high reliability connectors, we offer overmolds that are suitable for military requirements in harsh environments.



# About ITT Cannon

ITT is a diversified leading manufacturer of highly engineered critical components and customized technology solutions for industrial end-markets in energy infrastructure, electronics, aerospace and transportation. Building on its heritage of innovation, ITT partners with its customers to deliver enduring solutions to the key industries that underpin our modern way of life. Founded in 1920, ITT is headquartered in White Plains, N.Y., with employees in more than 35 countries and sales in approximately 125 countries.

Our connector portfolio remains the most extensive in the industry, offering a reliable and cost effective range of interconnect solutions. Continuous investment in technology and research & development have enabled ITT to provide new, innovative products and solutions to markets including:

- Commercial Aviation
- Defense
- Oil & Gas
- Industrial
- Medical
- Space Exploration

When you specify a Cannon connector, you can rely on products that are designed, developed, and manufactured to the highest quality and reliability standards. This tradition of excellence is based on ITT's corporate culture of operating its businesses under the principles of Six Sigma. At ITT, Six Sigma is not just a quality philosophy but a complete corporate culture that drives the entire business. Our Value Based Management and Value Based Product Development systems are two cornerstones that allow for the development of both leadership and product engineering principles, ensuring our industry leading products are developed to the accepted market driven lead times. These principles have allowed ITT to become the market leader in all of our business portfolios.

## Six Sigma Manufacturing

ITT Cannon operates manufacturing facilities in the United States, Germany, Italy, Mexico, China and Japan, all of which have particular product area strengths allowing ITT to offer a truly global footprint to our customers. Our facilities are world class and accommodate full vertical integration utilizing the latest manufacturing technologies including: automated and robotic machining centers, Super Market manufacturing cells, Kanban pull systems, and automated electrical, mechanical, and optical test and inspection equipment. The combination of

our manufacturing strength and our advanced manufacturing facilities allows ITT to offer products at market driven prices. Our capabilities, especially in robotics, computerized precision tooling, Kaizen Project Management, Six Sigma tools, and testing, give ITT the most optimized global manufacturing footprint in the interconnect industry.

## The Custom Difference

As the industry leader in harsh environment interconnect applications, ITT's world class engineering teams will work directly with our customers to design and develop cost effective solutions for their applications. In many cases we may modify one of our standard designs to ensure a highly reliable solution where timing is critical. When custom connectors are required, we collaborate with clients and partners with a goal to design the most reliable, cost-effective solution possible. As professional consultants, our Engineering teams will provide a thorough systems and mechanical analysis of any proposed solution. These analyses provide our customers with sophisticated electrical signal and mechanical characterizations to determine the best solution for their application.

## RoHS Compliance Information

ITT has implemented a strict parts control plan for all ITT electronics plants worldwide that allows the Cannon product portfolio to meet the requirements of the European Union Directive 2002/95/EC better known as the Reduction of Hazardous Substances initiative. As appropriate, specific Cannon products may be ordered with an R prefix number which insures our customers will receive RoHS compliant parts for their commercial electronics applications and equipment. Since most RoHS hazardous substances center around specific metal plating and lead solder coatings, ITT's products for RoHS compliance are available in the following plating finishes: electroless nickel, stainless steel, anodize over aluminum and gold plating. It should be noted that gold plating would be recommended as the replacement for tin-lead solder when ordering board mount connectors.



# Product Safety

## 1. Material Content and Physical Form

Electrical connectors do not usually contain hazardous materials. They contain conducting and non-conducting materials and can be divided into two groups.

- a) Printed circuit types and low cost audio types which employ all plastic insulators and casings.
- b) Rugged, Fire Barrier and High Reliability types with metal casings and either natural rubber, synthetic rubber, plastic or glass insulating materials. Contact materials vary with type of connector and also application and are usually manufactured from either: Copper, copper alloys, nickel, alumel, chromel or steel. In special applications, other alloys may be specified.

### **CAUTION**

## 2. Fire Characteristics And Electric Shock Hazard

There is no fire hazard when the connector is correctly wired and used within the specified parameters. Incorrect wiring or assembly of the connector or careless use of metal tools or conductive fluids, or transit damage to any of the component parts may cause electric shock or burns. Live circuits must not be broken by separating mated connectors as this may cause arcing, ionization and burning. Heat dissipation is greater at maximum resistance in a circuit. Hot spots may occur when resistance is raised locally by damage, e.g. cracked or deformed contacts, broken strands of wire. Local overheating may also result from the use of the incorrect application tools or from poor quality soldering or slack screw terminals. Overheating may occur if the ratings in the product Data Sheet/ Catalog are exceeded and can cause breakdown of insulation and hence electric shock. If heating is allowed to continue it intensifies by further increasing the local resistance through loss of temper of spring contacts, formation of oxide film on contacts and wires and leakage currents through carbonization of insulation and tracking paths. Fire can then result in the presence of combustible materials and this may release noxious fumes. Overheating may not be visually apparent. Burns may result from touching overheated components.

## 3. Handling

Care must be taken to avoid damage to any component parts of electrical connectors during installation and use. Although there are normally no sharp edges, care must be taken when handling certain components to avoid injury to fingers. Electrical connectors may be damaged in transit to the customers, and damage may result in creation of hazards. Products should therefore be examined prior to installation/use and rejected if found to be damaged.

## 4. Disposal

Incineration of certain materials may release noxious or even toxic fumes.

## 5. Application

Connectors with exposed contacts should not be selected for use on the current supply side of an electrical circuit, because an electric shock could result from touching exposed contacts on an unmated connector. Voltages in excess of 30 V ac or 42.5 V dc are potentially hazardous and care should be taken to ensure that such voltages cannot be transmitted in any way to exposed metal parts of the connector body. The connector and wiring should be checked, before making live, to have no damage to metal parts or insulators,

no solder blobs, loose strands, conducting lubricants, swarf, or any other undesired conducting particles. Circuit resistance and continuity check should be made to make certain that there are no high resistance joints or spurious conducting paths. Always use the correct application tools as specified in the Data Sheet/Catalog. Do not permit untrained personnel to wire, assemble or tamper with connectors. For operation voltage please see appropriate national regulations.

### Important General Information

- (i) Air and creepage paths/Operating voltage. The admissible operating voltages depend on the individual applications and the valid national and other applicable safety regulations. For this reason the air and creepage path data are only reference values. Observe reduction of air and creepage paths due to PC board and/or harnessing.
- (ii) Temperature
  - All information given are temperature limits. The operation temperature depends on the individual application.
- (iii) Other important information
  - ITT Cannon continuously endeavors to improve their products. Therefore, Cannon products may deviate from the description, technical data and shape as shown in this catalog and data sheets.

ITT Cannon, is a division of ITT Corporation who manufactures the highest quality products available in the marketplace; however these products are intended to be used in accordance with the specifications in this publication. Any use or application that deviates from the stated operating specifications is not recommended and may be unsafe. No information and data contained in this publication shall be construed to create any liability on the part of ITT Cannon. Any new issue of this publication shall automatically invalidate and supersede any and all previous issues.



# Meet Some of Our Most Innovative Connectors

## D-Subminiature Connectors

Originally designed for aircraft radio systems, Cannon's D-Subminiature Connector became the first multi-purpose interconnect solution of its kind, ideal for multiple markets and applications. From rocket launches and satellite systems, to rugged military transports and commercial avionics, the D-Subminiature's versatility has made this Cannon invention the most widely used connector in the world.

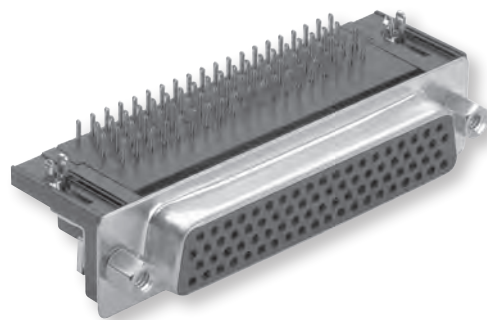

## Rack & Panel Connectors

Pioneered by Cannon during the 1930s, our Rack & Panel Connectors offer an unmatched variety of shell configurations and insert arrangements, as well as materials, plating and contact options. Today, we are recognized as an industry leader, offering an unparalleled range of off-the-shelf and custom Rack & Panel products to align with customer needs.



## Microminiature Connectors

Developed first by Cannon in the 1960s, Microminiature Connectors offer high performance and reliability with exceptional versatility. Available in rectangular, circular and strip-style configurations for countless applications, many of our highly engineered Microminiature connector products meet critical customer demands in multiple applications across the Aerospace & Defense industry.

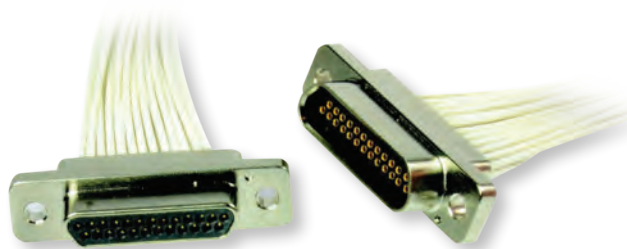

Connect with your ITT Cannon  
representative today or visit us at  
[www.ittcannon.com](http://www.ittcannon.com)

## Connect with the experts.

Whether communicating with our soldiers in the field or with first responders saving lives, ITT Cannon connects vital information with those who need it.



**CHINA—Shenzhen City**

+86.755.2726.7888

**JAPAN—Kanagawa**

+81.462.57.2010

**USA—Watertown, CT**

+1.860.274.9681

**GERMANY—Weinstadt**

+49.7151.699.0

**KOREA—Seoul**

+82.2.7027111

**HONG KONG**

+852.2732.2720

**TAIWAN—Taipei**

+886.2.25452020

**ITALY—Lainate**

+39.02938721

**UK—Basingstoke**

+44.1256.311200

**USA—Irvine, CA**

+1.800.854.3028