

Ole Wolff virtual prototyping

SoundHub Nov. 23. 2022

Per Christian Sejersbøl Jensen, R&D and application engineer

- Company introduction
- Product development cycle
- Modelling micro speakers
- Speaker system design
- Head- and earphones



Ole Wolff Electronics

- Established in 1983
- Acoustics & Magnetics
- Sales offices in Europe, USA and Asia
- Development in DK and China
- Production facilities in China
- Headquarter in Sorø, Denmark



OLE WOLFF



OLE WOLFF

owolff.com

Ole Wolff Electronics

- Development and production of microspeakers for a broad range of products
- Application support – help customers integrate our drivers in their end products



Traditional product development cycle

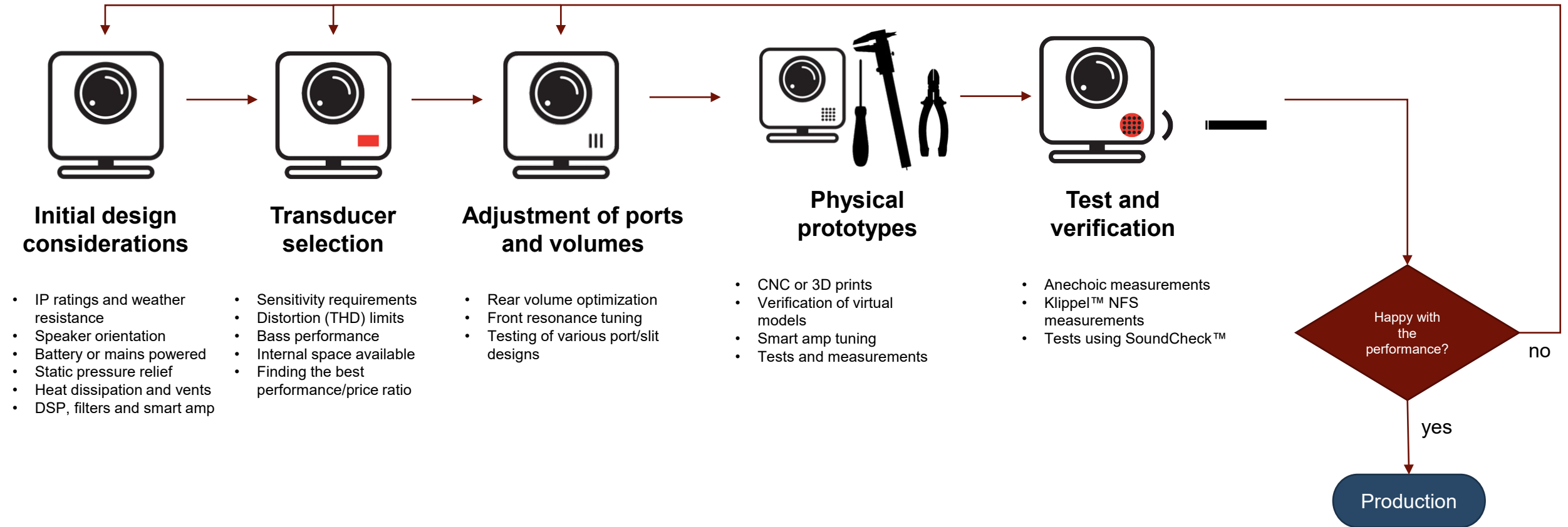

Ole Wolff simulation product development cycle

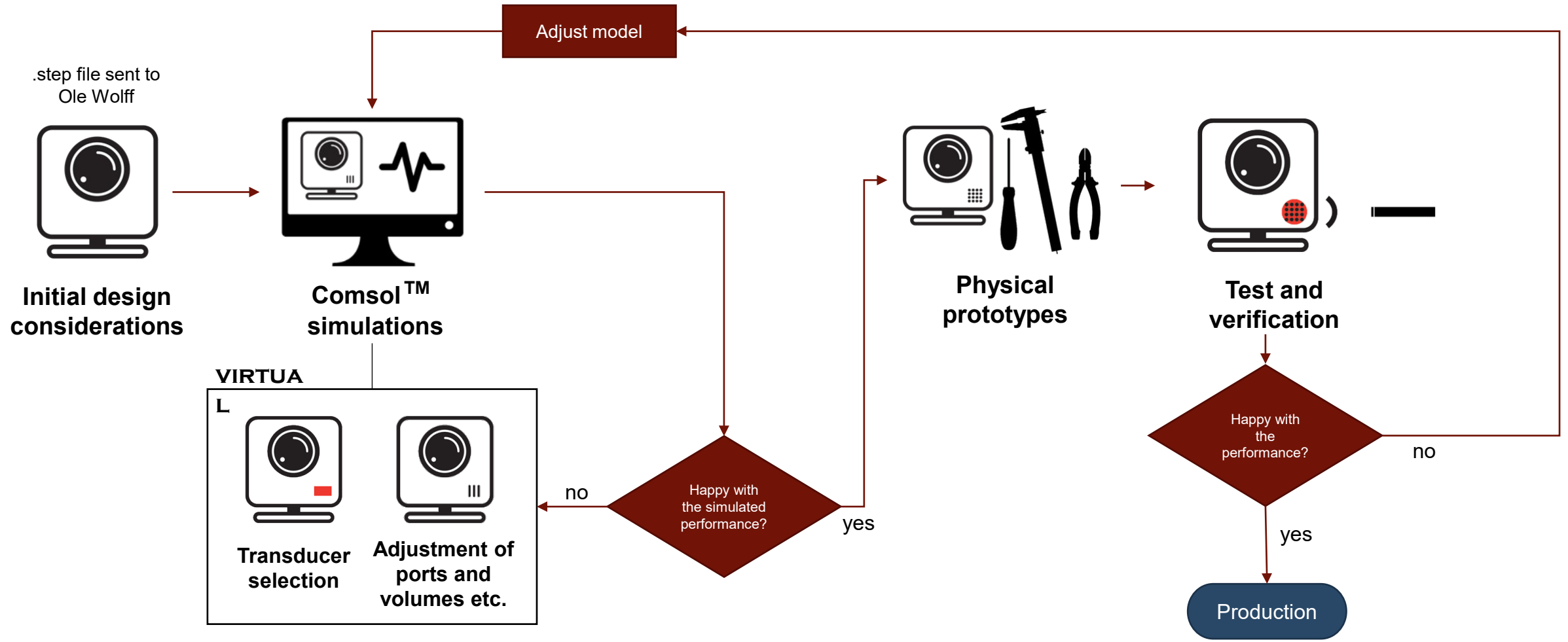

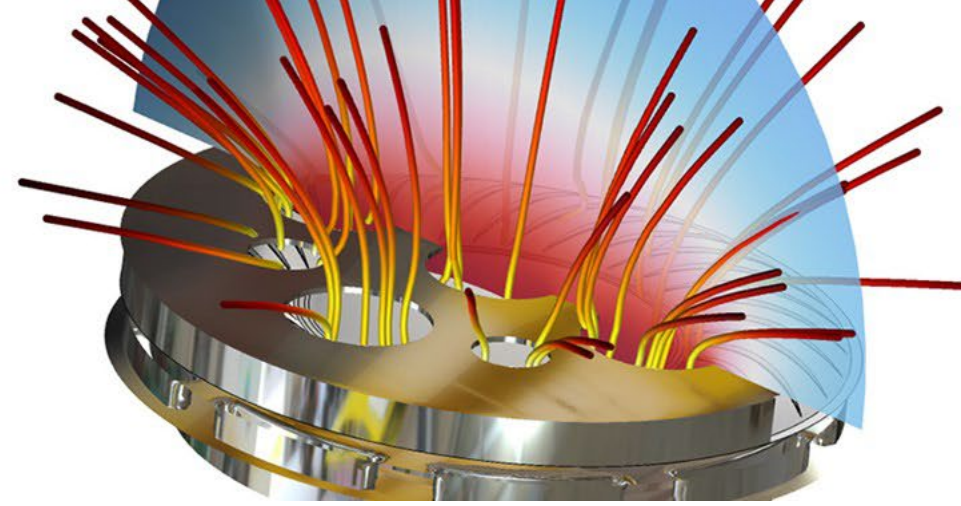
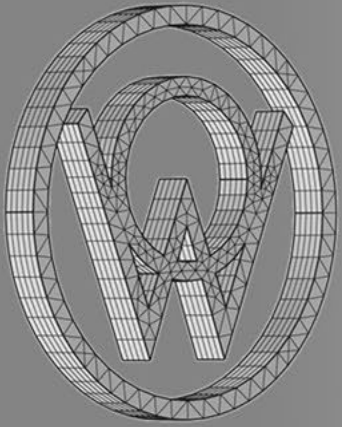

Ole Wolff has been using COMSOL® since 2016

- COMSOL® for simulations
- Klippel analyzers, SoundCheck, artificial ears, anechoic chamber, HATS etc. for verification.

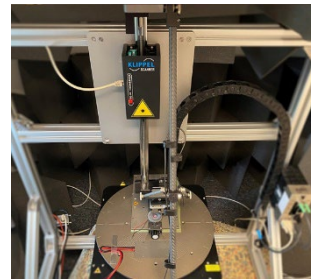
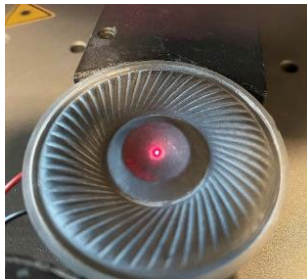

Modelling micro speakers

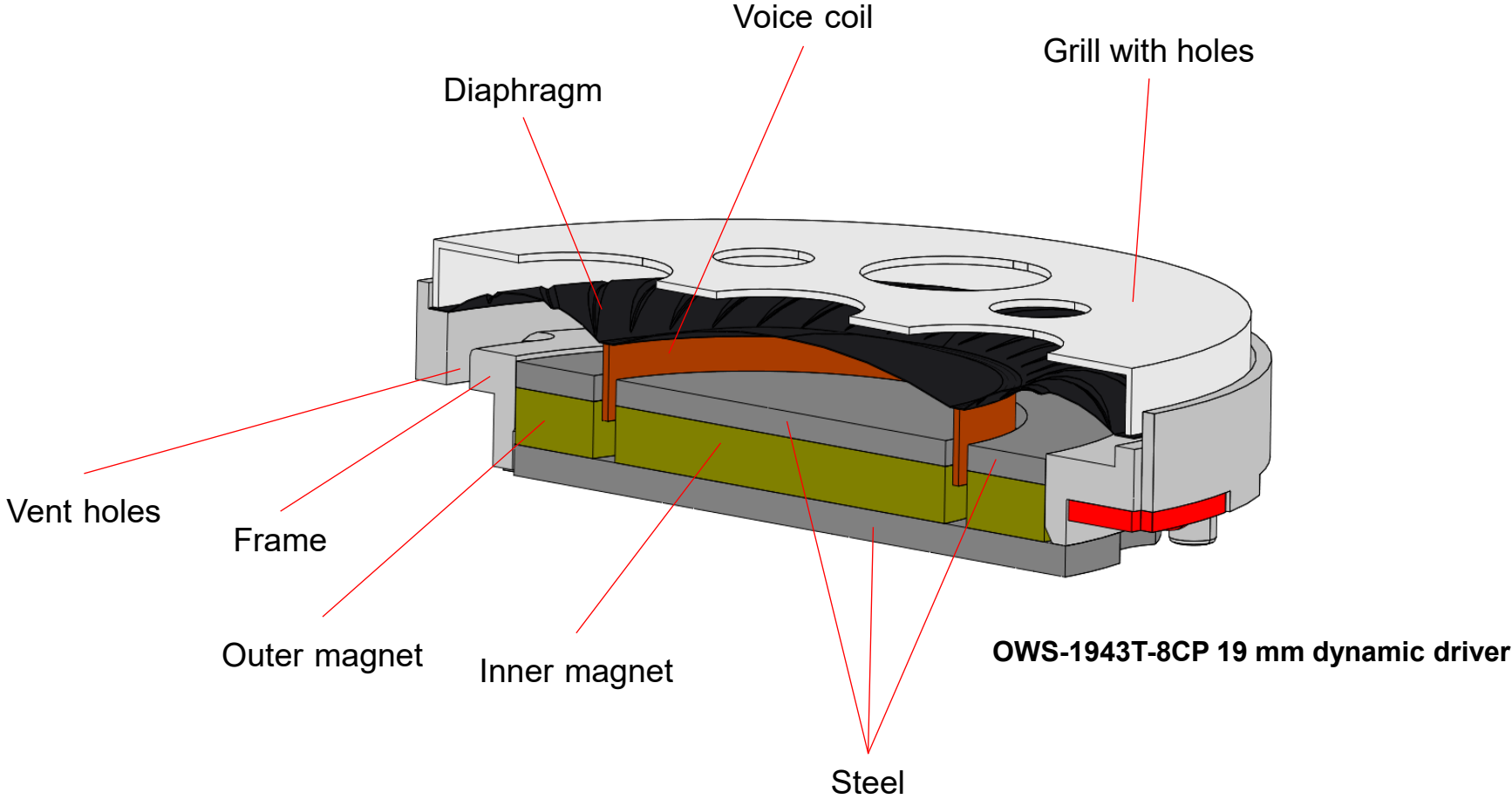

Modelling micro speakers

- **Magnetic analysis**
 - Derive $BL(x)$
 - Coil properties
- **Mechanical analysis**
 - Derive $Cms(x)$
 - View stresses on diaphragm
- **Acoustic analysis**



The Ole Wolff OWS-1943T-8CP (discontinued) driver is included in the Comsol library

OWS-1943T-8CP

Magnetic analysis (1/4)

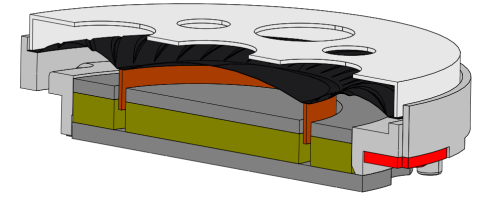

Axisymmetric simulation includes:

- Losses in steel
- Thin low permeability gaps between iron and magnets due to glue

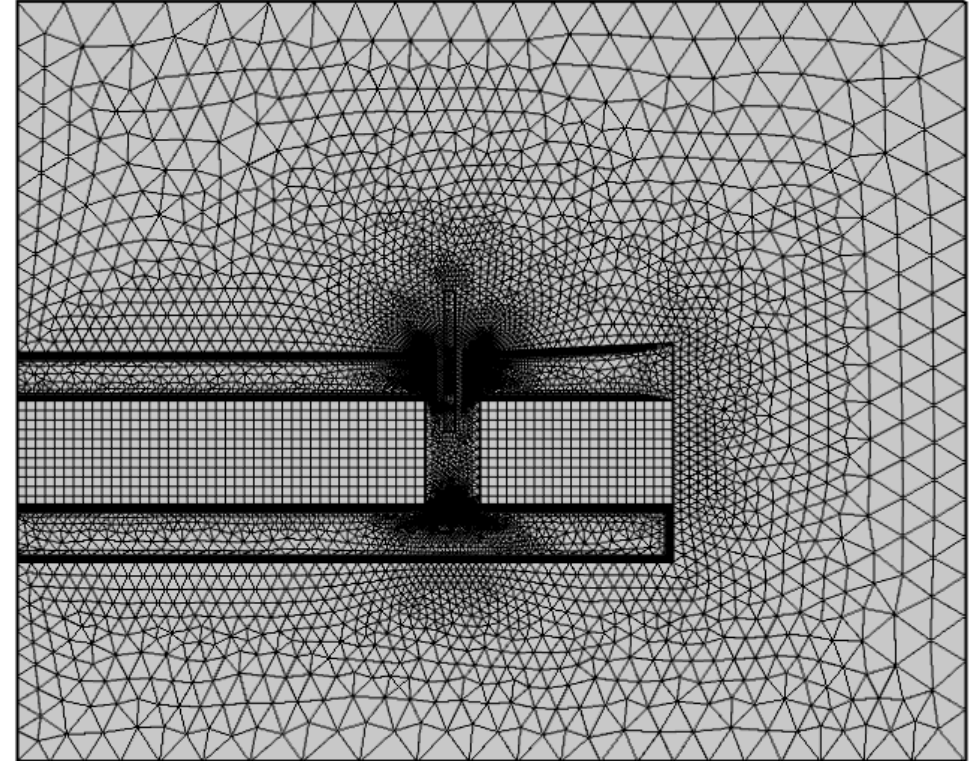

OWS-1943T-8CP

Magnetic analysis (2/4)

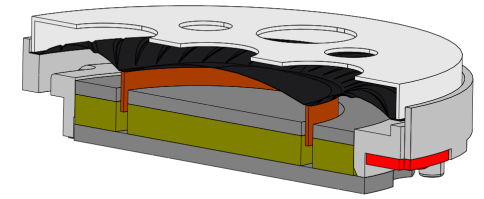

2D plots provide information about

- Static flux density
- Induced current density at various frequencies
- Saturation of steel
- Also very useful for optimizing magnet and iron for performance and cost.

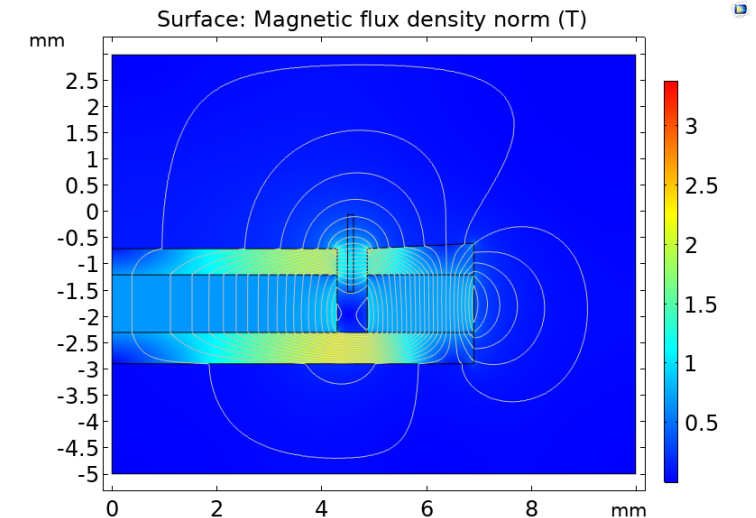
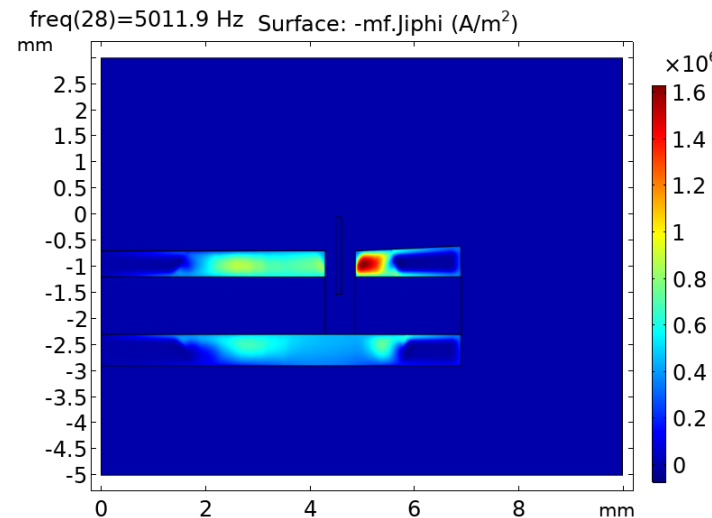

OWS-1943T-8CP

Magnetic analysis (3/4)

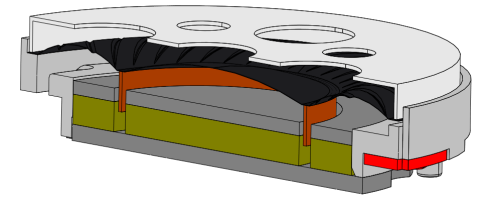

Coil resistance and reactance as function of frequency is derived. These analysis results are later used as lumped parameters in the acoustic analysis.

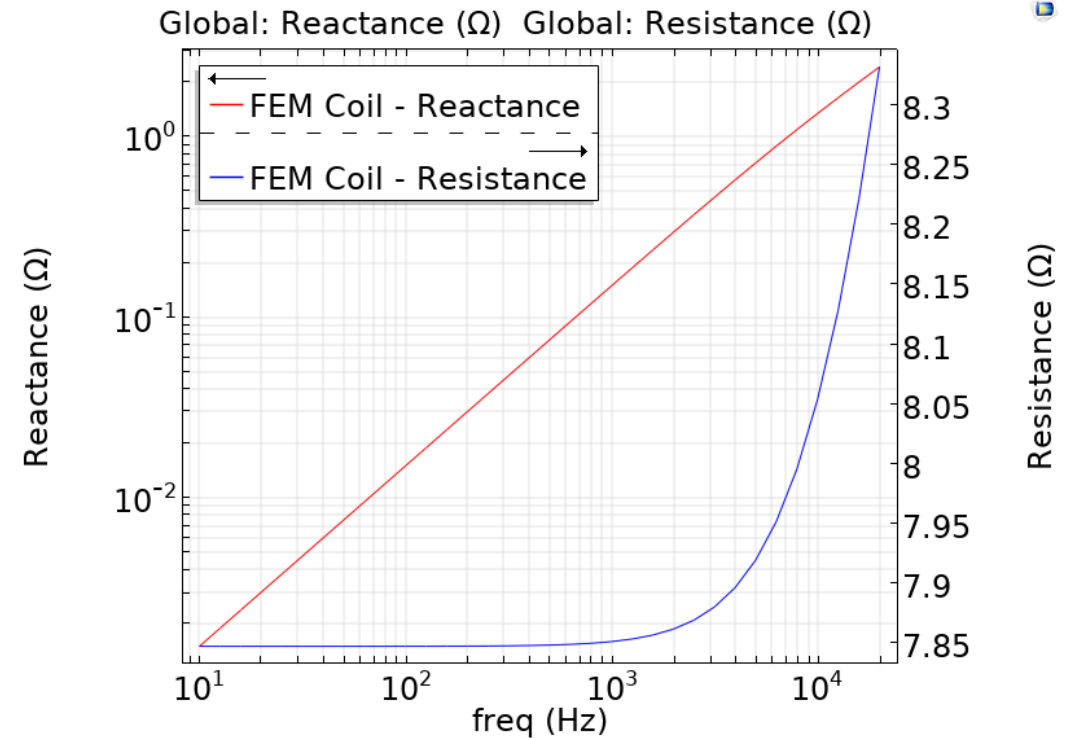

OWS-1943T-8CP

Magnetic analysis (4/4)

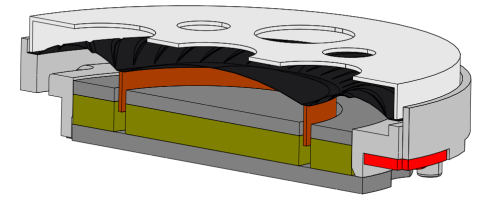

The BL(x) plot is very close to the measured Klippel response and reveals that the voice coil is slightly off-center.

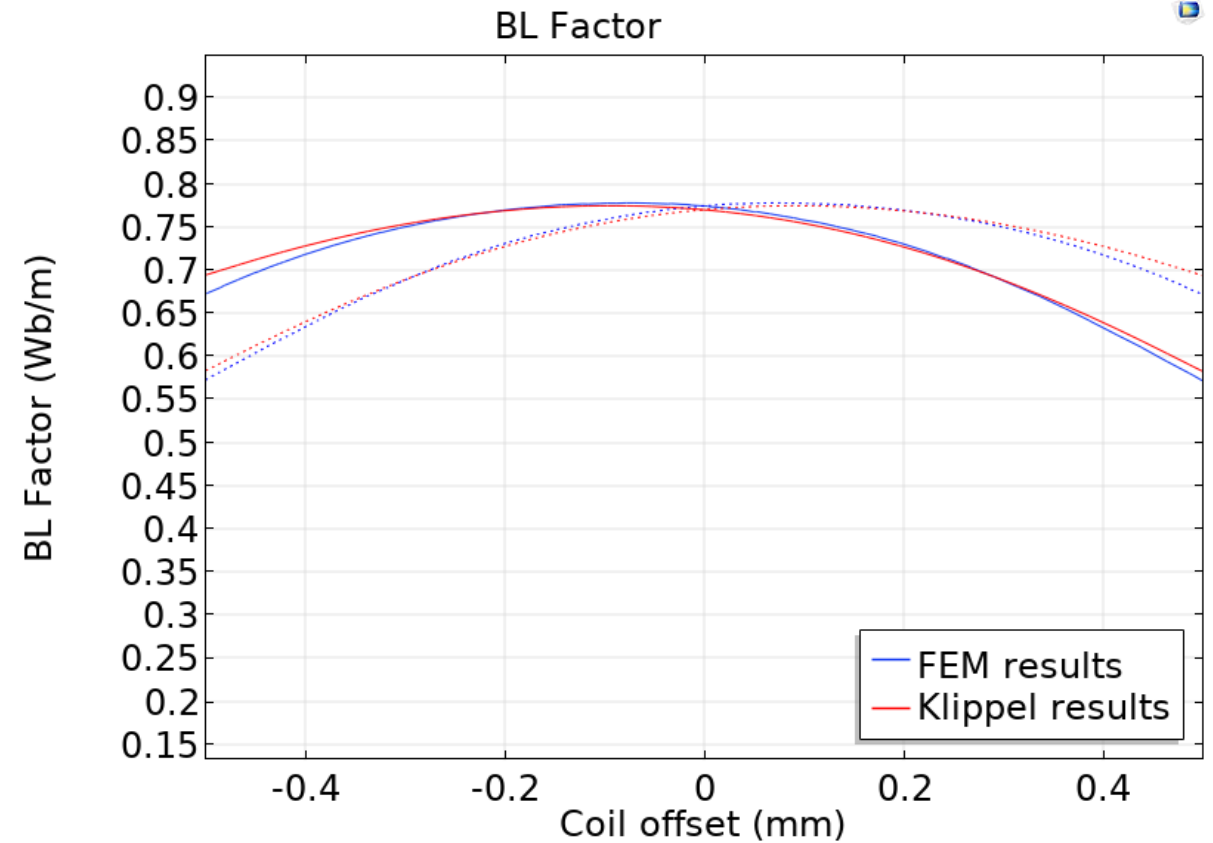

OWS-1943T-8CP

Mechanical analysis (1/2)



The diaphragm is modelled using a combination of Solid Mechanics for the voice coil and Shell physics using geometric nonlinearities for the diaphragm.

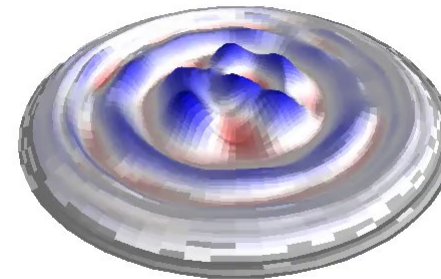

Paper, 16.5 kHz
Center part of cone is breaking up

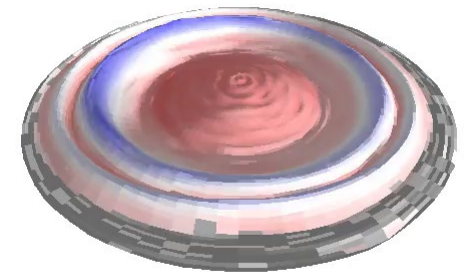

Graphene, 16.5 kHz
Center part of cone remains stiff

OWS-1943T-8CP

Mechanical analysis (2/2)

The cms analysis has pretty good agreement with the Klippel data.

Correlation between simulation and test data will always depend on the initial accuracy of the CAD file and production tolerances of the tested unit.

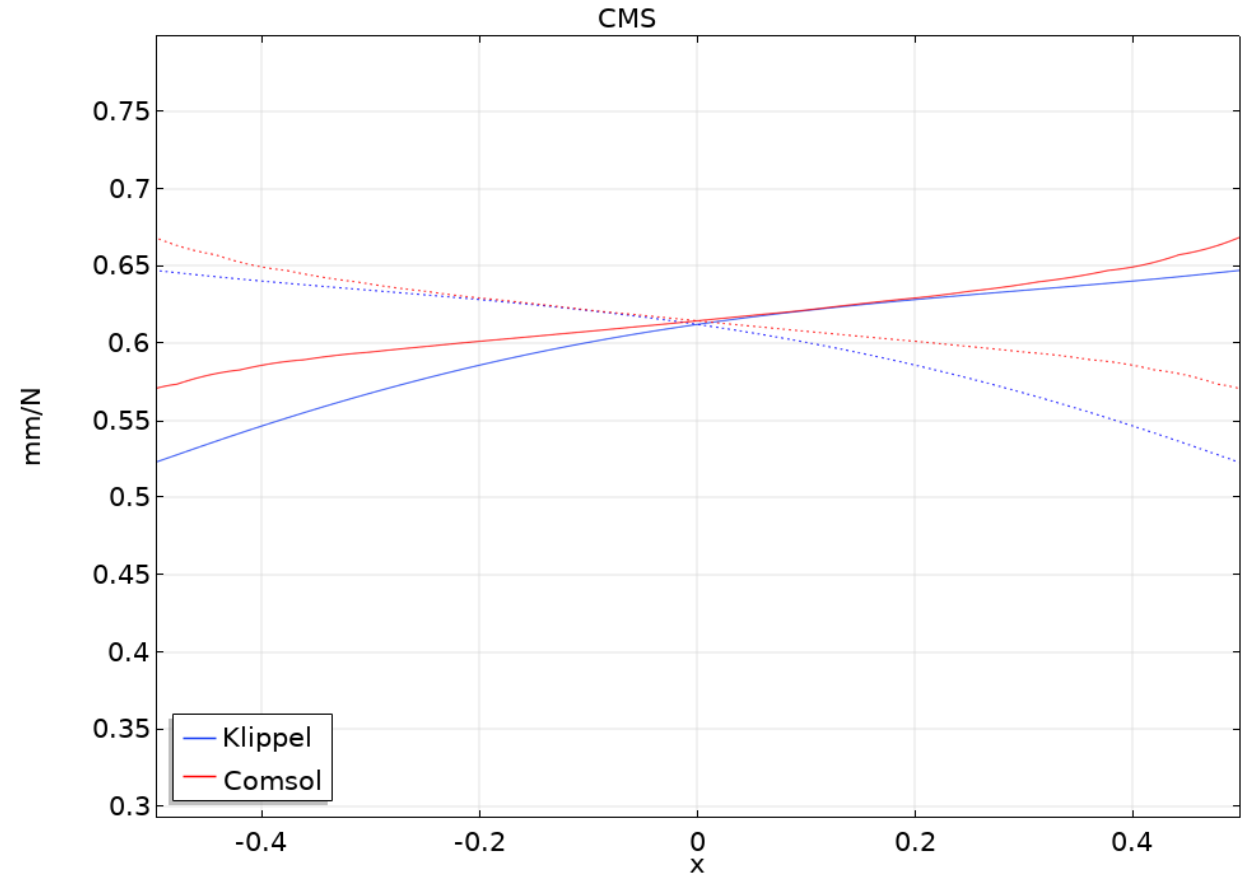





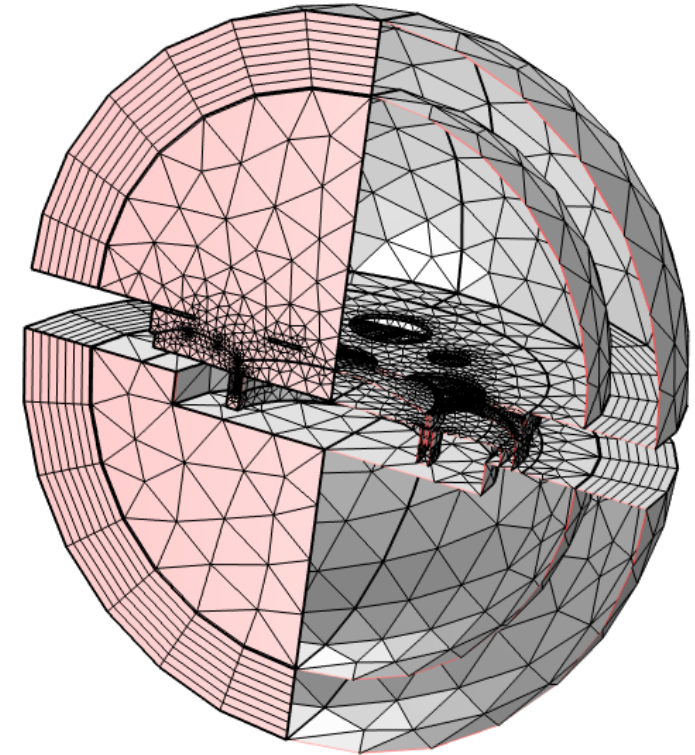

OWS-1943T-8CP

Acoustic analysis (1/3)

The acoustic analysis is performed using the following physics:

- Solid and Shell mechanics (for the diaphragm and voice coil)
- Electrical Circuit (for lumped parameters)
- Pressure acoustics
- Solid-Shell connection (for the diaphragm and voice coil)
- Acoustic-Structure boundary x2 (couples the diaphragm and voice coil to the air)
- In the pressure acoustics study, the front grill, rear holes and casing is set up as sound hard boundaries, to take internal resonances into account.



-  Pressure Acoustics, Frequency Domain (*acpr*) {*acpr*}
-  Solid Mechanics (*solid*) {*solid*}
-  Shell (*shell*) {*shell*}
-  Electrical Circuit (*cir*) {*cir*}
-  Multiphysics

OWS-1943T-8CP

Acoustic analysis (2/3)

The lumped motor of the speaker couples the voice coil impedance as well as the (static) BL value found in the magnetic study to the force on the voice coil in the mechanical study using the relation

$$\text{Force} = \text{BL} \cdot i$$

Feedback to the motor is ensured via the voltage source with the voltage defined as $\text{BL} \cdot v_0$, with v_0 being the voice coil velocity.

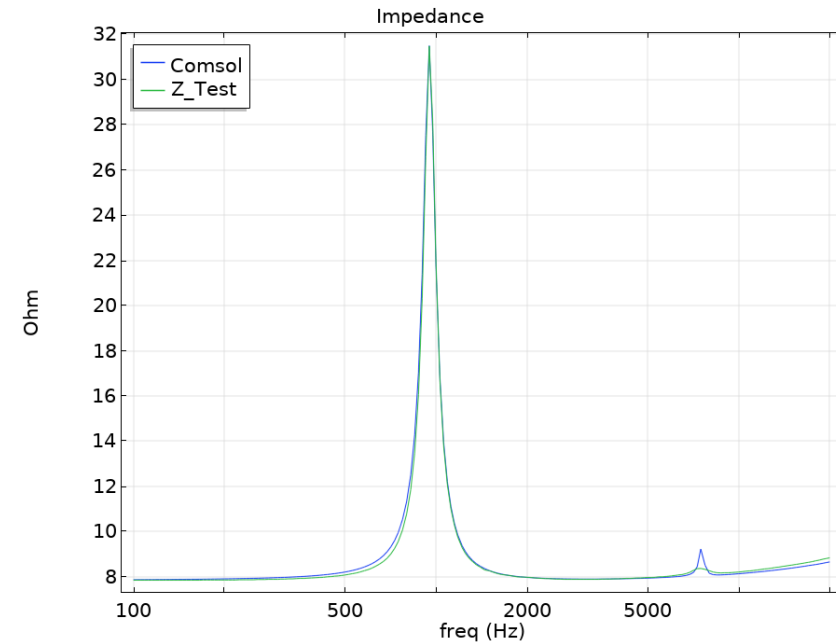
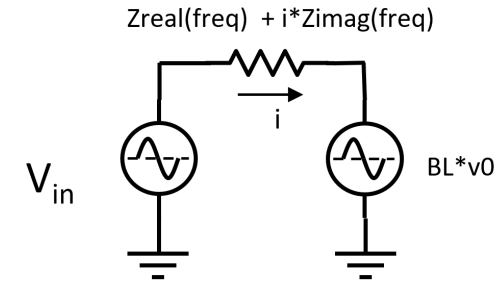

Simulated impedance curve shows very good agreement with test results. The rear hole resonance is visible at around 7.7 kHz due to the feedback to the lumped motor.

OWS-1943T-8CP

Acoustic analysis (3/3)

The sensitivity plot shows very good agreement with the measurement.

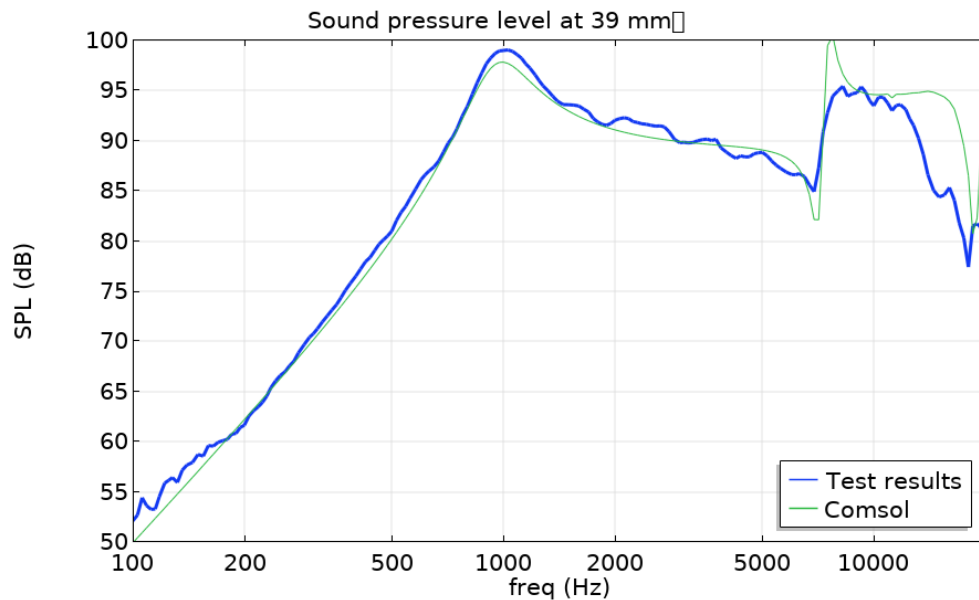

Using the Acoustic-structure physics, diaphragm breakups and rocking modes are included in the acoustic analysis.

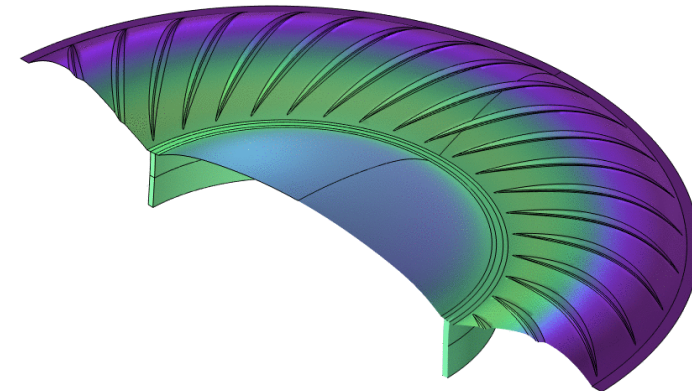

Modelling micro speakers using both lumped mechanical and electrical parameters



40mm headphone driver

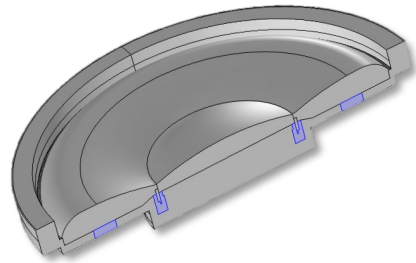

13x18 mm microspeaker

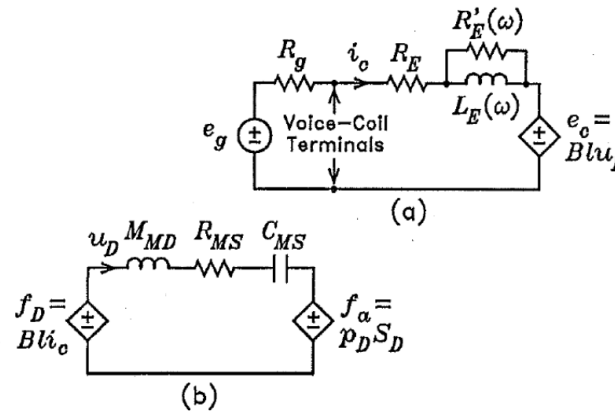
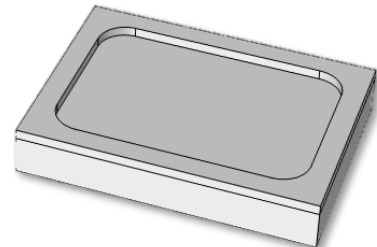

No mechanical parts are being simulated – walls are 100% rigid (no absorption / transmission).

TS parameters (from Klippel)

Name	Expression	Value
R_E	6.34[ohm]	6.34 Ω
L_e	0.028[mH]	2.8E-5 H
L2	0.005[mH]	5E-6 H
R2	0.37[ohm]	0.37 Ω
M_MD	0.071[g]	7.1E-5 kg
R_MS	0.126[kg/s]	0.126 kg/s
C_MS	0.732[mm/N]	7.32E-4 s ² /kg
BL	0.838[T*m]	0.838 Wb/m
S_D	143[mm^2]	1.43E-4 m ²
Fs	1/(2*pi*sqrt(C_MS*M_MS))	688.66 1/s
M_MS	M_MD+2*S_D^2*8*rho0/(3*...)	7.2965E-5 kg
Q_ES	2*pi*Fs*M_MS*R_E/BL^2	2.8504
Q_MS	2*pi*Fs*M_MS/R_MS	2.5057
Q_TS	Q_MS*Q_ES/(Q_MS+Q_ES)	1.3335
V_AS	rho0*c0^2*S_D^2*C_MS	2.1133E-6 m ³

- ▶ Pressure Acoustics, Frequency Domain (*acpr*)
- ▶ Electrical Circuit (*cir*)
- ▶ Thermoviscous Acoustics, Frequency Domain

System integration

Initial design considerations

- For best results: consider the acoustics early in the design process!

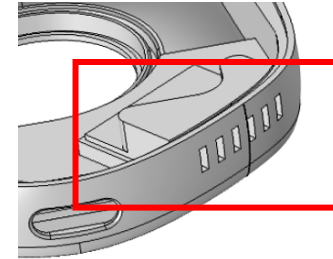

Side porting

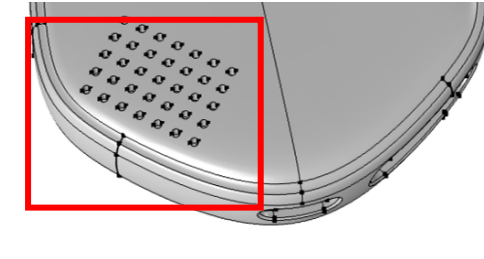

Front porting

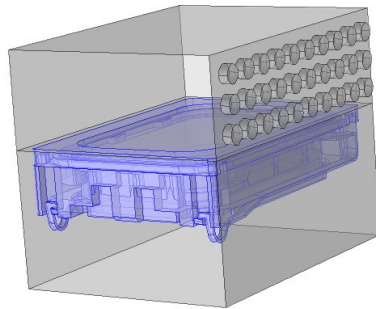

Side porting

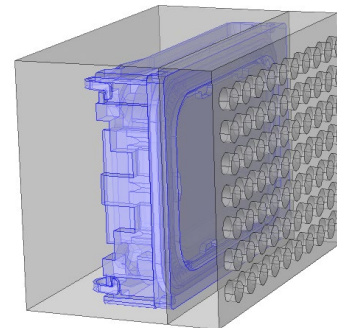

Front porting

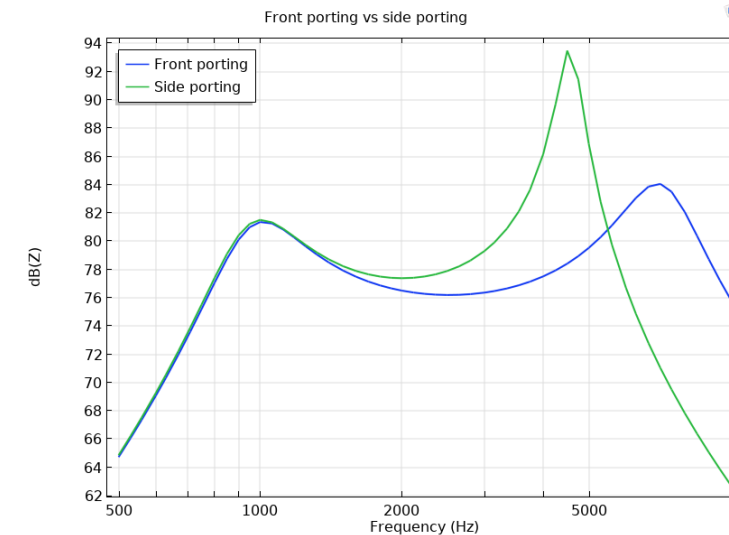

Microspeaker application example 1

IoT device with 13x18mm microspeaker (1/4)

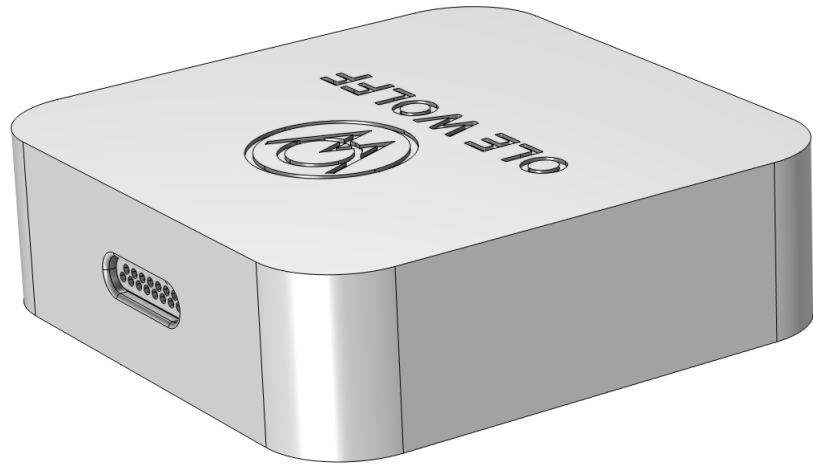

CAD sent to Ole Wolff

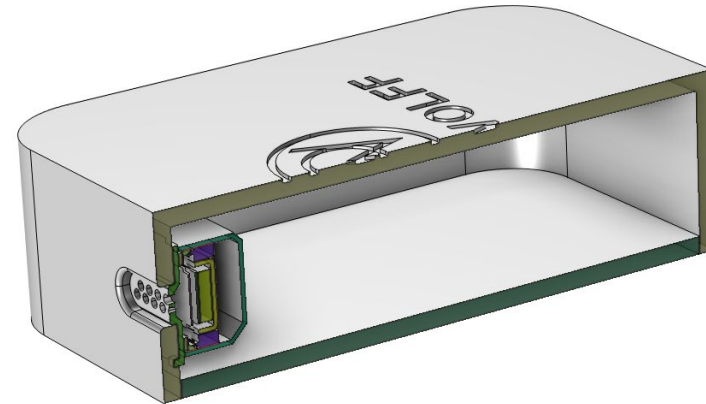

CAD only has to contain parts relevant to the acoustics – Pcb's, electrical components etc. can be omitted.

Microspeaker application example 1

IoT device with 13x18mm microspeaker (2/4)

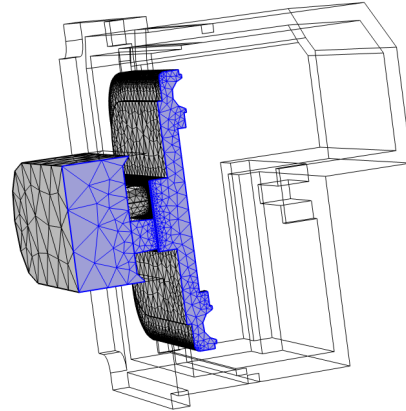
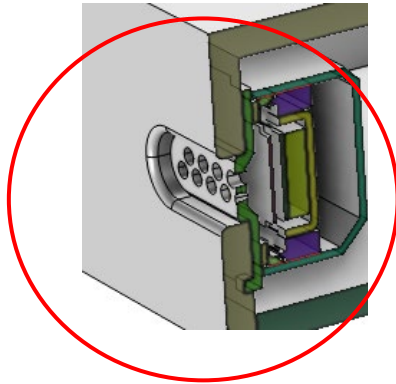

Air volume in front of speaker. Symmetry used (reduced simulation time).

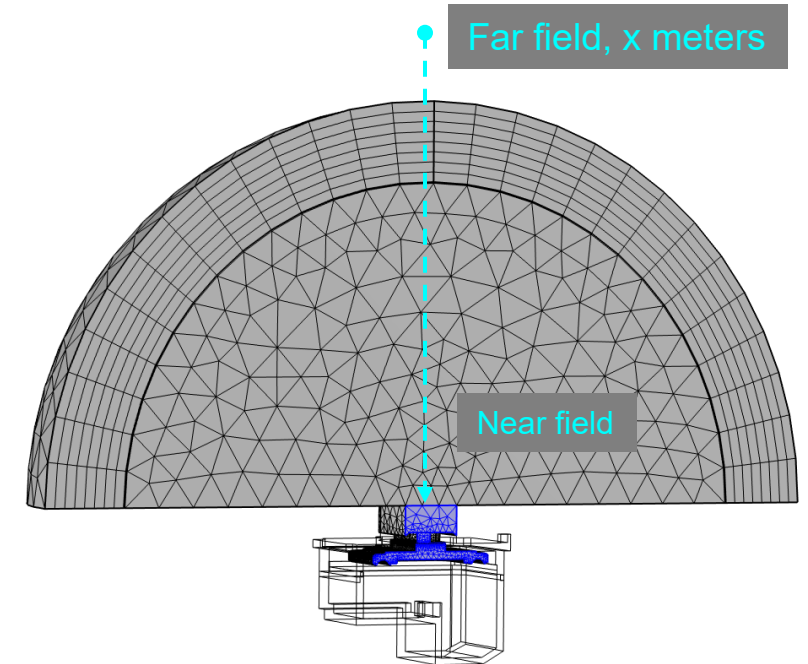

- By using a "lumped speaker boundary" only the air volume in front of the driver needs to be modelled
- Reduced complexity means lower calculation time (typ. <20mins for 0.1-15kHz, 1/12 oct.)

- Typically the speakers are simulated in an "infinite baffle", anechoic conditions
- Pressure can be evaluated anywhere in the near field or far field

Microspeaker application example 1

IoT device with 13x18mm microspeaker, (3/4)

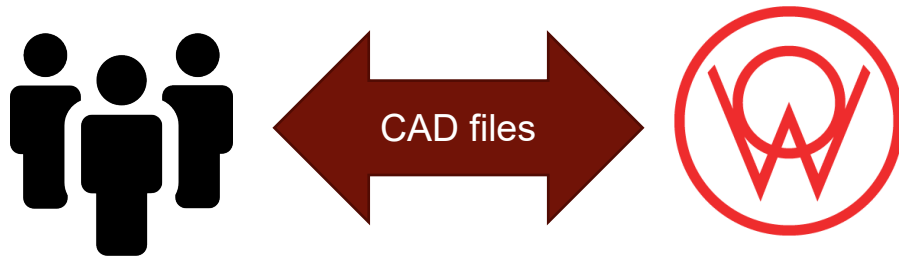

- CAD files are exchanged between OW and the customer's team.
- Effect of design adjustments can be tested "in the box" without doing any physical prototypes

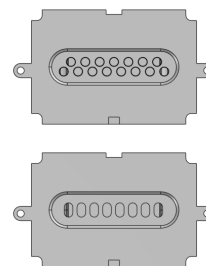
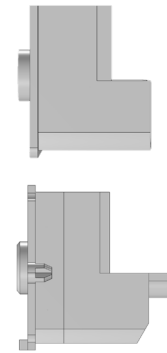

1cc vs. 0.8cc rear volume

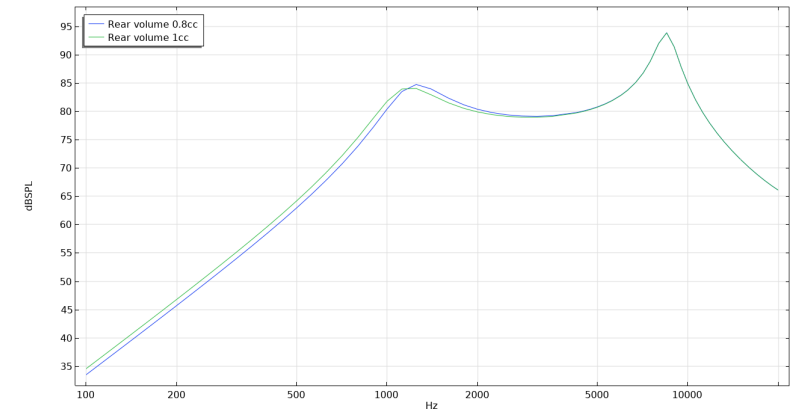

Circular vs. oval outlet holes

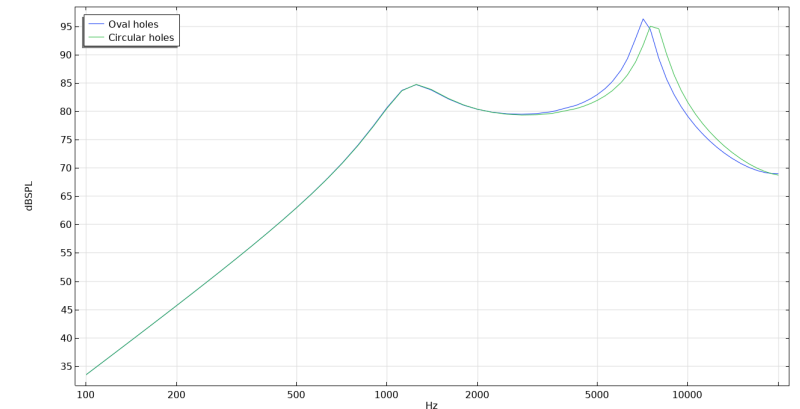

Microspeaker application example 1

IoT device with 13x18mm microspeaker, (4/4)

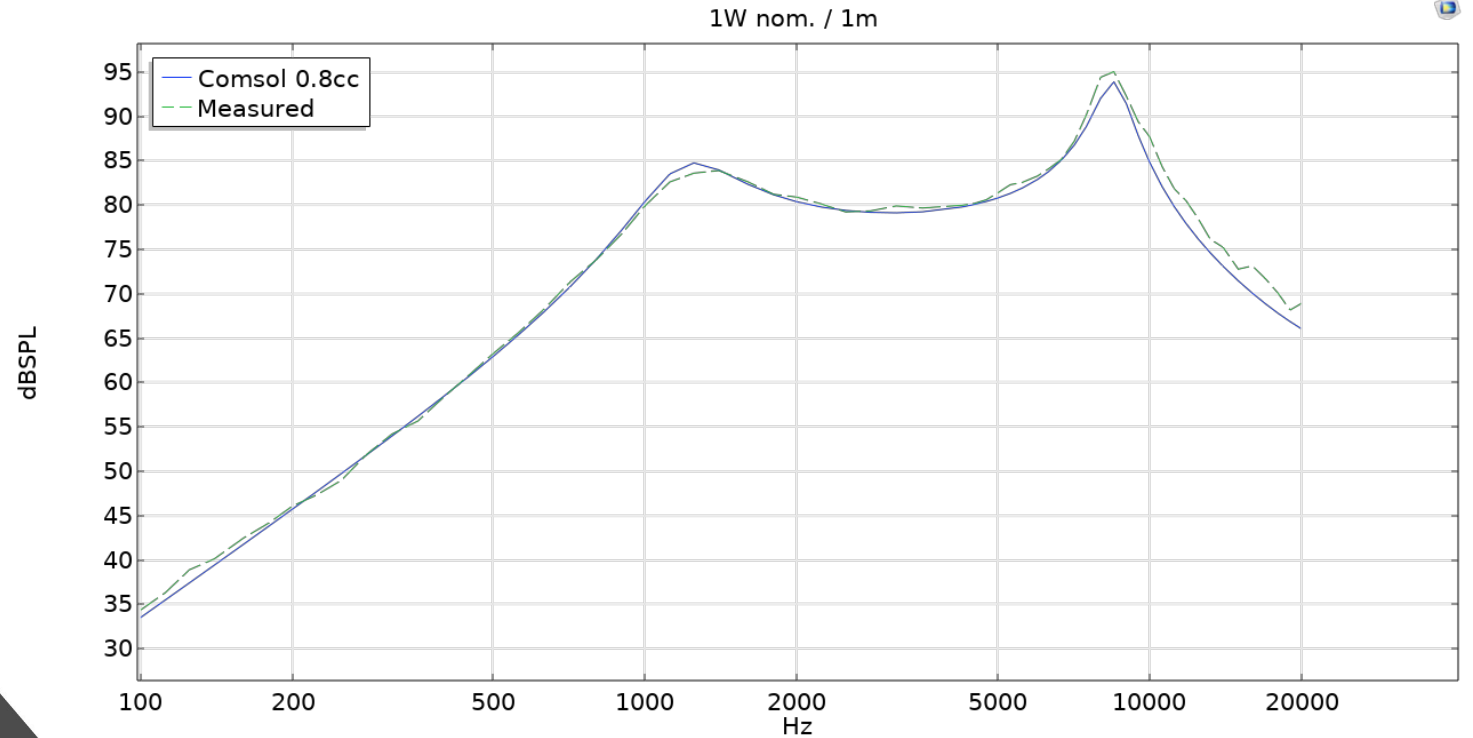
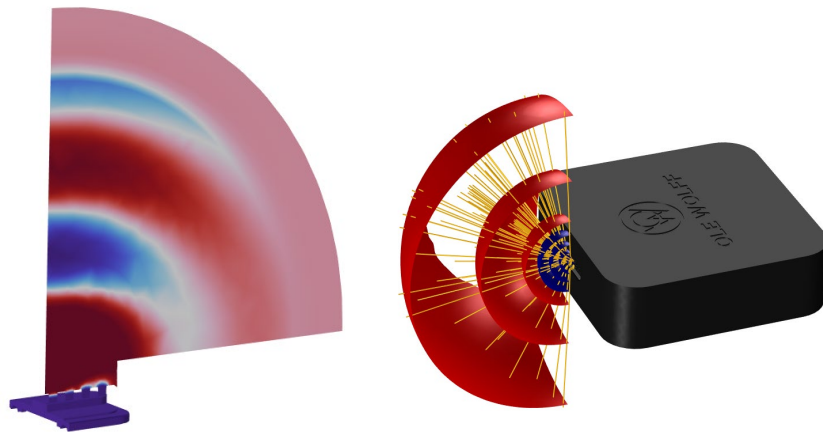

Good agreement between measurement and simulations.

Microspeaker application example 2

Bluetooth speakerbox with 2x passive radiators

- Lumped speaker
- PR modelled using Shell and Solid mechanics



Physical prototype

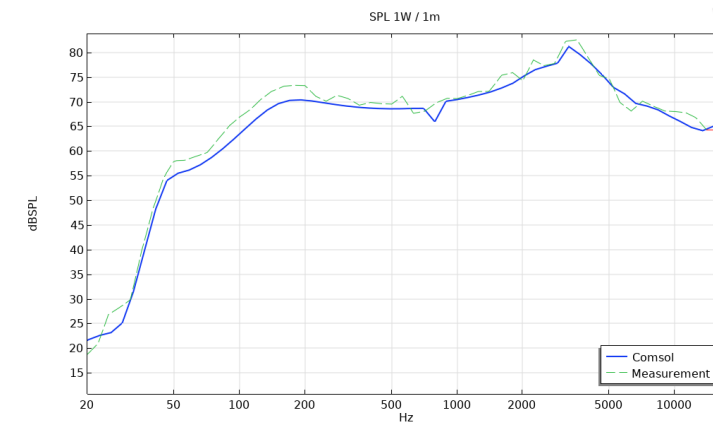
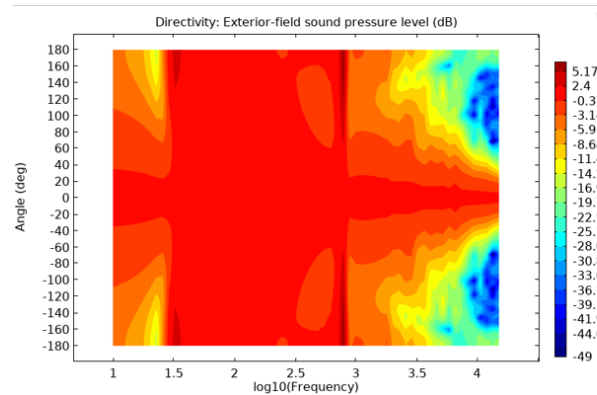
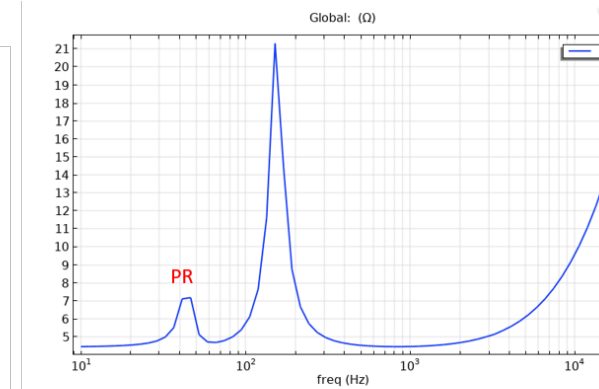
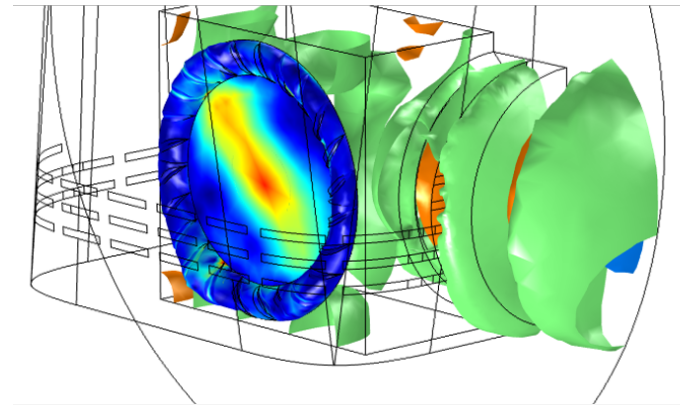

Microspeaker application example 3

Audio in “smart glasses”

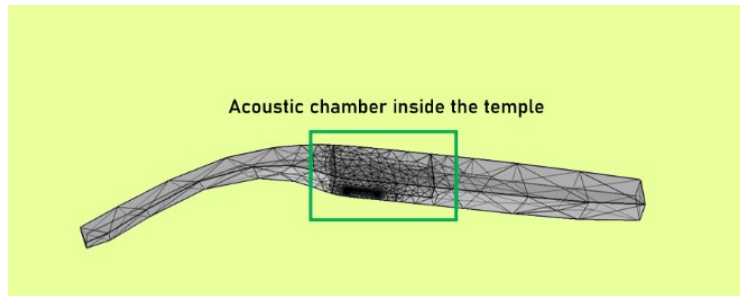

Name	Expression	Value
R_E	6.80[ohm]	6.8 Ω
L_e	0.033[mH]	3.3E-5 H
L2	0[mH]	0 H
R2	0[ohm]	0 Ω
M_MD	0.033[g]	3.3E-5 kg
R_MS	0.08[kg/s]	0.08 kg/s
C_MS	1.026[mm/N]	0.001026 s ² /kg
BL	0.494[T*m]	0.494 Wb/m
Fs	1/(2*pi*sqrt(C_MS...	859.03 1/s
M_MS	M_MD+2*S_D^2*...	3.3456E-5 kg
Q_ES	2*pi*Fs*M_MS*R_E...	5.0317
Q_MS	2*pi*Fs*M_MS/R...	2.2572
Q_TS	Q_MS*Q_ES/(Q_M...	1.5582
V_AS	rho0*c0^2*S_D^2...	4.2238E-7 m ³
S_D	0.54[cm^2]	5.4E-5 m ²

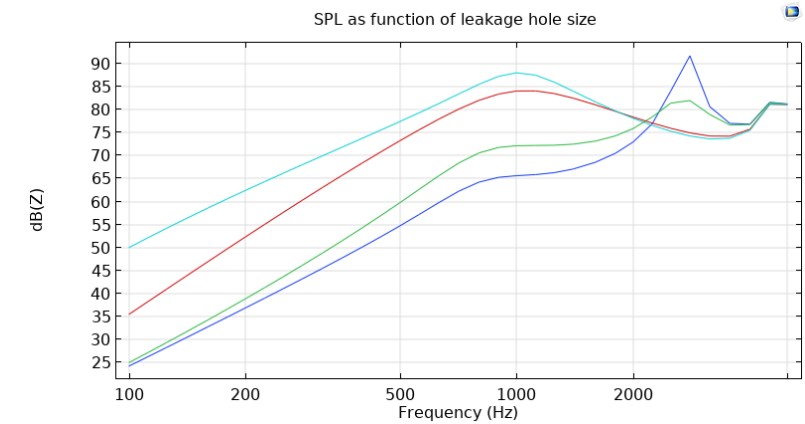
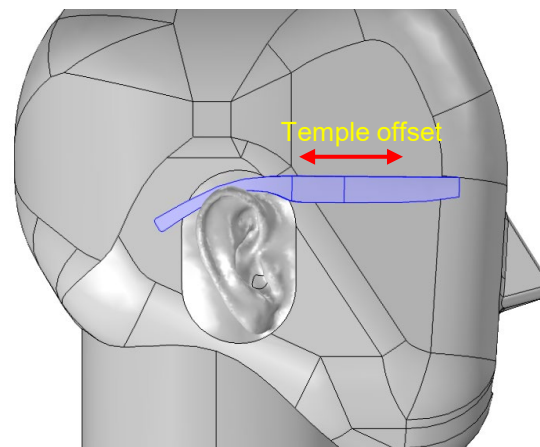
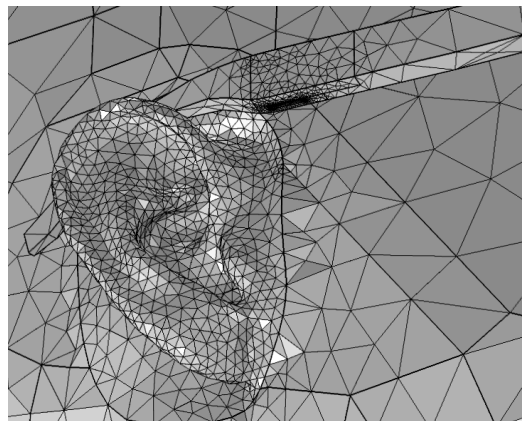
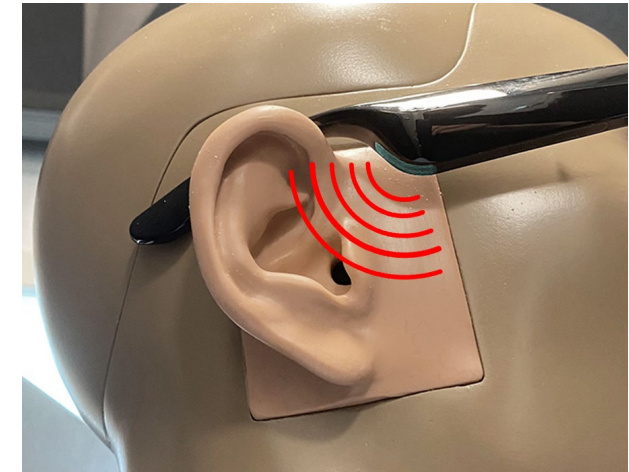

Earphone simulations

(1/3)

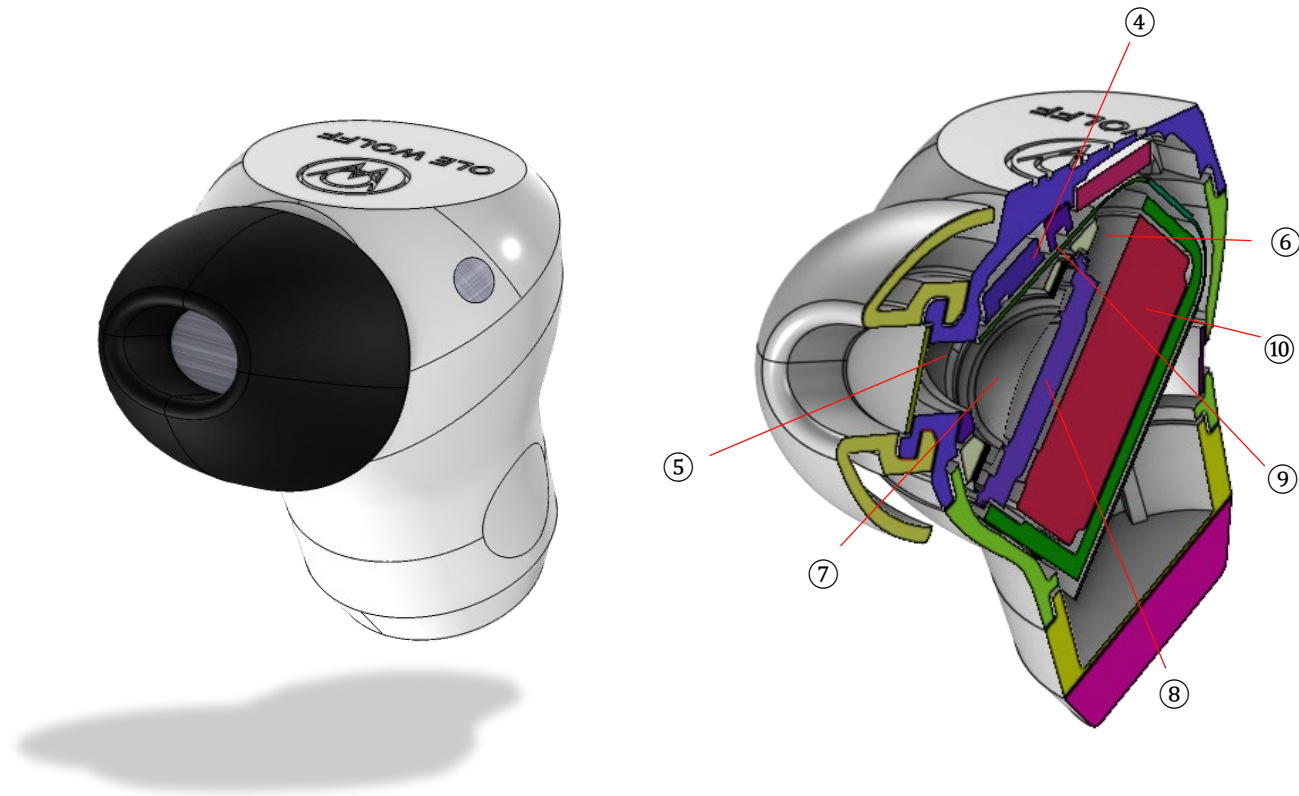

1. Nozzle mesh
2. Front leakage (for anti occlusion)
3. Rear leakage (for optimum bass response)
4. Feedback microphone for ANC (response modelled in Comsol)
5. Front volume
6. Rear volume
7. Ole Wolff earphone driver - modelled using TS parameters or using a full vibroacoustic model that includes diaphragm breakups etc.
8. Internal air volume in driver
9. Channel connecting front- and rear volume
10. Volume taken up by electronics, battery etc.

Earphone simulations

(2/3)

- Only air volumes are included in the model

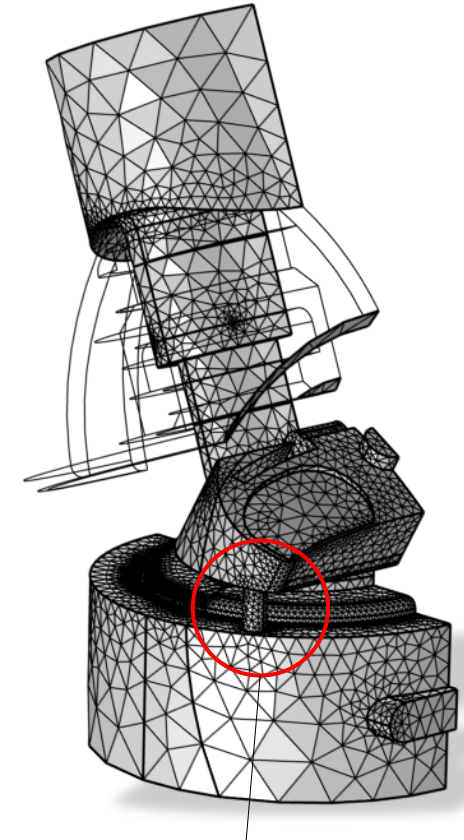
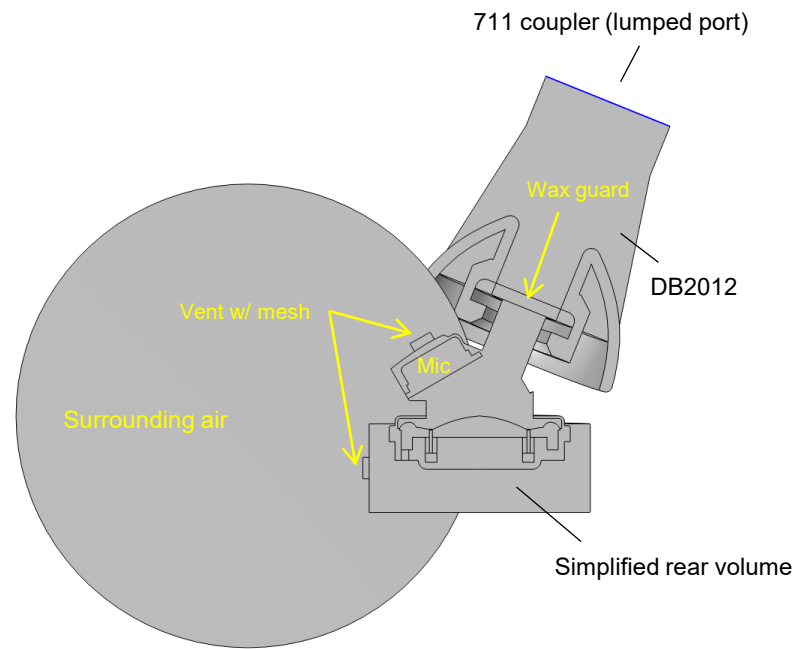

Tube connecting front vol. to rear vol.

Earphone simulations

(3/3)

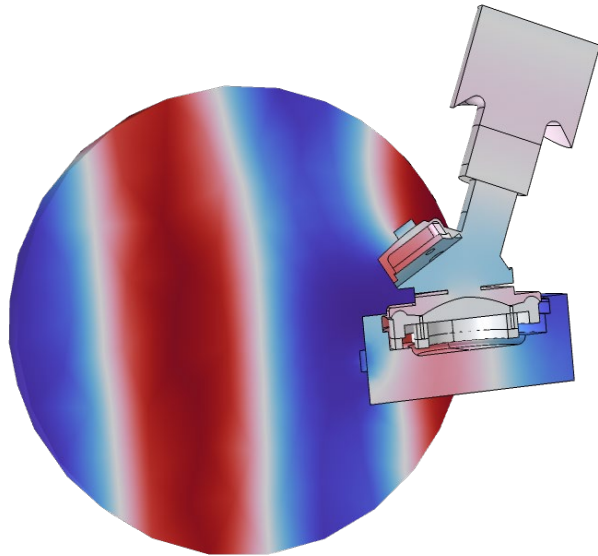

Background pressure (plane wave)

SPL, 711 coupler

126 mV

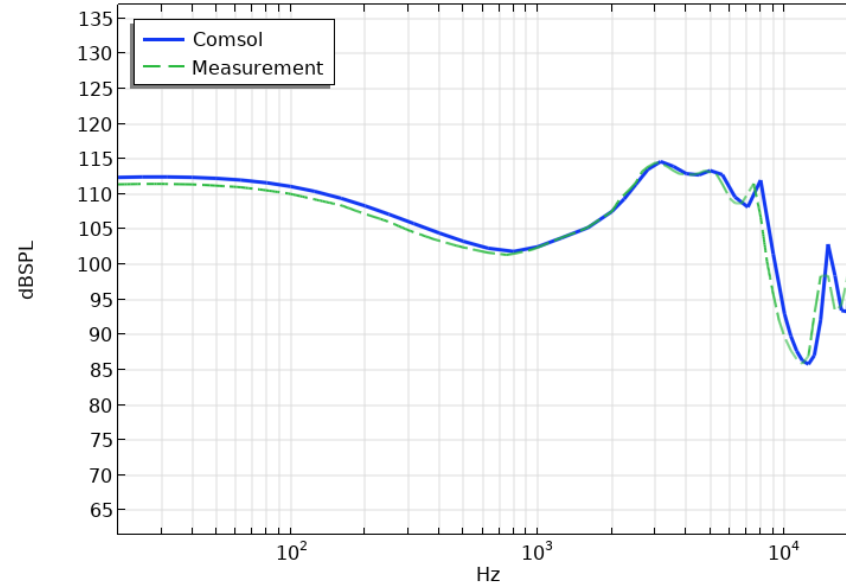

Passive attenuation

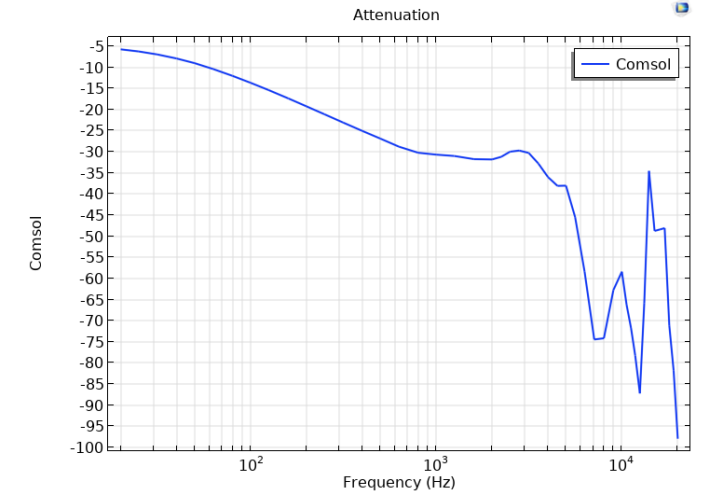

ANC feedback mic response

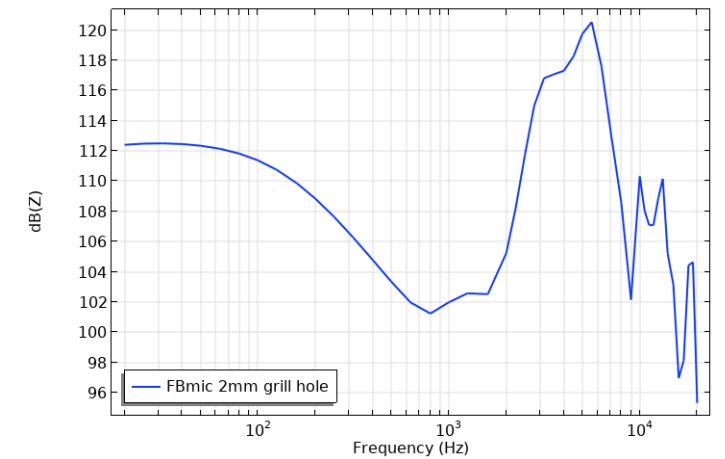

Headphone simulations

Traditional method

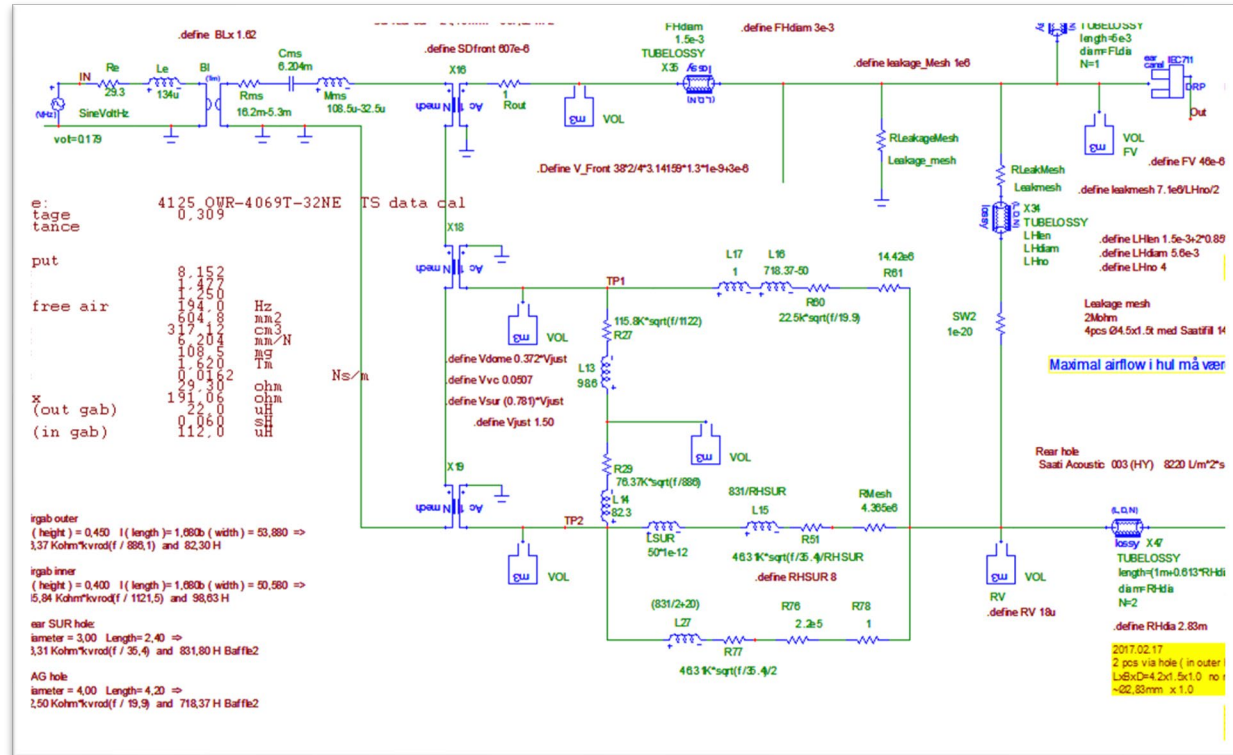

- Difficult to model complex geometries using lumped acoustic parameters
- Requires many physical prototypes



Headphone simulations

Using Comsol, (1/2)

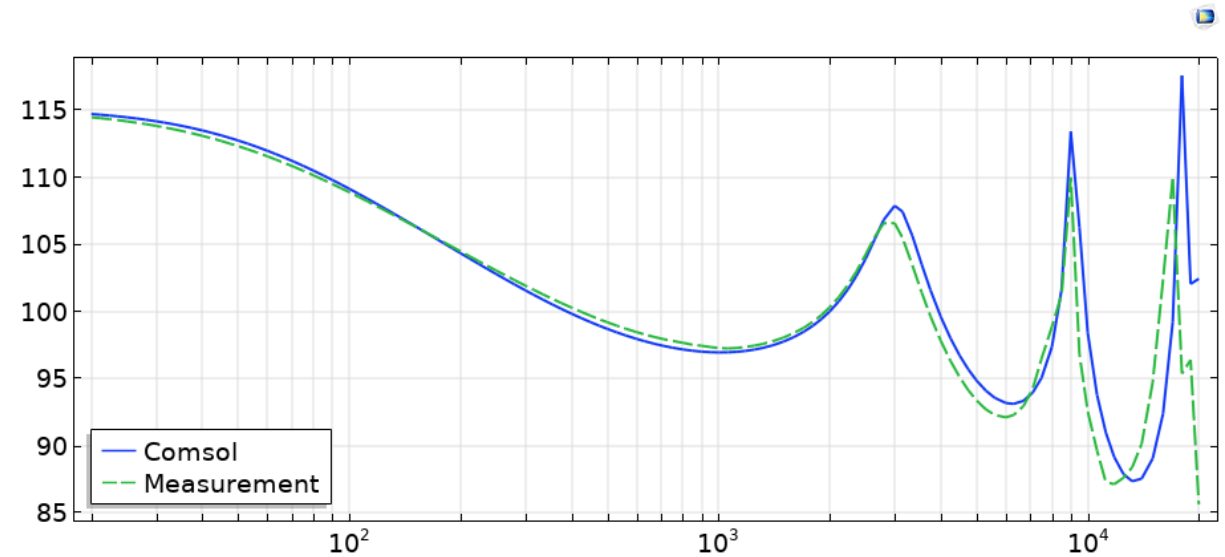
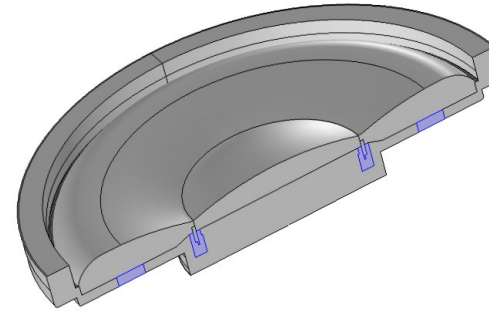
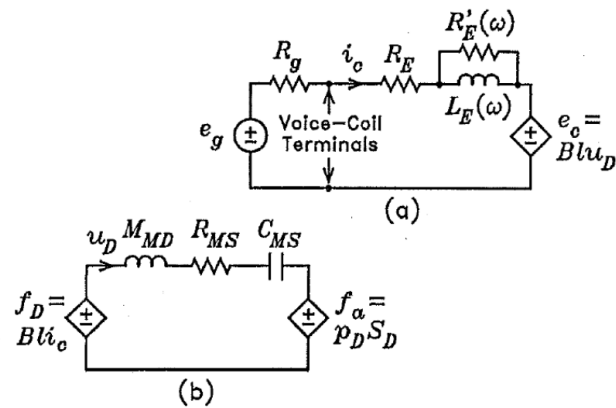

- Simple circuit model and geometry, easy to build into complex geometry

Headphone simulations

Using Comsol, 2 of 2

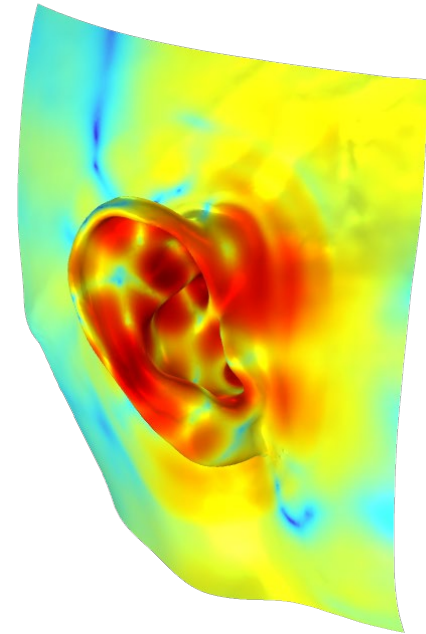

Sound pressure level on skin surface

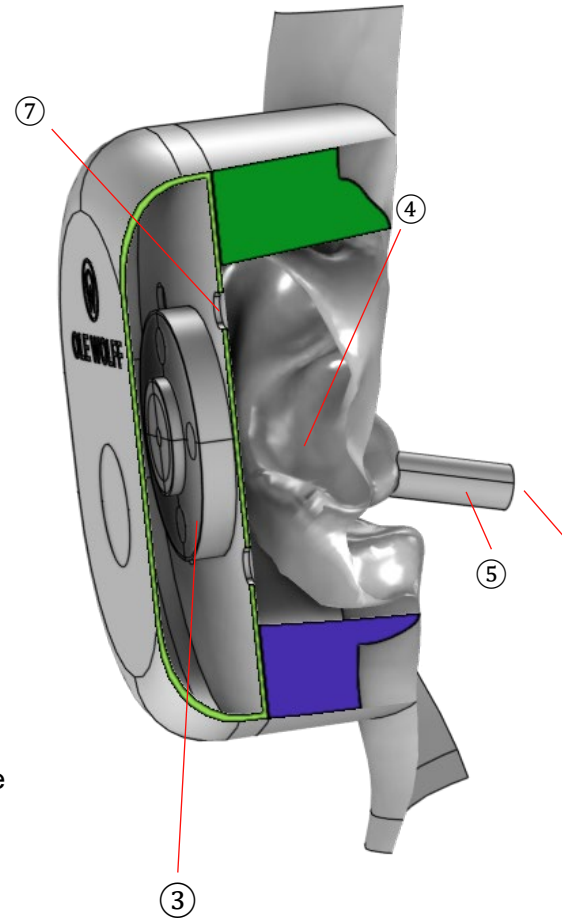

1. Rear mesh (if open back headphone). Closed-back headphones can also be modelled.
2. Cushion
3. Ole Wolff headphone driver - modelled using TS parameters or using a full vibroacoustic model that includes diaphragm breakups etc.
4. Ear with skin impedance
5. Ear canal
6. Eardrum impedance or 711 coupler model for verifying results in the lab.
7. Front-to-back leakage holes for bass tuning

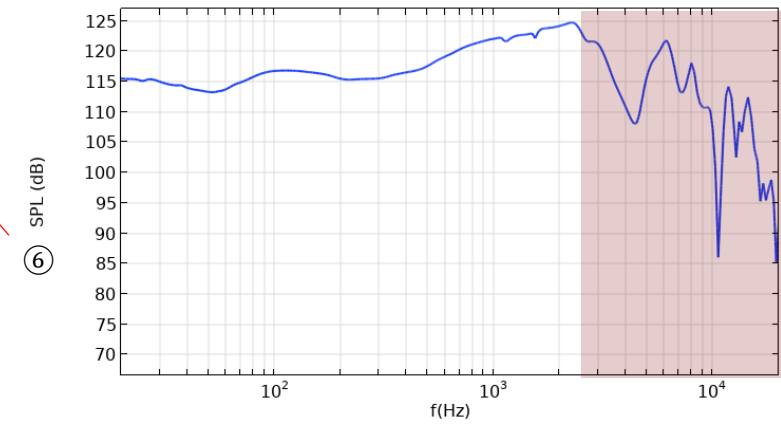

Good accuracy up to ~3 kHz

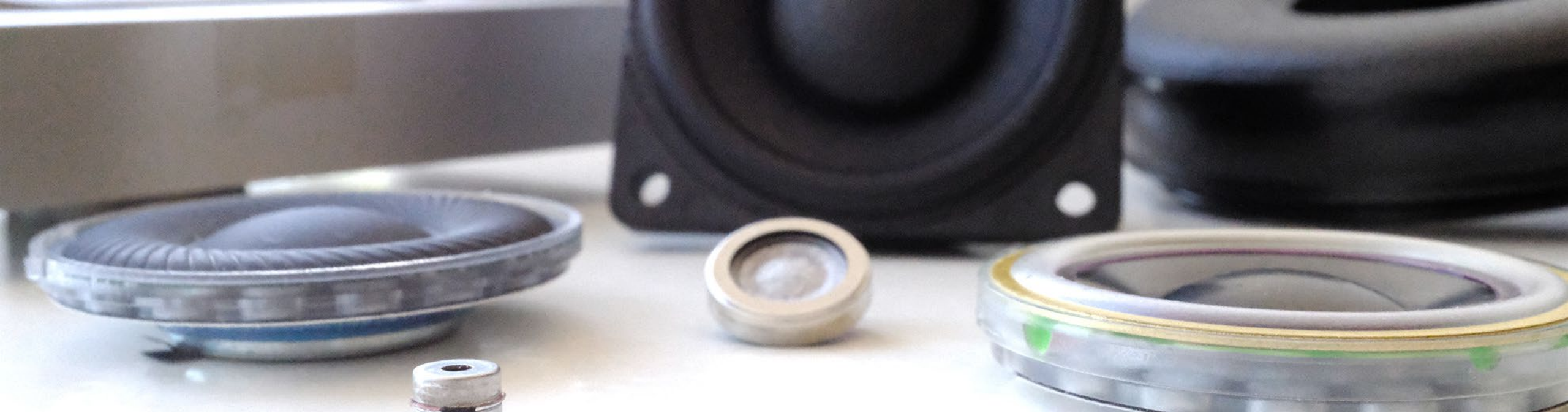

- **Thank you for listening!**
- **Questions**



pj@owolff.com
owolff.com