

DC-DC CONVERTERS

Maximizing Notebook Performance

Optimizing Notebooks with Effective DC-DC Converter Design

DC-DC converters are key to the overall performance of notebook computers. By efficiently stepping down the high voltage DC input (typically 19V or higher) from the external adapter to the lower voltages needed (usually 1V to 12V), they ensure smooth operation of the CPU, memory, graphics card, and other chipsets. These converters manage the power delivery system, balancing size, thermal management, and efficiency to provide longer battery life and improved system performance.

Block Diagram

For DC-DC converters to maintain optimal performance and efficiency, the following considerations should be incorporated into their design:

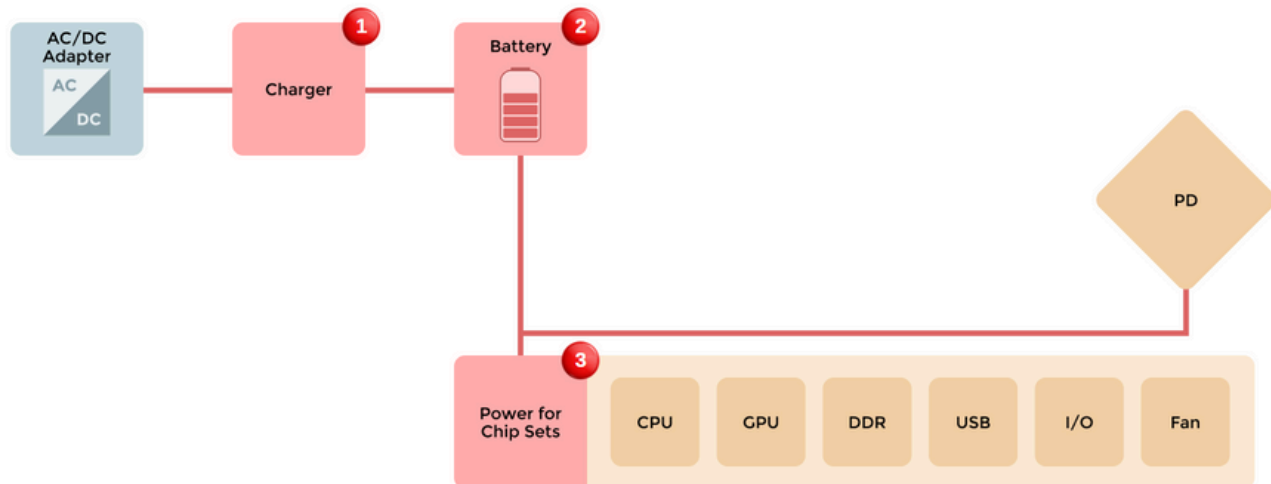

Recommended Products

Power MOSFETS



- ① MCACL280N03Y
- ① MCAC150N03A
- ① MCAC130N04
- ② MCAC100N03Y
- ② MCAC10H03A

Small Signal MOSFETS

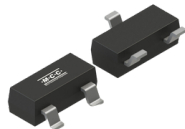

- ② SI2307
- ② SI0301
- ② SI3099
- ③ BSS138BKDW
- ③ SI3134KDWA
- ③ BSS8402DW

ESD Protection Devices

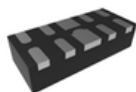

- ③ ESDULC0524P5
- ③ ESDULC0534P5

Key Design Considerations

- **Efficient and Compatible:** Optimal voltage regulation for all components.
- **Compact and Reliable:** Balances size, heat dissipation, and reliability.
- **Protected and Compliant:** Includes EMI/EMC compliance and advanced protection features.

TVS



- ① SM4F24CA
- ① SM4F22CA
- ② SM4F18CA
- ② SM4F22CA