



 snaptron

DESIGN GUIDE

snaptron.com
970.686.5682

ENGINEERING HANDBOOK FOR
METAL DOME SWITCH DESIGN

TABLE OF CONTENTS

INTRODUCTION	3-4
METAL DOMES	5-13
General Information	
Snaptron Part Numbers	
Dome Characteristics	
Force-Displacement Curve	
Dome Styles and Benefits	
Dome Options and Features	
Dome Plating	
DOME ARRAYS	14-17
Standard Peel-N-Place (PNP) Arrays	
Tolerances	
Custom Peel-N-Place (PNP) Arrays	
Adhesives	
General Information	
PLACING METAL DOMES	18-24
Placement Methods	
Soldering Methods	
Labor Cost Analysis	
Placing Dome Arrays	
Placement Technology	
Semi-Manual Placement	
Automated Placement	
PACKAGING	25-26
CIRCUIT DESIGN	27-28
Circuits and Plating	
Contamination	
Venting	
CONTACT PAD PATTERNS	29-32
SWITCH DESIGN	33
Actuators, Graphic Overlays, and Key Caps	
PERFORMANCE	34
DOME CARE	33
QUALITY AND TESTING	34-36
Quality Control and Compliance	
Force and Life	
TERMS AND DEFINITIONS	37-38

INTRODUCTION

BASICS OF METAL DOMES

For over 30 years, engineers and product designers sought out Snaptron's metal dome switches for their controlled, consistent feel, and reliability. This design guide will assist you with the design of metal tactile domes in your application. Each application is unique; therefore, we recommend you contact Snaptron to confirm the information contained in this design guide. We convey this information for customer support with the intent that you are responsible for the final design of your product.

WHAT ARE TACTILE DOMES?

Metal tactile domes are momentary switch contacts that become normally-open tactile switches when used with a printed circuit board (PCB), flex circuit, or other contact surfaces. Metal domes can also be used as a mechanical tactile element or even an constant force spring where a non-electrical function is required.

Tactile domes are typically placed onto a substrate (PCB or flex circuit) with pressure-sensitive adhesive tape or are captured in a spacer pocket design or product housing. In their relaxed state, the domes rest on the outer rim of the primary pathway. When pushed, the center of the dome trips or collapses, contacting the secondary pathway, thereby closing the circuit.

WHAT ARE THE ADVANTAGES OF TACTILE DOMES?

Metal domes are low-profile and provide a distinct tactile feel, making them ideal for various applications. Metal domes come in a wide range of sizes from 4mm to 50mm diameter and forces from 40g to 6,800g. They are a highly customizable switch solution. Snaptron can manufacture quick-turn custom domes or dome arrays to accommodate unique design or force requirements. You can add numerous distinct features to domes, including a hole for backlighting, force concentrators, dimples, over-travel capability, plating, and more.

WHAT INDUSTRIES USE TACTILE DOMES?

You will see metal domes used in numerous industries from medical to automotive, consumer electronics and more, including:

- › Automotive & Aviation
- › Communications
- › Discrete Switch
- › Military & Security
- › Membrane Switch
- › Medical
- › Appliance
- › Consumer Electronics
- › Computer/Peripheral
- › Instrumentation/Controls

WHAT PRODUCTS USE TACTILE DOMES?

Metal domes are used in many different products and applications including:

- › Medical equipment
- › Fitness wearables
- › Smart home products
- › Push-button control panels
- › Military communications
- › Weapons, laser sights, and optics
- › Aviation instrument panels
- › Automotive and marine controls
- › IoT, AR/VR products
- › Computer peripherals

SAMPLES

Snaptron offers samples of standard part numbers to assist in choosing the ideal dome for your application. We provide the widest variety of dome styles in the industry, each with a different tactile feel and actuation force. You can request a complete design kit, ideal for prototyping, or samples of specific domes by visiting our website.

HOW TO PURCHASE

Snaptron manufactures all metal domes and related products at a 42,000 square foot facility in Windsor, Colorado, USA. To ensure we provide the highest level of service and expertise, we do not use distributors. Instead, we ship directly to our customers worldwide. To request a quote, please visit www.snaptron.com or call +1 970-686-5682.

“Snaptron has been a critical supplier of ours for many years. We have been very pleased with the quality of Snaptron's products and they have proven to withstand the test of time. We are especially pleased with the wonderful customer service. They consistently provide excellent service and always deliver on-time. Snaptron is one of our top tier essential suppliers.”

-Suzi Porte, Vice President of Operations, Dyna Graphics

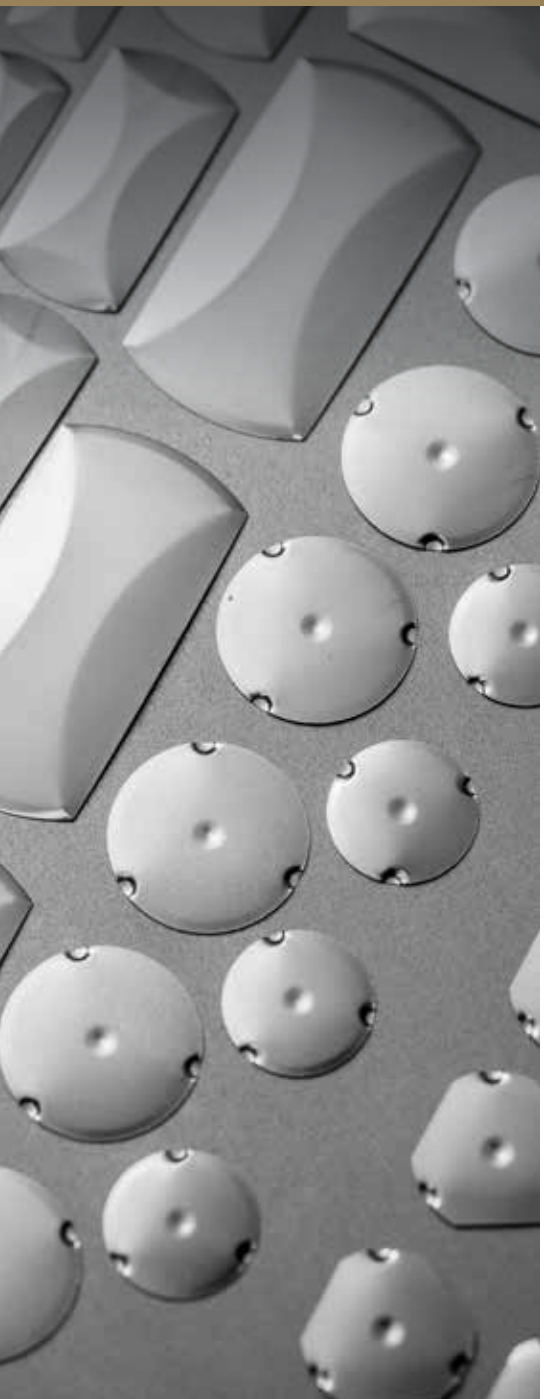

METAL DOMES

GENERAL INFORMATION

STANDARD DOMES

Snaptron carries a variety of standard domes in various shapes and sizes. Traditional styles include three-leg and four-leg, square, round, and oblong. Standard dome sizes range from 4mm to 37mm, with forces ranging from 40g to 6,800g. Most domes come standard in stainless steel or nickel plated, but other plating options are available.

CUSTOM DOMES

We understand that your product designs are unique. That's why Snaptron specializes in creating custom domes specifically designed to meet your specific needs. We can adjust actuation forces, tactile ratio levels, sizes, styles, and even add special features such as a center hole for backlighting, dimples, dual-action, non-tactile forces, etc.—with short lead times and minimal engineering charges. Depending on the complexity of the design, Snaptron can create new metal dome products within two to eight weeks.

ALTERNATIVE USES

Metal domes are typically normally-open switch contacts that provide a tactile feel and close a circuit when pressed (actuated) to a circuit pad. Tactile metal domes have a variety of non-traditional uses, including but not limited to—serving a mechanical or tactile purpose only (no electrical function); providing an audible response when “clicked”; functioning as a pressure switch; for use as a battery contact plate or spring.

SNAPTRON PART NUMBER EXAMPLE

Snaptron part numbers are deciphered the following way for example, FD12340N:

- › **F**.....Dome Series (F, U, GX, BL, TC, SQ, P, M, WT, RK, E, RCG, or DT)
- › **D**.....Dimple (No “D” indicates non-dimpled)
- › **12**.....Size (measured in either millimeters or inches)
- › **340**.....Actuation Force (measured in grams)
- › **N**.....Plating (N=Nickel, no letter indicates unplated stainless steel)
- › **C**.....Cartridge (C=Cartridge packaging, no letter indicates jars)

Note: Custom domes are assigned a part number beginning with “D1XXXXX”. Domes with gold plating are always custom. Not all part numbers come standard with nickel plating. Nickel plating may be custom. The above part number example indicates domes packaged in bulk (jars).

METAL DOMES

CHARACTERISTICS

THE RELATIONSHIP BETWEEN SIZE, FORCE, AND LIFE

When determining which dome is appropriate for your application, it is crucial to understand the relationship between dome size, trip force, and mechanical life. The size of a metal dome is the measurement of its diameter. The actuation force is the force needed for the dome to “snap” down and make contact with the circuit pad. Mechanical life refers to the number of mechanical cycles (actuators) the dome can withstand while maintaining adequate tactile characteristics.

As a general guideline, the larger a dome's diameter, the more trip force can be obtained while maintaining adequate mechanical life cycle specifications. For example, the F06180 (6mm, 180g force) is specified up to five million cycles, whereas the F06300 (6mm, 300g force) is only specified to 10,000 cycles. Factors such as dome style and shape can also contribute to a dome's mechanical performance. Snaptron's four-leg GX-Series and SQ-Series are wider in shape than Snaptron's standard four-leg F-Series, allowing them to achieve higher actuation forces without compromising life specifications. For example, a 6mm SQ-Series dome can achieve 400g force and up to ten million life cycles, whereas a 6mm F-Series dome can only reach 180g force with five million life specification. Snaptron's unique dome styles and attention to quality allow us to achieve the highest actuation forces and life specifications in the industry.

SIZE/DIAMETER

Snaptron diameters are measured in millimeters. In the part number description, the diameter is the first two numbers of a part number; for example, F12340 would indicate a 12mm diameter.

TRIP FORCE (Fmax)

Trip force (Fmax) is the amount of force necessary for the dome to “snap” down, changing the dome from an open position to a closed position. Typical actuation forces range from as little as 40 grams to over 2,000 grams. Snaptron always measures trip force in grams. In a typical part number description, the force is the last three numbers. For example, F12340 would indicate 340g force.

RELEASE FORCE (Fmin)

Minimum force seen between Fmax and the point at which the probe movement ceases. (Fmin) It is typically the force required to hold the dome in the closed (down) position.

TACTILE RATIO (Differential between Fmax and Fmin)

Trip and Release force numbers are used to calculate the Tactile Ratio percentage. The higher the tactile ratio, the more “snappy” a dome feels. (Tactile Ratio = 100 * (Trip – Release) / Trip). A tactile ratio of 100% would indicate a dome that requires no force to hold it in the closed (down) position. This is known as bi-stable. A tactile ratio of 0 indicates a dome that has a constant or increasing force from Fmax to contact.

HEIGHT

Height, or free height, is the measurement from the top of the dome to the surface it is resting on with no force applied. Dome height is measured after ten actuations in Snaptron's standard testing and inspection procedure.

METAL DOMES

CHARACTERISTICS

TRAVEL/DISPLACEMENT

Travel or displacement is defined as the height of a dome minus the material thickness (and dimple depth if present). All domes, except the M-Series, travel to level with the bottom of the legs or outer perimeter of the dome. M-Series domes can “over-travel” without damage. Over-travel means the dome’s center makes contact below the outer perimeter of a dome. Over-travel can damage a dome and cause the dome to become bi-stable, meaning it does not return to an open position and therefore has no tactile feedback.

LIFE (MECHANICAL)

Mechanical life refers to the number of actuations or cycles a dome can be expected to last before failing mechanically. The life ratings of domes will vary depending on their size, shape, and actuation force. Most Snaptron domes are rated up to five million cycles, and some domes, like the SQ-series, can reach ten million cycles. Other factors, such as plating, actuator design and alignment, the amount of force applied to a dome, and other product design factors can influence the life of a dome. Therefore, Snaptron recommends life cycle testing in your application before final production. All dome life specifications are available on our website.

THICKNESS

Thickness refers to the metal thickness of a dome and varies depending on the style, shape, and diameter. Standard Snaptron dome thickness ranges from 0.002” to 0.009”. Plating thickness may affect your end product’s characteristics.

DOMESTACKING

Stacking domes can increase trip force in your product without affecting the life of the domes. Snaptron suggests stacking four-leg domes with equal actuation forces and diameters from the same lot. In a pocket design, domes are captured with one dome placed directly over the other. Snaptron also offers Peel-N-Place arrays with F-series stacked domes. Domes can be rotated for easy Peel-N-Place assembly.

DIMPLE

Various Snaptron domes have a dimple located in the center of the dome. The addition of a dimple will accentuate and concentrate contact with the PCB and is often used for applications that need very accurate electrical contact or are prone to off-center actuations. Please note that domes with dimples may accelerate the wear of the circuit surface and may reduce travel and tactile feel. The designation for this feature is a “D” after the series. For example, in the part number, FD12340, D indicates a dimple.

TEASE

Tease, also known as switch tease, is an undesirable mechanical or electrical characteristic the user experiences when pushing a switch with the false presumption that a switch has been closed when actuated. When in fact, the switch requires extra force and travel to close the circuit. Tease is shown as the area between F_{min} and F_c on the diagram and is the distance between minimum force and electrical contact on the curve.

Note: The amount of switch sensitivity, or teasing, can also result from poor surface conductivity that will conduct an electrical event even when switch poles are in partial contact.

FORCE-DISPLACEMENT CURVE

When converted to a graphic curve (tactile slope), the force and displacement (travel) values can be used to distinguish the differences in tactile switch feel and performance. The diagram of a force-displacement curve (graph) was created by the ASTM F2592 standard (formerly the American Society for Testing and Materials). ASTM sets the standard for testing and measuring tactile switches via a tactile force-displacement curve. Force-displacement curves show a variety of force and displacement (travel) characteristics for tactile switches—including tactile response slope (forward actuation force/travel), tactile recovery slope (release force/travel), tactile ratio, and tease. The diagram shows force characteristics on the “Y” axis and displacement (travel) on the “X” axis. The top curve represents the forward travel of the switch to the contact point, while the lower curve shows the release (or return) force. The following are a definition of terms used in the diagram:

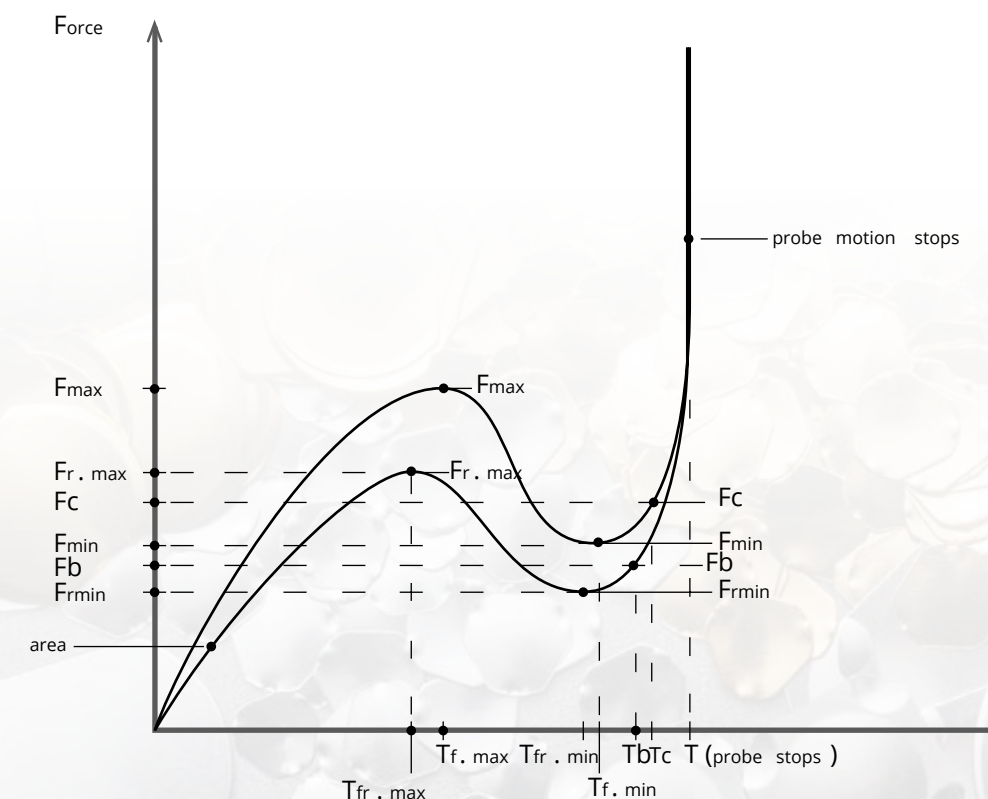

FORCE TERMS

- > F_{max} : Maximum force measured prior to or including F_{min}
- > F_{rmax} : Maximum force measured during return cycle after achieving F_{rmin}
- > F_{min} : Minimum force seen between F_{max} and the point at which the probe movement ceases
- > F_{rmin} : Minimum force seen during return cycle before reaching F_{rmax}
- > F_c : Contact force - the force at contact closure
- > F_b : Break force - the force at contact break

DISPLACEMENT (TRAVEL) TERMS

- > T_{fmax} : Displacement at F_{max}
- > T_{frmax} : Displacement at F_{rmax}
- > T_{fmin} : Displacement at F_{min}
- > T_{frmin} : Displacement at F_{rmin}
- > T_c : Contact displacement - the displacement at contact closure
- > T_b : Break displacement - the displacement at contact break

OTHER

- > Switch teasing (make): The displacement measurement on the force-displacement curve between contact force (F_c) and minimum force (F_{min})

METAL DOMES

STYLES AND BENEFITS

Typical dome styles include four-leg, three-leg, round, and oblong. Snaptron manufactures variations of these dome styles and custom domes upon request. Below is a complete guide to metal dome styles, their benefits, and naming conventions. Most of the below dome styles can support unique features such as dimples, concentrated force, over-travel, backlighting, plating, and more. Please consult with our team of experts to help you decide which dome style is suitable for your application.

METAL DOME STYLES

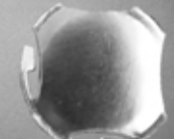





IMAGE	DOMES STYLES	SERIES	PRIMARY BENEFIT
	FOUR LEG	F-Series	Four-leg domes work with most applications, including single or double-sided circuit boards, flex circuits, or membrane switch panels. They can achieve high actuation forces, travel, and tactile feedback relative to their size.
	FOUR LEG WIDE	GX-Series	Four-leg, wide foot domes allow for high activation forces and long life, ideal for applications that require more force feedback.
	SQUARE	SQ-Series	Square domes can achieve actuations of up to 10 million cycles. They work with most applications, including single or double-sided circuit boards, flex circuits, or membrane switch panels.
	THREE LEG	DT-Series	Three-leg domes are like four-leg domes but have one short foot. These domes have two separate, progressive contact closures in a single dome switch.

IMAGE	DOMES STYLES	SERIES	PRIMARY BENEFIT
	SMD	S-Series	Solder domes are compatible with SMT equipment for use with high-speed production and component soldering.
	TRIANGLE	WT-Series	Triangle or three-leg domes can achieve high actuation forces despite their relatively small size. They are ideal for applications with limited or narrow available circuit board space.
	ROUND	P-Series	Round or circular domes are ideal for applications that require a low-profile switch with a soft tactile feel. Their round design makes them suitable for applications with a double-sided circuit board and a membrane overlay.
	OVAL	RK-Series	Oval-shaped domes resemble round domes with their soft tactile feel. They are ideal for applications with narrow spaces or where multiple domes or components must be placed close together.
	OBLONG	E-Series	Oblong domes have a 2:1 length versus width ratio. They are ideal for long narrow spaces or applications where a full hand squeeze is preferable to a single finger press. Oblong domes have a soft tactile feel.
	BATTERY CONTACTS	TB-Series, FB-Series	Low-profile battery terminal contacts are designed to be used as low profile battery contacts. Their low-profile makes them ideal for applications where space is limited. They can be configured in many sizes. This product is nickel plated for solderability and can be placed using traditional SMT equipment.



METAL DOMES

OPTIONS AND FEATURES

The chart below gives you a range of sizes, forces, tactile ratios, platings, and life cycles that Snaptron supports. If a standard dome does not meet your unique requirements, we can manufacture you a custom part. Please get in touch with us directly to determine any custom limitations.

METAL DOME OPTIONS

DOMES OPTIONS	RANGE	PRIMARY BENEFITS
DIAMETER	4mm to 50mm	Various sizes to meet PCB designs, space constraints, or unique uses. Custom diameters range from 37mm to 50mm.
TRIP FORCE	40g to 6800g	Force ranges directly correlate to the amount of force needed to activate the electrical connection.
TACTILE RATIO	Non-Tactile to 70%+	Provides the degree of tactile feedback synonymous with tactile domes, also described as how "snappy" a dome feels; non-tactile provides a linear spring without any tactile feedback.
PLATING	Non-plated, Nickel, Gold, or Silver	Plating options change or reduce contact resistance and can decrease board wear.
LIFE CYCLE RATINGS	10K to 10M	Life cycle ratings are typical and not guaranteed in every application.

AVAILABLE FEATURES

FEATURES	PRIMARY BENEFITS
CENTRAL HOLE	Provides the ability to incorporate an LED for backlighting or pass-through components.
REVERSE DIMPLE	Provides a concentrated actuation point or force concentrator to assist with size constraints and limits the impact from off-center actuation.
DIMPLE	Concentrates the contact point to the center of the dome.
MULTI-DIMPLE	Provides two or more contact points to assist with size constraints and limits the impact from off-center actuations.
FOOT DIMPLE	Maintains contact through two actuations (specifically for DT domes), provides a concentrated foot contact point for other dome styles.
RING	Helps reduce impact from debris, minimize wear at the center contact point, achieves two simultaneous circuit activations, and assists with off-center actuations.
HIGH TACTILE	Provides higher "snap" or stronger tactile feedback compared to other dome styles.
LOW TACTILE	Provides lower "snap" or weaker tactile feedback compared to other dome styles.
NON-TACTILE	Functions like a linear spring or contact force with no tactile feel.
OVER TRAVEL	For pushing the dome beyond a flat surface. Also used in instances when the user needs to press the dome beyond its flat surface, without damaging the switch.
HIGH TRAVEL	High travel provides a longer distance to the electrical contact, thus increasing the distance from initial press to full button press. This has the effect of increasing the tactile feedback of the dome.
LOW TRAVEL	Low travel provides a short distance to the electrical contact, thus reducing the distance from initial press to full button press.
BISTABLE	A dome that will hold itself in either the open or the closed position with no force applied. Often for one-time use applications that provide two conditions—a closed or open position or a tamper switch.

METAL DOME SPECIFICATIONS

These are general guidelines and represent the pre-assembly state. Specifications will vary depending on the substrate, circuit, and application. Contact Snaptron for individual product specifications.

- › Contact Configuration: SPST N.O. (Single Pole, Single Throw, Normally Open) Note: Except DT-Series (dual action)
- › Switching Voltage: 0.1 to 50 VDC
- › Switching Capacity: 1 Watt
- › Switching Current: 0.05 to 100 mA DC
- › Contact Bounce: <0.3ms make, <0.6ms break
- › Trip Force: 10% of trip force ≥ 400 grams typical
- › Height: +/- 0.003" (0.08mm) typical
- › Diameter: +/- 0.005"(0.13mm) typical
- › Material: Stainless steel
- › Plating: Nickel, Silver, and Gold optional
- › Operation Temperature Rating: -45° C to +100° C
- › Storage Temperature Rating: -55° C to +100° C
- › Mechanical Life: See individual part number specifications

Note: Various plating and plating thicknesses may affect product characteristics

METAL DOMES

PLATING

A variety of plating options are available depending on your specific application. Plating may vary depending on your requirements including life rating, contact resistance, and more. Custom plating options are available upon request.

NICKEL

Nickel flash plating is a low-cost alternative to gold plating and offers better contact resistance than unplated stainless steel. An “N” at the end of a part number (i.e., F12340N) indicates nickel plating. However, not all standard domes are available with nickel plating. Also, some domes are only available in nickel.

- › Plating specification: REF ASTM B689, Type1, 5-20 micro inches

GOLD

Gold plating offers the lowest contact resistance of any plating material, making it ideal for battery-operated devices. All gold-plated domes are not stocked and must be custom ordered. Gold flash plating is used and is on the contact side only unless otherwise specified by the customer.

- › Plating specification: REF MIL-DTL_45204D, Type 2, Grade C, Flash \geq 5 micro inches

SILVER

Silver offers the highest electrical conductivity but can oxidize or tarnish. However, the oxide layer is still highly conductive.

- › Plating Specification: REF ASTM B700, Type 2, Grade B, Class N, \geq 30 micro inches

CUSTOM

Custom plating options for material, thickness, one or two-sided plating and more are available upon request. Contact us today for all custom plating requests.

DOME ARRAYS

PEEL-N-PLACE ARRAYS

Snaptron offers standard (single dome on a pre-cut square of adhesive tape) and custom (multiple domes arranged to your specifications) Peel-N-Place (PNP) arrays. Pressure-sensitive adhesive tape is placed over the domes and attached to a non-stick carrier material. Domes are then peeled off the carrier, also known as a release liner, and placed onto your substrate, such as a PCB or flex circuit. Typical tape material thicknesses are 0.002” (0.05mm), 0.003” (0.08mm), 0.004” (0.10mm). PNP arrays are generally cut to match the shape of your substrate and can be placed visually, or Snaptron can manufacture custom placement fixtures to assist with the placement process. Custom Peel-N-Place arrays are designed to meet your requirements and reduce labor costs by placing multiple domes at once.

STANDARD PEEL-N-PLACE ARRAYS FOUR-LEG

PART NUMBER	Dome Diameter	Adhesive Size	Domes Per Sheet
PNP-05	5mm	9.53mm (0.375")	30
PNP-06	6mm	9.53mm (0.375")	30
PNP-07	7mm	9.53mm (0.375")	30
PNP-08	8.5mm	12.70mm (0.500")	30
PNP-10	10mm	14.27mm (0.562")	30
PNP-12	12mm	19.05mm (0.750")	20
PNP-14	14mm	21.59mm (0.850")	15
PNP-20	20mm	29.97mm (1.180")	6

ROUND

PART NUMBER	Dome Diameter	Adhesive Size	Domes Per Sheet
PNP-15	3.96mm (0.156")	8.03mm (0.316")	30
PNP-22	5.59mm (0.220")	9.53mm (0.375")	30
PNP-27	6.86mm (0.270")	9.53mm (0.375")	30
PNP-35	8.89mm (0.350")	12.70mm (0.500")	30
PNP-42	10.80mm (0.425")	19.05mm (0.750")	20
PNP-50	12.70mm (0.500")	19.05mm (0.750")	20
PNP-62	15.88mm (0.625")	21.59mm (0.850")	20

PEEL-N-PLACE TOLERANCES

Standard and custom dome array tolerances are as follows:

- › Dome position to Datum = +/- 0.015” (0.38mm)
- › Internal cut feature size = +/- 0.010” (0.25mm)
- › Perimeter cut size = +/- 0.010” (0.25mm)
- › Internal cut features and perimeter cut to Datum = +/- 0.010” (0.25mm)
- › Dome rotation = +/- 10 degrees

Note: Other tolerances may apply depending on the final design.

STANDARD PEEL-N-PLACE PART NUMBERS

Standard Peel-N-Place arrays (individual domes packaged on adhesive tape) are specified with a PNP-XX before the part number, whereas XX is the dome diameter. Example: PNP-12 (FD12340N) Visit our website for standard part number configurations.

BL-SERIES (BACKLIT)

PART NUMBER	Dome Diameter	Adhesive Size	Domes Per Sheet
PNP-08BL	8.5mm	12.70mm (0.500")	30
PNP-10BL	10mm	12.70mm (0.500")	30
PNP-12BL	12mm	19.05mm (0.750")	20
PNP-14BL	14mm	21.59mm (0.850")	15

DOMES ARRAYS

CUSTOM PEEL-N-PLACE ARRAYS

Custom Peel-N-Place arrays can be packaged in sheet form. Two F-Series domes can also be stacked to increase trip force. Compatible with the F-Series only. Custom Peel-N-Place arrays are indicated with a P1XXXXX, whereas XXXX is a number assigned by Snaptron.

CUSTOM PEEL-N-PLACE ARRAYS (DRAWINGS / ARTWORK)

The artwork of your design should include dome locations, dome orientations, the outer perimeter desired (i.e., edge of the board), and any internal cut features needed for board holes or “top side” components. Suggested formats are SolidWorks files, AutoCAD DWG, or DXF files. Additional formats may be acceptable. Contact Snaptron or visit our website for a complete range of compatible formats.

PROTOTYPES

Snaptron can manufacture quick-turn prototypes of Custom Peel-N-Place arrays. Typical lead times for low-volume prototypes are 7-14 days.

Note: Tolerances on prototypes may not match the final design.

ADHESIVE TAPE MATERIALS

PEEL-N-PLACE ARRAYS - STANDARD ADHESIVE TAPE MATERIALS

Adhesive is a common method to hold metal domes in place. Different adhesive tape (pressure sensitive) materials are available depending on your application needs and the size and style of the domes used.

PEEL-N-PLACE ARRAYS (STANDARD ADHESIVE SHEET SIZES)

Small – 5.3” x 4.5” (135mm x 114mm).

Array usable area – 3.8” x 3.0” (97mm x 76mm)

Medium – 8.0” x 7.0” (203mm x 178mm).

Array usable area – 6.5” x 5.5” (165mm x 140mm)

Custom – Available upon request.

TYPES OF STANDARD ADHESIVE TAPE MATERIALS

NAME	ADHESIVE LAYER	ADHESIVE LAYER THICKNESS	STRUCTURAL LAYER TYPE	STRUCTURAL LAYER THICKNESS	ADHESIVE SERVICE TEMPERATURE RANGE	TOTAL THICKNESS
3M 7993MP	Acrylic	0.002" (0.05mm)	Clear PET	0.001" (0.03mm)	-40 to 300 Deg F (-40 to 149 Deg C)	0.003" (0.08mm)
3M 7992MP	Acrylic	0.002" (0.05mm)	Clear PET	0.002" (0.05mm)	-40 to 300 Deg F (-40 to 149 Deg C)	0.004" (0.10mm)
Flexcon FLX059420	Acrylic	0.002" (0.05mm)	Clear PET	0.001" (0.03mm)	-40 to 302 Deg F (-40 to 150 Deg C)	0.003" (0.08mm)
Flexcon FLX000314	Acrylic	0.002" (0.05mm)	Clear PET	0.002" (0.05mm)	-40 to 302 Deg F (-40 to 150 Deg C)	0.004" (0.10mm)
Flexcon FLX000376	Acrylic	0.002" (0.05mm)	White PET	0.002" (0.05mm)	-40 to 302 Deg F (-40 to 150 Deg C)	0.004" (0.10mm)
Flexcon FLX002500	Acrylic	0.001" (0.03mm)	Clear PET	0.001" (0.03mm)	-40 to 257 Deg F (-40 to 125 Deg C)	0.002" (0.05mm)
Flexcon FLX002740	Acrylic	0.001" (0.03mm)	Clear PET	0.002" (0.05mm)	-40 to 257 Deg F (-40 to 125 Deg C)	0.003" (0.08mm)

CUSTOM ADHESIVE TAPE MATERIALS

Custom material quotes are available upon request. Snaptron offers polyimide tape (Kapton) for applications that may require extreme heat temperatures.

CUSTOM PEEL-N-PLACE ARRAYS WITH SPACER LAYER / DOUBLE OR MULTI-LAYER TAPE CONSTRUCTION

Metal domes packaged using a multi-layer tape construction provide a sealed environment while still allowing domes to vent when compressed. There are two different layers—the top layer and the venting layer. The top layer is the same as the single-layer tape construction described previously (Custom Peel-N-Place arrays). The venting layer has multiple options for material thickness. The general rule for choosing the proper thickness of the venting is; material thickness is equal to or less than half of the dome free height. Typical thicknesses used are 0.13mm (0.005”), 0.18mm (0.007”), 0.23mm (0.009”), 0.31mm (0.012”), 0.38mm (0.015”), 0.41mm (0.016”), and 0.48mm (0.019”).

Vent tracks or pathways are what allow air displacement from one dome cavity to another. The widths of these tracks are typically 0.100” (2.54mm). To maintain air seal, a minimum of 0.120” (3.05mm material is required from the venting feature (i.e. dome cavity or vent track) to the perimeter cut of the array or any through cut features (e.g., alignment holes). The multi layers are applied to each other using a mechanical laminator that has two pinch rollers. Once the layers are laminated, domes are loaded into the cavities.

CURE TIMES

Snaptron adhesive tapes have excellent bond strengths within the first 24 hours. Expect full cure time in 72 hours, or contact Snaptron for manufacturer specifications.



DOMES ARRAYS

GENERAL INFORMATION

PEEL-N-PLACE DOME SPACING

Domes must be spaced adequately to ensure proper adhesion. Domes placed too closely together can result in inadequate adhesion and excessive “bubbles” in the adhesive material. Proper spacing depends on the cover material, dome size, shape, height, and proximity of the dome to other objects. As a general guideline, Snaptron recommends a minimum of 3mm between dome locations and from any dome location to the end of the substrate.

AVOIDING CONTAMINATION / SEALING

Using adhesive tape (Peel-N-Place arrays) is one way to minimize contamination on the contact area of your substrate. In addition, adhesive tape, accompanied by proper venting and product design, can minimize unwanted contaminants.

AIR POCKETS

When securing a dome with pressure-sensitive adhesive tape, it is crucial to move air out of the venting area so that the domes don’t “float.” Floating is caused when the air pocket around the dome causes the dome to stick to the top of the tape so that it is not resting securely on the PCB or flexible circuit pad. To prevent this, first place the domes on the PCB. Next, make sure the adhesive around the edges of the dome is secured to the PCB, and then move outward to the adhesive edges.

Note: Be careful to prevent pre-load, which is when the adhesive is too tight around the dome, causing force to be applied to the dome.

PLACING METAL DOMES

PLACEMENT METHODS

Metal domes can be placed in a variety of ways. The following placement techniques are in order from the most manual to the most automated methods:



TWEEZERS

The most labor-intensive way to place domes is with tweezers. With this method, double dome placement is common.

VACUUM PEN

A vacuum pen is a common way to place metal domes. However, double doming is also a concern with this placement method.

DART™ DOME PLACEMENT PEN

The Dart Dome Placement Pen is a handheld, manually operated device that places one dome with each press of a button. Domes are pre-loaded in cartridges by Snaptron. The Dart dispenses one dome per press, preventing double domes. In addition, Snaptron can customize the nose head on the Dart to accommodate feet up or feet down dome orientations or to even align to your tooling or product housing.

APPLICATION FIXTURE

An application placement fixture is a custom manufactured tool used to place adhesive dome arrays on a circuit board. Application fixtures are affordable, more accurate than visual alignment, and make placing arrays quick and easy. Fixture design uses guide pins and the edges of the PCB for alignment during assembly. If your PCB design is more complex, the fixture can use existing holes in your PCB for proper alignment.

SURESHOT™ AUTOMATED PLACEMENT MACHINE

Snaptron designed the SureShot Automated Placement Machine to dispense domes automatically. Domes are pre-loaded into cartridges by Snaptron and placed in the patented Arrow Dispensing Head. The SureShot ensures that domes are set accurately and rapidly with no double domes. In addition, because domes are packaged in cartridges, the SureShot moves from position to position, placing domes at speeds of up to 10,000 domes per hour.

TAPE AND REEL

Snaptron offers tape and reel packaging for use with SMT or pick and place equipment. Most domes placed in tape and reel can be oriented with the feet up or down, except for SMD domes, also known as the S-Series. Two tabs on the SMD dome allow it to be soldered directly to the circuit board.

Note: We recommend that your mounting/circuit surface be clean before dome placement.

PLACING METAL DOMES

SOLDERING METHODS

Traditional methods of adhering metal domes to the circuit board require the use of adhesive tape or placement into spacer pockets. This process is typically done semi-automatically or manually and requires an assembler. SMD domes, also known as the S-Series, can be placed using automated equipment. These domes have two tabs that get soldered to the substrate. You can either manually or automatically solder the dome in place using SMT assembly systems.

SMT ASSEMBLY PROCESS

Snaptron recommends you follow the below steps to solder the dome to the substrate:

1. Solder paste and flux is applied to the PCB on the pre-determined solder pads either with a stencil or printing machine.
2. An SMT machine automatically places components including the dome on a PCB's appropriate locations.
3. The PCB, either fully or partially populated with components, is then passed through a reflow soldering oven with different heat zones. Many solder pastes require at least three heat zones. The first zone gradually increases the temperature of the board, components, and solder paste. The second zone brings the solder paste to its melting point to create the solder joint with the component. The last zone reduces the components' temperature and allows the solder paste time to solidify thus creating the solder joint.
4. If additional components need to be added, repeat this process. Snaptron recommends applying the domes in the last reflow process if there is more than one.
5. Before final assembly, the PCB is sent for quality inspection to ensure all components have adhered correctly or need to be reworked manually.
6. At this point and only if needed, a layer of cover tape can be added to seal the dome switches to keep out contaminants.

S-SERIES PROCESS

The S-Series domes have special considerations for the assembly process. Please consider the following:

1. Mechanical placement will involve a pressing force onto the dome. Please ensure the placement force is less than the rated actuation force of the dome.
2. Snaptron recommends using a 'No-Clean' Flux for dome soldering. Domes can have water spotting. Spot deposits could affect dome performance.
3. If desired, a cover tape layer can be added to seal the switches from components or for handling damages after solder reflow.
4. It is not recommended to use glue or other bonding methods to adhere the domes prior to soldering.

PLACING METAL DOMES

SOLDERING METHODS

SOLDER TYPES AND THERMAL PROFILES

Solder pastes contain an alloy of metals that, when heated and cooled, create a solder joint between two substrates, in this case, a PCB and metal dome switch. Depending on the type of solder paste, they also require different thermal profiles. Traditional reflow soldering is performed with either a leaded solder, lead-free solder, low temperature solder, or other, depending on the components being placed and product requirements. In addition, solder pastes vary in particle size. Therefore, it is important to select a solder that adequately adheres to a component while not requiring a temperature that may damage the component, another component, or the PCB.

DETERMINING SOLDER PASTE AMOUNT

You must understand the space constraints, the distance between components and the footprint of the metal dome to determine an appropriate amount of solder paste. In general, the recommended amount of paste for soldering a dome should be approximately 40% - 50% of the area of the solder pad. If too much solder paste is added, the solder may move into the solder keep-out area and either cause the dome to fail or prevent the dome from making electrical contact. On the other hand, if too little solder paste is added, the solder joint may not be strong enough to withstand the full range of presses and can cause an early switch failure.

To prevent an over application of solder paste resulting in an increased risk of solder wicking along the dome's solderable tabs, Snaptron recommends using a 5mil (0.13mm) thickness solder stencil with fresh solder paste on every paste application. We also recommend considering best flux outgassing practices to ensure contaminate flux deposits are removed during reflow. Please follow recommended procedures from the solder paste or flux manufacturer. Snaptron also recommends allowing at least 50mil separation between the dome and other SMT parts near the dome's solder tabs.

DOUBLE-SIDED SOLDERING

In many cases, components are placed on both sides of a PCB. This is performed by soldering one side and then the other in a two-step process. If placing the domes during the first soldering step, adhesive material like Kapton (polyimide) may be added after soldering to hold the domes in place during reflow of the other side. This material may fully cover the domes, but this is not required.

SEALING COMPONENTS POST-SOLDERING

For use cases in which you anticipate an abundance of contamination due to environmental exposure or board wear, it is important to know that the solder dome is not fully sealed. PET or polyimide can be added to create a fully sealed surface over the dome to keep out contaminants. However, there is no need for this adhesive material to be accurately positioned as would be the case when the domes are placed with the adhesive.





PLACING METAL DOMES

PLACEMENT TECHNOLOGY

LABOR COST ANALYSIS

Snaptron placement equipment can help you save time and labor costs. Below is an example of how improving your placement efficiency can streamline your processes and reduce labor costs.

DOMES PLACED	MANUAL	DART	SURESHOT
	AVERAGE TIME IN HOURS		
5,000	8.33	2.63	0.50
10,000	16.67	5.26	1.00
25,000	41.67	13.16	2.50
50,000	83.33	26.32	5.00
100,000	166.67	52.63	10.00
250,000	416.67	131.58	25.00
500,000	833.33	263.16	50.00
1,000,000	1666.67	526.32	100.00
3,000,000	5000.00	1578.95	300.00
5,000,000	8333.33	2631.58	500.00

Note: Domes loaded per hour is based on 50 positions and may vary based on specific applications.

TWEEZERS AND VACUUM PENS

Tweezers and vacuum pens are common, inexpensive ways to place domes and dome arrays. Due to the manual placement, both of these methods can lead to double doming and inaccurate placement. Extra care should be taken to ensure the domes are in the correct place and orientation.

POCKET DESIGN

To assist with accuracy of loose dome placement, we recommend adding a pocket design. A pocket design is a thin layer placed between an overlay and circuit that secures the dome and minimizes movement by creating a dedicated location for the dome. The height of the spacer layer should not exceed 50% of the total height of the dome and should not be less than 0.005" (0.13mm). Diameter should be 0.005" - 0.015" (0.13mm - 0.38mm) larger than the diameter of the dome depending on the tolerance required.

PLACING METAL DOMES

PLACING DOME ARRAYS

There are two methods for mounting Peel-N-Place arrays to your substrate. An assembler can manually place dome arrays using visual alignment or they can use an application fixture.

MANUAL PLACEMENT

To manually place a dome array, the assembler pulls the array off the backer and uses pressure from a finger to adhere and smooth the array to the substrate. This will often include a secondary operation for burnishing where consistent pressure is applied.

Note: We do not recommend applying concentrated pressure directly to the dome as this may cause cover material to "pre-load" the dome and affect the tactile feel.

APPLICATION FIXTURES (CUSTOM PEEL-N-PLACE ARRAYS)

Snaptron offers custom application fixtures for use with Custom Peel-N-Place arrays. Application fixtures ensure fast and accurate placement of the dome array to the application surface. Stand-off springs and alignment pins allow the assembler to press the PCB onto the PNP in one easy step. Custom fixtures for panelized circuit boards can be made as well. The fixture can provide accurate alignment using existing holes in the customer's PCB to accommodate more complex PCB designs.

A STEP-BY-STEP GUIDE TO APPLICATION FIXTURES

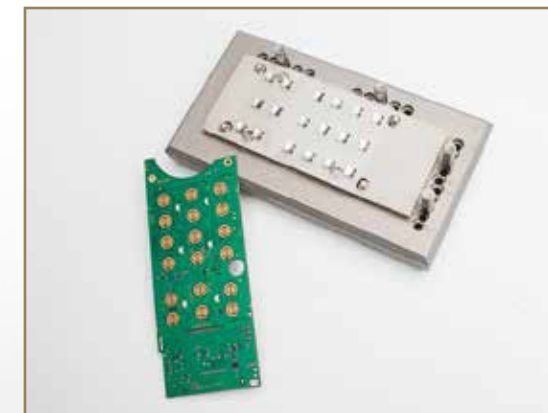

STEP ONE

Remove array from liner material and place on spring-loaded registration pins (adhesive side up).

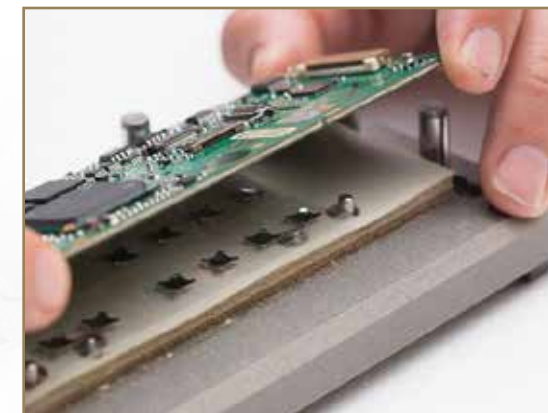

STEP TWO

Place board on spring-loaded standoffs and align board with edge guides.

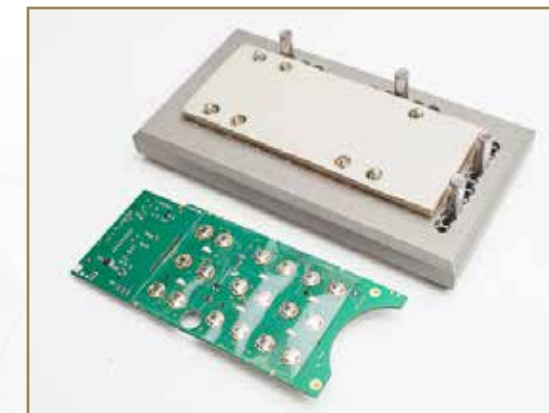

STEP THREE

Press board down onto the array to secure placement.

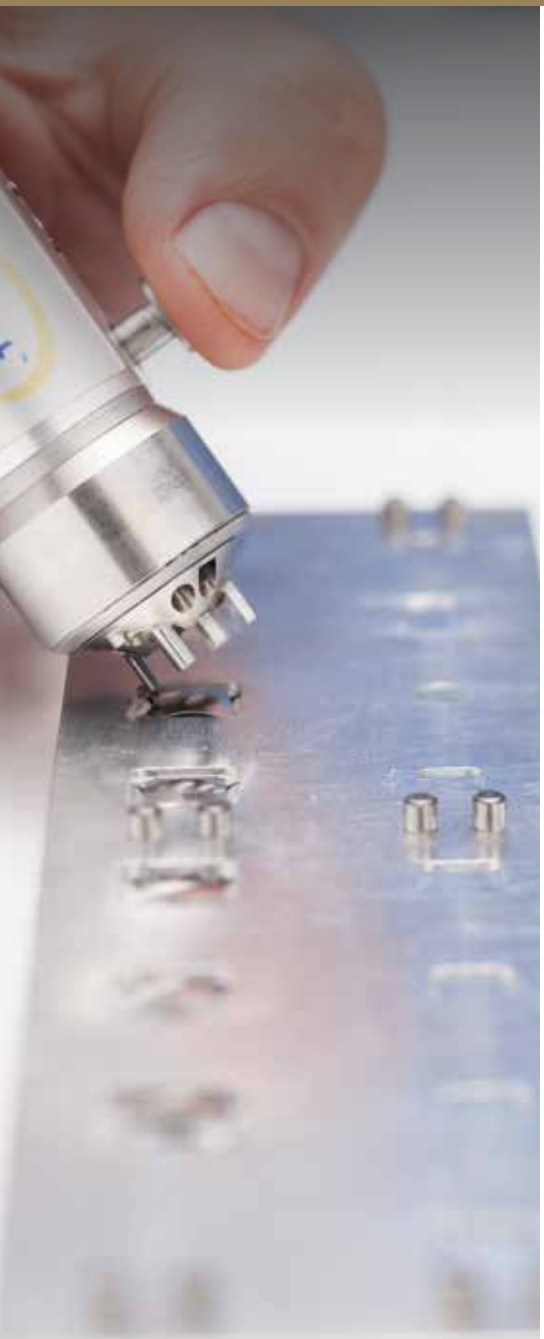

PLACING METAL DOMES

SEMI-MANUAL PLACEMENT

The Dart™ Dome Placement Pen is a patented handheld device for the manual placement of metal domes. Its patented design enables the user to point at the target, click a button, place a metal dome, and then move directly to the next target without reloading or picking up domes individually.

The Dart dispenses a single dome every time, eliminating quality errors associated with “double doming.” The result is a streamlined process of continuous dome placement, increased labor efficiency, and fast, accurate dome placement. The Dart can position metal domes into a product housing or on surfaces such as printed circuit boards, flex circuits, and membranes. It also allows you to dispense multiple domes on a single location if “stacking” is required.

Model numbers ending in U or D indicate whether the Dart can dispense domes feet up or feet down. Custom options are available. Model numbers will vary. Please check the cartridge label for dome orientation.

HOW IT WORKS

The Dart comes complete with a pen head, cartridge plunger, docking station, and user’s manual:

1. The Dart uses a cartridge pre-loaded with domes that attaches to the Dart pen head, which is spring-loaded to ensure proper dispensing.
2. To operate, the user simply points the head of the unit over the target area and presses the button to place the dome in the desired position.

Note: Preloaded cartridges sold separately.

The Dart is also available for lease. Visit our website for more information, terms, and pricing.

DART MODEL INFORMATION

MODEL	DISPENSES	CARTRIDGE SIZE	DOMES COUNT
D4140-525	14mm	7.5" x .558" (190.5mm x 14.2mm)	1,000
D4120-450	12mm	7.5" x .466" (190.5mm x 11.8mm)	1,250
D4100-365	10mm	7.5" x .413" (190.5mm x 10.5mm)	1,200
D4085-310	8.5mm	7.5" x .350" (190.5mm x 8.9mm)	1,500
D4070-260	7mm	7.5" x .318" (190.5mm x 8.1mm)	1,500
D4060-220	6mm	7.5" x .262" (190.5mm x 6.7mm)	1,500

PLACING METAL DOMES

AUTOMATED PLACEMENT

The SureShot™ is a high-speed automated system for the placement of metal domes. Its patented design dispenses Snaptron metal domes from a cartridge inserted into the Arrow™ placement head. The SureShot places a single dome on a target and then moves directly to the next target without reloading or moving to “home.” It can also be programmed to dispense predetermined multiples for stacking domes in specified positions. The SureShot is designed to place tactile metal domes on printed circuit boards, membranes, or flex circuits. Its compact tabletop design requires minimal space.

HOW IT WORKS

The SureShot comes complete with easy-to-use software, one Arrow Dispensing Head (6mm, 7mm, 8.5mm, 10mm, 12mm, 14mm, or 16mm) and user’s manual:

1. Dome placement coordinates are programmed and uploaded to the SureShot.
2. The operator chooses the project name from the built-in touch screen monitor to initiate the build.
3. The operator places the substrate onto the loading area.
4. After the loading is finished, the operator removes the completed work, inserts a new substrate, and continues production.

Note: Preloaded cartridges sold separately.

The SureShot is available in four model sizes. The SureShot 400 is also available for lease. Visit our website for more information, terms, and pricing.

SURESHOT MODEL INFORMATION

MODEL	SIZE	PLACEMENT RANGE
SureShot 300	28 x 28 x 15"	300 x 300mm
SureShot 400	32 x 32 x 22"	400 x 400mm
SureShot 500	36 x 36 x 22"	500 x 500mm
SureShot 650	41 x 46 x 22"	650 x 750mm



PACKAGING

ASSEMBLY PACKAGING OPTIONS

SNAPTRON DOMES

Snaptron domes can be packaged in a variety of ways depending on your specific needs.



BULK

Packaged loose in sealed plastic jars. Domes packaged in jars can range from the MOQ (minimum order quantity) to 50K per jar, depending on the size of the dome.

CARTRIDGES

Metal domes can be packaged in cartridges for use with the Dart Dome Placement Pen and the SureShot Automated Placement Machine.

TAPE AND REEL

Metal domes can be packaged in tape and reel format for use with traditional automated SMD placement equipment.

STANDARD PEEL-N-PLACE

Packaged on adhesive sheets which are 5.3" x 4.5". Metal domes are aligned in the center of a pre-cut adhesive square. The amount of domes per sheet is determined by the dome size (typically 20 or 30 domes/adhesive squares per sheet).

CUSTOM PEEL-N-PLACE ARRAYS (SHEET)

Each custom Peel-N-Place array is unique to the customer. Snaptron will recommend a sheet size, adhesive material, and quantity per sheet based on the drawing that you provide for your dome positions and layout.



PACKAGING

TAPE AND REEL

Metal domes can be packaged in tape and reel format for use with traditional automated SMT placement equipment. However, only Snaptron's SMD dome, also known as the S-Series can be soldered directly to the circuit and are only provided in the feet down orientation at a 45 degree angle.

TAPE AND REEL PACKAGING SPECIFICATIONS

SIZE	13" REEL	22" REEL
Dimensions	Ao 6.02mm, Bo 6.02mm and Ko 0.76mm	Ao 6.02mm, Bo 6.02mm and Ko 0.76mm
Type	Plastic	Plastic
Dome Quantity	5,000 per reel	15,000 per reel
Minimum Order Quantity	5,000	15,000
Order Quantities	Order quantities to be divisible by 5,000	Order quantities to be divisible by 15,000
Dome Orientation	Convex Up/Feet Down	Convex Up/Feet Down
Pocket Carrier	Pocket carrier to meet EIA-481 standard	Pocket carrier to meet EIA-481 standard
Carrier Width and Pitch	16mm with a pocket pitch of 12mm	16mm with a pocket pitch of 12mm
Cover Tape	Either clear PSA or Heat Bond	Either clear PSA or Heat Bond
Minimum leader	500mm	500mm
Reel Flange	330.20mm diameter with 101.60mm hub diameter	558.00mm diameter with 101.60mm hub diameter

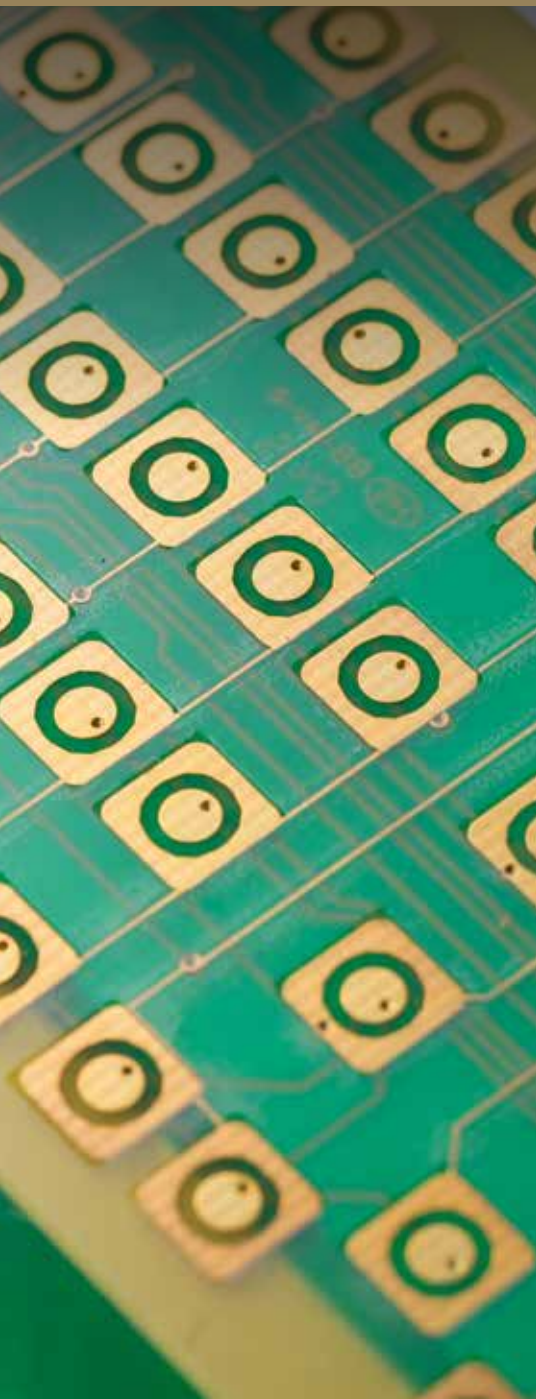

CIRCUIT DESIGN

CIRCUITS AND PLATING

COMMON CIRCUITS FOR DOME USE PRINTED CIRCUIT BOARDS (PCB)

Printed circuit boards are available in many thicknesses and serve as the bottom circuit for a metal dome contact.

FLEX CIRCUIT

A flex circuit is a pliable circuit that bends, usually made of polyester or polyimide. It must have support under the dome to prevent damage to the circuit and the dome.

MEMBRANE SWITCH

A membrane is a bottom circuit, a spacer pocket layer with metal domes, and a flat graphic overlay using screen print technology. A variety of overlay materials may be used when working with metal domes in

CIRCUIT BOARD PLATING

Proper plating is essential to prevent deterioration of the circuit pad over time. The first two plating options—hard nickel and hard gold—are recommended by Snaptron for optimal switch performance.

NICKEL

Electro-Deposited Nickel, Bright Hard (Ref – ASTM B689, Type I)

< 1,000,000 cycle life: 0.00005" – 0.0002" thick (50-200 micro inches or 1.27 – 5.0 micrometers)

> 1,000,000 cycles life: 0.0002" – 0.0005" thick (200-500 micro inches or 5.0 – 12.7 micrometers)

GOLD

Electro-Deposited Gold, Hard (Ref – MIL-DTL-45204D, Type II, Grade C)

< 1,000,000 cycles life: 0.000015" – 0.00003" thick (15 – 30 micro inches or 0.38 – 0.76 micrometer)

> 1,000,000 cycles life: 0.00003" – 0.00005" thick (30 – 50 micro inches or 0.76 – 1.27 micrometer)

ELECTROLESS NICKEL/IMMERSION GOLD (ENIG) (REF - IPC-4552)

ENIG plating can be a cost-effective option for appropriate applications. Metal dome contacts flex when actuated which can cause circuit pad wear over time. Therefore, ENIG is only recommended for applications with lower life cycle rates.

Note: Conductive inks, such as carbon ink, are a cost-effective solution for printed and flexible circuits. Snaptron does not have any recommendations on conductive inks. It is the responsibility of the customer to validate their application.

CIRCUIT DESIGN

CONTAMINATION AND VENTING

EXTERNAL AND INTERNAL CONTAMINATION

External and internal contamination can affect conductivity and the proper closure of a switch. Metal domes flex when actuated, which can cause circuit pad wear over time. Softer plating processes, such as ENIG and carbon inks, can contribute to circuit pad wear and internal contamination. Solder masks and films can also contribute to contamination and should not be present inside the circuit pad area. A switch or assembly should be adequately sealed to prevent external contamination issues, although proper venting must be considered.

- > Snaptron recommends life testing your specific application before production.
- > Recommendations for plating are based upon maintaining a stable electrical contact closure.

Note: Dome circuits must have sufficient support before making contact.

VENTING

The movement of air in and out from under the dome is called venting and it is important so that the dome functions properly. Air must be allowed to escape so that air pressure doesn't adversely affect the feel and function of the switch. There are two common methods for venting:

INTERNAL VENTING

Internal venting refers to allowing air to move either below or between domes. This method is commonly used in membrane applications or sealed applications.

Examples of internal venting are as follows:

- > A via hole in the PCB dome pad (bottom venting)
- > Placing narrow channels in the spacer pocket layer to allow air to pass back and forth between dome locations

EXTERNAL VENTING

External venting refers to venting over the top of the dome. A typical example would be cuts placed in the adhesive tape that allows air to escape. It should be noted that external venting may increase the risk of contamination.

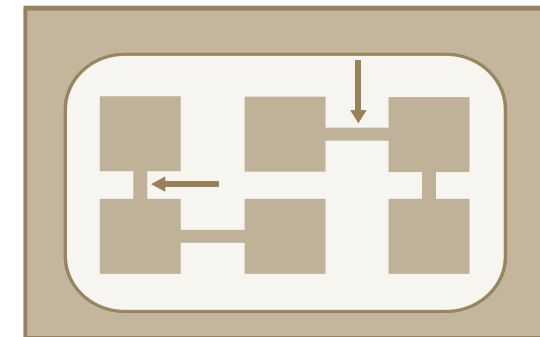
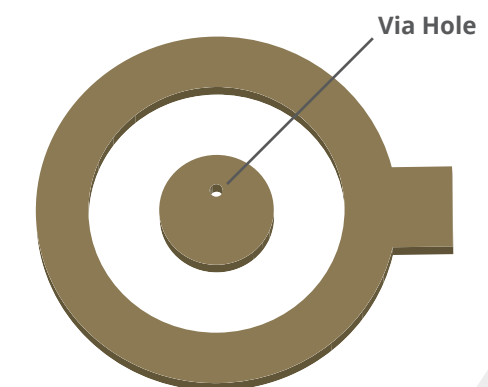

Air Channels



External Venting Example

CONTACT PAD PATTERNS

PCB PADS

SINGLE-SIDED

Suitable for F-, GX-, RCG-, SQ – TC- and U- Series domes

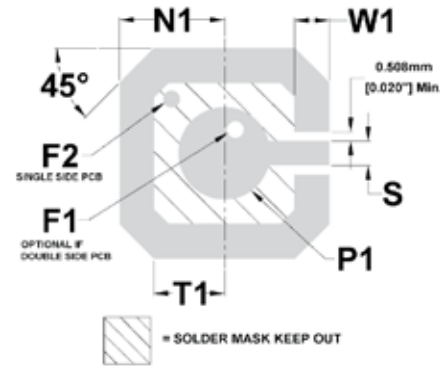

F = plated through hole positioned off-center

DIAMETER	P1	N1	T1	W1	S	F1 / F2
4mm	1.60	2.10	1.25	0.97	0.30	0.32
5mm/5.3mm	2.03	2.59	1.67	1.04	0.38	0.41
6mm/6.3mm	2.45	2.96	1.96	1.09	0.64	0.41
7mm	2.86	3.45	2.28	1.27	0.76	0.60
8.5mm	3.48	4.19	2.77	1.55	0.92	0.89
10mm	4.08	4.67	3.15	1.55	1.10	0.89
11mm	4.50	5.23	3.45	1.70	1.20	0.89
12mm	4.90	5.59	3.76	1.85	1.30	0.89
12.2mm	4.90	5.72	3.86	1.85	1.30	0.89
14mm	5.70	6.40	4.34	1.98	1.60	0.89
16mm	6.50	7.32	4.98	2.26	1.60	0.89
18mm	7.00	8.32	5.61	2.54	1.90	0.89
20.2mm	7.00	9.04	6.17	2.54	1.90	1.10
25.2mm	8.90	11.35	7.75	3.17	2.54	1.10
37mm	12.90	16.75	11.40	4.70	3.55	1.50

DOUBLE-SIDED

Suitable for all dome styles except oblong.

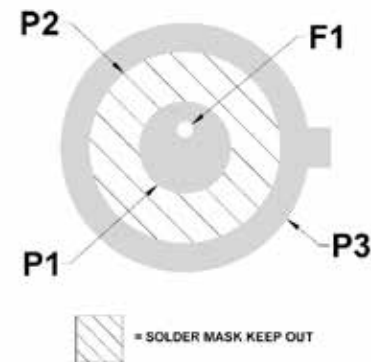

F = plated through hole positioned off-center

DIAMETER	P1	P2	P3	F1
4mm	1.70	2.71	4.76	0.32
5mm/5.3mm	2.03	4.00	5.76	0.41
6mm/6.3mm	2.54	5.00	6.76	0.41
7mm	2.86	5.45	8.25	0.60
8mm	3.20	6.73	9.27	0.60
8.5mm	3.81	6.98	9.78	0.89
9mm	3.81	7.48	10.27	0.89
10mm	4.08	8.49	11.28	0.89
11mm	4.50	9.34	12.28	0.89
12mm	4.90	10.18	13.27	0.89
12.2mm	4.90	10.38	13.47	0.89
12.7mm	4.90	10.83	13.97	0.89
14.1mm	5.70	12.06	15.27	0.89
16mm	6.50	14.25	17.27	0.89
20.2mm	7.00	18.09	21.90	0.89
25.2mm	8.90	21.55	26.98	1.10
37mm	12.90	30.50	39.37	1.50

SINGLE-SIDED THREE-LEG

Suitable for WT- and E-TDF Series

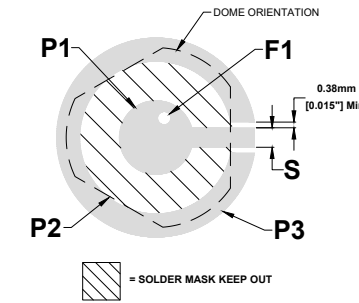

F = plated through hole positioned off-center

DIAMETER	P1	P2	P3	S	F1
4mm	1.70	3.00	4.76	0.25	0.32
5mm	2.03	4.00	5.76	0.38	0.41
6mm	2.54	5.00	6.76	0.64	0.41
7mm	2.86	5.45	8.25	0.76	0.60
8mm	3.20	6.73	9.27	0.90	0.89
9mm	3.81	7.48	10.27	1.00	0.89
10mm	4.08	8.49	11.28	1.10	0.89
12mm	4.90	10.18	13.27	1.30	0.89

Circuit pattern shown is keep-out area for any solder masks and films

These drawings represent one of many possible layouts. Snaptron convey this information for our customer support with the intent that customers are responsible for the final design of the PCB layout.

SINGLE-SIDED WITH LED

Suitable for BL-Series domes

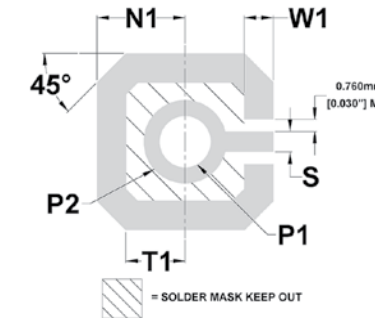

DIAMETER	P1	P2	N1	T1	W1	S
8.5mm	< dome hole diameter	4.25	4.19	2.77	1.09	0.92
10mm	< dome hole diameter	4.50	4.67	3.15	1.55	1.10
12mm	< dome hole diameter	5.25	5.59	3.76	1.85	1.30
14mm	< dome hole diameter	6.25	6.40	4.34	1.98	1.60

DOUBLE-SIDED WITH LED

Suitable for BL-Series domes

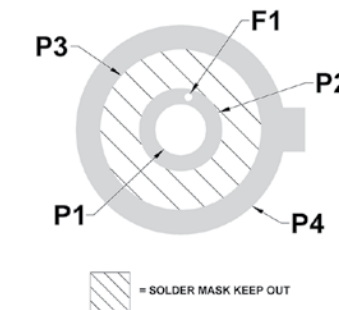

DIAMETER	P1	P2	P3	P4	F1
8.5mm	< dome hole diameter	4.25	6.98	9.78	0.38
10mm	< dome hole diameter	4.50	8.49	11.28	0.51
12mm	< dome hole diameter	5.25	10.18	13.27	0.51
14mm	< dome hole diameter	6.25	12.06	15.27	0.51

F = plated through hole positioned off-center

Note: Specifications and dimensions are subject to change. Please visit www.snaptron.com for latest information.

CONTACT PAD PATTERNS

PCB PADS

SINGLE AND DOUBLE-SIDED DT

Suitable for DT-Series domes

DIAMETER	P1	N1	N2	T1	T2	W1	W2	F1 / F2
6mm	2.45	2.96	2.68	1.96	0.96	1.09	2.86	0.41
7mm	2.86	3.45	3.09	2.28	1.12	1.27	3.09	0.60
8.5mm	3.48	4.19	3.77	2.77	1.35	1.55	3.84	0.61
10mm	4.08	4.67	4.34	3.15	1.73	1.55	4.62	0.89
12mm	4.90	5.59	5.20	3.76	2.07	1.85	5.31	0.89

F = plated through hole positioned off-center

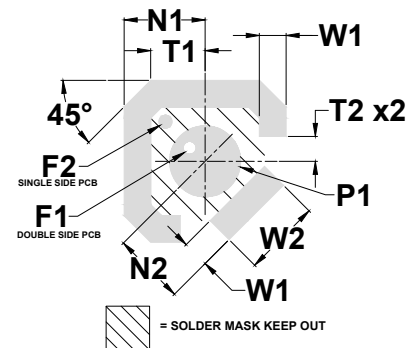

SINGLE AND DOUBLE-SIDED DT WITH LED

Suitable for DTBL domes

DIAMETER	P1	P2	N1	N2	T1	T2	W1	W2	F1
12mm	< dome hole diameter	5.25	5.59	5.20	3.76	1.72	1.85	5.31	0.51

F = plated through hole positioned off-center

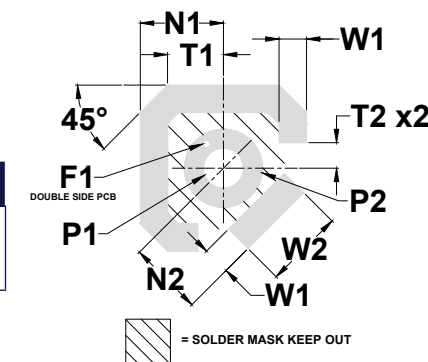

SINGLE-SIDED SOLDER DOME

Suitable for S-Series (SMD) domes

DIAMETER	P1	P2	P3	W1	N1	N2	N3	F1	SP
6.3mm	2.45	4.91	6.82	2.08	2.46	1.65	2.35	0.41	0.64

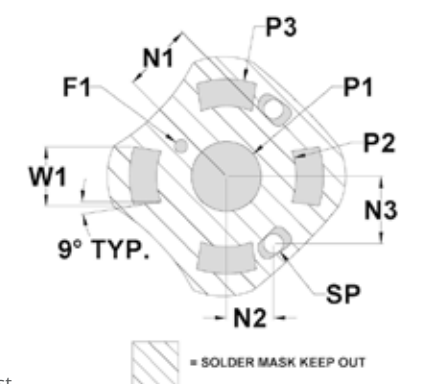

DOUBLE-SIDED OBLONG

Suitable for RK-Series and E-Series domes oblong (ONN) domes

1" AND SMALLER OBLONG

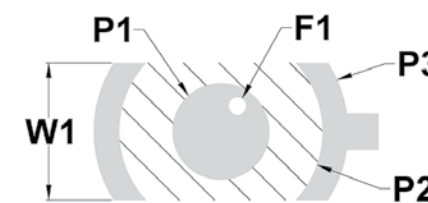

2" OBLONG

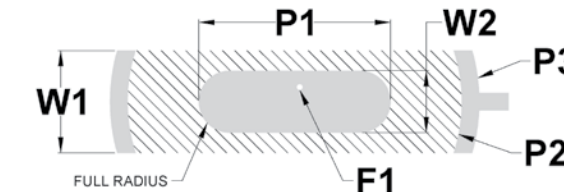

SERIES	DIAMETER	P1	P2	P3	W1	W2	F1
RK-Series	5.59	2.54	4.83	6.60	4.57	n/a	0.61
RK-Series	8.89	3.81	7.62	10.16	8.13	n/a	0.89
RK-Series	12.70	5.08	11.43	13.97	10.92	n/a	0.89
E-Series	11.18	4.83	10.16	12.70	6.86	n/a	0.89
E-Series	17.78	6.86	16.51	19.05	10.16	n/a	0.89
E-Series	25.40	8.89	24.13	26.67	13.97	n/a	0.89
E-Series (2")	50.80	27.69	48.26	53.34	14.73	8.89	0.89

F = plated through hole positioned off-center

SINGLE AND DOUBLE SIDED FOUR-LEG BATTERY CONTACTS

Suitable for FB-Series domes

SINGLE SIDED

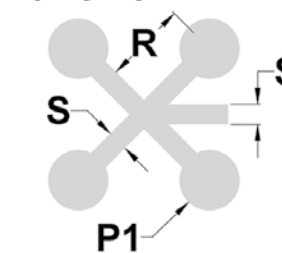

DOUBLE SIDED

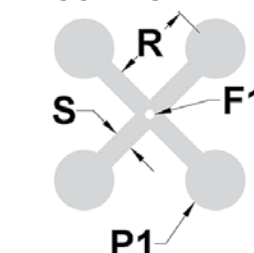

DIAMETER	P1	R	S	F1
6mm	2.15	2.69	0.89	0.38
7mm	2.15	3.15	0.89	0.38
12mm	3.81	5.28	1.27	0.64

F = plated through hole positioned off-center

SINGLE AND DOUBLE SIDED THREE-LEG BATTERY CONTACTS

Suitable for TB-Series domes

SINGLE SIDED

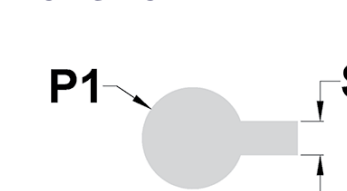

DOUBLE SIDED



DIAMETER	P1	S	F1
12mm	3.81	1.27	0.64

Circuit pattern shown is keep-out area for any solder masks and films

These drawings represent one of many possible layouts. Snaptron convey this information for our customer support with the intent that customers are responsible for the final design of the PCB layout.

Note: Specifications and dimensions are subject to change. Please visit www.snaptron.com for latest



SWITCH DESIGN

ACTUATORS, OVERLAYS, AND KEY CAPS

An actuator is a mechanical component of a switch assembly that contacts the dome to press it down to the closed position. Actuators often enhance the feel of a switch assembly by focusing force to the middle of the dome. A proper actuator is essential to receive the best tactile feel from your assembly and minimize damage to the dome. An actuator that is too large can damage the dome, reduce life, or cause it to go bistable.

Recommended Actuators

Snaptron recommends a flat-bottom plunger to actuate domes. The plunger should be no more than 25% of the dome's diameter. Actuators should always be placed at the center of the dome. In cases where a rocking or wiping actuator is used, we recommend a radius tip. Examples of different actuator (force concentrator) materials are ABS plastic, rubber/silicon (40 to 80 durometer), metals, and urethanes.

BL-SERIES ACTUATOR (FOR USE WITH CENTER HOLE FOR LED BACKLIGHTING)

DOMES HOLE	INSIDE EDGE (I.D.)	OUTSIDE EDGE (O.D.)
0.070" (1.78mm)	0.080" (2.03mm)	0.124" (3.15mm)
0.100" (2.54mm)	0.110" (2.80mm)	0.145" (3.68mm)
0.125" (3.18mm)	0.135" (3.43mm)	0.175" (4.45mm)
0.155" (3.94mm)	0.165" (4.19mm)	0.215" (5.46mm)

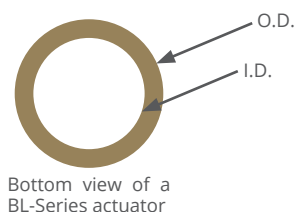

OVERLAY GRAPHICS / KEY CAPS

Actuators are built into each individual key. Multiple domes can be secured to the PCB using custom Peel-N-Place arrays (domes on pressure-sensitive adhesive tape).

Domes are placed in spacer pockets on the PCB and captured once the graphic overlay is secured. Snaptron works with various full-service providers of custom keypads, membrane switch panels, circuit pads, and flex circuits. We would be glad to provide referrals if needed.



PERFORMANCE

SAPPHIRE FORCE TEST STATION

The Sapphire switch force-displacement test station is designed for accurate, repeatable force, electrical, and displacement measurements of various types of tactile switches and switch assemblies. The Sapphire is a stand-alone unit that tests and displays precise measurement data on an LCD touch screen display. You can upload full measurement reports to your network or a USB drive.

The Sapphire tests metal domes, poly domes, membrane switches, and most other switches. The force test station follows ASTM standard F2592. Tests include trip force, return force, standing free height, displacement (travel), tactile ratio, tactile activation slope, switch resistance, and more. In addition, it can detect two separate electrical contacts, and users can use it to characterize resistive touch screens.

HOW IT WORKS

The Sapphire™ comes complete with a 5" LCD touch screen, testing platform, adjustable stand, interchangeable test probe and resistance test cables:

- › An adjustable test head is included to accommodate for a wide range of product heights.
- › Users select specific characteristics to measure and receive reports directly from the screen.
- › The Sapphire test station is pre-programmed, so data and in-depth reports are generated through Excel over your network.
- › The Sapphire has two USB ports that will save reports when a drive is detected.

Note: Custom test probes, test plates, and calibration kit sold separately. Custom specifications available.

The Sapphire is also available for lease. Visit our website for more information, terms, and conditions.

TERM	PRICE PER MONTH
3-Year	\$400
2-Year	\$500
1-Year	\$650
Month-to-Month	\$800



METAL DOMES

- › Most of our metal domes are designed to be depressed to flat and no further. Depressing a dome past flat, or the outer perimeter or feet of the dome, can cause a loss in tactile feel or cause the dome to fail. Always place the dome on a hard flat surface. The contact area must be level with the outer perimeter or feet of the dome. Failure to do this may result in a damaged or bistable dome. The only standard series of domes designed to be over-traveled are the M-series.
- › Always use a tool or gloves when placing metal domes. Touching them with your bare skin could contaminate the dome surface and affect contact resistance.
- › Domes should be supported when activated. Always place domes on a flat hard surface. Never activate a dome when all feet are not evenly supported.
- › Dome “Nesting”—Dome nesting occurs when two or more domes “nest” together (double domes) when placed. Double doming can be detected through force testing your applications. Both the SureShot Automated Dome Placement Machine and the Dart Dome Placement Pen placement products eliminate double domes.

PEEL-N-PLACE ARRAYS

- › Before applying a Peel-N-Place array, it is essential to have a clean surface area to ensure proper adhesion and minimize contamination. Snaptron recommends that you keep all surfaces clean, dry, and free of debris. Isopropyl alcohol can be used with a non-lint cloth.
- › Peel-N-Place adhesive material should be applied to the board after any soldering/reflow soldering takes place.
- › Do not stretch or over tension the Peel-N-Place array when applying to your surface area. This could affect the placement tolerances of the dome positions and adversely affect adhesion. Therefore, the use of an application fixture is highly recommended (see page 20).
- › Static is generated when the paper release liner is removed from the carrier tape. To help combat this condition, we recommend the operator use a static workstation with a strap and ground. In addition, you can also use ionized air to reduce static. Cleanliness of your work area is very important as any lint or dust may be drawn in by the exposed cover material.

DAMAGE CAN OCCUR TO THE DOME BY ANY OF THE FOLLOWING MEANS:

- › Over-travel of a dome past flat (level) or its designed travel can cause damage to the dome. For most domes, this means traveling the center of the dome past the flat plane of the feet. Actuating the dome between the fingers with the center unsupported is an example of over-travel that can result in a damaged or bi-stable dome.
- › Denting the dome can be caused by actuating the dome with a sharp object such as a pen or fingernail. (Rubbing the finger across the dome with the fingernail, for example.)
- › Depressing the dome with a rigid, flat surface that is too large can cause damage. A dome actuator should be no larger than 25% of the dome diameter.
- › Depressing the dome across the entire width of the dome with some type of roller can cause damage. Use caution when applying and smoothing the PNP cover material.
- › Actuating the dome when all of the feet are not evenly supported can damage the dome.

Note: These are the most common causes of damage to the metal domes during assembly, yet do not include all sources caused by general rough handling.

QUALITY ASSURANCE

Snaptron is committed to quality and the achievement of excellence throughout all company activities. Since 1998, Snaptron has been an ISO 9001 registered company. To provide our customers with the best possible products and services, we seek to constantly improve manufacturing processes, testing and measurement techniques, and the overall performance of our quality management system.

ISO 9001:2015 Compliance

The Snaptron Quality Policy is established and structured to provide ISO 9001:2015 compliant quality management. Our quality management system is designed to provide the highest satisfaction for our customers with defect-free products that conform to their requirements and are delivered on time. Snaptron communicates its commitment to quality within the organization through the provision of resources, leadership, and quality objectives. By monitoring and reviewing the quality management system, we will ensure its continual improvement and effectiveness.

RoHS Compliance

Snaptron’s metal domes and Peel-N-Place arrays comply with Directives 2011/65/EU, 2003/11/EC, and 2015/863 EU. Snaptron’s products do not contain any of the following hazardous substances as defined in the above directives:

- › Lead
- › Mercury
- › Cadmium
- › Hexavalent chromium
- › Pentabromodiphenyl ether (PentaBDE)
- › Octabromodiphenyl ether (OctaBDE)

Snaptron metal dome switches are manufactured from 300 series stainless steel per ASTM A666 and ASTM A480/A480M, for chemical composition and physical properties. The carrier for the dome array, if applicable, is a clear polyester film (PET) with 1 or 2 mil acrylic adhesive and Kraft paper release liner.

REACH Compliance

Snaptron provides customers with tactile dome switch products manufactured from 300 series stainless steel, which may or may not be placed on an adhesive polyester carrier material. After reviewing the REACH Directive and various Guidance documents, Snaptron has determined that its products are classified as Articles. REACH, 3(3) defines an Article as: “An object which during production is given a special shape, surface or design which determines its function to a greater degree than does its chemical composition.” In addition, Snaptron products contain no chemicals or substances of concern for intentional release during use; therefore, Snaptron products are not subject to the registration process required per REACH.

DFARS Compliance

Snaptron provides customers with tactile dome switch products manufactured from 300 series stainless steel. After a review of various guidance documents, Snaptron has determined that stainless steel is a specialty metal as defined in DFARS 252.225-7014 Alt 1. The specialty metal used in all Snaptron products is melted in the United States or a qualifying country, in compliance with the DFARS requirement. In preparing this response, Snaptron has relied on information provided by its suppliers.

QUALITY AND TESTING

FORCE AND LIFE

FORCE TESTING

Snaptron performs force testing with our Sapphire Force Displacement Test Station. In addition to testing our products internally, Snaptron can be contracted to perform mechanical or electrical force testing of your products according to your specified requirements or in your final assembly. Snaptron offers testing services for characterization and/or mechanical cycle testing of fully assembled switches and products. We accept projects on a case-by-case basis.

TRIP FORCE (ACTUATION FORCE) MEASUREMENT:

Equipment

- › Machine – Electronic force-displacement test gauge.
- › Test Probe – 0.050" (1.27mm) diameter with a flat bottom for domes 5mm and greater, or 0.032" (0.81mm) diameter with a flat bottom for domes less than 5mm (0.197") (test method recommended ASTM 2592).
- › Fixture Pocket – Steel with milled recess for the dome to be placed in for proper centering.

Setup

- › Position the center of the dome to be tested within 0.010" (0.25mm) of the test probe center. The test probe must be perpendicular to the dome.
- › The dome must be on a hard flat surface and needs to be vented to avoid air entrapment. Air trapped under the dome will increase the trip force and give a false reading.
- › Dome should be clean and free of carrier tape or adhesive.

Measuring

- › Test speed 0.050" [1.27mm] per second.
- › Pre-condition the dome with ten actuations using a 0.050" (1.27mm) test probe.
- › On the 11th cycle, the gauge will collect dome characteristic results

LIFE TESTING

In addition to testing our products internally, Snaptron can be contracted to perform mechanical, electrical life cycle testing, or other characteristics for your specific application.

Setup

- › Domes are tested on a hard flat steel surface perpendicular to the actuator test probe, with the probe positioned slightly over the top of the dome.
- › The actuator test probe is a Delrin plastic centered over the dome within +/- 0.015" [0.38mm].
- › Dome is attached using polyester tape, a type of pressure-sensitive adhesive, and must provide venting for the dome.

Testing

- › The test runs continuously at 3-10 cycles per second.
- › The actuator test probe is 20-25% of the dome's diameter.
- › Maximum test force load is calculated as follows: Dome trip force + Upper trip force tolerance + 100 grams = Test Force (ex. F08400: 400+30+100 = 530 maximum test force).
- › Life cycle testing is performed following ASTM F1578 (standard practice for contact closure cycling of a membrane switch), less electrical resistance testing.

Dome Failure

Failure is defined as a dome failing to make or break mechanical contact (e.g., cracking) before the specified cycle rating.



TERMS AND DEFINITIONS

ASTM: American Society for Testing and Materials.

Bistable: The condition of a dome where, when actuated and then released, the dome inverts and does not return to its original open position. In this state, the dome exhibits two stable conditions (open and closed).

Break force (Fb): The force at electrical contact break.

Contact bounce: The time during switching in which electrical instability caused by the rebound of the contacts is observed and measured in milliseconds.

Contact break: Opening the circuit.

Contact closure: The event at which a specified resistance is achieved.

Contact force (Fc): The force at electrical contact closure.

Contact resistance: Electrical resistance as measured between two test points (e.g., a dome contact and a circuit pad) whose internal contacts, when held closed, complete a circuit.

Contamination: Refers to debris that can gather on a circuit pad that may interfere with electrical function.

Displacement/travel: Measured distance of movement when a dome switch is depressed.

Force-Displacement Curve: (1) the amount of force needed to actuate a switch from its open position to a closed position, and (2) the amount of travel the switch undergoes from the open position to the closed position.

Flexible circuit: An arrangement of printed wiring utilizing flexible base material.

Free height: The total height of a dome in its relaxed state after pre-conditioning.

Make: Closing or completing the circuit.

Mechanical life: The number of complete cycles (open to closed, then back to open) a switch can achieve before mechanical failure.

Membrane switch: A momentary switch panel in which at least one contact is on, or made of, a flexible substrate. Typically has four or more layers, whereas the top layer is the graphic user interface, and the bottom layer is a printed circuit. Layers generally are held together with a pressure-sensitive adhesive.

Momentary switch: A switch with contacts made with actuating force and released when that force is removed.

Normally open: Dome contacts are open when the switch actuator is in its un-actuated or resting position.

Over-travel: Actuating the dome past its designed travel. For most domes, this is beyond the flat plane of the feet.

Peel-N-Place (PNP): The term Snaptron uses to describe metal dome contacts on adhesive tape for placement on the desired surface (e.g., PCBs or flex circuits).

Pre-conditioning: The dome must be pre-conditioned by actuating the dome ten times with a specified test probe.

Pole: The number of separate circuits that can be activated through a switch at any one time. A single pole switch allows one closed circuit at a time. A double pole circuit allows two closed circuits.

Pre-load: Pre-load is a condition in which pressure is applied prior to actuating the dome. To prevent pre-load, the dome must be in a relaxed state when inactivated. Designs where the overlay and the PCB are compressing the dome result in the dome being stressed, affecting the dome's characteristics, including travel, force and life.

Printed circuit board (PCB): An electronic circuit used in devices to provide mechanical support and a pathway to its electronic components.

Release force: The amount of force the dome exerts on itself to return to its relaxed state.

Spacer pocket/venting layer: A pocket (typical in membrane applications) where the dome is secured between a printed circuit (bottom) and a graphic overlay (top). Vent tracks connect pockets to allow air to escape when a dome is actuated.

Surface Mount Device (SMD): An electronic component that gets placed onto a circuit board.

Surface Mount Technology (SMT): A method in which electrical components are mounted directly onto a circuit board (PCB) or flex circuit.

Switching capacity: The number of volts multiplied by amps.

Tactile response: A sensation caused by a sudden collapse or snap back, or both, of a switch. For calculation methods, see the two items below.

Tactile response/recovery as a percent: Measurement of tactile response $100 * (F_{max} - F_{min}) / F_{max}$.

Tactile response/recovery as a slope: Measurement of tactile response $(F_{max} - F_{min}) / (T_{fmax} - T_{fmin})$.

* Note: To obtain additional information about the two items above, refer to ASTM Standard F2592.

Tease: A displacement measurement between contact break and Release force.

Throws: Number of circuits that can be controlled by any one pole of a switch. For example, in a single-pole, double-throw (SPDT) switch, only one circuit may be completed at a time. However, there are two possible circuits (throws) that can be made.

Transition Ring: The transition ring is the visible ring on the top of the dome, where the dome radius transitions into the feet/legs of the dome. The transition ring is the hinge point of the dome that forces the dome back to its original shape after the dome has been depressed or snapped over.

Travel: The total distance the dome switch moves from its relaxed state to electrical contact.

Trip force: The amount of force that is necessary for the dome to "snap," changing the dome from the open position to the closed position.

Venting: Allows trapped air to escape allowing a dome to function properly.

Voltage: The electrical force or "pressure" that causes current to flow into a circuit.



snaptron.com
970.686.5682

960 Diamond Valley Drive
Windsor, CO 80550