

SEP 2022

AUTOMOTIVE PRODUCT SELECTION GUIDE

WWW.RICHTEK.COM

RICHTEK

COPYRIGHT © RICHTEK TECHNOLOGY CORPORATION.



JOIN MYRICHTEK

Create an account with us for free samples, datasheet alerts and more.



SUBSCRIBE OUR NEWSLETTERS

Subscribe to our e-newsletters to receive updates on the latest product information.



FOLLOW US ON FACEBOOK

Connect with us and stay tuned!



SUBSCRIBE OUR YOUTUBE CHANNEL

Subscribe and stay informed!



FOLLOW US ON LINKEDIN

Connect with us and stay tuned!



FOLLOW US ON WECHAT

Join us and stay informed!

About RICHTEK

Who We Are

Founded in 1998, Richtek is one of the leading global analog semiconductor companies in design and development of comprehensive power management ICs for consumer electronics, computers, communications equipment, industrial and automotive products. After the completion of merger with MediaTek in 2016, Richtek has broadened the product range for more diverse applications.

Richtek not only delivers the industry's innovative power management ICs, but also provides the complete system design-in service and support. With Richtek as "Your Power Partner" you can spend less time trouble-shooting issues with power management and more time working on your next big product.

What We Offer

Richtek offers comprehensive power solutions that range from DC/DC regulators to power management multi-channel ICs. Richtek aims to accelerate your design with design support, such as *Richtek Designer™* the powerful online design generator and simulation tool, application notes, technical documents, and more. Additionally, you can sign up for 'My Richtek' for free samples, a selection of evaluation boards (EVBs) and the latest Richtek *technical and product newsletters*.

Quality and Reliability Commitment

Richtek has established an innovative and dynamic quality management system. As a result of this system, we have attained and continued to maintain ISO 9001, ISO 14001, ISO 45001 and ISO 26262 certification. Richtek is committed to protecting the environment and conforming to the regulation requirements with the declaration of RoHS, the declaration of REACH and more green product files for *download*.

Wide ranges of automotive power ICs from Richtek in different applications

- ◆ Infotainment: Controller operating panel (HMI) and display, head-up display, head unit, Audio, Video, navigation (AVN) and others.
- ◆ Advanced Driver Assistance Systems: Multi-camera system with central processing (AVM), mmWave radar, rear and front camera, and others.
- ◆ Others including Power Switch, LED lighting, USB PD solutions and so on.
- ◆ You can find automotive system block diagrams on our *Applications webpages* for more details.

Automotive Design Considerations

- ◆ Products connected to the vehicle battery rails require 36V input voltage to support load dump and down to 4.5V for start-stop. The output voltages of systems normally range from 1.8V to 5V. In some cases, such as cold-crank where battery rail can drop as low as 3V during cranking of the engine, it is not possible to maintain regulation when input voltage approaches the regulated voltage, and some voltage drop is allowed.
- ◆ Devices for vehicle interface processors in subsystems require input voltage up to 5.5V. The vehicle subsystem monitors temperature, voltage levels, etc.
- ◆ A radio receiver nearby has high sensitivity in electromagnetic fields in its operating bands and will easily be affected by converter switch noise. Selecting a suitable switching frequency can help to avoid radiating noise in sensitive frequency bands. Richtek provides products with programmable switching frequency, which allows best trade-off between efficiency and component size. Some products with external clock synchronization can be set to avoid sensitive frequency bands and shift the second harmonic out of the tuned frequency band.
- ◆ Richtek also provides products with the low quiescent and low shutdown current, which are ideal for devices in standby mode.

Table of Contents

Buck Converters	06
LV Buck Converters: Vin up to 6.5V	06
HV Buck Converters: Vin up to 60V	06
LDOs	10
Boost Converter	10
Backlight LED Drivers	10
Operational Amplifier	12
Level Shifter	12
PMICs	12
Audio Amplifier	14
DDR Memory Power ICs	16
Power Switch	16
Supervisor	16
USB Type-A/C DFP with Charging Port and Integrated Buck Converters	18
USB Type-C PD and PWM Controllers with AnyPower™ and PD Safe® Features	18
Featured Products	20

Buck Converters

LV Buck Converters: Vin up to 6.5V

AEC-Q100	Part Number	Vin		Vout		Iout max (A)	Freq (MHz)	Ron		Iq typ (mA)	PSM / Force PWM	Control Mode	Adj. Soft-Start	Power Good	Features	Package(s)	Applications
		min (V)	max (V)	min (V)	max (V)			HS typ (mΩ)	LS typ (mΩ)								
Grade 1	RTQ2102A-QA	3	6	0.45	3.3	1.5	2.7	110	90	0.03	PSM	ACOT	-	Y	Fast Transient Response; 100% Duty-Cycle	WDFN3x3-8	Infotainment, Car Connectivity, TBOX
Grade 1	RTQ2103A-QA	3	6	0.45	3.3	2	2.7	130	105	0.03	PSM	ACOT	-	Y	Fast Transient Response; 100% Duty-Cycle	PSOP-8	Infotainment, IVI, TBOX
Grade 2	RT2101B	2.95	6	0.827	3.6	2	0.7~2	45	42	0.55	Force PWM	CM	Y	Y	Ext. Comp.; Ext. Sync.	WQFN3x3-16	Digital Cluster with Video Input
Grade 2	RT2101A	2.95	6	0.827	3.6	3	0.7~2	45	42	0.55	Force PWM	CM	Y	Y	Ext. Comp.; Ext. Sync.	WQFN3x3-16	Vehicle Electronics
Grade 1	RTQ2158-QA	2.85	6.5	0.6	3.3	8	2.1	15	10	0.5	Force PWM	ACOT	Y	Y	Hiccup Mode UVP	WET-WQFN4x4-21(FC)	Infotainment, Car Connectivity
Grade 1	RTQ2159-QA	2.85	6.5	0.6	1.5	8	0.46/0.69/ 0.92/ 2.1	15	10	0.5	Force PWM	ACOT	Y	Y	Hiccup Mode UVP; VID Control Range via I ² C	WET-WQFN4x4-21(FC)	Infotainment, Car Connectivity

HV Buck Converters: Vin up to 60V

AEC-Q100	Part Number	Vin		Vout		Iout max (A)	Freq (MHz)	Ron		Iq typ (mA)	PSM / Force PWM	Control Mode	Adj. Soft-Start	Power Good	Features	Package(s)	Applications
		min (V)	max (V)	min (V)	max (V)			HS typ (mΩ)	LS typ (mΩ)								
Grade 1	RTQ2940-QA	4	42	0.8	42	0.5	0.1~2.5	170	-	0.09	PSM	CM	Y	Y	Asynch.; 100% Duty-Cycle; FMEA Compliant	PSOP-8; WDFN3x3-10S	Vehicle Accessories, TBOX
Grade 1	RTQ2960-QA	4	60	0.8	60	0.5	0.1~2.5	170	-	0.09	PSM	CM	Y	Y	Asynch.; 100% Duty-Cycle; FMEA Compliant	PSOP-8; WDFN3x3-10S	Vehicle Accessories
Grade 1	RTQ2130B-QT	3	36	0.8	36	0.7	2.1	200	160	1.1	Force PWM	CM	-	-	Ext. Comp; 100% Duty-Cycle	WDFN2x3-8S	ADAS
Grade 1	RTQ2131B-QA	3	36	0.8	36	1	2.1	200	160	1.1	Force PWM	CM	-	Y	Ext. Comp; Spread-Spectrum; 100% Duty-Cycle	WDFN3x3-10S	ADAS
Grade 1	RTQ2132B-QT	3	36	0.8	36	1.2	2.1	200	160	1.1	Force PWM	CM	Y	Y	Ext. Comp; Spread-Spectrum; 100% Duty-Cycle	TSSOP-14(PP)	ADAS
Grade 1	RTQ2941-QA	4	42	0.8	42	1.5	0.1~2.5	160	-	0.09	PSM	CM	Y	Y	Asynch.; 100% Duty-Cycle; FMEA Compliant; Spread-Spectrum	PSOP-8; WDFN3x3-10S	Vehicle Accessories
Grade 1	RTQ2961-QA	4	60	0.8	60	1.5	0.1~2.5	160	-	0.09	PSM	CM	Y	Y	Asynch.; 100% Duty-Cycle; FMEA Compliant; Spread-Spectrum	PSOP-8; WDFN3x3-10S	Vehicle Accessories
Grade 1	RTQ2942-QA	4	42	0.8	42	2.5	0.1~2.5	150	-	0.09	PSM	CM	Y	Y	Asynch.; 100% Duty-Cycle; FMEA Compliant; Spread-Spectrum	PSOP-8; WDFN3x3-10S	Vehicle Accessories

AEC-Q100	Part Number	Vin		Vout		Iout max (A)	Freq (MHz)	Ron		Iq typ (mA)	PSM / Force PWM	Control Mode	Adj. Soft-Start	Power Good	Features	Package(s)	Applications
		min (V)	max (V)	min (V)	max (V)			HS typ (mΩ)	LS typ (mΩ)								
Grade 1	RTQ2962-QA	4	60	0.8	60	2.5	0.1~2.5	150	-	0.09	PSM	CM	Y	Y	Asynch.; 100% Duty-Cycle; FMEA Compliant; Spread-Spectrum	PSOP-8; WDFN3x3-10S	Vehicle Accessories
Grade 2	RT2875BQ	4.5	36	0.6	24	3	0.3~2.1	95	70	1.3	Force PWM	CM	Y	Y	Adj. Current Limit; 100% Duty-Cycle; Hiccup Mode UVP	TSSOP-14(PP)	Vehicle Electronics
Grade 1	RTQ2104-QA	3	36	0.8	36	3	2.1	80	80	0.04	PSM	CM	-	Y	100% Duty-Cycle; Spread-Spectrum	PSOP-8	IVI, Display, TBOX
Grade 1	RTQ2104B-QA	3	36	0.8	36	3	2.1	80	80	1.2	Force PWM	CM	-	Y	100% Duty-Cycle; Spread-Spectrum	PSOP-8	IVI, Display, TBOX
Grade 1	RTQ2105-QA	3	36	0.8	36	3	0.3~2.2	70	70	0.04	PSM/ Force PWM	CM	Y	Y	100% Duty-Cycle; Spread-Spectrum	WET-WQFN4x4-24S	IVI, Display
Grade 1	RTQ2106-QA	3	36	0.8	36	3	0.3~2.2	90	90	0.04	PSM/ Force PWM	CM	Y	Y	100% Duty-Cycle; Spread-Spectrum	TSSOP-14(PP)	ADAS
Grade 1	RTQ2949-QA	4	42	0.8	42	3	0.1~2.5	150	-	0.09	PSM	CM	-	-	Asynch.; 100% Duty-Cycle; FMEA Compliant; Spread-Spectrum	PSOP-8	Vehicle Accessories
Grade 1	RTQ2949A-QA	4	42	0.8	42	3	0.1~2.5	150	-	0.09	PSM	CM	-	-	Asynch.; 100% Duty-Cycle; FMEA Compliant; Spread-Spectrum	PSOP-8	Vehicle Accessories
Grade 1	RTQ2943-QA	4	42	0.8	42	3.5	0.1~2.5	80	-	0.1	PSM	CM	Y	Y	Asynch.; 100% Duty-Cycle; FMEA Compliant; Spread-Spectrum	PSOP-8;WDFN4x4-10	IVI,Display, TBOX
Grade 1	RTQ2963-QA	4	60	0.8	60	3.5	0.1~2.5	80	-	0.1	PSM	CM	Y	Y	Asynch.; 100% Duty-Cycle; FMEA Compliant; Spread-Spectrum	PSOP-8;WDFN4x4-10	Vehicle Accessories
Grade 1	RTQ2174-QA	3	36	1	25	4	0.2~2.3	24	20	0.007	PSM/ Force PWM	CM	-	Y	SRSS; FMEA Compliant; Spread-Spectrum	WET-WQFN4x4 -16(FC)	ADAS,TBOX
Grade 1	RTQ2945A-QA	4	42	0.8	42	5	0.1~2.5	70	-	0.1	PSM	CM	-	-	Asynch.; 100% Duty-Cycle; FMEA Compliant; Spread-Spectrum	PSOP-8	Vehicle Accessories
Grade 1	RTQ2965-QA	4	60	0.8	60	5	0.1~2.5	70	-	0.1	PSM	CM	Y	Y	Asynch.; 100% Duty-Cycle; FMEA Compliant; Spread-Spectrum	PSOP-8;WDFN4x4-10	Vehicle Accessories
Grade 1	RTQ2176-QA	3	36	1	25	6	0.2~2.3	24	20	0.007	PSM/ Force PWM	CM	-	Y	SRSS; FMEA Compliant; Spread-Spectrum	WET-WQFN4x4 -16(FC)	ADAS, TBOX
Grade 1	RTQ2178-QA	3	36	1	25	8	0.2~2.3	24	20	0.007	PSM/ Force PWM	CM	-	Y	SRSS; FMEA Compliant; Spread-Spectrum	WET-WQFN4x4 -16(FC)	ADAS, TBOX
Grade 1	RTQ2179-QA	3	36	1	25	10	0.2~2.3	24	20	0.007	PSM/ Force PWM	CM	-	Y	SRSS; FMEA Compliant; Spread-Spectrum	WET-WQFN4x4 -16(FC)	ADAS, TBOX

LDOs

AEC-Q100	Part Number	Vin		Vout		Iout	Iq	Vdropout@ rated current	Features	Package(s)	Applications
		min (V)	max (V)	min (V)	max (V)	max (mA)	typ (uA)	typ (mV)			
Grade 3	RT2560Q	3.5	36	2.5	12	100	2	320@0.01A	Fixed Vout: 2.5V, 3.3V, 5V, 12V	PSOP-8	Vehicle Electronics
Grade 1	RTQ2569-QA	3.5	36	2.5	12	100	2	200@0.01A	Enable Input	WDFN3x3-8	IVI, Display, TBOX
Grade 1	RTQ2510-QA	2.2	6	0.8	5.5	1000	190	170@1A	Enable Input	VDFN3x3-8	Digital Cluster with Video Input, TBOX
Grade 2	RT2517B	2.2	6	1.2	5	1000	700	200@1A	Enable Input	PSOP-8	IVI, Display
Grade 2	RTQ2516-QT	1.4	6	0.5	5.5	2000	700	240@2A	Enable Input	PSOP-8	IVI

Boost Converter

AEC-Q100	Part Number	Vin		Vout		SW Current Limit	Iq	Freq	Switch Ron	PSM / Force PWM	Features	Package(s)	Applications
		min (V)	max (V)	min (V)	max (V)	typ (A)	typ (mA)	typ (kHz)	typ (Ohm)				
Grade 2	RTQ9297-QT	2.6	5.5	2.6	24	3.8	0.5	640; 1200	0.125	Force PWM	Adj. Soft-Start; Enable Input	WDFN3x3-10S	Display

Backlight LED Drivers

AEC-Q100	Part Number	Vin		Vout	LED Channels	Topology	SW Freq	Iout per Channel	Dimming Control	Features	Package(s)	Applications
		min (V)	max (V)	max (V)			(MHz)	max (mA)				
Grade 3	RT8577A	5.5	40	45	4	Boost	0.2-2.1	120	PWM	Open/Short Protection; Adj. OVP; Abnormal Status Indicator for OVP/Short/OTP Condition	WQFN5x5-20	Display
Grade 1	RTQ4546-QT	3	40	45	6	Boost SEPIC	0.3-2.2	200	PWM with I ² C or PWM Input	I ² C Control; Embedded Memory with MTP; Automatic Phase Shift PWM Dimming	QFN4x4-24	Display
Grade 1	RTQ4547-QT	3	40	45	6	Boost SEPIC	0.3-2.2	200	PWM with I ² C or PWM Input	I ² C Control; Embedded Memory with MTP; Automatic Phase Shift PWM Dimming; LED Dimming/Fsw Setup via External Resistors	VDFN9.8x6.4-38	Display

Operational Amplifier

AEC-Q100	Part Number	Vs		Voffset	Ipeak	Slew Rate	Features	Package(s)	Applications
		min (V)	max (V)	typ (mV)	typ (mA)	(V/us)			
Grade 2	RTQ9148-QT	6	20	2	350	35	Rail to Rail Swing; High Speed; High Peak Current	WDFN3x3-6	Display

Level Shifter

AEC-Q100	Part Number	Description	Vout Range (V)	Regulator Blocks	Interface	Features	Package(s)	Applications
Grade 2	RTQ8945-QT	High Voltage Level Shifter for Automotive Panel	-18 ~ 28	24 outputs: D1_out to D15_out; D1B_out to D8B_out; XAO_out	-	UVLO, OTP, OCP Protection	WQFN7x7-56	GIP OLED or LCD panels

PMICs

AEC-Q100	Part Number	Description	Vin Range (V)	Regulator Blocks	Interface	Features	Package(s)	Applications
Grade 2	RTQ6513-QT	10-Bit Programmable Gamma Reference for TFT-LCD Panel	2.9-18	16x Gamma Correction; 1x VCOM Operational Amplifier; 1x Rail to Rail HAVDD Buffer	I ² C	OCP, OVP, SCP Protection	WQFN5x5-32	Display
Grade 2	RTQ6749-QT-A2	TFT LCD Integrated Power Module for Automotive Infotainment Applications	2.5-5.5	1x 0.2A, 1x 0.06A Boost for PAVDD and VGH; 1x 0.2A Buck-Boost for NAVDD; 1x 0.06A VGL Charge Pump; 1x VCOM 8 bits; 1x RESET Voltage Detector	I ² C	Power-on/off Sequence Free; Outputs Power-off Discharge Function; Programmable Voltage Detector; Built in UVLO, UVP, OVP, SCP and OTP	WDFN5x5-32	Display
Grade 2	RTQ6752-QT	TFT LCD Integrated Power Module for Automotive Infotainment Applications	2.5-5.5	1x 0.2A Boost for PAVDD; 1x 0.2A NAVDD Buck-Boost; 1x 8-bit Calibrator; 1x RESET Voltage Detector	I ² C	Power-on/off Sequence Free; Outputs Power-off Discharge Function; Programmable Voltage Detector; UVLO, UVP, OVP, SCP and OTP	WET-WQFN5x5-20	Display
Grade 2	RTQ6801-QT	Boost Converter with VGH/VGL Charge Pump and High Current OP Amp for TFT-LCD Panel	2.5-5.5	1x AVDD Boost; 1x VGH Charge Pump; 1x VGL Charge Pump; 1x Gate Pulse Modulator	-	Incorporate One Gate Shading Functions with Adjustable Falling Time	WQFN4x4-24	Display
Grade 2	RTQ8306-QT	36-Channel Current Sink LED Driver for Local Dimming Applications	5	36CH Constant Current LED Driver; 12-bit PWM Control	SPI	5mA to 60mA Current; 8-Bit Resolutions; Dot Correlation Function; HDR Mode; Integrated Dynamic Headroom Control	WQFN7x7-56	Display, Animated Lighting
Grade 2	RTQ6751-QT	PMIC for AMOLED Panels	2.8-5	1x 0.8A Sync./Async. Boost for AVDD; 1x 1A Buck for VCORE; 1x 0.3A Buck for VIO; 1x 0.1A Negative Inverting for VGL; 1x Negative OP Amp. for VINI; 1x 0.15A Boost for VGH; 2x Gamma Buffers	I ² C	Programmable Voltage Detector; UVLO, UVP, OVP, SCP, and OTP Protection; EEPROM Memory	UQFN5x5-32(FC)	Display

AEC-Q100	Part Number	Description	Vin Range (V)	Regulator Blocks	Interface	Features	Package(s)	Applications
Grade 1	RTQ2071A-QA	4-Regulator PMIC for Power over Coax Automotive Digital Camera Modules	4~18.5	1x 2A HV Buck; 1x 1.5A LV Buck; 1x 0.75A LV Buck; 1x 0.3A LDO	PoC	FMEA Compliant; 10 Adj. Output Settings; 10 Flexible Power Sequence; Sequence Control for External Power IC via SEQOUT	WETD-VQFN3x3-16	ADAS
Grade 1	RTQ2071B-QA	4-Regulator PMIC for Power over Coax Automotive Digital Camera Modules	4~18.5	1x 2A HV Buck; 1x 1.5A LV Buck; 1x 0.75A LV Buck; 1x 0.3A LDO	PoC	FMEA Compliant; 10 Adj. Output Settings; 10 Flexible Power Sequence; Power Status Indication via PG; 3.8V UVLO_H Setting	WETD-VQFN3x3-16	ADAS
Grade 1	RTQ2072B-QA	4-Regulator PMIC for Power over Coax Automotive Digital Camera Modules	4~18.5	1x 2A HV Buck; 1x 1.5A LV Buck; 1x 0.75A LV Buck; 1x 0.3A LDO	PoC	FMEA Compliant; 10 Adj. Output Settings; 10 Flexible Power Sequence; Power Status Indication via PG	WETD-VQFN3x3-16	ADAS
Grade 1	RT2070	4-Regulator PMIC for Automotive Digital Camera Modules	4.5~15	1x 2A HV Buck; 2x 1A LV Buck; 1x 0.5A LDO; 1x 0.5A Power Switch	I ² C	Power Sequence by Setting the Resistances of the SEQ Pin	WQFN4x4-24	ADAS
Grade 1	RTQ2078-QA	Automotive ASIL-B PMIC for Digital Camera Modules	4~28	1x 1.5A HV Buck; 2x 1.5A LV Buck; 1x 0.3A LDO	PoC	Compliance with Functional Safety ASIL-B via Safety Mechanisms; Pin to Pin RTQ2071/2 by Slightly BOM Change; Flexible Setting via OTP	WET-UQFN3x3-16(FC)	ADAS
Grade 2	RTQ5115-QA	12-Regulator PMIC with MTP Non-Volatile Memory for MT2712 Car Infotainment Chipset	3.15~5.5	1x 2.4A LV Buck; 2x 2A LV Buck; 1x 1.6A LV Buck; 8x 0.3A LDO	I ² C	MTP Memory for Parameter Pre-set; Power Sequence Programming	WQFN7x7-56	IVI
Grade 1	RTQ2077S-QT	DC-DC Converters + LDO PMIC for Industrial/Automotive Application	4.5~15	1x 0.4A HV Buck; 1x 0.2A LDO	-	Enable Input; Internal Compensation; Power Good; OCP, OVP, SCP Protection	WQFN3x3-16	ADAS
Grade 1	RTQ2134-QA	4-Phase, 2-Channel or 3-Channel High Current Buck for MT2712 Car Infotainment Chipset	3~6	2+2 Phase: 10A + 10A; 2+1+1 Phase: 10A + 5A + 5A; 4 Phase: 20A	I ² C	Remote sense; DVS with Programmable Slew-rate Control; Watch-dog Timer	WQFN4.5x5-30(FC)	IVI
Grade 1	RTQ2079-QA	System Optimization FuSa PMIC for Extremely High Image Quality Automotive Camera Sensor/Module	4~28 (36V load dump)	1x 2A HV Buck; 2x 1.5A LV Buck; 1x 0.3A LDO; 1x 0.4A LDO	I ² C	Compliance with ISO26262 ASIL-B; 12V Battery or PoC Connection; Power on BIST for OV/UV Monitor, I ² C CRC and Efuse CRC Protection	WET-WQFN4x4-24SL	ADAS

Audio Amplifier

AEC-Q100	Part Number	Description	Vin Range (V)	Regulator Blocks	Interface	Features	Package(s)	Applications
Grade 1	RTQ9128D4-QT	45W, Ultra-Low Noise, High-Efficiency, Digital Input 4-Channel Automotive Audio Amplifier with I ² C Diagnostics	4.5~26.4	4x22W, THD+N=1%, 4Ω, 14.4V; 4x27W, THD+N=10%, 4Ω, 14.4V; 4x45W, THD+N=10%, 2Ω, 14.4V; 4x75W, THD+N=10%, 4Ω, 25V	I ² S	Built-In Anti-Pop Function; Thermal Fold-Back and Clip Detection; Load Diagnostics	LQFP10x10-64	IVI

DDR Memory Power ICs

AEC-Q100	Part Number	Supported DDR type	Vin		VTT Output Tolerance	Isource/Isink	Current Limit	Features	Package(s)
			min (V)	max (V)	max (+/- mV)	max (A)	typ (A)		
Grade 1	RTQ2536-QA	DDR1/2/3/4; LP3/4	1	3.5	30	±2	2	S3; S5; VDDQ Sense; REFOUT; VTT Sense; MLCC Stable	WDFN3x3-10S
TA: -40°C to 85°C	RT2526Q	DDR2/3; LP2/3	3.1	3.6	20	±2	3.3	S3; VTTSNS Remote Sensing; MLCC Stable	SOP-8

Power Switch

AEC-Q100	Part Number	Vin		Current Limit	Ron	Iq	FLAG Indicator	Adj. Iocp	Features	Package(s)	Applications
		min (V)	max (V)	typ (A)	typ (mOhm)	typ (mA)					
Grade 3	RT2528A	2.5	5.5	Adj. 0.5~2.5	74	0.12	Y	Y	Built-in PMOSFET; OCP, SCP, OTP Protection	PSOP-8	Audio, Navigation & Info Systems

Supervisor

AEC-Q100	Part Number	Vin Range (V)	High Voltage Threshold Accuracy	Features	Package(s)	Applications
Grade 1	RTQ2588-QT	1.7~5.5	± 0.25% (Typ.) ± 0.6% (Full Temp. Range)	Low Iq : 3.5uA(Typ.); Window Threshold Levels: 0.5V~1.1V, 50mV/Step, 1.2V~5V, 0.1V/Step; Window Tolerance: ±4%, ±5%, ±7%, ±9% by Factory Setting	WDFN1.5x1.5-6	Supply Voltage Monitoring for FuSa Systems

USB Type-A/C DFP with Charging Port and Integrated Buck Converters

AEC-Q100	Part number	BUCK Converter			USB Charging Port Controller							Package
		Vin (V)	Iout (A)	Freq (MHz)	Supported cable type	SDP	CDP	DCP	CC1/CC2	VCONN	DFP	
Grade 1	RTQ2117A-QA	3~36	3	0.3~2.2	Type-A to Micro-B; Type-A to Lightning	√	√	√				WETD-VQFN5x5-32
Grade 1	RTQ2117C-QA	3~36	3.5	0.3~2.2	Type-C to Type-C; Type-C to Micro-B; Type-C to Lightning	√	√	√	√	√	√	WETD-VQFN6x6-40
Grade 1	RTQ2118A-QA	3~36	3	0.3~2.2	Type-A to Micro-B; Type-A to Lightning			√				WETD-VQFN5x5-32
Grade 1	RTQ2118C-QA	3~36	3.5	0.3~2.2	Type-C to Type-C; Type-C to Micro-B; Type-C to Lightning			√	√	√	√	WETD-VQFN6x6-40

USB Type-C PD and PWM Controllers with AnyPower™ and PD Safe® Features

AnyPower™: Constant Voltage Output in 10-Bit Resolution & Constant Current Output Settings in 9-Bit Resolution.

PD Safe®: Adjustable Converter Input Current Limit, Programmable VBUS OVP and VO UVP, Adjustable External OTP & VCONN1/2 Output Current Limit.

AEC-Q100	Part number	Vin (V)	Vout (V)	Freq (MHz)	Key features	Package
Grade 2	RTQ7880A-QT	4~36	3~21	0.2~0.6	Buck-Boost Controller; USB PD PD3.0/PPS Certificated(TID 1080016); Built-in ARM Cortex™ M0 MCU; Support power up to 100 watts; I ² C interface & GPIOs	WQFN6x6-48
Grade 2	RTQ7881A-QT	4~36	3~21	0.2~0.6	Buck Controller; Support USB PD PD3.0/PPS; Built-in ARM Cortex™ M0 MCU; Support power up to 27 watts; I ² C interface & GPIOs	WQFN6x6-48
Grade 2	RTQ7882-QT	4.5~27	3.3~21	0.2~0.6	Buck-Boost Controller; Support USB PD PD3.0/PPS; Built-in ARM Cortex™ M0 MCU; Support power up to 100 watts; I ² C interface & GPIOs	WET-WQFN6x6-48

* All listed specifications and features may be updated, please check product datasheets for details or contact our sales offices close to you.

Featured Products

RT8577A

High Voltage 4-CH LED Driver

AEC-Q100 Grade 3 Certification

Key Features

- Wide Input Supply Voltage Range: 5.5V to 40V
- Adjustable Boost Controller Switching Frequency from 200kHz to 2.1MHz
- Programmable Channel Current
- Channel Current Matching: $\pm 1.5\%$
- External Dimming Control
- Boost MOSFET Over Current Protection
- Automatic LED Open/Short Protection to Avoid Output Over Voltage
- VCC Under-Voltage Lockout
- Adjustable Over-Voltage Protection
- Abnormal Status Indicator for OVP/Short/OTP Condition

Pin Configurations

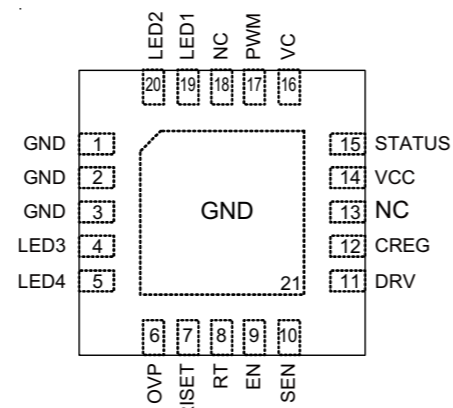

WQFN-20L 5x5

Typical Application Circuit

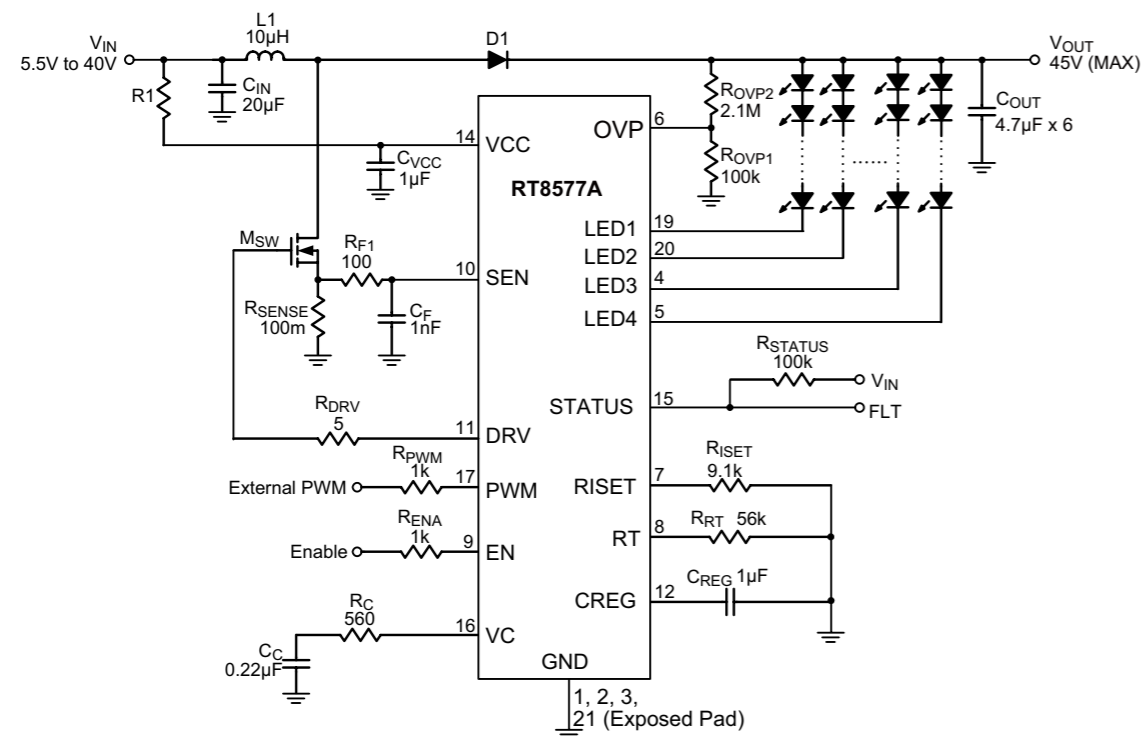

RTQ6801-QT

Boost Converter with VGH/VGL Charge Pump and High Current OP Amp for TFT-LCD Panel

AEC-Q100 Grade 2 Certification

Key Features

- 2.5V to 5.5V Input Supply Voltage
- AVDD Current-Mode Boost Converter
 - Fast Transient Response to Pulsed Load
 - High Accuracy Output Voltage: $\pm 2\%$
 - Built-In 20V, 3A, 0.16 Ω N-MOSFET
 - High Efficiency: 88%
 - Over-Current/Voltage Protection
- VGH/VGL Charge Pump Regulator
 - High Accuracy Output Voltage: $\pm 1.5\%$
 - $\pm 200\text{mA}$ Short Circuit Current
 - 45V/ μs Slew Rate
 - Rail to Rail Output
- Incorporate One Gate Shading Functions with Adjustable Falling Time

Pin Configurations

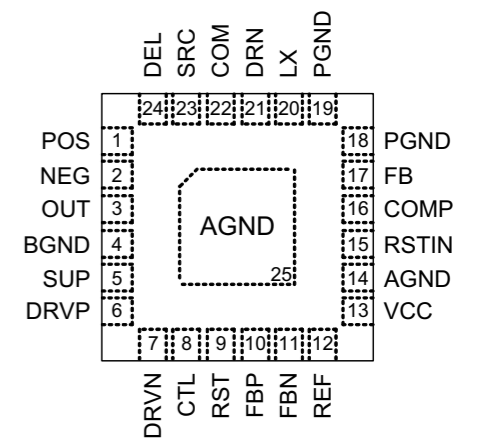

WQFN-24L 4x4

Typical Application Circuit

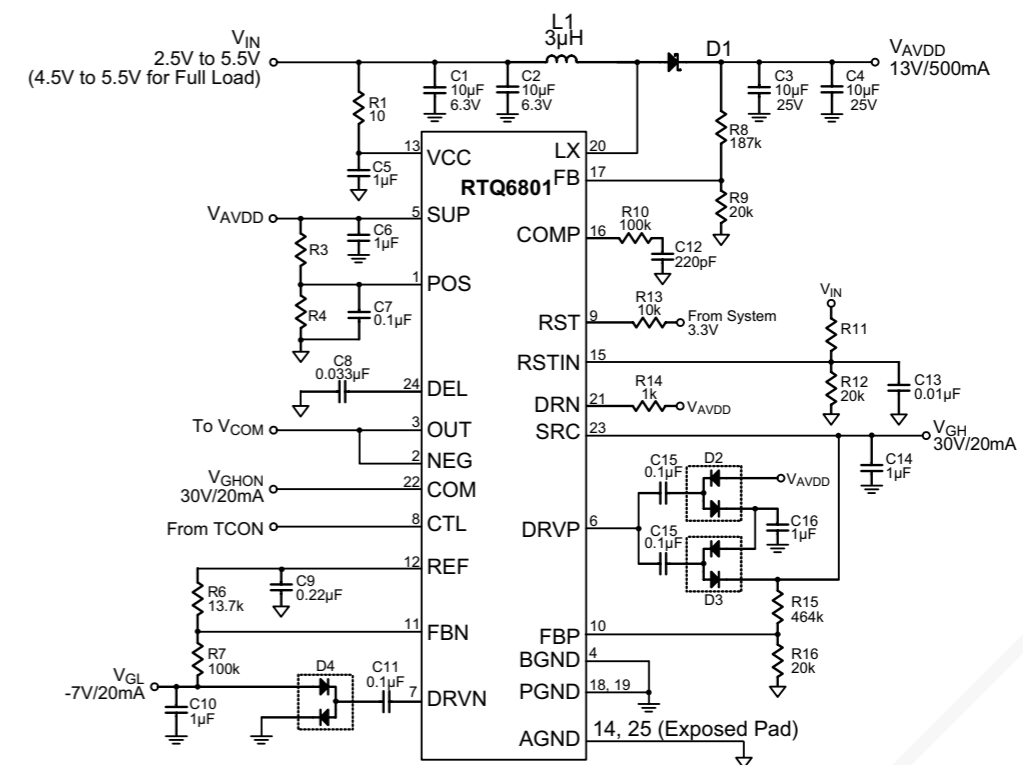

RTQ9297-QT

3A High Performance Step-Up DC-DC Converter

AEC-Q100 Grade 2 Certification

Key Features

- High Efficiency Up to 90%
- Adjustable Output Voltage: VDD to 24V
- Wide Input Supply Voltage: 2.6V to 5.5V
- Input Under-Voltage Lockout
- Pin-Programmable Switching Frequency 640kHz/1.2MHz
- Programmable Soft-Start

Pin Configurations

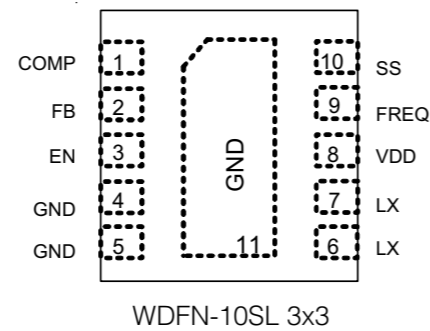

Typical Application Circuit

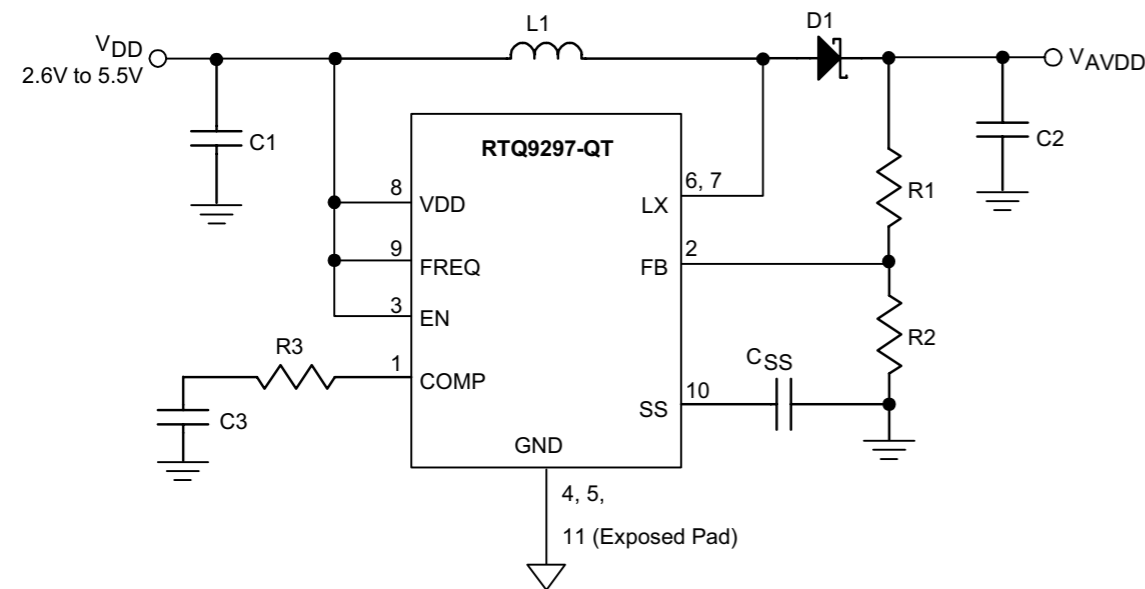

RTQ4546-QT

Automotive Display LED-backlight Controlled 6-CH Driver with I²C Interface

AEC-Q100 Grade 2 Certification

Key Features

- Input Voltage: 3V to 40V; Output Voltage: Up to 45V
- Channel Current Programmable: 30mA to 200mA
- Integrated Boost and SEPIC controller for LED Driver: Switching Frequency: 300kHz to 2.2 MHz; Spread Spectrum for Reduced EMI; Sync Input to Set Switching Frequency
- Channel Current Regulation with Accuracy $\pm 2.5\%$ and Matching 2.5%
- Dimming Controls: 32000:1 in 152Hz PWM Signal; Up to 16-Bit Dimming Resolution with I²C or PWM Input; Up to 12-Bit Analog Dimming Resolution
- Automatic Phase Shift PWM Dimming
- Automatic Output Voltage Discharged When the Controller is Disabled
- 8 Configurable LED Strings Configuration
- Embedded Memory with MTP
- Extensive Fault Diagnostics

Pin Configurations

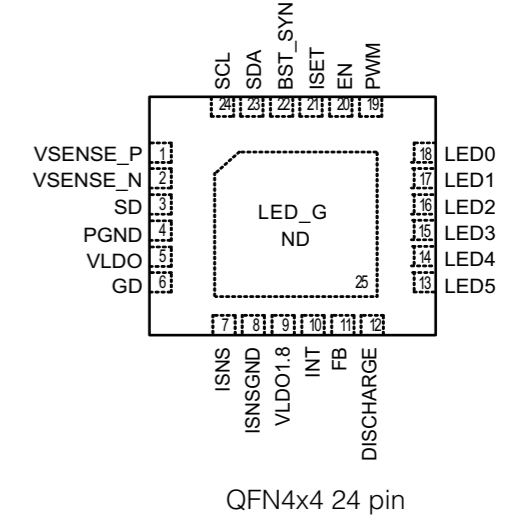

Typical Application Circuit

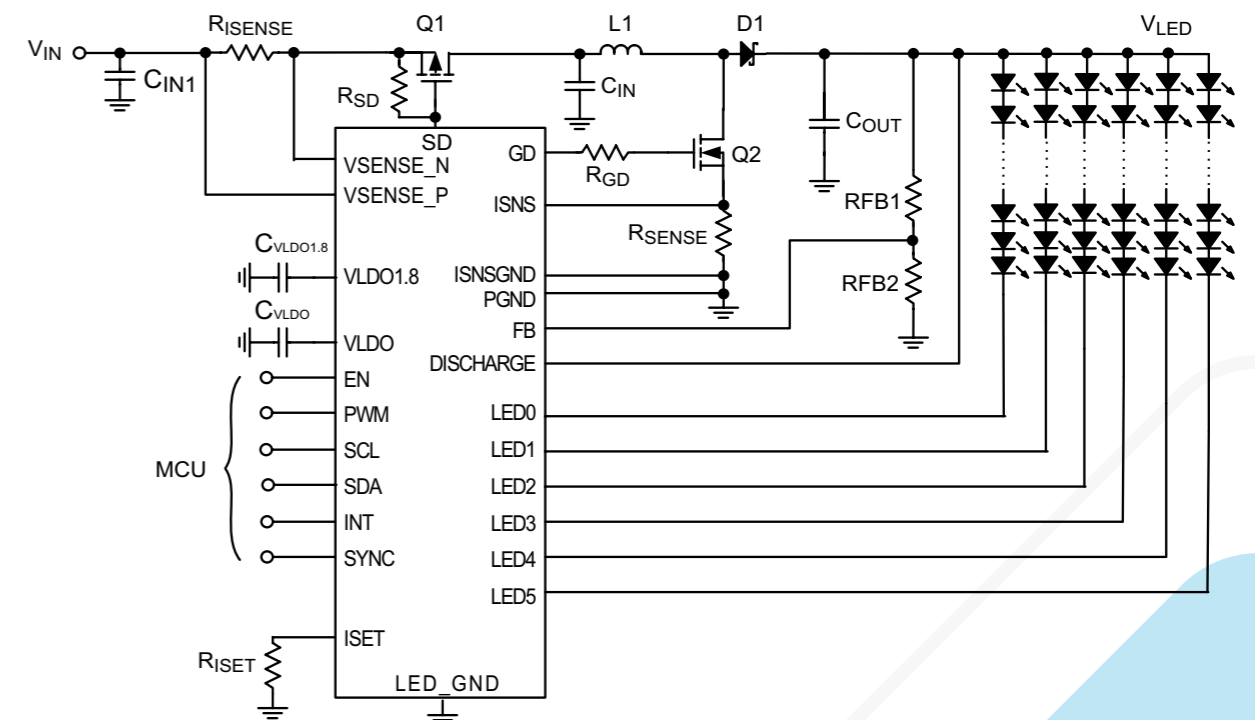

RTQ8306-QT

36-Channel Current Sink LED Driver for Local Dimming and Animated Lighting Applications

AEC-Q100 Grade 2 Certification

Key Features

- Wide Current Range: 5mA to 60mA
- Programmable Channel Current (8-Bit Resolutions)
- Low Dropout Voltage: 400mV at 60mA
- Support Dot Correlation Function
- Support HDR Mode
- Dimming Mode: PWM Mode for Scan and Non-Scan Type; Direct PWM Mode; DC Mode
- $\pm 2\%$ Accuracy Current for Wide Current Range
- LED Current Rising and Falling Slop Control
- Fault Detection for LED Open/Short
- Under-Voltage Lockout and Thermal Shutdown
- Integrated Dynamic Headroom Control (DHC)
- Support 1D/2D/3D Dimming
- 25MHz Max SPI Interface with Daisy chain
- Flexible Daisy-Chain SPI Interface

Pin Configurations

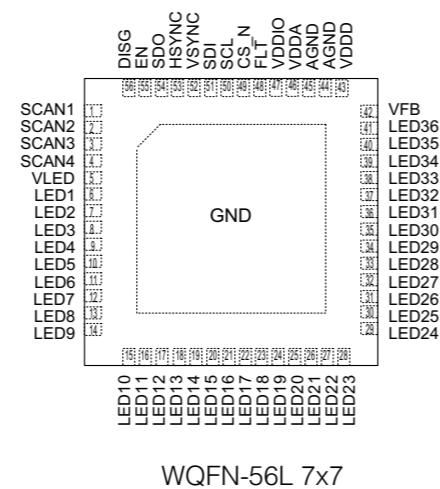

Typical Application Circuit

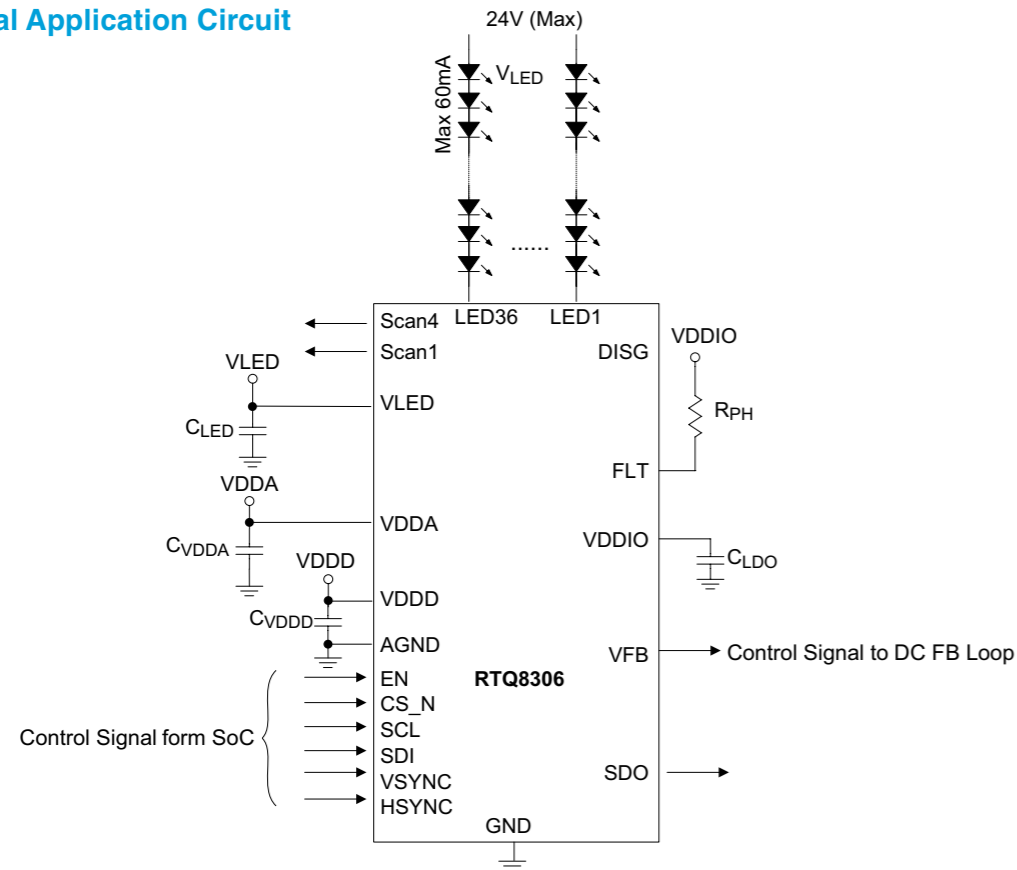

RTQ6749-QT-A2

TFT LCD Integrated Power Module for Automotive

AEC-Q100 Grade 2 Certification

Key Features

- 2.5V to 5.5V Input Supply Voltage
- $^{\circ}\text{C}$ Interface
- Power-on and Power-off Sequence Free
- PAVDD Programmable Output Voltage 5V to 7.3V
- PAVDD Output Current Capability up to 200mA
- NAVDD Programmable Output Voltage -5V to -7.3V
- NAVDD Output Current Capability up to 200mA
- VGH Programmable Output Voltage 7V to 30V
- VGH Output Current Capability up to 60mA
- VGH Output Voltage Temperature Compensation
- VGL Programmable Output Voltage -6V to -18V
- VGL Output Current Capability up to 60mA
- VCOM 8bits Programmable Output Voltage
- Outputs Power-off Discharge Function
- Programmable Voltage Detector
- Built in UVLO, UVP, OVP, SCP and OTP Protection

Typical Application Circuit

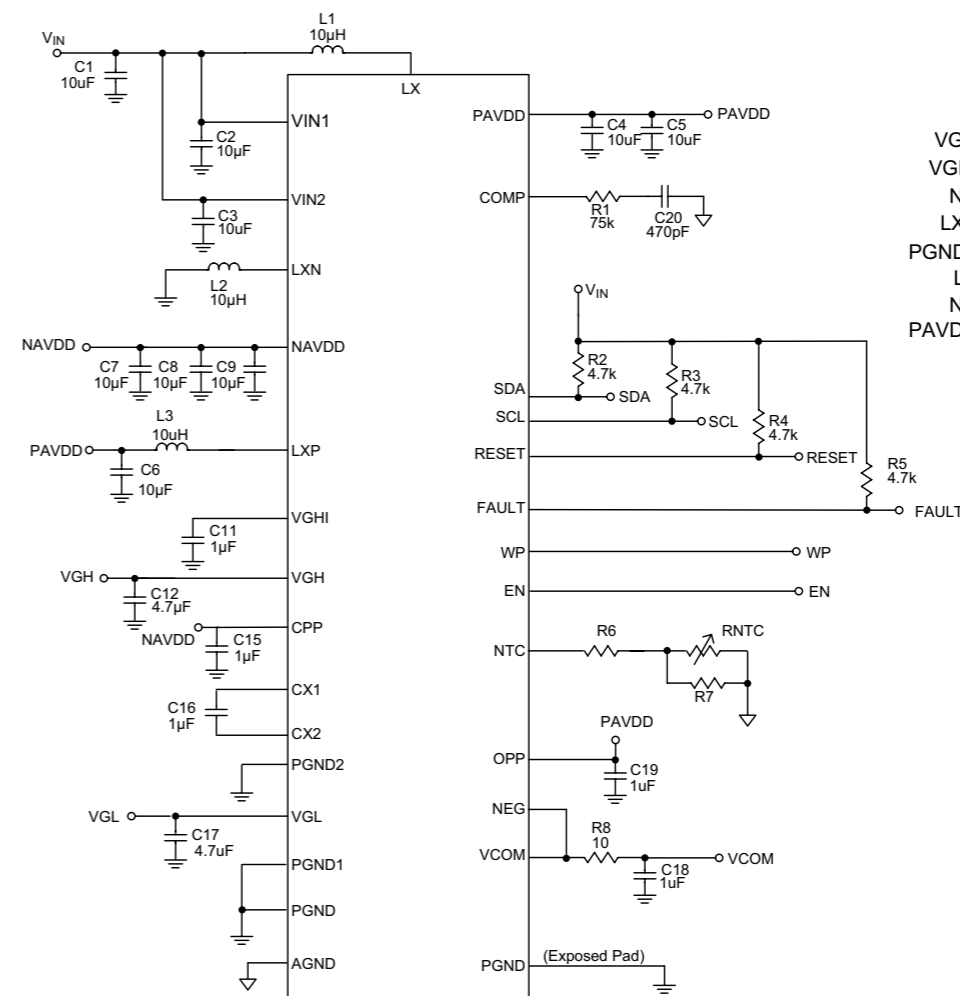

Pin Configurations

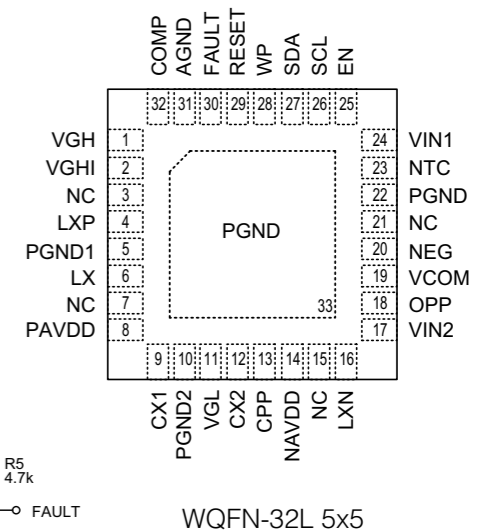

RTQ2079-QA

System Optimization FuSa PMIC for Extremely High Image Quality Automotive Camera Sensor/Module

AEC-Q100 Grade 1 Certification

Key Features

- Functional Safety-Capable
- Compliance with ISO26262 ASIL-B
- Power on BIST for OV/UV Monitor, I²C CRC and Efuse CRC Protection
- 3 Step-Down Converters (HVBuck1, LVBuck2 and LVBuck3)
 - Peak-Current Mode PWM Operation and PSM Mode to Support Sentry Mode via I²C Setting
 - Fixed Switching Frequency at 2.1MHz
 - EMI Reduction with Spread Spectrum and Phase Shift
 - HVBuck1 Vin: 4V to 28V with Load Dump Protection (36V ≤ 400ms transient), Adj. Vout and 2A Iout
 - LVBuck2 Vin: 2.7V to 5V, Adj. Vout and 1.5A Iout
 - LVBuck3 Vin: 2.7V to 5V, Adj. Vout and 1.5A Iout
 - Pins Related to LVBuck2/LVBuck3 Allowed Floating if Channel Unused
- 2 Low Dropout Regulators (LDO1 and LDO2)
 - LDO1 Vin: 2.7V to 5V, Adj. Vout and 0.3A Iout, with High PSRR : 60dB at 100kHz, 40dB at 1MHz
 - LDO2 Vin: 2.7V to 5V, Adj. Vout and 0.4A Iout
- Input and Output Functions
 - Sequence Control for External Power IC via SEQOUT
 - Power Status Indication via PGOOD
 - Error Status Indication via ERROUT
 - Two Error Signal Receivers via ERRIN1/ERRIN2
 - External Voltage Monitor via VMONIN

Typical Application Circuit

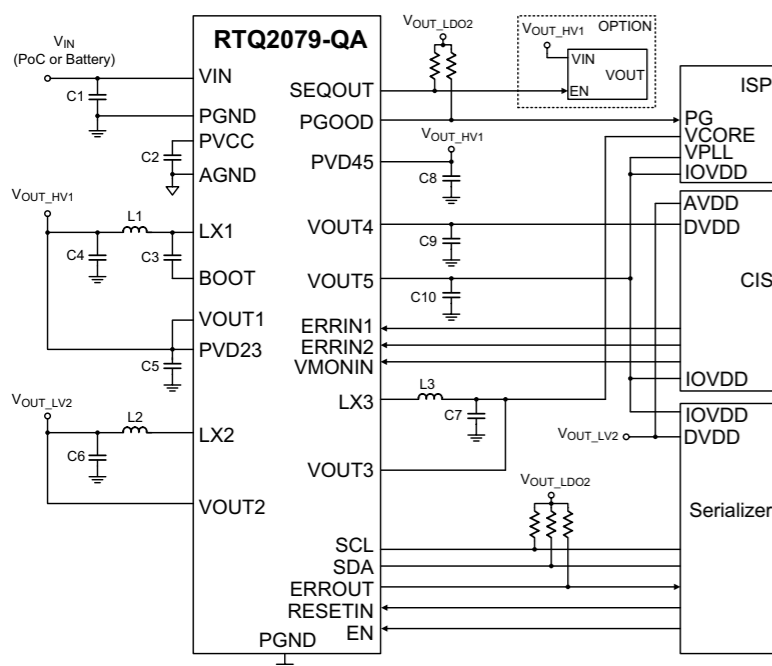

Pin Configurations

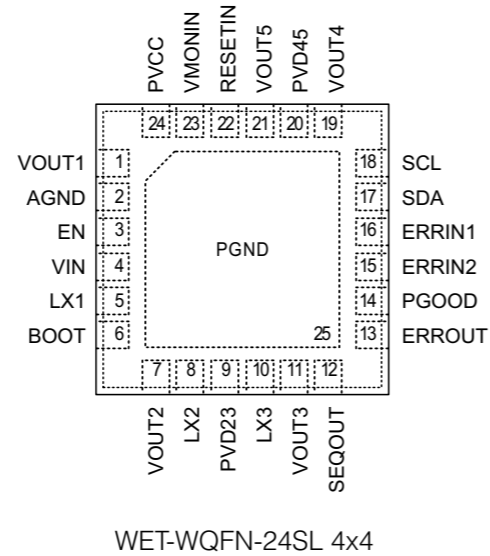

RTQ2071A/B-QA

Automotive CIS/CCM PMIC for Ultra Compact Camera and High Image Quality System

AEC-Q100 Grade 1 Certification

Key Features

- FMEA Compliant Pin Placement and Protection Mechanisms
- Three Step-Down Converters
 - Peak Current Mode PWM Operation
 - Fixed Switching Frequency at 2.1MHz
 - EMI Reduction with Spread Spectrum and Phase Shift
 - HVBuck1 Vin: 4V to 18.5V, 2A Output Current
 - LVBuck2 Vin: 2.7V to 5V, 1.5A Output Current
 - LVBuck3 Vin: 2.7V to 5V, 750mA Output Current
- Low Dropout Regulator
 - Vin: 2.7V to 5V, 300mA Output Current
 - 10 Adjustable Output Voltage Settings via RSET Pin
 - High PSRR: 60dB at 100kHz, 40dB at 1MHz
- Sequence Control for External Power IC via SEQOUT (RTQ2071A-QA)
- Power Status Indication via PG (RTQ2071B-QA)
- 10 Flexible Power Sequence Settings via SEQ Pin

Pin Configurations

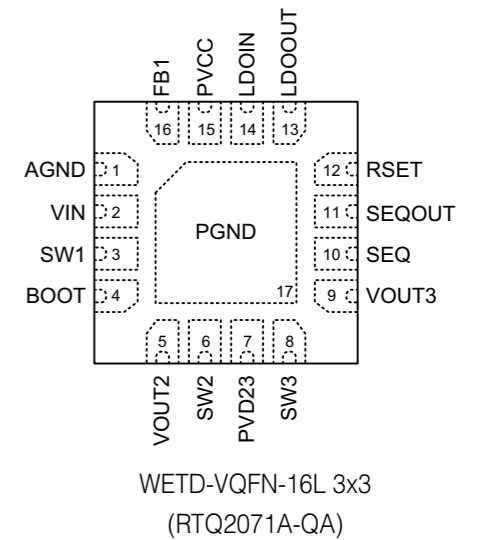

WETD-VQFN-16L 3x3 (RTQ2071A-QA)

Typical Application Circuit

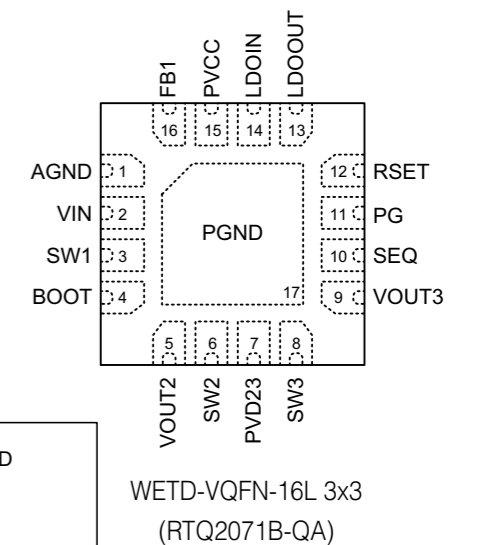
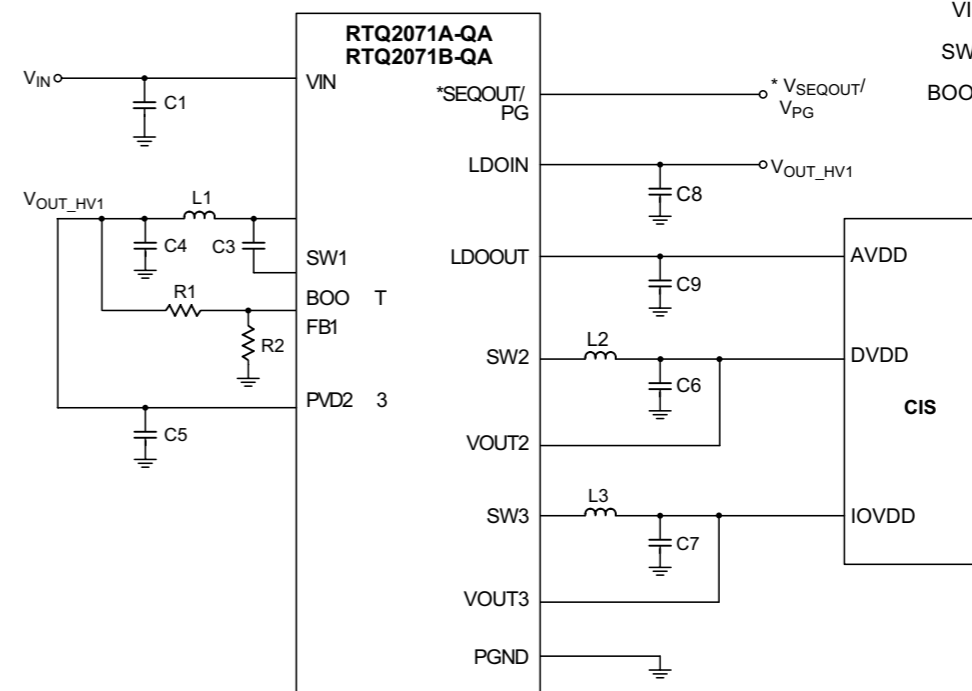

WETD-VQFN-16L 3x3 (RTQ2071B-QA)

RTQ2174/6/8/9-QA

Automotive Low EMI Buck Converter

AEC-Q100 Grade 1 Certification

Key Features

- Vin: 3V to 36V
- Fixed Vout: 3.3V, 4V and 5V via VSEL Pin
- Adj. Vout: 1V to 25V
- Iout: 4A/6A/8A/10A
- Switching Frequency
 - RT Tie to GND, $F_{sw} = 400\text{kHz}$
 - RT Tie to VCC, $F_{sw} = 2.1\text{MHz}$
 - Adj. Fsw : 200kHz to 2.3MHz via RT Resistance
- 5uA Quiescent Current at Vin=13.5V, Vout=3.3V
- 85% PFM Efficiency at 1mA, Vin=13.5V, Vout= 5V
- Short Minimum On Time and Off Time 50ns
- 99% Duty Cycle Operation in Drop Out Mode
- Optimized for Low EMI Requirements
 - Symmetric Input and Flip-Chip to Minimize Parasitic Inductance
 - Switching Random Spread Spectrum Reduces Peak Emissions
- Automatic Frequency Fold Back Smoothly

Pin Configurations

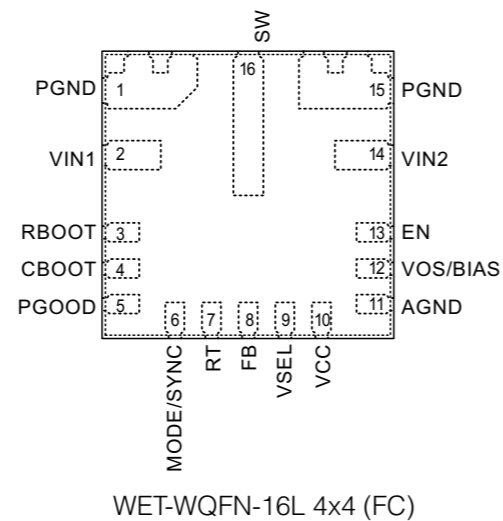

Typical Application Circuit

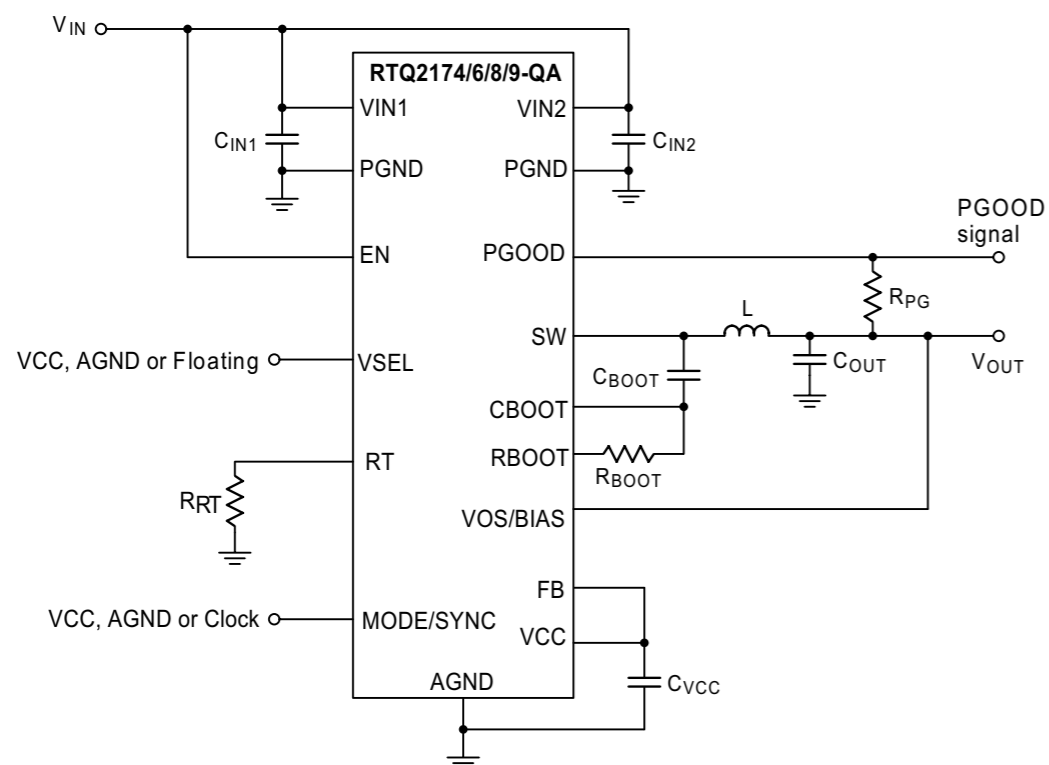

RTQ9128D4-QT

45W, Ultra-Low Noise, High-Efficiency, Digital Input 4-Channel Automotive Audio Amplifier with I²C Diagnostics

AEC-Q100 Grade 1 Certification

Key Features

- I²S and TDM input
- 4x22W, THD+N=1%, 4Ω, 14.4V
- 4x27W, THD+N=10%, 4Ω, 14.4V
- 4x45W, THD+N=10%, 2Ω, 14.4V
- 4x75W, THD+N=10%, 4Ω, 25V
- THD+N is 0.02%; SNR up to 116 dB; Ultra-Low Noise = 18 uV; Low Rds-on (80 mΩ)
- Switching Frequency up to 2.1 MHz
- Sampling Frequency from 32kHz to 192kHz
- I²C Control with 16 Address Options
- Built-in Anti-Pop Function
- Built-in Thermal Fold-back and Clip Detection

- Load Diagnostics
 - Output Open and Shorted Load
 - Output-to-Battery or Ground Shorts
 - DC and AC Coupled Load Detection
- Protection Features
 - Output Short-Circuit Protection
 - Over-Voltage and Under-Voltage
 - Output Current Limit and Protection
 - Over-Temperature
 - DC Offset
 - 40V Load Dump

Typical Application Circuit

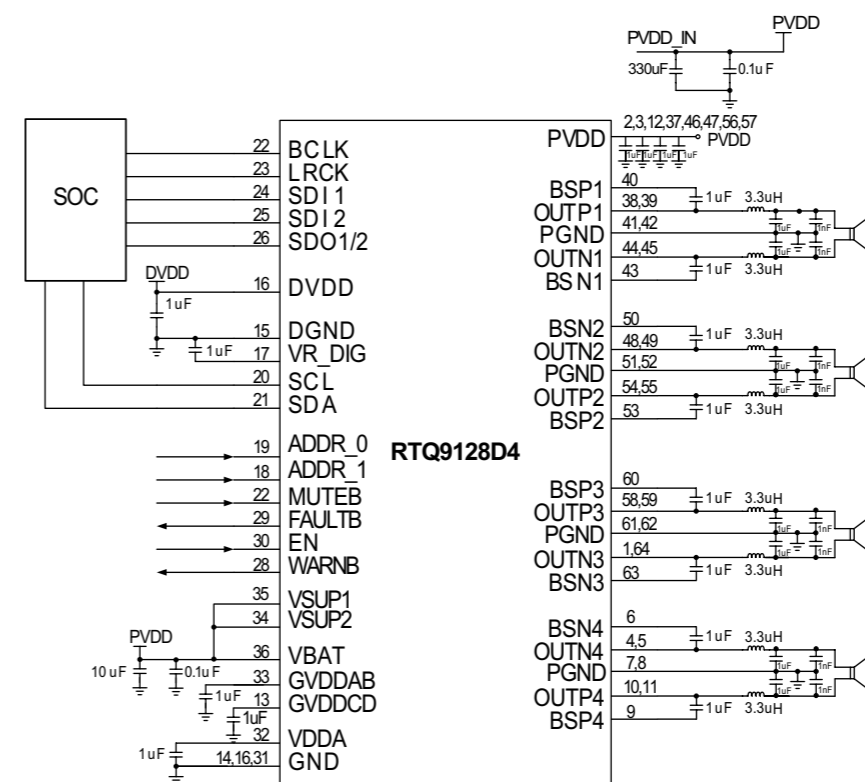

Pin Configurations

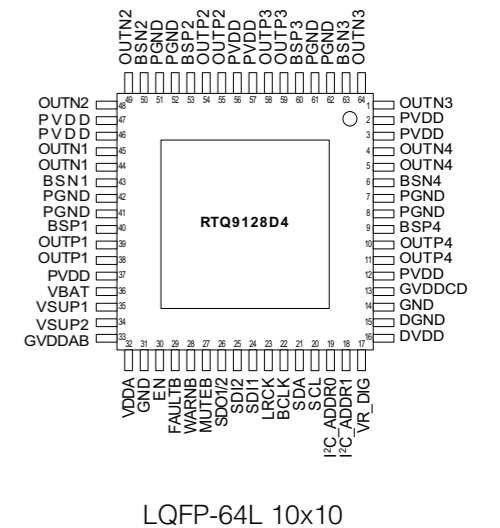

RTQ7880A-QT

USB Type-C PD and PWM Buck-Boost Controller with AnyPower™ and PD Safe® Features

AEC-Q100 Grade 2 Certification

Key Features

- Support USB Type-C Power Delivery (PD) Provider Application
- Type-C, USB PD and Communication Protocols
 - Compliant with USB PD 3.0 Specification, USB Type-C Cable and Connector Specification 1.2
 - Alternate Mode and VCONN Output
 - Support Other Proprietary Communication Protocols through Internal MCU, DP and DM Pins
- Integrated PWM Buck-Boost Controller
 - Wide Input Voltage Range: 4V to 36V
 - Peak-Current Mode PWM Operation
 - 200kHz to 600kHz Programmable Switching Frequency
 - Pulse-Skipping Mode for Light-Load Efficiency; Selectable Forced CCM Operation
- AnyPower™ for Constant Voltage Output (in 10-Bit Resolution) and Constant Current (in 9-Bit Resolution) Output Settings
- PD Safe®
 - Adjustable Converter Input Current Limit
 - Programmable VBUS OVP and VO UVP
 - Adjustable External OTP
 - VCONN1/2 Output Current Limit
- Cable Voltage Drop Compensation for VBUS
- Master and Slave I²C Interfaces
- GPIOs for MUX Control or Customized Functions
- Built-in Output Bleeders for Quick VBUS Discharge
- Built-in Charge Pump for Driving Cost-Effective N-MOSFETs
- Online Firmware Update via Slave I²C Interface
- USB PD PD3.0/PPS Certification Passed (TID 1080016)

Pin Configurations

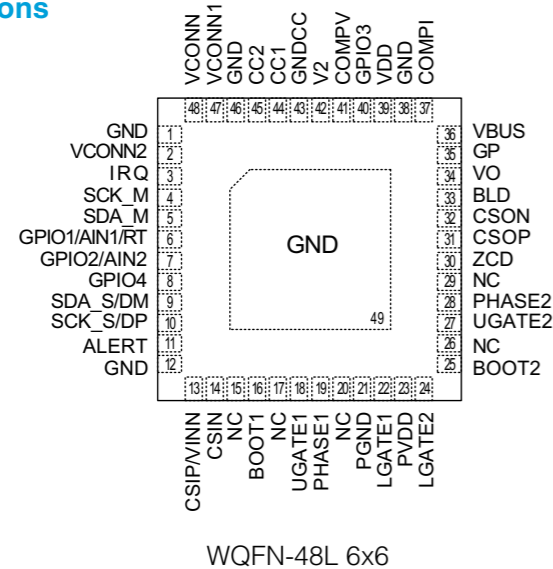

Typical Application Circuit

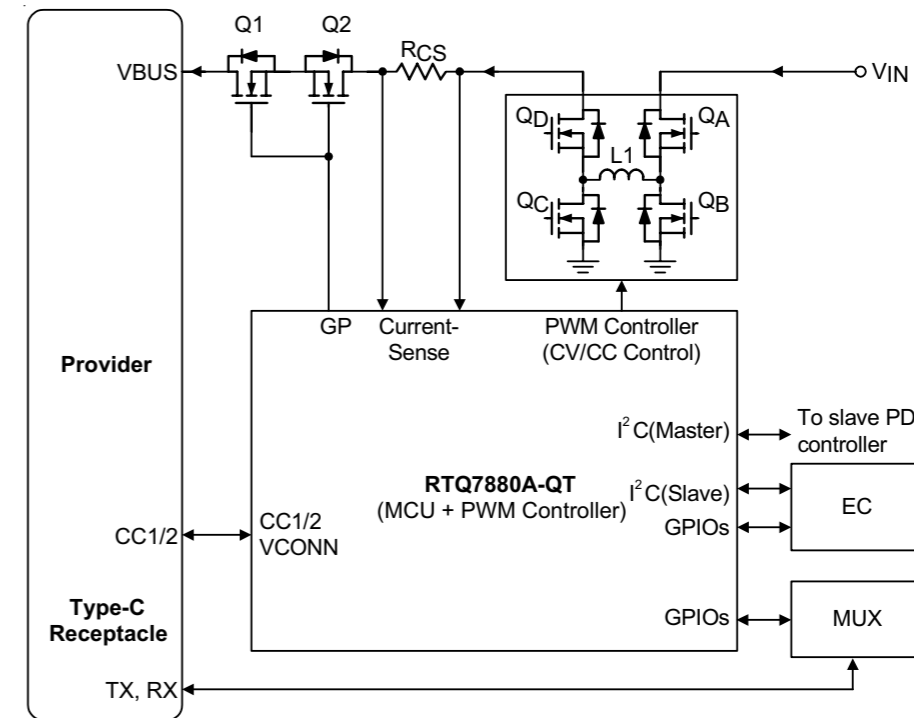

Simplified Functional Block Diagram

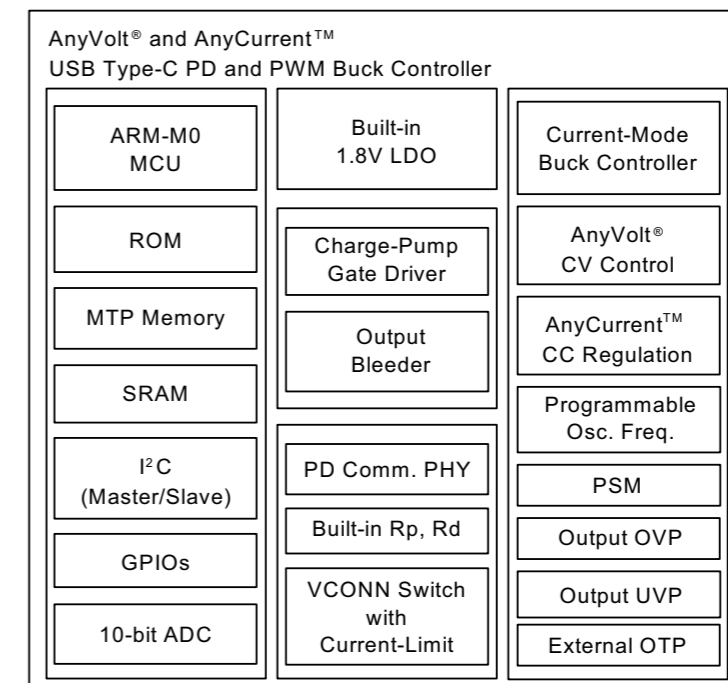

RTQ7881A-QT

USB Type-C PD and PWM Buck Controller with AnyPower™ and PD Safe® Features

AEC-Q100 Grade 2 Certification

Key Features

- Support USB Type-C Power Delivery (PD) Provider Applications
- Operating Ambient Temperature: -40°C to 105°C
- Type-C, USB PD and Communication Protocols
 - Compliant with USB PD 3.0 Specification, USB Type-C Cable and Connector Specification 1.2
 - Alternate Mode and VCONN Output
 - Support Other Proprietary Communication Protocols through Internal MCU, DP and DM Pins
- Integrated PWM Buck Controller
 - Wide Input Voltage Range: 4V to 36V
 - Peak-Current Mode PWM Operation
 - Programmable PWM Switching Frequency (200kHz to 600kHz)
 - Pulse-Skipping Mode for Light-Load Efficiency; Selectable Forced CCM Operation
- AnyPower™ for Constant Voltage Output (11.7 or 23.4mV/step, typ.) and Constant Current (in 9-Bit Resolution) Output Settings
- PD Safe®
 - Adjustable Converter Input Current Limit
 - Programmable VBUS OVP and VO UVP
 - Adjustable External OTP
 - VCONN1/2 Output Current Limit
- Cable Voltage Drop Compensation for VBUS
- Master and Slave I²C Interfaces
- GPIOs for MUX Control or Customized Functions
- Built-in Output Bleeders for Quick VBUS Discharge
- Built-in Charge Pump for Driving Cost-Effective N-MOSFETs
- Online Firmware Update via Slave I²C Interface

Pin Configurations

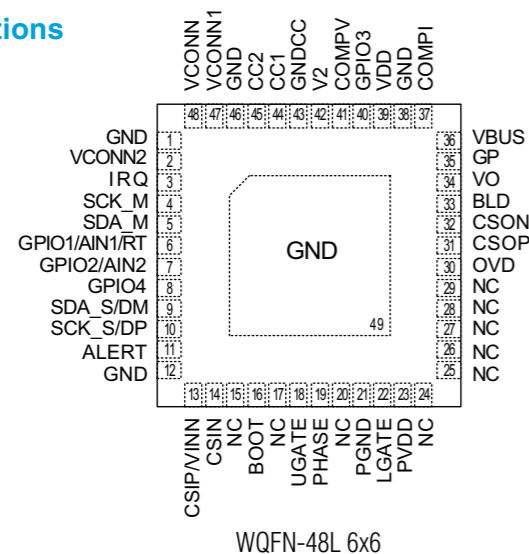

Typical Application Circuit

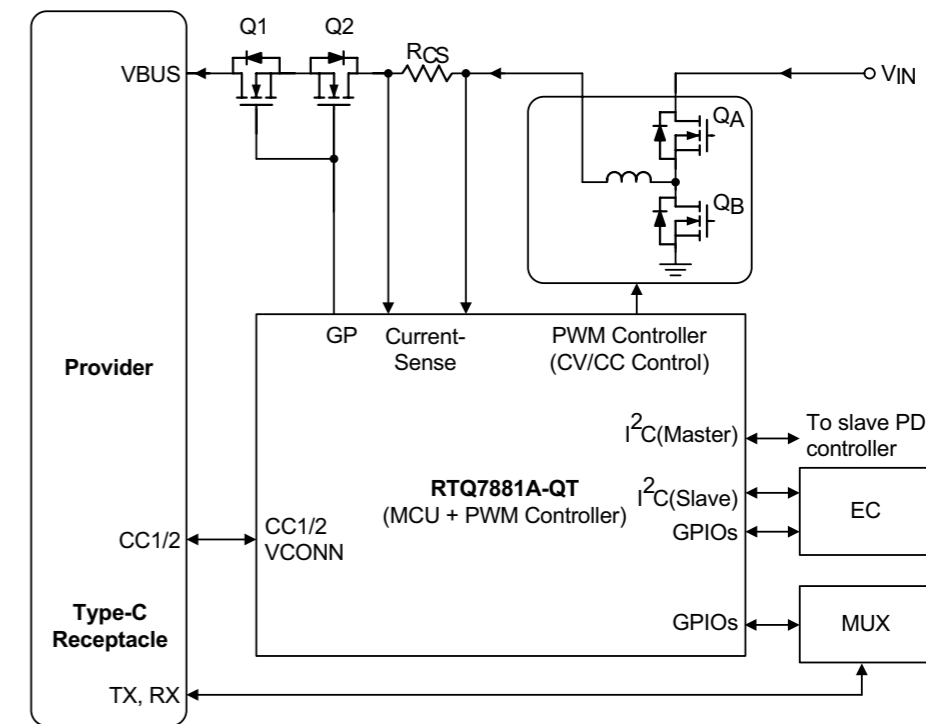

Simplified Functional Block Diagram

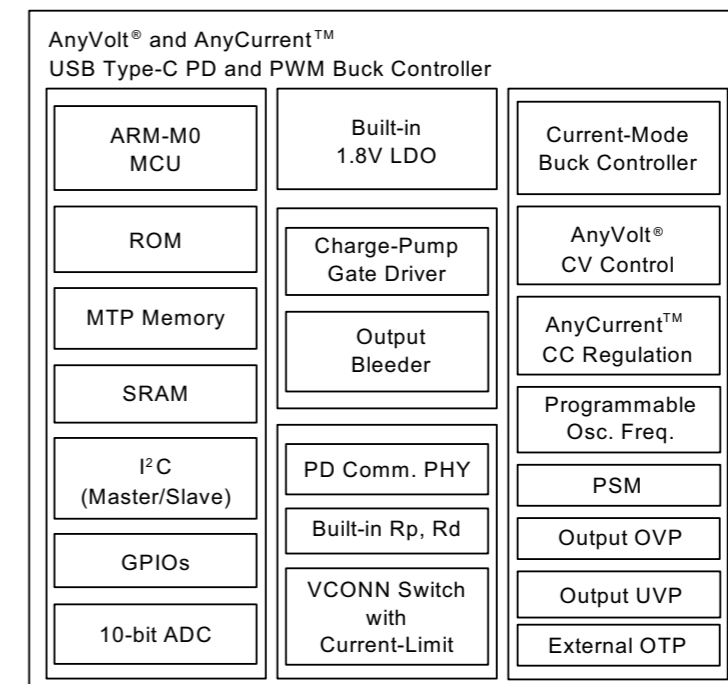

RTQ7882-QT

USB Type-C PD and PWM Buck-Boost Controller with AnyPower™ and PD Safe® Features

AEC-Q100 Grade 2 Certification

Key Features

- Support USB Type-C Power Delivery (PD) Provider
- Operating Ambient Temperature: -40°C to 105°C
- Type-C, USB PD and Communication Protocols
 - Compliant with USB PD 3.0 Specification, USB Type-C Cable and Connector Specification 1.2
 - VCONN Output 100mW
 - 32kB ROM + 32kB MTP
 - Support Other Proprietary Communication Protocols through Internal MCU, DP and DM Pins
- Integrated PWM Buck-Boost Controller
 - Wide Input Voltage Range: 4.5V to 27V
 - Wide Output Voltage Range: 3.3V to 21V
 - Peak-Current Mode PWM Operation
 - Internal Compensation for CV, CC
 - Programmable PWM Switching Frequency (200kHz to 600kHz)
 - Pulse-Skipping Mode for Light-Load Efficiency; Selectable Forced CCM Operation
- AnyPower™ for Constant Voltage Output and Constant Current Output
- PD Safe®
 - Adjustable Converter Input Current Limit
 - High Accuracy Input Over-Current Protection
 - Fast Response VIN OVP/UVF Detection
 - Programmable VBUS OVP and VO UVP
 - Fast Response OVP for CC1/2 and D+/D-
 - Adjustable External OTP/Internal OTP
 - CC1/2 Output Current Limit
 - CC1/2, D+/D- 25V Tolerant
 - Cable Voltage Drop Compensation for VBUS
 - EN Control for Power Saving
- Switching Frequency Synchronization for Better EMI Performance
- Adjustable Gate Drive Current for Better EMI Performance
- Firmware-based Functions
 - VIN De-Rating and Power Sharing
- Master and Slave I²C Interfaces, LED Drivers, GPIOs
- Built-in Output Bleeders for Quick VBUS Discharge
- Built-in Charge Pump for Driving Cost-Effective N-MOSFETs
- Built-in Internal LDO
- Online Firmware Update via Slave I²C Interface or CC1/2 Interface

Typical Application Circuit

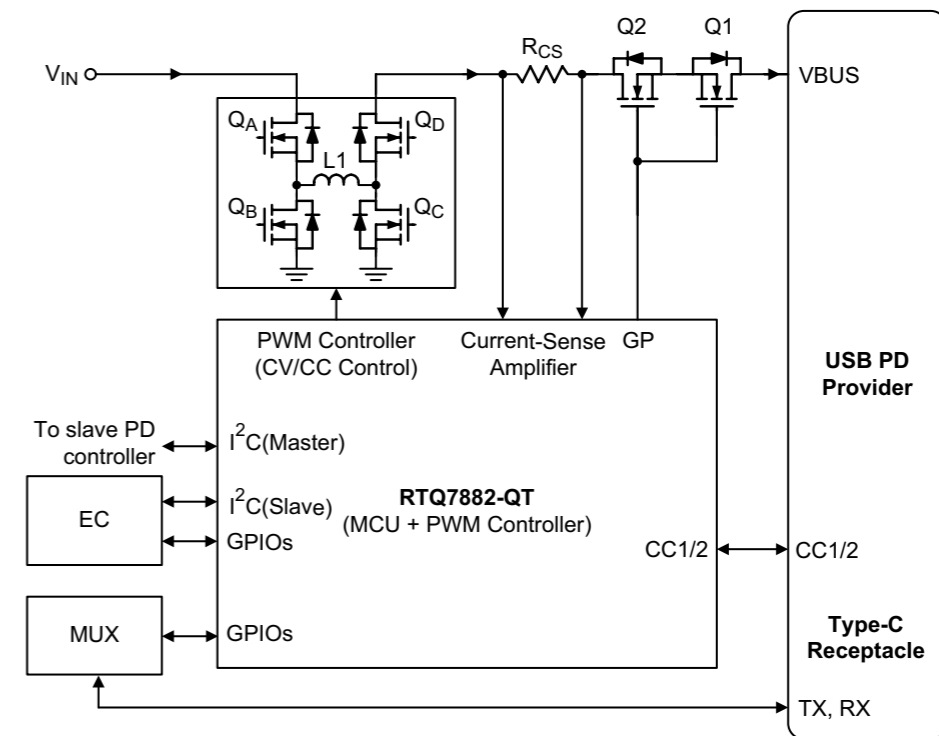

Pin Configurations

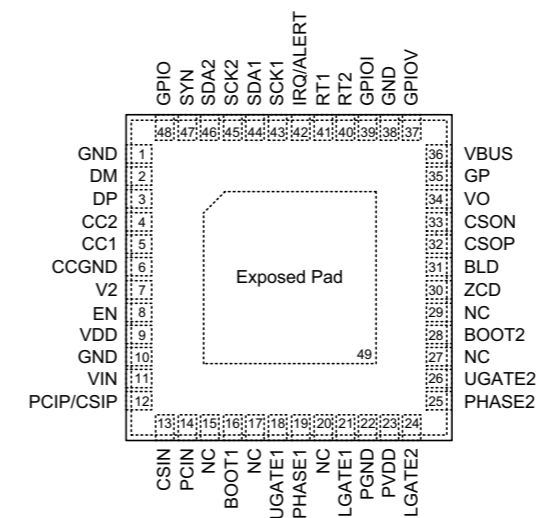

WET-WQFN-48L 6x6

RICHTEK

your power partner.

Taiwan Headquarters

Add: 14F, No.8, Tai Yuen 1st Street, Chupei City, Hsinchu, Taiwan 30288
30288 新竹縣竹北市台元一街 8 號 14 樓
Tel: 886-3-5526789

China Beijing Office

Add: Room 2303, Tower 2-C, Wangjing SOHO, Fu Tong East Street No.1, Chaoyang District, Beijing City, P.R.C. 100102
100102 北京市朝阳区阜通东大街 1 号院望京 SOHO T2-C 2303 室
Tel: 86-10-57077385
E-Mail: sales_cn@richtek.com

Shenzhen Office

Add: 10F CR Land Building Tower E, No.18, Dachong 1 Road, Nanshan District, Shenzhen, P.R.C. 518052
518052 深圳市南山区大冲一路 18 号华润置地大厦 E 座 10 楼
Tel: 86-755-88353955
E-Mail: sales_cn@richtek.com

Korea Gyeonggi-do Office

Add: 3F, TWOSUNWORLD BUILDING, 221, Pangyoyeok-ro, Bundang-gu, Seongnam-si, Gyeonggi-do, Korea 13494
경기도 성남시 분당구 판교역로 221 (삼평동 672) 투싼월드빌딩 3 층
Tel: 82-31-718-5703
E-Mail: sales_kr@richtek.com

US San Jose Office

Add: 2840 Junction Avenue, Suite 101, San Jose, CA 95134 USA
Tel: 1-408-2406668
E-Mail: sales_us@richtek.com

Taiwan Taipei Office

Add: 5F, No.95, Minquan Rd., Xindian Dist., New Taipei City, Taiwan 23141
23141 新北市新店區民權路 95 號 5F
Tel: 886-2-86672399
E-Mail: sales_tw@richtek.com

China Shanghai Office

Add: Room 409, 1077 zuchongzhi Road, Zhang Jiang Hi-Tech Park, Pudong new area, Shanghai, P.R.C. 201203
201203 上海浦东新区张江高科祖冲之路 1077 号 1 号楼 409 室
Tel: 86-21-50277077
E-Mail: sales_cn@richtek.com

Suzhou Office

Add: 4F, No. 188, SuHongXi Road, SIP (Suzhou Industrial Park), Suzhou, Jiangsu, P.R.C. 215021
215021 苏州工业园区苏虹西路 188 号 4F
Tel: 86-512-68784656
E-Mail: sales_cn@richtek.com

Japan Tokyo Office

Add: SEA FORT SQUARE/CENTER BUILDING, 15F, 2-3-12 Higashi-Shinagawa, Shinagawa-ku, Tokyo 140-0002, Japan
〒 140-0002 東京都品川区東品川二丁目 3 番 12 号 シーフォートスクエア / センタービルディング 15 階
Tel: 81-3-54797241
E-Mail: sales_jp@richtek.com

Europe The Netherlands, Eindhoven Office

Add: High Tech Campus 9, 5656AE, Eindhoven, The Netherlands
Tel: +31-40-8515520
E-Mail: sales_eu@richtek.com

Scan to download the automotive product selection guide via the Richtek website.

